

LARGEST CIRCULATION OF ANY MECHANICAL PUBLICATION IN THE WORLD

\$1. per year

JANUARY

10 Cents

# POPULAR MECHANICS

WRITTEN SO YOU CAN UNDERSTAND IT

## Duluth Aerial Bridge Ferry

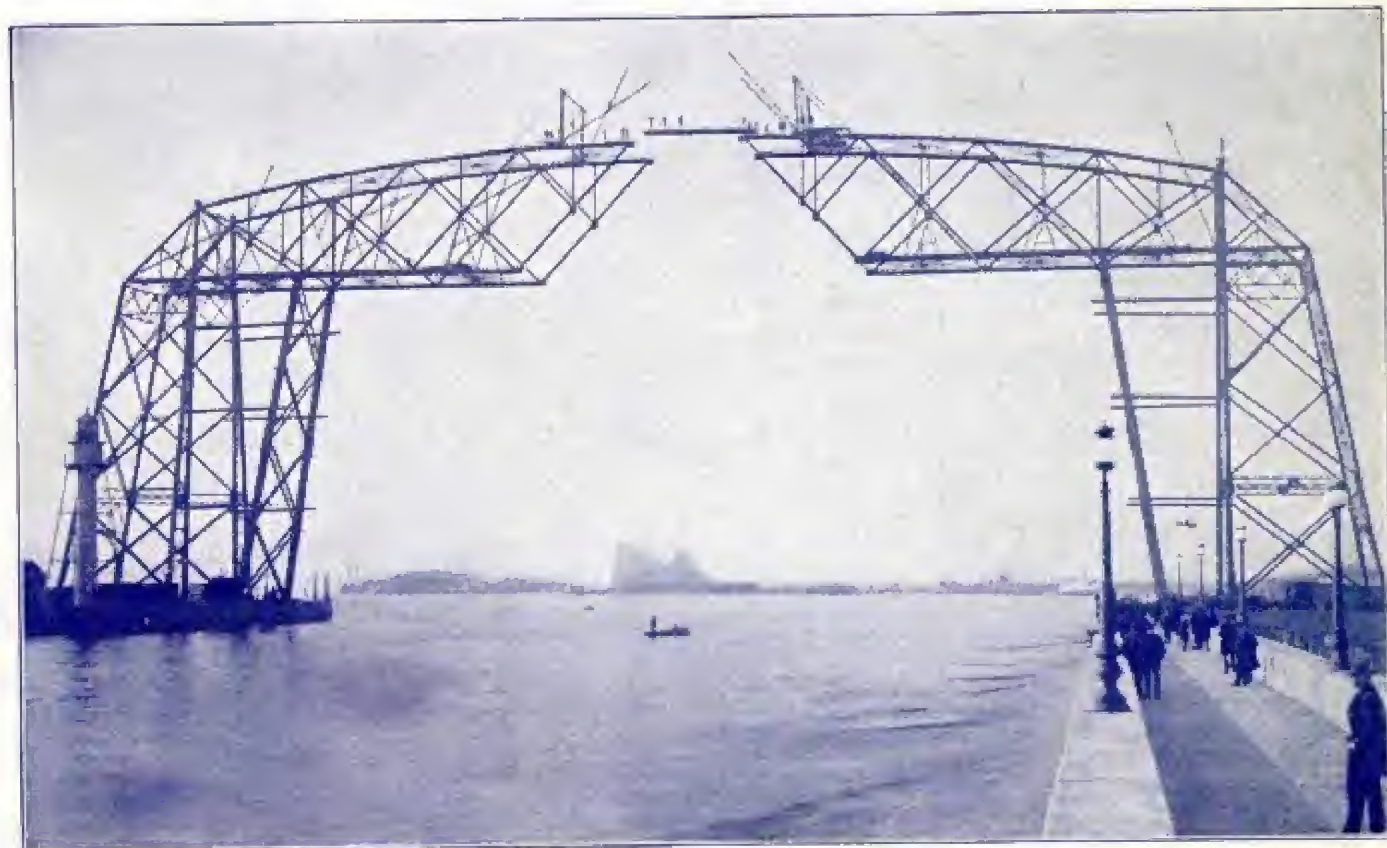

**Placing the Steel Girder Which First Connects the Mighty Span--The Workmen are 250 Feet above the Water--Only Structure of its Kind on this Continent--See Page 106.**

**UNDER-WATER ARMOR FOR BATTLESHIPS--See Pages 115-118**



## The "OTTO" Still in the Lead

It is not surprising that the "OTTO" was awarded the Gold Medal at St. Louis. In fact it has never failed to take first prize wherever exhibited. Below is a list of the "OTTO" triumphs in America:

Philadelphia Centennial, 1876  
 New York, 1880  
 Cincinnati, 1880  
 New York, 1881  
 Louisville, 1883  
 San Francisco, 1884  
 New York, 1885  
 New Orleans, 1885  
 Buffalo (Pan-American), 1901

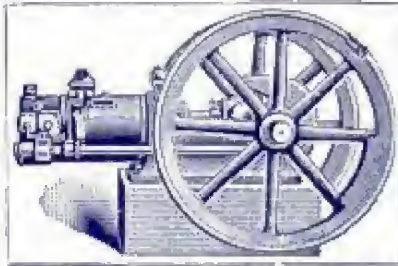

Chicago World's Fair, 1893  
 Atlanta, 1895  
 New York, 1896  
 Nashville, 1896  
 New York, 1897  
 Omaha, 1898  
 Omaha, 1899  
 Philadelphia, 1899  
 St. Louis (Louisiana Purchase Exposition) 1904

No engine could be uniformly successful without deserving it.

**THE OTTO GAS ENGINE WORKS, Philadelphia, Pa.**

CHICAGO: 360 Dearborn Street

MINNEAPOLIS: 318 3d Street

OMAHA: 1108 Farnam Street

## THE "RELIABLE ROUND TRACK DOOR HANGER"

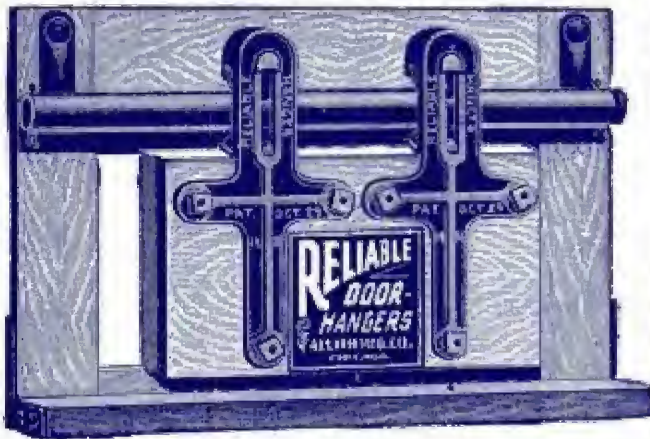

You know how the old-fashioned Door-Hanger sticks  
**Ours** Will Not Bind  
**Ours** Cannot be Derailed

### Let Us Tell You About It

WRITE FOR CATALOG AND PRICES

**ALLITH MANUFACTURING CO.**

120 South Green Street, Chicago



A  
**MILLSTONE  
 ABOUT  
 THE  
 NECK**

Lack of special training is the "millstone about the neck" of most men and women in poor paying positions. It holds them back while others go ahead. It handicaps them everywhere. The International Correspondence Schools' system of training by mail will enable you to throw off the burden. By this means you can rise to one of the higher positions in your present trade or profession. You can qualify for a more congenial occupation and better salary. We have helped thousands of others. We can help you. Decide today to better your condition.

We teach Engineering in all its branches; Architecture; Mechanical Drafting; Ad Writing; Show-Card Writing; Window Dressing; Illustrating; Ornamental Designing; Book-keeping; Stenography; Etc.

Write today, stating which Course interests you.

**International Correspondence Schools**  
 Box 872, Scranton, Pa.

## MOTOR CASTINGS

3 1/2 H. P. water-cooled single cylinder : : \$ 25.00	2 H. P. air-cooled single cylinder : : : : \$11.00
7 H. P. " " double cylinder opposed 40.00	3 H. P. " " " " : : : : 16.00
25 H. P. " " four cylinder upright : 100.00	5 H. P. " " double cylinder upright : 35.00
1 1/2 H. P. air-cooled single cylinder : : : 9.00	7 H. P. " " " " " " : : : 40.00
7 H. P. air-cooled double cylinder opposed : : : \$40.00	

Prompt delivery. Send 5c. for our 90-page catalogue

**THE AUTOMOBILE SUPPLY CO.**

1339 Michigan Blvd.

Chicago, Ill., U. S. A.



# POPULAR MECHANICS

"Written So You Can Understand It."

A Monthly Magazine.  
PUB. BY POPULAR MECHANICS CO.  
Eastern Office:  
116 Nassau Street, New York.

JOURNAL BUILDING  
**CHICAGO**

SUBSCRIPTION \$1.00 PER YEAR  
Foreign Countries \$1.50  
Entered at the Chicago Postoffice as  
Mail Matter of the Second Class.

VOL. VII. CONTENTS FOR JANUARY, 1905 NO. 1

<b>LOCOMOTIVE WITHOUT FIRE OR WATER</b> .....101	<b>CONNING TOWER—BRAIN OF THE BATTLESHIP</b> .....133
<b>POWERFUL HOISTING ENGINE USED IN A DEEP MINE</b> .....103	The "Autopyrophon," a New Automatic Fire Alarm.....133
<b>MODEL OF VERY LARGE LOCOMOTIVE</b> .....104	Boring Holes in Log Water Mains.....134
The Largest Troopship in the World.....104	Multiplying Water Power.....134
<b>TRAGIC FATE ENDS "FOOLKILLER NO III"</b> .....105	<b>MECHANICS FOR YOUNG AMERICA—</b>
<b>DULUTH AERIAL FERRY</b> .....106	How to Make a Miniature Windmill.....152
Measured Service Meters for Telephone Patrons.....107	How to Build an Ice Boat.....153
<b>Unsinkable Life-Boats</b> .....107	Telegram from New York to Chicago Travels 24,000 Miles.....154
<b>Constructing a Tall Steel Smokestack</b> .....108	Ornamental Metal Guards for Open Fireplaces and How to Make Them.....155
<b>Steel Tires and Spring Wheels for Automobiles</b> .....108	<b>HISTORY OF IRON WORKING</b> .....158
<b>PORTABLE WATER-DISTILLING PLANTS</b> .....109	<b>SHOP NOTES</b>
<b>WONDERFUL INSTRUMENT WHICH PREDICTS TIDES</b> .....111	Proper Method of Using Sandpaper.....135
<b>ORE UNLOADED AUTOMATICALLY</b> .....112	Some Good Paints for Stacks and Boiler Fronts.....135
Belgian Government Builds Turbine Steamer for Mail Service.....114	<b>A Simple Fire Extinguisher</b> .....135
<b>UNDER-WATER ARMOR FOR BATTLESHIPS</b> .....115	<b>A Handy Concrete Formula</b> .....135
Big Railway Car-Building Plant for Montreal.....118	<b>The Best Method of Fastening Guy Logs</b> .....135
Demand for Expert Mining Engineers.....118	Use of Muriatic Acid in Coppering Steel or Iron.....136
<b>Electric Railway Power from Gas Engines</b> .....118	<b>Device for Cutting Wood Gutters</b> .....136
<b>Automatic Danger Signal for Broken Bridges</b> .....119	<b>How to Canvas a Board Ceiling</b> .....136
<b>Heat from Fireplace Without Light</b> .....119	<b>Polish for Hot Metal</b> .....136
<b>Combined Muffler and Whistle for Gas Engines</b> .....119	<b>Tool Box for Millers</b> .....136
<b>Electric Mall Wagons in Paris</b> .....119	<b>Economical Method of Getting Up Steam in Extra Boiler</b> .....137
<b>A NORTH SEA TRAWLER AND A JAPANESE TORPEDO BOAT</b> .....120	<b>How to Sling a Barrel</b> .....137
How to Produce Colored Photographs of Fern Leaves.....120	<b>First Thing to Do in Case of Accident</b> .....137
<b>How to Mend Cracked Negatives</b> .....120	<b>Cleaning Clogged Pipes</b> .....138
<b>"MITCHELLITE," THE NEW SMOKELESS EXPLOSIVE</b> .....121	<b>Repair for a Cut Journal</b> .....138
Novel Double Deck Street Car.....122	<b>Setting Poles in Soft Ground</b> .....138
<b>Selling Submarines to Belligerents</b> .....122	<b>Some Pipe Problems Solved</b> .....139
<b>WHERE MILLIONS OF DOLLARS ARE MADE</b> .....123	<b>Cement for Closing Leaks in Iron Pipe</b> .....139
<b>Heat Without Fuel</b> .....124	<b>Keys for Shafts</b> .....140
<b>Watch Inspection for Big Railway Systems</b> .....124	<b>A Novel Way of Bushing a Flywheel</b> .....142
<b>PRIVATE ELECTRIC FIRE APPARATUS</b> .....125	<b>Laying a Copper Roof</b> .....143
<b>Floating Motor Houseboat on the Mississippi</b> .....126	<b>Push-Guying Telephone Poles</b> .....143
<b>Automatic Sculptors</b> .....126	<b>To Letter on Canvas</b> .....143
<b>Asphalt Paving Heats Horses' Shoes</b> .....127	<b>Brazing Cast Iron</b> .....144
<b>TRANSPORTING THE WOUNDED ON GERMAN WAR VESSELS</b> .....127	<b>Automatic Electric Circular Saw Mill</b> .....144
<b>Index for 1904</b> .....127	<b>Measuring Waste Heat from Gas Engines</b> .....145
<b>New Fire Boat for Manchester Ship Canal</b> .....128	<b>Recipes for Polishing Brass</b> .....145
<b>The Hydrovolve, a New Form of Water Wheel</b> .....128	<b>Simple Method of Winding Coil Springs</b> .....145
<b>First Gasoline Road Roller in England</b> .....128	<b>A Table of Principal Alloys</b> .....146
<b>Motor Boats for Ocean Races</b> .....129	<b>Why Flywheels Burst</b> .....146
<b>HOW MIRRORS ARE MADE</b> .....129	<b>Piston Rings</b> .....147
<b>Gain in Quicksilver Production in 1903</b> .....130	<b>To Prevent Water from Freezing</b> .....147
<b>Low Tide in the Harbor of Panama</b> .....131	<b>Fishing Tools for Use in Deep Wells</b> .....147
<b>Naphthaline as a Substitute for Gasoline</b> .....131	<b>Power Required for Air Lift</b> .....148
<b>CONSTRUCTION OF A GAS TURBINE</b> .....132	<b>Good Arrangement of Boiler Feed and Blow-Off</b> .....148
	<b>To Make Blueprints Brown</b> .....149
	<b>How to Build a Stock Cart</b> .....149
	<b>Device for Truing Collector Rings</b> .....149
	<b>Tables Showing the Percentage of Cotton, by Weight, on Magnet Wires of Various Sizes</b> .....150
	<b>To Blacken Brass</b> .....151
	<b>Wire Solder</b> .....151



# RUBBER AS AN INVESTMENT

is sure to yield large returns. The owner of a bearing rubber orchard recently refused \$1,200.00 per acre for it. Had you been in his place you would have done the same, for it is worth more.

## WE ARE PLANTING RUBBER

which in a few years will be worth the price above quoted, but which you can now purchase for less than one-fifth that amount, per acre. Is not such an investment worth while?

Meanwhile your money is not idle, but earning a larger rate of interest than your savings account. We have just paid

## DIVIDENDS OF 8 %

to our investors, earned from side crops. Besides rubber, we are planting and raising sugar-cane, cassava, oranges, hogs and cattle.

Our dividends will become larger annually until rubber comes into bearing, when they will amount to 50 per cent or over.

To plant the remainder of our 5,000 acres we are offering Plantation Certificates on terms within reach of all. The proposition is absolutely safe. It is being managed by men of experience and ability. Remember, we don't want your money until you are satisfied that our proposition is genuine. Don't fail to **WRITE NOW** for our illustrated literature. It costs you nothing.

**PAN-AMERICAN PLANTERS CO., 153 LaSalle St., Chicago**

If You Like "Pop." Why Not Send it to a Friend

## FOR ONE YEAR?

Cannot fail to please any man and  
will please him for twelve months

Fill in address and mail  
with One Dollar at our risk.

POPULAR MECHANICS, Journal Building, Chicago

Send your Magazine one year, commencing with the month of \_\_\_\_\_

NAME \_\_\_\_\_

STREET \_\_\_\_\_

CITY \_\_\_\_\_ STATE \_\_\_\_\_

and notify party named above that the subscription has been paid for, and is sent with the compli-

ments of \_\_\_\_\_



# Continue Your Education at Home

BY A SHORT STUDY OF OUR SELF-EDUCATIONAL BOOKS

These perfectly compiled and arranged volumes are full of mental stimulus and practical helps for the young man desiring to become expert in his particular profession. They are written by practical men, making them scientifically accurate in statement and yet devoid of all technicalities throughout. Even a child can understand them.



**Modern Carpentry**, by Fred T. Hodgson, 256 pages, 230 illustrations, cloth binding. Price \$1.00.

**Practical Uses of the Steel Square**, by Fred T. Hodgson, two volumes, 560 pages, 500 illustrations, cloth binding. Price \$2.00.

**Modern Estimator and Contractors' Guide**, by Fred T. Hodgson, 250 pages, fully illustrated, cloth binding. Price \$1.50.

**Hodgson's New Hardwood Finishing**, by Fred T. Hodgson, 320 pages, fully illustrated, cloth binding. Price \$1.00.

**Common Sense Stair Building and Handrailing**, by Fred T. Hodgson, 256 pages, 230 illustrations, cloth binding. Price \$1.00.

**Builders' Architectural Drawing, Self-Taught**, by Fred T. Hodgson, fully illustrated, 14 double plates, cloth binding. Price \$2.00.

**Swingle's Handbook for Steam Engineers and Electricians**, by C. F. Swingle, M. E., 600 pages, hundreds of fine engravings, bound in full leather. Price \$2.50.

**Modern Wiring, Diagrams and Descriptions**, by H. C. Horstman and V. H. Tousley, 160 pages, 200 illustrations, leather binding. Price \$1.50.

**Electricity Made Simple**, by Clark C. Haskins, 220

pages, 100 illustrations, cloth binding. Price \$1.00.

**Dynamo Tending for Engineers**, by H. C. Horstman and V. H. Tousley, 250 pages, 100 illustrations, cloth binding. Price \$1.50.

**Easy Electrical Experiments**, by L. P. Dickinson, 250 pages, 200 illustrations, cloth binding. Price \$1.00.

**Practical Telephone Handbook**, by T. S. Baldwin, 200 pages, fully illustrated. Price \$1.00.

**Telegraphy Self-Taught**, by Theodore A. Edison, M. A., instructor at American School of Telegraphy, fully illustrated, cloth binding. Price \$1.00.

**Farm Engines and How to Run Them**, by James H. Stephenson and other experts, 220 pages, 75 illustrations. Price \$1.00.

**Modern Air Brake Practice**, by Frank H. Dukesmith, 303 pages, fully illustrated. Price \$1.50.

**Modern Blacksmithing, Horseshoeing and Wagon Making**, by J. G. Holmstrom, 200 pages, fully illustrated. Price \$1.00.

**Book-Keeping Self-Taught**, by P. C. Goodwin, cloth binding. Price \$1.00.

**Picture Making**, by T. S. Baldwin, fully illustrated, cloth binding. Price \$1.25.

**LEARN LAW AT HOME** By the aid of our HOME LAW SCHOOL SERIES, which requires only a few hours' study occasionally; will prepare for the Bar in any State: Theory and Practice combined. Approved by Bench, Bar and thousands of successful students. Write for booklet of testimonials sent FREE. SPECIAL OFFER NOW IN FORCE. Your money refunded without question, if within five days after the receipt of any volumes you are dissatisfied with them. ADDRESS

## FREDERICK J. DRAKE & COMPANY

Publishers of Self-Educational  
Books for Home Study.

Nos. 211-213 East Madison Street, Chicago

Please mention Popular Mechanics when ordering Catalogues Free.







# Real Estate Mortgages at 6%

**SAVINGS DEPOSITS AT 3%**

**GOVERNMENT BONDS AT 2%**

ARE SAFE, BUT YOUR INCOME FROM THEM WILL NOT ADD MATERIALLY TO YOUR WEALTH

## Your Investment SHOULD BE PROFITABLE

**A Mining Investment, if a successful one, yields larger Profits on the money invested than any other**

\*\*\*\*\*  
THE Stock of THE NORTH AMERICAN EXPLOITATION COMPANY offers the opportunity for large profits that you are seeking. This Company's holdings are large and valuable. Its seven properties are developed and producing mines. Five are equipped with mills and reduction plants. Over \$1,250,000 was originally paid for the properties and over \$700,000 has been expended in their development and equipment. There are over 75,000 tons of ore now in sight worth over \$1,500,000. Its combined earning capacity permits of large and continuous dividends. Its "Eggs are not in a single basket." It is not a question of "Will it pay?" but, "How much?"  
\*\*\*\*\*

## IT SHOULD ALSO BE SAFE

Every purchaser of the Treasury Stock of the Company, receives, to the extent of his investment, a **FIRST LIEN GOLD BOND**, bearing 6 per cent guaranteed interest, payable on or before 5 years, secured by the entire assets of the Company—this makes your investment safe, besides effecting the return of your money within a brief period, and leaving the stock you hold, as a bonus.

The first allotment of Treasury Stock is now offered for subscription at a special "organization" price. For Prospectus, Copy of Bond and full particulars, address,

**THE WESTERN TRUST & GUARANTEE CO.**

**FISCAL AGENTS**

**New York Life Bldg.**

**CHICAGO, ILL.**

This One



S880-J1T-PEWT



# MORE MONEY

is made from  
Patents than from  
any other class of  
Investments. . .

## SUCCESS SURE

IF YOU HAVE A GOOD INVENTION  
BACKED BY A STRONG PATENT  
AND BUSINESS ABILITY.

### THE FIRST STEP

If you have made an invention and contemplate applying for a patent, the first point is to learn whether your idea is new and patentable. Do not depend on the fact that you or your friends have never seen anything of the kind. Send us a pencil drawing, showing plainly your invention, and write out a description of its construction and operation, as well as you can. If you have a model, send it instead of the drawing. We will compare your sketch or model with all patents issued in the United States for inventions resembling yours, and for inventions in which similar mechanical constructions or principles are used. If a patent is found for an invention exactly like or closely resembling your idea, we will send you a copy of such a patent. If nothing is discovered to prevent getting a patent for your invention we will so advise you.

The charge for this service, unless otherwise agreed upon by special arrangement, is five dollars. This examination is an important step in connection with every patent application and requires great care and skill. An incompetent attorney may overlook a patent which closely resembles or completely anticipates your invention, or he may not know where to look. A dishonest attorney will purposely fail to find an anticipating patent in order that he may get the fee for preparing the application. The inventor is the loser in either case.

### WHAT A PATENT COSTS

Opinion as to novelty and patentability of an invention, after thorough examination of United States patents.....	\$ 5.00
Preparing official drawing—one sheet.....	5.00
Preparing Oath, Petition, Specification and Claims.....	15.00
First Government Fee.....	15.00
Prosecuting application for patent.....	10.00
Total cost of application, first Government fee, official drawing, preparing all papers and prosecuting application in Patent Office.....	45.00
Within six months after the application has been allowed, the Government charges a final fee of.....	20.00
Thus the total cost of a patent for a simple invention is.....	65.00

Intricate inventions cost more to patent, but we will state the exact cost in advance in each case. We assist our clients in selling and promoting their patents without advance charges.

## POPULAR MECHANICS PATENT BUREAU

Main Office: Journal Building, Chicago, Illinois

Associate Offices: WASHINGTON, D. C., LONDON, BERLIN and other large cities.



# BOUND BOOKS AT SHEET PRICE

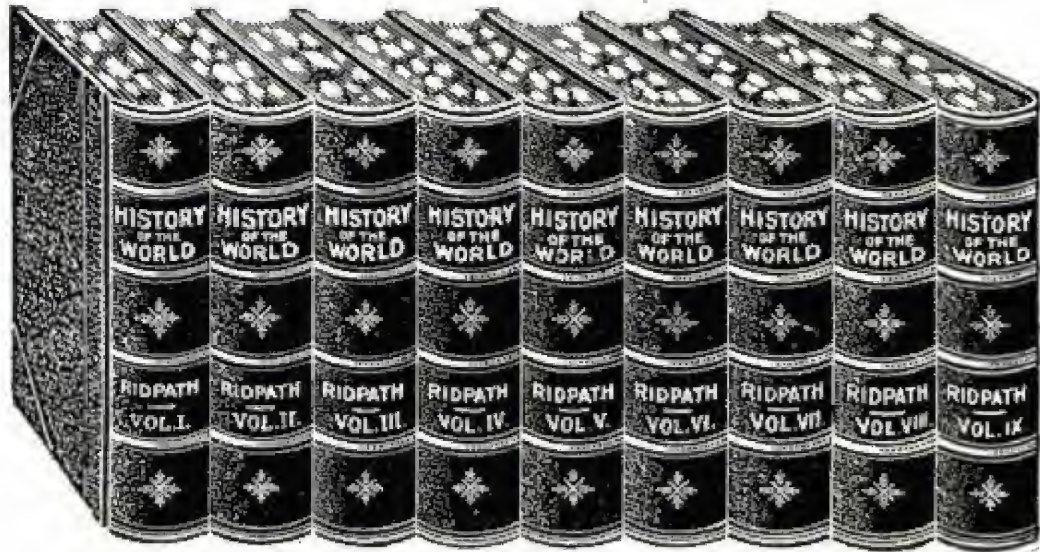

Books are Royal Octavo—About 11 inches tall

## 1-2 PRICE      **RIDPATH'S**      1-2 PRICE **History of the World**

We guarantee the volumes perfect in every way—except the color of the leather on the backs varies a trifle—the shade on a few of the volumes being a little lighter than the others. The difference would scarcely be noticeable to one outside of the book trade. **We'll send the books to you on 5 days' approval.** You'll find them satisfactory; if not, return them at our expense—nothing fairer—you see and know just what you are getting.

There are less than 20 of these sets, and rather than rebind such a small lot we prefer to send them to you on approval, and at **almost half price**—about what they would be worth to us with the covers torn off—and on payments of only \$2 a month.

### Much Money Saved if You Answer Quickly

These are just as good as are sold:

REGULAR PRICE, . \$66.00

OUR SPECIAL PRICE, 39.00

You save \$27.00 if you send coupon at once.

If you'd like to possess the only world's history that reads like a story book—yet is recognized by such men as President Roosevelt, Judge Parker, Dr. Cuyler, Bishop Vincent, and thousands more, as a standard authority and the greatest historical reference work in existence—send coupon TODAY. Ridpath will interest and instruct you. **You Need It.** This is your chance to secure one of the slightly mismatched sets at very much less than the subscription price. — Ridpath's History of the World is a great big set of nine royal octavo volumes, with 4,000 illustrations and many maps and color plates. You pay only \$1 down if you keep them. The complete set is sent at once. The rest you pay in monthly payments of \$2. **Cut the Coupon off and send it today.**

10  
S-B  
Jan.

The Riverside  
Publishing Co.,  
204 Dearborn St.,  
CHICAGO, ILL.

Please send me for inspection and on approval, charges prepaid, one set RIDPATH'S HISTORY OF THE WORLD, 9 vols., Half Morocco binding. If I like them I will pay you \$1.00 in 5 days and \$2.00 per month thereafter for 19 months. If I do not conclude to keep the set I will return it to you in one week at your expense without further obligation on my part.

Name .....

Street .....

City .....

Occupation .....

**THE RIVERSIDE PUBLISHING CO.,**  
204 Dearborn St., CHICAGO, ILL.



(ESTABLISHED 1865)

# Peabody, Houghteling & Co.

1122 First National Bank Building  
CHICAGO

Offer an unusually choice list  
of high-grade

## Bonds & Chicago City Mortgages

in convenient denominations  
of \$500, \$1000 and up, netting  
from 4 per cent. to 6 per cent.,  
and on account of their conser-  
vative and non-speculative char-  
acter specially suited to the  
investment of

## SAVINGS AND TRUST FUNDS

Send for Our Lists

# Have You Ever Considered the Practical Results

of a Savings Account in

## THE SAVINGS DEPARTMENT of

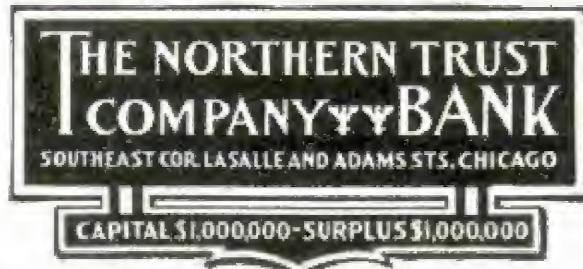

### COMPUTATIONS SHOWING ACCUMULATIONS OF MONTHLY SAVINGS DEPOSITS

OF ONE TO TWENTY DOLLARS IN ONE TO FIVE YEARS, WHEN  
INTEREST IS COMPOUNDED SEMI-ANNUALLY AT 3% PER ANNUM

Monthly Deposit	1 Year	2 Years	3 Years	4 Years	5 Years
\$1	12.19	24.75	37.67	51.00	64.72
\$2	24.39	49.50	75.37	102.03	129.49
\$3	36.58	74.25	113.08	153.06	194.26
\$4	48.78	99.01	150.79	204.11	259.06
\$5	60.97	123.78	188.47	255.13	323.81
\$6	73.17	148.54	226.20	306.19	388.62
\$7	85.36	173.29	263.90	357.22	453.37
\$8	97.56	198.06	301.60	408.26	518.15
\$9	109.75	222.81	339.28	459.28	582.91
\$10	121.95	247.57	376.99	510.33	647.70
\$11	134.14	272.33	414.70	561.37	712.47
\$12	146.34	297.10	452.43	612.43	777.28
\$13	158.53	321.85	490.11	663.47	842.06
\$14	170.73	346.62	527.82	714.49	906.81
\$15	182.92	371.37	565.51	765.52	971.57
\$16	195.12	396.13	603.22	816.58	1036.38
\$17	207.31	420.90	640.93	867.61	1101.14
\$18	219.51	445.65	678.62	918.64	1165.91
\$19	231.70	470.41	716.33	969.70	1230.70
\$20	243.91	495.18	754.05	1020.75	1295.50

Copyrighted 1904, The Northern Trust Co.

**Saving Accounts** may be  
opened  
with one dollar or more. If not con-  
venient to come to the bank, write  
for booklet, "Banking by Mail."

### DIRECTORS

- A. C. BARTLETT,  
of Hibbard, Spencer,  
Bartlett & Co.
- J. HARLEY BRADLEY,  
of David Bradley Mfg.  
Company.
- WILLIAM A. FULLER,  
formerly of Palmer,  
Fuller & Co.
- MARVIN HUGHITT,  
President Chicago &  
N. W. Ry. Co.
- CHAS. L. HUTCHINSON,  
Vice-Pres. Corn Exch.  
Nat'l Bk.
- MARTIN A. RYERSON,
- ALBERT A. SPRAGUE,  
of Sprague, Warner &  
Company.
- BYRON L. SMITH,  
President The Northern  
Trust Company.



# POPULAR MECHANICS

Vol. 7. No. 1.

CHICAGO, JANUARY, 1905.

10 Cents a copy.  
\$1.00 a year.

## Locomotive Without Fire or Water

**Would Make Crossing the Continent Without Stopping Possible.**

A locomotive without water, fire or smoke, unencumbered by the five tons of coal and 7,000 gallons of water usually carried by the steam engine; drawing no tender, but provided instead with an engine for generating electricity; a clean, strong powerful engine drawing a 2,000-ton train and

energy produced passes up the smokestack, 4 per cent goes to the boilers, and 2½ per cent only to the driving wheels. A writer in one of our daily papers states:

"Driving wheels can be made just so large and no larger. Connecting rods can be made just so long and no longer. If the

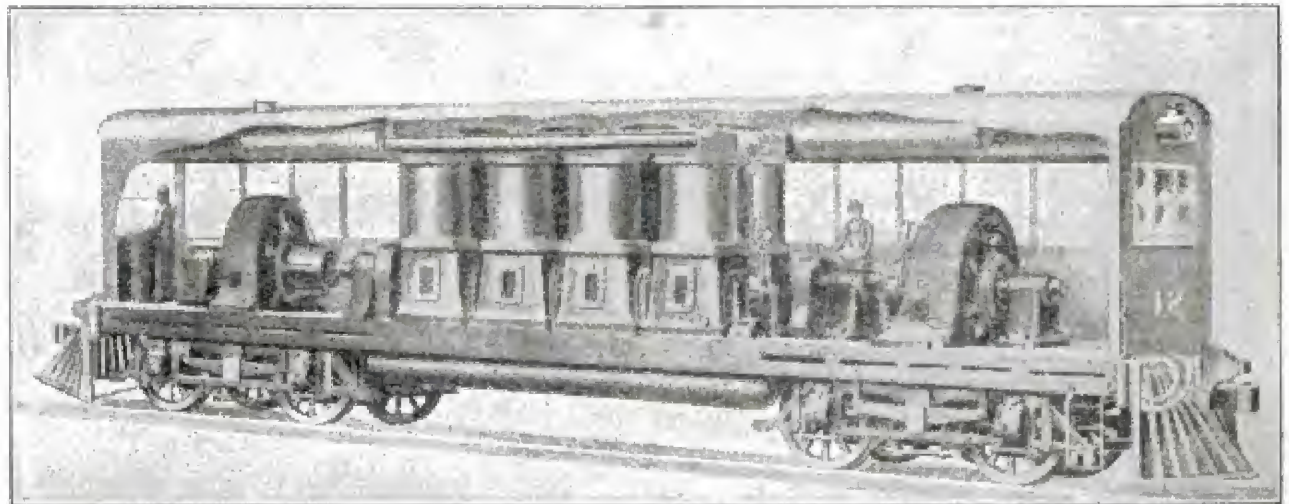

*Courtesy of The Manufacturer's Record*

**The Dream of Modern Traction--Showing Interior of Locomotive.**

speeding across the continent from New York to San Francisco, without stop or delay, and at the average rate of 100 miles per hour—this is a dream of modern traction, worked out theoretically with mathematical precision, now being constructed for the Southern Pacific Railroad and soon to be put to the practical test of a long trial run.

It is generally accepted by railroad managers that the limit has been reached in steam locomotive construction. One axiom in this line has been "a pound of weight to carry a pound of weight." Locomotives have gained 100,000 pounds in weight in the last five years, and tender capacity has been increased accordingly. Of the fuel consumed by the steam locomotive 96 per cent of the

driving wheels are giant affairs it means a tremendous weight to the machine that must come on the tracks in a comparatively small space. There is one way to 'spread the weight,' and that is to have longer connecting rods. But here a difficulty is encountered. Tractive power necessary for high speed or great draught cannot be obtained if the rods are much over 12½ feet. This fact has put steam locomotive builders between the devil of big wheels and the deep sea of the short connecting rod. If the steam locomotive could be made more compact, greater power could be obtained, but, on the other hand, the weight would be so concentrated that there is not a curve in the roadbed or a bridge on the line that could stand the strain."



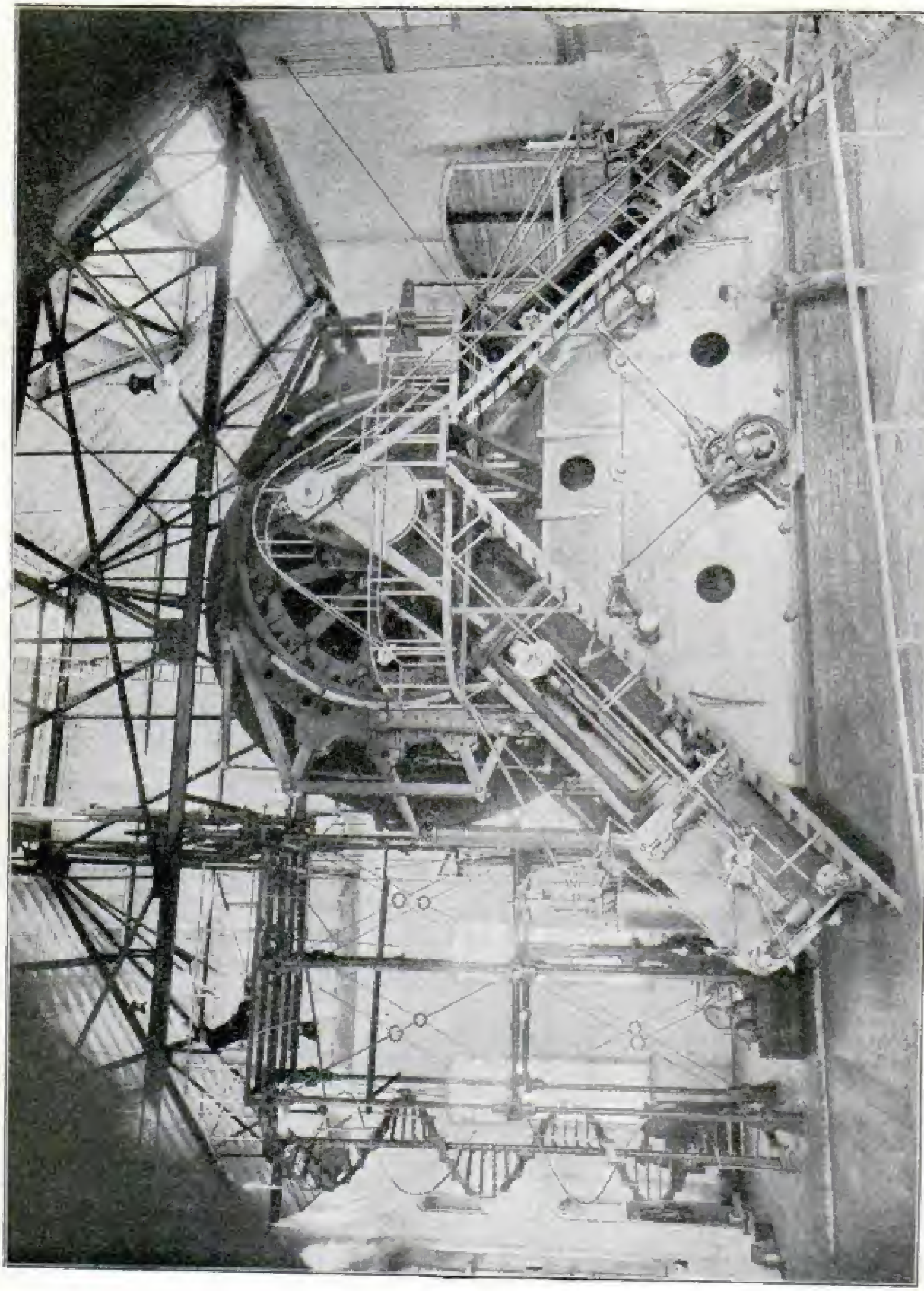

Courtesy, Worthington Manufacturing Co.

**5,000 Horse-Power Hoisting Engine for Tamarack Mine—Weight 1,200,000 Lbs.**



In the proposed new locomotive an internal combustion engine, which heretofore has been applied to stationary engine work only, will be used to drive a dynamo providing electric power for the locomotive. The internal combustion engine has a thermal efficiency of 38 per cent. There is a loss in the transfer to the generator and armatures, but 28.35 per cent of the energy "gets on to the motor and axles." In other words, the new locomotive is expected to save more than eleven times as much energy as the steam locomotive.

The principle of the new engine is summed up as follows:

"Its action is on what is known as the four-stroke cycle. There is a compressed air reservoir, from which the power is obtained for starting. This gives the piston its first stroke when it takes in air—air alone at atmospheric pressure and temperature. The second stroke compresses this air to a high pressure and to a temperature of about 1,000° F. The third stroke is what is known as the working stroke. At this point oil is sprayed into this hot incandescent air—one can hardly imagine what 1,000° F. means. The amount of oil that is sprayed in is regulated by governors. During the first part of this stroke the combustion of this oil is carried on at a constant pressure for a period which is regulated by the amount of oil sprayed in. The second part of the stroke is practically an expansion without transference of heat. The fourth stroke exhausts the gases.

"The only fuel used is the crude oil that costs from three to five cents a gallon. Petroleum or any kind of crude oil can be employed. The cost per horsepower hour is said to be less than half that for steam."

---

#### POWERFUL HOISTING ENGINE USED IN A DEEP MINE.

A 5,000-horsepower hoisting engine intended for lifting a load of something over 41,000 pounds from a depth of 6,000 feet at the rate of 5,000 feet per minute has recently been installed by the Tamarack Mining Co., of Calumet, Mich. The total weight of this powerful machine, which is of the direct acting reversible type, with a drum keyed on the main shaft, is 1,200,000 pounds and the huge drum, which has a capacity for 6,000 feet of 1½-inch rope, with its shaft weighs 300,000 pounds.

Some of the leading dimensions of the

engine are: Steam cylinders (four), 34x60 inches; main bearing, 24x42 inches; crank-pins, 12x15 inches; crosshead pins, 6½x12½ inches; diameter of rope drum, 25 feet; length of drum, 24 feet 6 inches. The cages used are double decked balanced cages, the empty one descending while the loaded cage is being hoisted. In this operation the load the engine would ordinarily handle consists of 21,000 pounds of rope; cage, 4,200 pounds; two cars, 4,000 pounds; rock, 12,000 pounds, a total of 41,200 pounds. The engine frames are of the hollow girder type, and rest on large cast-iron sub-bases, the whole being fastened to the foundations by rods.

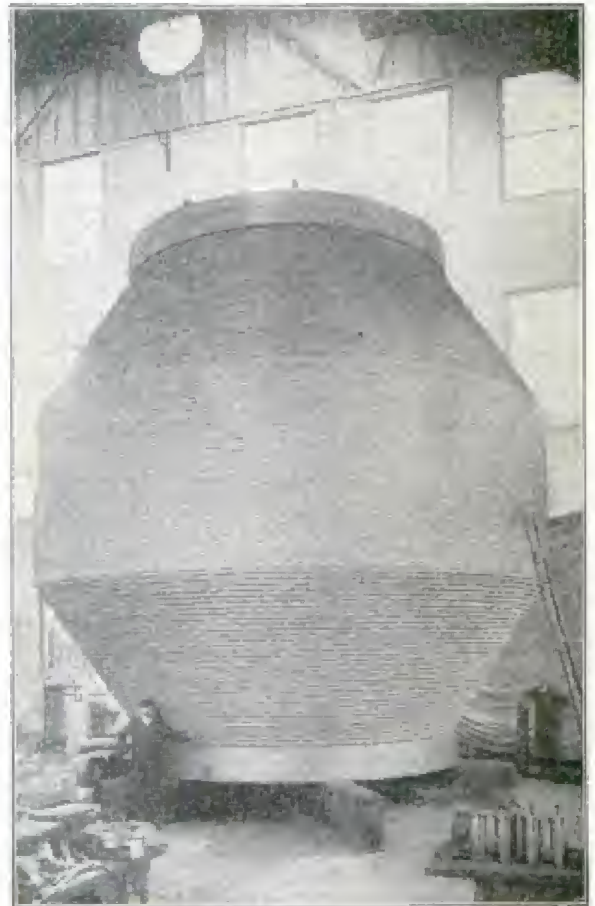

**Rope Drum 25 Feet Long**

The throttles, reversing gears, cut-off gear and brake are all operated from the platform on which the operator sits, as shown in the illustration. Here also is located the "miniatures" which indicate at all times the position of the cars and from which the safety stop is operated. By means of this safety stop the motion can be arrested and reversed whenever the cages are in danger. There are two sets of powerful brakes, one on each end of the drum. The engine may be run from one turn per minute to 54 turns per minute with an action equally smooth and perfectly controlled.



### MODEL OF VERY LARGE LOCOMOTIVE.

One of our readers, who is a railroad official, sends a photograph of a model of a very large "Columbia" type passenger locomotive. The model is made almost entirely of wood, and as shown in the illustration is a very handsome piece of work. In these days of mammoth locomotives the work is extremely interesting as showing the proportions which a machine built on the lines shown would look like. The builder says: "It is built on a scale of 30 inches to the inch, and although I realize it would not be practicable to build a machine of this size,

wheel base driving, 8 ft. 6 in.; wheel base rigid, 18 ft. 5 in.; wheel base, total engine, 29 ft. 4 in.; wheel base, engine and tender, 51 ft. 6 in.; tank capacity, 6,000 gal.; coal capacity, 12 tons.

### THE LARGEST TROOPSHIP IN THE WORLD.

The "Dufferin," the largest troopship in the world, was recently launched at Barrow, England. The vessel will accommodate 1,520 persons and in equipment is equal to a first-class liner. Sanitary and ventilating

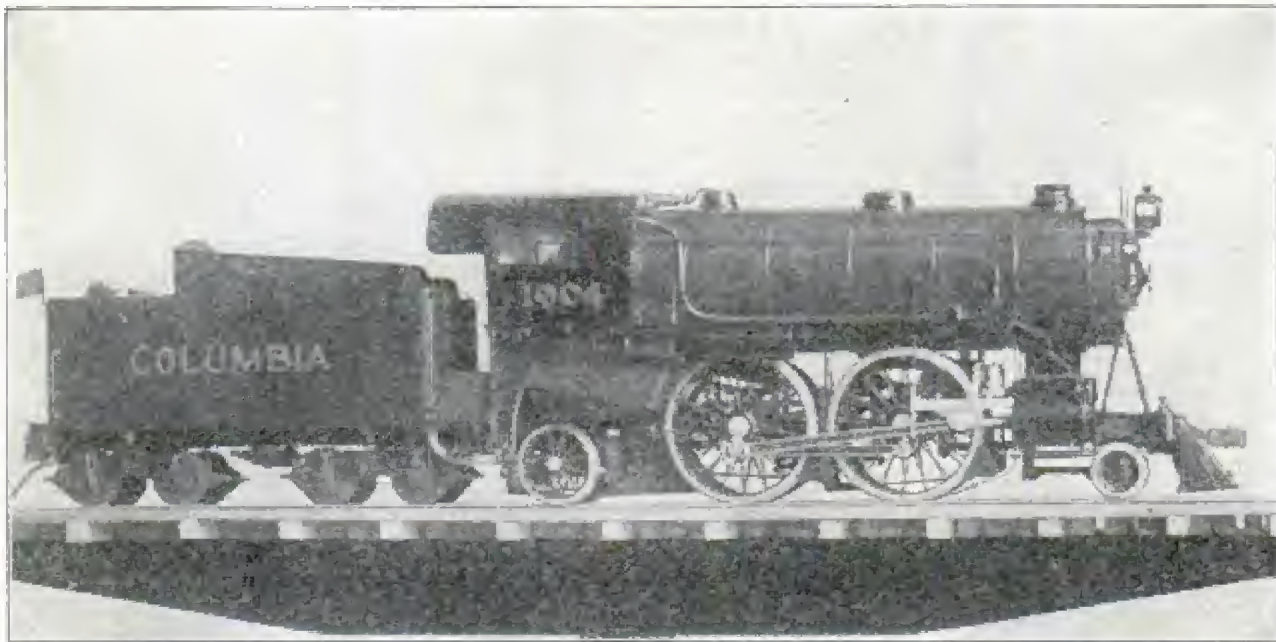

Copyright 1904.

**"What the Real Thing Actually Looks Like."**

I take delight in showing some of the would-be big engine advocates what the real thing actually looks like."

The bigness of the thing is better comprehended in the driving wheels, which are 7 feet 10 inches high, and the height to top of boiler, 15 feet 3 inches. To save height the stack is only 1 foot high, and the bell is hung below the boiler. The main dimensions are: Cylinders, 26 x 30 in.; boiler, diameter smallest ring, 84 in.; firebox, length, 70 in.; firebox, width, 90 in.; flues, 460; flues, length, 18 ft.; driving wheels, diameter, 94 in.; trailing wheels, diameter, 52 in.; pony truck wheels, diameter, 33 in.; weight on driving wheels, 145,000 lbs.; weight, total engine, 225,000 lbs.; weight total engine and tender, 340,000 lbs.; height center boiler, 11 ft. 9 in.; height top boiler, 15 ft. 3 in.; height top stack, 16 ft. 3 in.;

arrangements have been most carefully made and all that would tend toward the comfort and health of the soldiers has been provided, the vessel being model in this respect.

The ship is of the spar deck type, length over all, 453 feet; breadth, 52 feet, 6 inches; moulded depth, 39 feet. It has four complete decks and a boat deck about half its length amidships. It can be made practically unsinkable in a few seconds by closing the water-tight compartments into which it is divided under the main deck. These are controlled from the bridge. The propelling machinery, says the Marine Engineer, consists of two sets of inverted, vertical, direct-acting, triple expansion engines, each set having three cylinders, working on separate cranks, and capable of developing 9,400 horsepower at 115 r. p. m.



### TRAGIC FATE ENDS "FOOLKILLER NO. III."

#### Nissen Crosses Lake Michigan in a Furious Storm at Night, but Finds Death on the Farther Shore.

Peter Nissen has met the fate with which he has flirted for years; yet he should not be classed with the ordinary seeker after notoriety. The adventurous blood of the old Norsemen coursed through his veins and impelled him to deeds which other men shuddered to even contemplate.

In the July, 1904, Popular Mechanics a detailed description was given of Nissen's balloon-boat, the "Foolkiller No. III," and an account of his first voyage, which for lack of wind, was uneventful. This craft was a mammoth canvas ball 22 feet in diameter and 32 feet long, inflated by means of an air pump. A shaft extended through the center from end to end and from this suspended a swinging cradle in which Nissen sat or reclined.

His expectation in event of a successful voyage across Lake Michigan was to construct a much larger ball, 75 feet in diameter and 115 feet long, which was to be taken to the extreme limit of northern



**Peter Nissen**

travel, and then used in rolling to the North Pole. His theory was that the lightness of the craft when driven by the wind would cause it to go bounding over obstructions many feet high, precisely as a thistle-down travels.

Nissen, who was a frequent visitor at this office, called the afternoon before his fatal trip, but it was characteristic of the modesty of the man that he made no mention of the coming trial. Ever since his remarkable trip through the rapids at Niagara he has been offered large sums from amusement managers, but the idea was very repugnant to him, notwithstanding his need of money for experiments. He was a college graduate with honors.

The ill-fated trip was made on November 29, during a furious winter gale blowing from the west. The storm was so severe that steamers due to leave this port dared not venture out. He entered the ball about 4 o'clock just as dusk came on. The opening was sealed to make it air tight, and at the word from within the ball was released and rolled rapidly down the sea wall and in a few minutes was well out at sea. Nissen carried provisions for two days, but removed his overcoat as he entered the ball. He declined assistance from a passing tug two miles out. At midnight the gale was blowing nearly 50 miles an hour and the cold was intense.

Two days later the frozen body of Nissen and the remains of the ball were found tossing in the surf of the east shore 100 miles from Chicago. He had evidently made the crossing in safety, but the ball had failed to roll out of the water up on to the shore, and the intrepid inventor after cutting his way out of the balloon and in an exhausted condition had been unable to stand against the breakers, and so perished in the surf.

To provide for the natural deflation of the ball through leakage, and also to supply



This Picture Shows the Start of the July Trip of Nissen—Leaving Chicago Harbor—It was in the Same Ball that Nissen Lost His Life.



fresh air to breathe after 15 hours' occupation, an air pump was attached within the ball connected through a small hose to the outside. Something happened to the hose, for in his pocket was found a card on which were written the words "Air hose has broken. N."

It is believed the reason the ball failed to roll out of the lake onto land was on account of its being deflated to perhaps one-half its normal size. The funeral, in Chicago, was attended by 4,000 persons.

---

### DULUTH AERIAL FERRY.

---

**Only One in America—One of Five in the World—  
Suspended Ferry Carries Street Cars,  
Vehicles and Pedestrians.**

---

The great aerial ferry in Duluth will be placed in commission this month. Nearly a year has been spent in construction and erection. It is the only structure of its kind in America, and one of only five in the world. The others are at Newport, England; Rouen, France; Bizerte, Tunis, and at Nantes, France, over the Loire. These ferries were fully described in Popular Mechanics for March, 1904.

The purpose of the aerial ferry is to afford nearly all the advantages of a bridge

without any of its disadvantages to shipping. This ferry crosses the Duluth ship canal, where a center pier swing bridge would impede navigation. In the aerial ferry a huge steel trussed superstructure spans the channel, the distance between the towers being 393 feet. Tracks are laid on the bridge span on which run trucks from which depend 1½-inch steel cables, which in turn suspend the car or ferry. The distance from water line to the lower beam of the span is 185 feet, which enables vessels to pass below with clearance for their main masts. The only false work used is the support under the first section of the towers.

The car or ferry is moved from tower to tower by electric motors in the trucks running on the overhead tracks, but controlled by an operator on the ferry below. The ferry swings clear of the water and a few feet above, and the floor is on a level with the city streets. Space is provided for several wagons or vehicles, or one double-truck street car, and cabins at each side are fitted with seats for passengers. The ferry car will carry 300 persons. The ferry is at all times under the control of the operator by means of a controller similar to that used on street cars. The trip is made at a speed of about four miles an hour, and a load up to 50 tons can be carried. The bridge is built to withstand a wind velocity of 70 miles an hour, and cost \$100,000.



**Ships Pass Under the Ferry Without Delay**



### MEASURED SERVICE METERS FOR TELEPHONE PATRONS.

Individual measured-service meters for telephone users are becoming quite popular the meter being always an arbiter of peace, and settling all disputes in a manner satisfactory to both parties. Our illustration shows the simple apparatus which is placed in the subscriber's station and which registers each call as it is made. The device works as follows:

When a connection is made, the subscriber calling pulls a lever which throws a buzz over the wire and notifies the operator of the call. The call is also shown on the face of the meter.

The record of the meter is read at the end of a stated period. To do this the central office places its machine in connection with the subscriber's meter and the subscriber is called and asked to turn a crank. This operation takes a statement of the



#### The Patron's Instrument

number of calls since last reading on a tape by Morse code at the central office. The whole apparatus is completely under control of the telephone company and can be attached without extra wiring. The maintenance cost, says the Western Electrician, is very slight and one portable statement-taker will do the work for an entire exchange.

### UNSINKABLE LIFE-BOATS.

An unsinkable life-boat, unsinkable even though seriously damaged, is the product of a Danish inventor, and several important features are claimed for the new craft.

This life-boat consists of a boat-shaped pontoon of wood or iron, strongly constructed, and filled with kapok, a product of plants growing in Java and Sumatra, said to combine the greatest floating capacity with the least weight and able to sustain thirty-five times its weight in water.

The kapok is contained in water-tight cushions which in turn are placed in water-tight compartments. Upon this buoyant layer is mounted a superstructure which can be folded down or erected. This is surrounded by a fender filled with kapok in water-tight cushions. In extending the boat, cross



#### Unsinkable Lifeboat Extended for Use

beams are lifted in and the oars are released, an oval-shaped thwart with cross-thwarts slides into position, and stanchions and other parts drop into their places automatically, making a reliable boat containing bread and water-tanks.

Exhaustive tests have been made of the Englehardt unsinkable life-boat, as it is called, and it has stood successfully every one. It is compact for carrying on vessels, where space occupied is an important consideration, and if a ship were to sink suddenly these boats would only need be cut from their lashings and would be



#### The Boat Folded.

found floating after such disaster, still fit for use and easily accessible by those in danger of perishing. The boats can, moreover, be readily transported to any part of a ship and launched without davits.

The ordinary lifeboats take up so much deck space that it is impossible to carry enough for passengers and crew, and as a consequence the boats are apt to be overcrowded and swamped.



### CONSTRUCTING A TALL STEEL SMOKE-STACK.

In our illustration is shown an exciting stage in the construction of a tall steel stack—the erection of the last section. This



**The Critical Moment.**

stack is on the power house of the Fond du lac-Oshkosh Interurban Railway and is 140 feet high and eight feet in diameter. The brick stack near it is 120 feet high and seven feet in diameter.

### STEEL TIRES AND SPRING WHEELS FOR AUTOMOBILES.

The solution of punctured rubber automobile tires is announced by an invention which replaces rubber tires with steel, and provides the same resiliency by means of coil springs at the hub.

The hubs of the new wheels are made of cast steel, with hickory spokes and white oak felloes. The inner hub has a wide projecting flange which runs into the outer hub and is held in place by a screwed steel ring, this makes a running fit to the metal flange and prevents all side thrust. Fastened to the outer hub are six square bolts the threaded ends of which, with their nuts, hold steel saddles in position. On the outer side of the spokes these saddles carry two spiral springs whose opposite ends are fastened to the inner hub. The springs are held at both ends by lugs and if a spring breaks the nuts may be taken off and the spring readily replaced, the cost of a new spring being about 15 cents. Steel tires are very durable and economical, but make considerable noise. Wheels may be equipped instead with channel iron in which is laid  $\frac{3}{4}$ -inch hydraulic packing. Such a tire is



**Hub Springs Replacing Rubber Tires.**

noiseless, has great adhesion and the cost is less than that of solid rubber. The firm making these wheels guarantees them to be as resilient as any wheel with a pneumatic tire. If the new wheels stand the test of time and use, automobiling will be relieved of a few of its difficulties.

The number of telegrams sent daily throughout the world reaches the enormous total of 14,000,000, not including 36,000 cable messages, according to George Johnson, official Canadian statistician.



**PORTABLE WATER DISTILLING PLANTS.**

The most important requirement for preserving the health of the human body is a sufficient supply of pure water for drinking and cooking purposes. Especially is this true in arid regions or in low swamp country where one is apt to drink death with a cup of such water as is obtainable there. Often in these places large gangs of men are employed, the labor of every one of whom is indispensable. This is the field into which the invention shown in our illustration will enter and be found most welcome.

discharged from the separator of the first vessel into tubes of the second, owing to the difference in pressure in the two vessels or effects. The steam from this last effect, along with the drip-water from the second shell, passes direct to the condenser, and is discharged as pure distilled water. If the local water is unfit for boiler feed purposes the drip-water—or "boiler steam condensed"—from the first shell after passing through the feed heater, discharges into the boiler-feed tank, and is pumped back into the boiler. If fit for boiler-feed purposes the drip from the first shell is used for heating in the second shell and goes to further in-

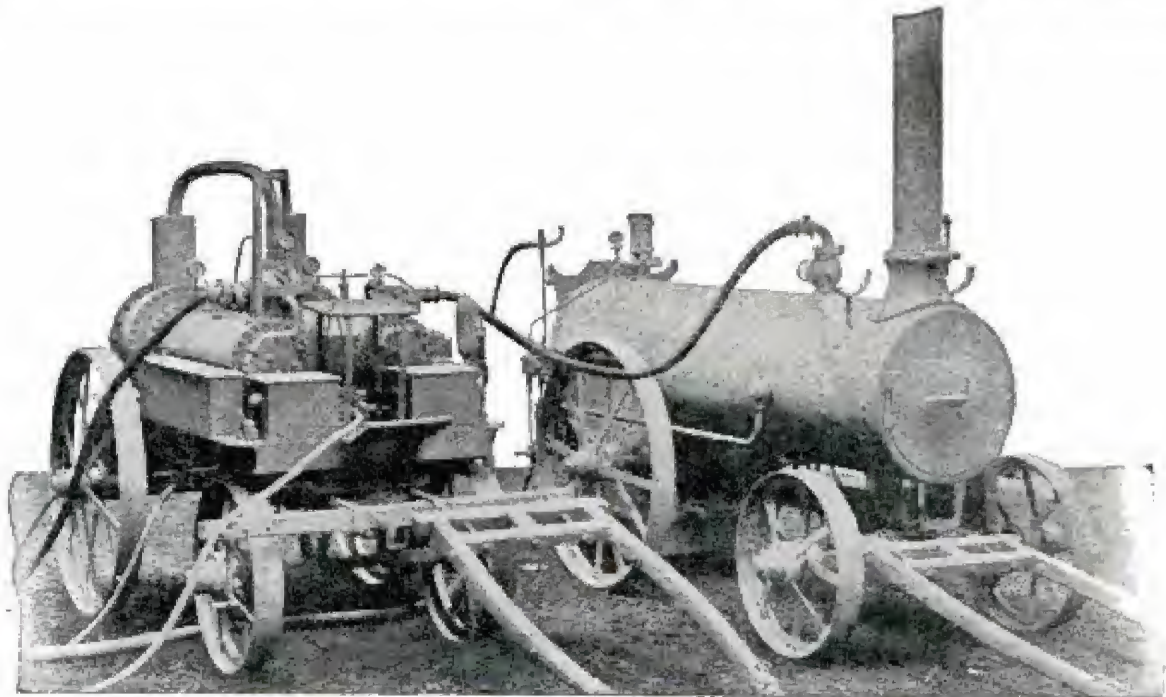

**Produces 65 Gallons of Pure Distilled Water Per Hour**

This plant will convert undrinkable brine or any other impure water into the health-giving fluid at a rate of 65 gallons pure product per hour, not including the condensed "boiler steam" or "drip" from first shell.

The apparatus while working requires very little attention. The process is much as follows:

The impure feed-water (drawn from the condensed overflow) is pumped through a feed-heater, and is heated by the drip-water from shell of first vessel, on its way to the latter, where it passes through a series of tubes exposed on the outside to steam from the boiler. The steam rising from the impure water passes from the separator to the second shell where it heats the impure water contained in the tubes of the second vessel—this impure water being continuously

crease the quantity of distilled water.

The steam boiler, which is of the portable, "loco-tubular" type, is suitable for a working pressure of 80 to 100 pounds per square inch. The fire box is extra large, suitable for burning wood, which would be, in many localities, the only fuel available, or at any rate, the most convenient fuel.

This type of distiller is made in three sizes—28, 47 and 65 gallons of pure distilled water per hour. It is securely mounted on a strong carriage, constructed of light steel framing and suitable for animal haulage. Page's Weekly, London, says the type was especially designed for the use of prospecting and exploring parties, temporary hospitals, and for visiting and supplying fresh water to small mining stations.



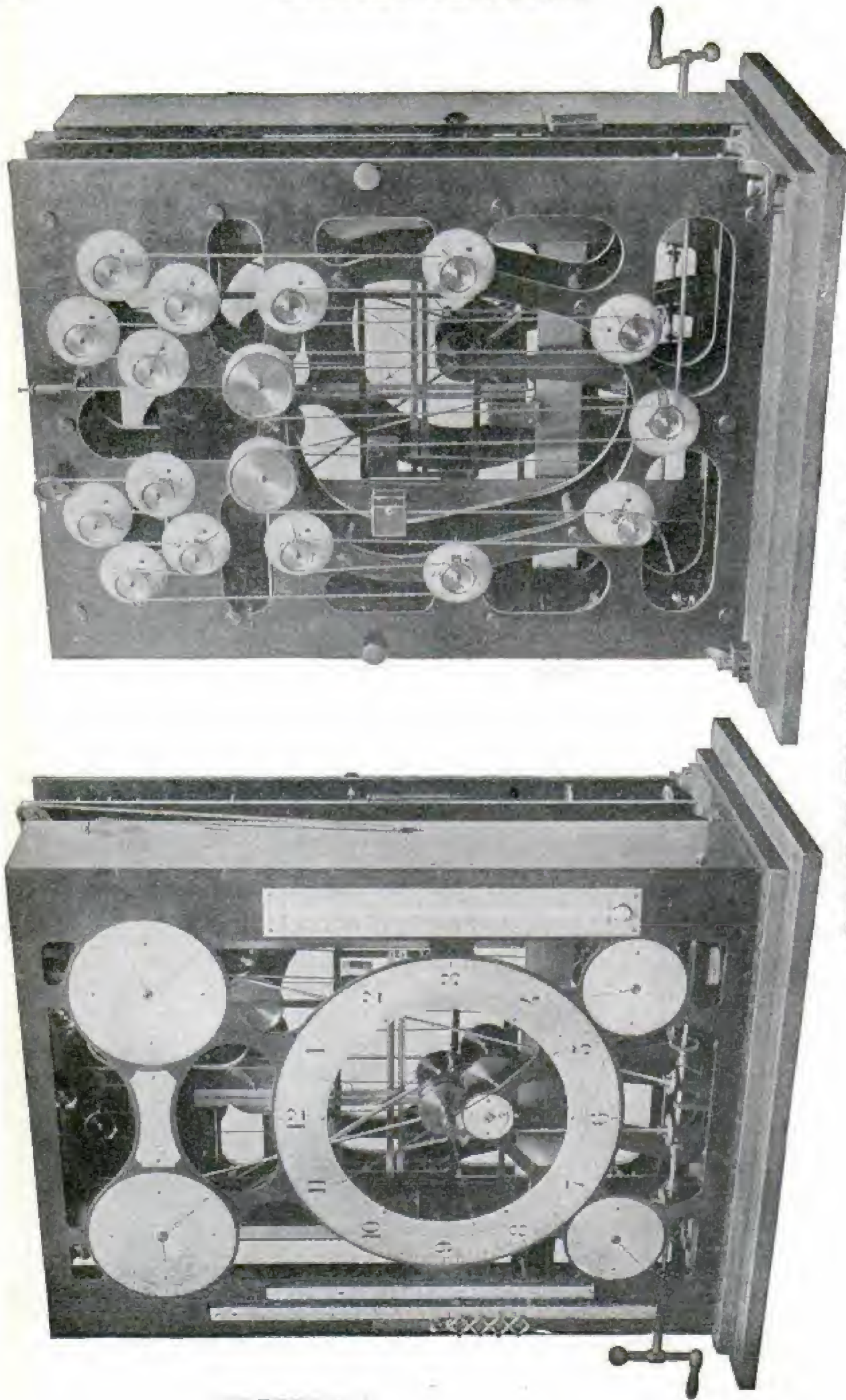

Remarkable Tide-Calculating Machine



## Wonderful Instrument Which Predicts Tides

**Built by the Government, It Performs Calculations of the Most Intricate Nature with Accuracy and Despatch**

The Secretary of the Navy desires to order a battleship into a certain harbor on our coast, at a particular hour some day next week. The harbor is entered only by crossing a bar at its mouth where the water is none too deep. He wants to know how many fathoms of water will be on that bar at the time the ship will cross it. There is a machine that can tell him in a few minutes, and whose calculations are absolutely accurate.

There is being built in the instrument shop of the Coast and Geodetic Survey Building in Washington a most intricate and wonderful machine, something that will approach "thinking mechanism" nearer than any other apparatus owned by the Government. This wonder is a tide-predicting machine, and is a great improvement—made by Mr. E. G. Fischer, chief of the instrument division of the survey—on the original one now in use for this purpose. It already displays a wilderness of wheels, slides, cranks, pins, chains, etc.; is composed of brass (the framework), and weighs several hundred pounds. Before saying more about this it is best to tell something about tides.

In forecasting tides it is necessary first to gather data upon which to work. This is done by observations at tidal stations on coast, lake, river and other shores. By long series of observations of rise and fall of tides, weather conditions and land configurations, the action of the tides is resolved into fairly constant factors for each tidal station. Long series of such observations are necessary because the tides are very complex phenomena, being modified by all influences acting upon the earth from without, as well as by those arising upon the earth itself (such as winds, earthquakes and variations of the atmospheric pressure), by irregularities in the coast line, by the eccentric distribution of the land masses, and by the varying depth of the sea. With this data taken in connection with astronomical conditions—particularly of the sun and moon—it is possible to predict the future condition of the tides.

But this involves a tedious process in hand-work mathematical calculations, which, by the elimination of certain factors governing tides and adoption of other (constant) ones, can be avoided, when a tide-predicting machine is employed. The ma-

chine used by the U. S. Coast and Geodetic Survey has nineteen dials on its back, which have to do with as many tidal factors; the latter are indicated on the dials by means of setting pointers, and when an attached crank handle is turned, indicators on five dials on the front of the machine point out the information desired. Of course, the machine is set for each tidal station, and gives high and low water time, height and depth of tides, etc., for dates far ahead.

All this is done by the many wheels and shafts of the machine operated by a steel chain that runs upon the pulley at the end of each shaft, also operating simultaneously the pointer-shafts of the front dials. This machine does the work of forty computers. It costs \$3,500.

The new tide-predicting machine will be far superior to the one described. It will have to do with thirty-nine factors of a tide instead of nineteen, giving besides time of high and low tides and their depth and height, the state of the tide at any hour. In addition to increased advantage in the sight-reading dials the new machine will plot the tidal curves on paper, and in time it is possible that added mechanism will automatically turn out printed tidal information. As above mentioned the tide-predicting machine is operated by means of a crank—hand-power. The new machine will be run by clock-work. The chain and pulley feature will be much the same in both the mechanical predictors.

It is rather a wonderful machine which takes facts and figures on its back and displays the solved problems on its front faces. The new mechanical wonder will do more. It will accomplish several things at one time—carry on two summations—one of which, at any instant, will denote the height of the tide or surface of the water, while the other will determine the time of high or low water and trace tidal curves. In other words, by looking at the face of the machine at any particular time the true height of the tide can be read off at once and times of high and low water will be given as they occur. The tracing of the tidal curves while the predictions are going on will be a valuable feature of the machine's work, for if any peculiarities or uncertainties are involved in the tide the record can be consulted.



## Ore Unloaded Automatically

**Big Clam-Shell Buckets Unload Ten Tons at a Single Operation--Make Big Reduction in Cost of Handling Ore**

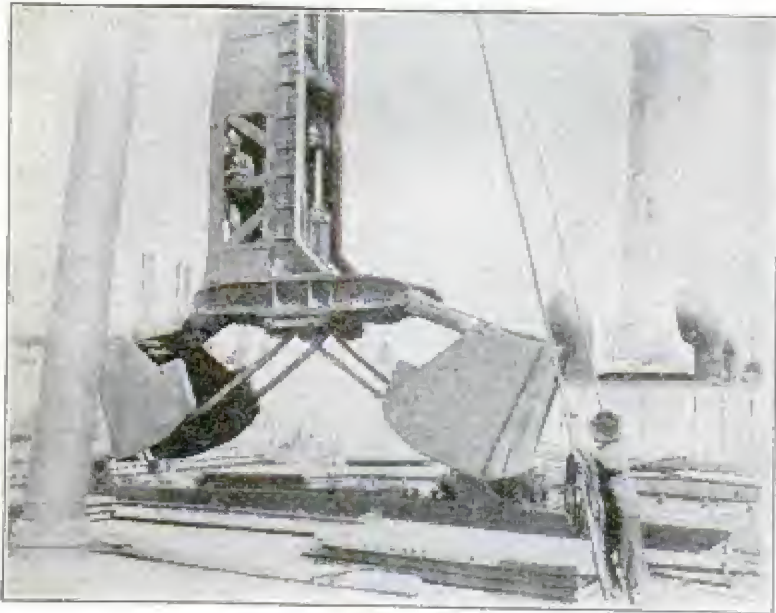

**Clam-Shell Bucket Open**

A few years ago had that monstrous fresh-water vessel, the "Augustus B. Wolvin," been in existence and landed at any lake port with a full cargo of bulk material, it would have required a period of time to unload the vessel entirely disproportionate to the admirable mechanical equipment of that Great Lakes' pride. For the cubical capacity of the "A. B. Wolvin" is about 500,000 cubic feet, equal to 401,000 bushels of grain or 12,500 tons of coal.

The "A. B. Wolvin" is almost automatic in every feature and yet the ponderous new machine which unloaded her cargo at Conneaut, Ohio, a short time ago is even more wonderful than the new ship. From the moment at which the steel plate sliding hatch covers, operated by steam engines and shafting, with which the big vessel is fitted, slid back so that the queer clam-shell bucket of the automatic ore-unloader might be lowered into the hold, until the moment when the last ton of a cargo of 7,257 gross tons of iron ore was transferred to the railroad cars on shore ready to be carried to the iron-making

plants of Pennsylvania, was exactly four and one-half hours—a rate of 1,613 tons unloaded per hour.

The "A. B. Wolvin" is, however, especially adapted in construction to the use of the ore unloader, and such speedy handling as that mentioned could hardly be maintained with a vessel of different construction. The hold of this vessel is hopper-shaped, that is, with slanting sides, so that the ore to the last ton by the force of gravity is always so disposed within the hold that the clam-shell buckets can readily handle it.

For many years inventors, engineers and experts strove to devise a means by which ore which was conveyed from the mines and loaded on the vessel in a minimum

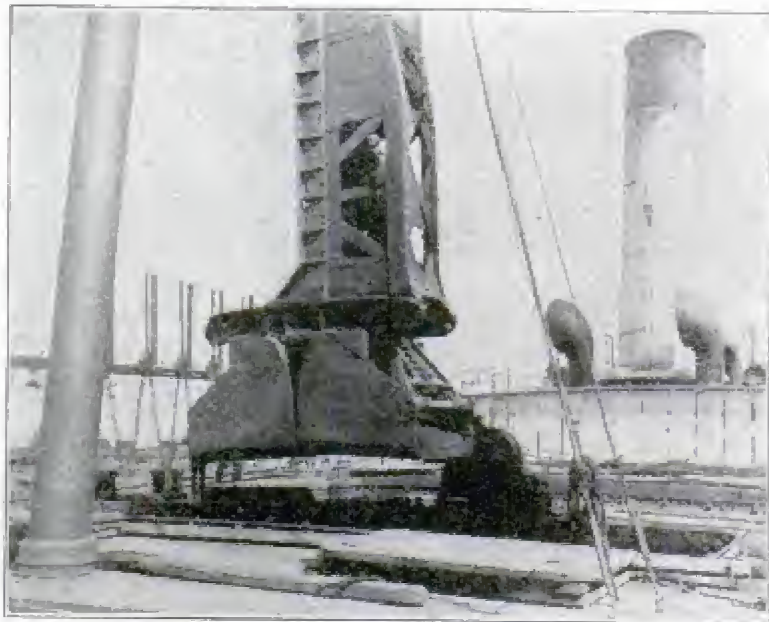

**Clam-Shell Bucket Closed**

of time could be unloaded in a proportionate time. The ore unloader which was finally successful was the invention of Mr. George H. Hulett, and while others had previously worked along the same lines as those he persisted in, they finally abandoned the idea which he brought to a triumphant success.





**The Bucket Leg with Bucket Open and Ready to be Lowered into Vessel's Hold**

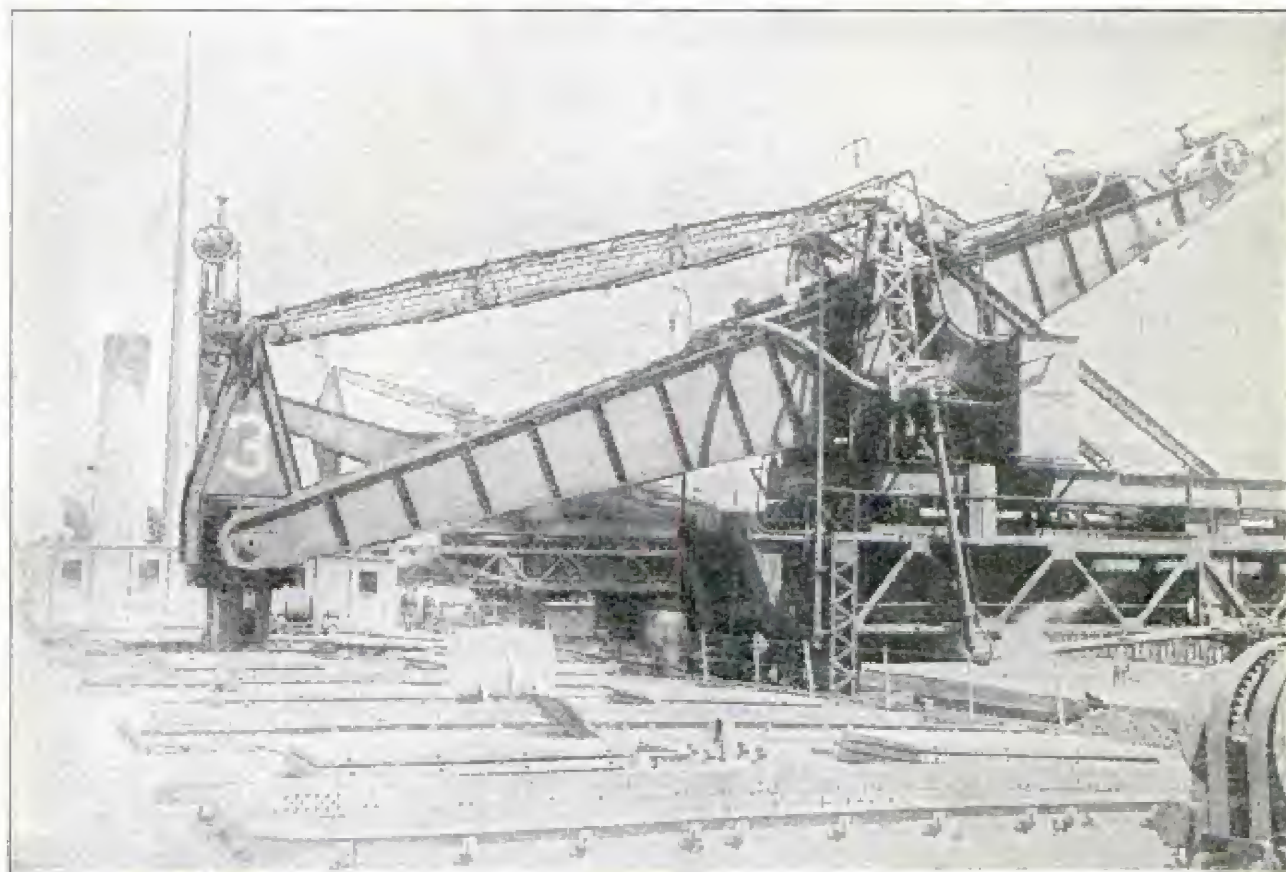

**How the Bucket is Lowered into the Hold—Showing the Operation of the Walking-Beam**



The first ore unloader of this kind was installed on the docks of the United States Steel Corporation at Conneaut, Ohio. A foundation trestle, which is mounted upon wheels, may be moved bodily along the dock to any point required. Its forward end travels on rails which are at the water's edge of the dock. A heavy walking-beam supported on a movable trolley moves backward and forward on the parallel girders of this foundation span and at right angles to the dock. To the end of this walking-beam, which is designed to extend over the vessel to be unloaded, is a depending leg to which is attached the clam-shell bucket which unloads the ore, and which is always kept in a vertical position by the parallel motion.

According as the back end of this walk-



**The Clam-Shell Bucket Scooping its Load in the Hold of the "Augustus B. Wolvin"—Showing Hopper-Shaped Hold**

ing-beam is pulled down or released, so is the front end raised or lowered, thus raising and lowering the bucket-leg in and out of the hatches of the vessel. The bucket-leg can, of course, be lowered into any hatch of the vessel and the bucket can be rotated in a complete circle. The operator who controls all the operations of the bucket is stationed in the mast or leg just over the big clam-shell.

The bucket is carried back and forth, along the girders of the foundation, out over the boat for a load, or back again to deposit it in the empty cars. Large hydraulic cylinders carrying 1,000 pounds water pressure perform all the operations of the machine, except the travel along the dock. The clam-shell bucket has a spread of 18 feet and usually descends into the hold of the vessel half-closed, though in

some special cases it is entered open. When spread out below deck its big jaws have a scope one would hardly expect, reaching from the center of one hatch to the center of the other. It can be rotated within the hold, so that practically all the material to be unloaded is within its reach.

Suppose a vessel were in port to be unloaded, the big machine is first moved opposite a hatch and the walking-beam and trolley are run forward so that they reach out over the boat. By slacking off the hoist cables at the rear end of the walking-beam the bucket is lowered until it comes in contact with the ore. After the bucket has secured its load it is then closed by hydraulic power, not only having bored its way into the ore but closing while embedded in it. The back end of the walking-beam is then pulled down again, thus lifting the front end with its load. The trolley runs back, carrying the huge beam up the dock to the waiting cars, into which the ore is discharged, or the ore may be dumped on stock piles at the dock.

All these operations have been under the direct control of the man in the mast, where are grouped all the operating levers. The bucket carries about 10 tons of ore at each grab, and under the least favorable conditions the machine can unload 2,000 tons per day.

The machine, which is a heavy steel structure, the principal members being of plat and girder construction, stands 55 feet in height and weighs 400 tons. It is moved along the dock from hatch to hatch of a vessel, or from vessel to vessel by a pair of engines which are geared to the wheels on each main leg of the structure. It greatly decreases the cost of handling ore, the cost being about nine-tenths less than with hand labor.

---

#### BELGIAN GOVERNMENT BUILDS TURBINE STEAMER FOR MAIL SERVICE.

---

The Belgian government is building a turbine steamer for the Dover-Ostend mail service. The vessel is designed for a speed of 23 knots and will be driven by three Parsons turbines developing 12,000 horsepower. The Marconi system of wireless telegraphy will be installed and will be at the service of the traveling public as well as for official use. The dimensions of the vessel are: Length over all, 357 feet; length between perpendiculars, 344 feet; beam, 40 feet; depth from promenade deck to keel, 23¼ feet; draught, 9¾ feet.



## Under-Water Armor for Battleships

### Protection Against Submarine Attacks A Momentous Problem

Submarine weapons of destruction together with accurate long-range gunfire are rapidly dispelling the fond conviction that battleships need no protection below the waterline, the water itself being their best safeguard. In the present war between Russia and Japan it has been observed with a marked uneasiness that the Japanese seriously injured several of the Russian vessels at or below the waterline in long-range firing. The fact is significant. In the great game of nations it is impossible that warships can long retain a single vulnerable point with any degree of safety. Someone will find a means of striking at that spot and striking hard. Already range-finders of a reliable character are making gunfire effective just below the armor plating.

There are many instances where the unarmored bottom of the vessel may be exposed. A vessel having six feet of armor belt extending below the water would be exposed at the unarmored portion of the bottom by a very small angle of inclination in still water, if her stores, ammunition or coals were expended. Rolling and pitching or even a seaway of moderate rise and fall may serve to expose her. Sir William White in the Naval Annual declares that it would be folly to regard the unarmored portions of the bottoms of ships as safe from all attack of gunfire. If it is folly now when there is no gun in existence which can send a projectile any distance under water before it ricochets and goes bounding along the surface with its force expended, how much will that danger be increased if ever the need expressed not long since by a noted admiral be filled: "We want howitzers firing shell at an elevated trajectory, which will explode at a given depth beneath the water."

The dangers from gunfire below waterline are, of course, slight when compared with the dangers from under-water attacks by torpedoes, and it is protection of the submerged parts of the vessel from these attacks that is now claiming the most serious attention.

Gunfire is less effective against submarines than it is against battleships below waterline. It may carry away the submarine's periscope so that observations

can no longer be made from the little craft, but it cannot damage the boat's power of maneuvering under water. In an essay Commander Murray F. Seuter of the English navy points out just what war vessels have to fear from under-water destructive forces and relates some of the methods of protecting the vessel from these forces.

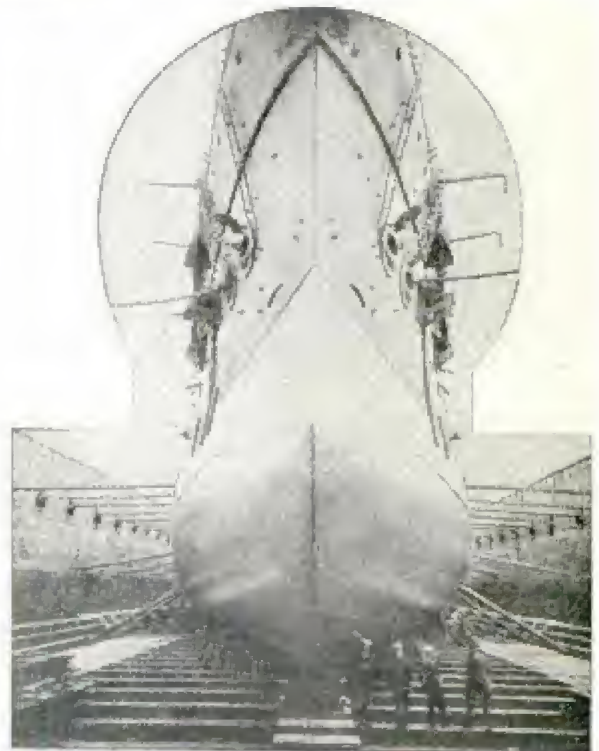

**Battleship in Dry Dock, Showing Hull**

The defects of present submarines are low speed, small radius of action, limited range of vision and enervating effect on crews, but with all these defects they are the greatest menace to the war vessel. When the submarine must come to the surface to take bearings, rapid gunfire from a battleship would soon destroy it, but the submarines now in use do not come to the surface. The torpedo boat destroyer is at a disadvantage against the submarine because it offers a large target both to under-water and surface vessels and is soon put out of action by gunfire and the crew are unprotected. The method of dealing with the submarine most commonly used is to attach a spar of gun-cotton charge to the quarter of a destroyer, which chases the





**Submarine Boats, the Battleship's Greatest Foes, Maneuvering Before the King at Portsmouth, England**

submarine as soon as it is sighted. The spar is swung out and when over the submarine it is detonated. This method is only effectual when the submarine is seen. Entanglements by nets or hawsers; injury from a gun-cotton charge; exhaustion of electric batteries; defects to internal mechanism; defects to external gear of diving rudders; bad fumes, producing the collapse of the crew; or a porpoise-like rise and dive to obtain bearings when the periscope has been shot away, these are named as causes for the submarine rising to the surface where it is possible to injure her.

Protection against torpedo attack has become an important consideration in the construction of the war vessel. Numerous methods have been tried to render the vessel proof against a torpedo explosion several feet below the waterline. The British navy now has a 3,000-yard torpedo; the Austrian Government have been experimenting with one having a 3,800-yard range. The torpedo has become the most deadly weapon of warfare. The strongest searchlights have a range of about 2,000 yards; a destroyer 1,800 or even 1,000 yards outside this range has the best of the chances for discharging its torpedo. Commander Senter declares that "rigid armor

plates, with many butting joints and armor bolts, are no defense against the shattering effect of a torpedo." Wing bulkheads, that is, armored inner bottoms fitted a few feet inside the outer skins, which are of thin steel plating, have been tried on some of the modern war vessels, notably the "Cesarevitch," seriously damaged in a Japanese attack on Port Arthur, but this protection is decried because of the danger of water-logging of spaces outside the armor protection, but inside the ship, resulting in serious heeling of the vessel, or, possibly, in absolute instability.

Recently the old British battleship "Belleisle" was sunk in Portsmouth harbor by the explosion of a torpedo under her hull, and so disastrous was the effect of the explosion that it took a month to get the vessel afloat again, although she was only in shallow water. The object of the torpedo experiment was to ascertain whether cellulose material made of corn pith could be relied upon to prevent the inrush of water when a ship had a big hole knocked in her bottom. Accordingly on "Belleisle's" hull, ten feet below waterline, a section had been constructed representing the double bottom of a modern battleship, and this was packed with cellulose. The "Belleisle" was towed to Fareham



creek, in Portsmouth harbor, and a torpedo warhead charged with guncotton exploded under the false bottom by officers of his majesty's ship "Vernon" at the Portsmouth torpedo school. Not only was the false bottom blown to pieces and the cellulose sent high up into the air with the volume of water that followed the explosion, but a big hole was also made in the ship's bottom. The Liverpool Salvage Company undertook to raise her, but the task has been a difficult one, owing to the soft nature of the bottom. As fast as the mud was cleared away to enable the divers to work up the rent, the next tide would bring more mud back. At length a cofferdam was constructed inside the ship, and eight pumps, each capable of discharging great volumes of water, were kept at work, with the result that the old battleship was floated and placed in dry dock. It was evident that she had sustained serious damage, for the vessel had a big list to port as she was being towed across the harbor, and two pumps were discharging an immense volume of water out of her. When the dock had been cleared of water the damaged part of the "Belleisle's" hull was carefully covered up with canvas, so as to prevent unauthorized persons from becoming acquainted with the extent of her injuries.

Water or compressed air protection are recommended by Commander Sueter as the best agents for minimizing the effects of an explosion. He says:

"All compartments should be flooded, and subjected to a severer water pressure test before launching than that now customary. Each compartment should be tested like a tank to resist a water pressure varying from 40 pounds to 50 pounds on the square inch, without undue weeping of rivets. If the design allowed for spaces over the vital parts being filled with water or compressed air when in the vicinity of a coast where danger from submarines or torpedo-boats may be expected, the ship would then suffer the minimum damage by a successful torpedo attack. Ordinarily the compartments would be left empty. The ship would then have a higher freeboard and a higher gun platform for fighting in the open sea. A saving of weight might be obtained by doing away with ammunition passages, water-tight doors and fittings, substituting a tank system of cellular compartments, any one of which could be flooded easily and rapidly, or filled with compressed air by air compressors.

"The interior of a ship having such a tank system should be built in the form of an

internal ship, quite 10 to 15 feet from the outer skin, so that the inner skin could not more than slightly be pierced by an explosion. The amount of the water cushion or compressed air protection round the sides of a ship would, of course, have to be calculated so as to allow of a maximum space outside the engines and magazine.

"Battleships and cruisers should be modified and split up into cellular compartments. The center of gravity of each cellular space can be calculated from the designs, and if several compartments on one side of

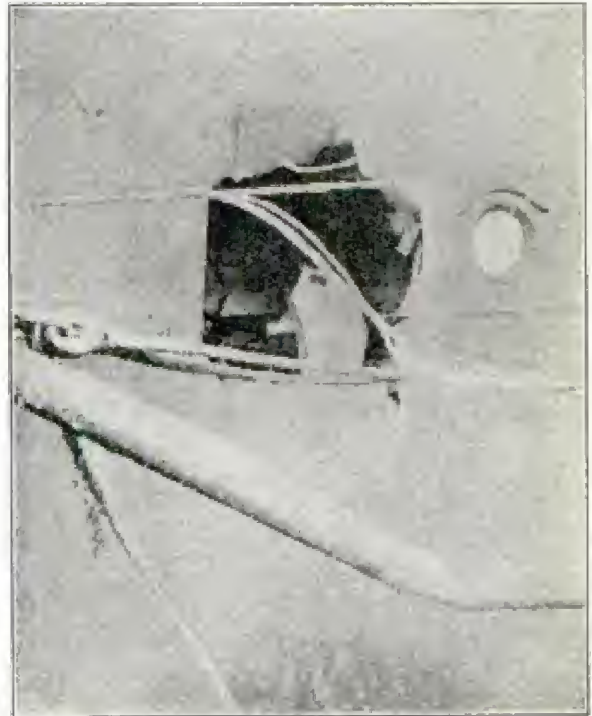

**Hole Made at Waterline by a Japanese Shell**

the ship were injured and filled with water, their opposite compensating compartments would be brought into use, and there would still be an ample margin of buoyancy. If large emergency Kingston doors were fitted so that abundant volumes of water could at once be let into special compartments to compensate, however large an injury were made, an even keel could be kept if the compensating compartments were at once flooded.

"No communication should be allowed from one compartment to another, except through manholes (not doors), which can be closed with great rapidity from below and on deck. If doors cannot be eliminated there should be as few as possible, and nearly all communication should be from the upper deck, for every door and hole in a water-tight bulkhead is a grave weakness. Fire mains, electric wires and steam pipes are indiscriminately run through the



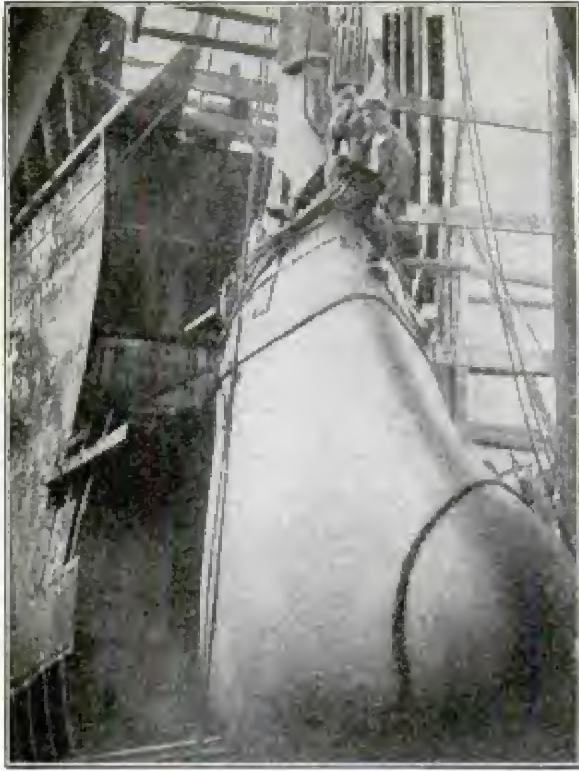

### The Formidable Ram-Stem

bulkheads, and are often not quite water-tight. All barbettes and similar parts of the ship should be made more water-tight than at present."

It is probable that in the future the ram-stem in battleships will be abolished. Naval authorities argue that were one of our high-speed modern war vessels, while going at a good rate, to ram another ship with intent to sink it, the attacking vessel would herself suffer terrible damage; that guns would be dismounted, rivets loosened and boilers would burst. In short, the vessel would be totally disabled.

The ram was first fitted to vessels of the "Hotspur" class, but since that time, there have been such rapid changes both in speed of warships and in projectiles that the conditions are now entirely different.

### BIG RAILWAY CAR-BUILDING PLANT FOR MONTREAL.

Montreal is to have a new car plant representing \$3,000,000 capital and with a capacity for turning out 25 wooden cars, 15 steel cars and 15 passenger coaches a day. The works will also have a capacity for steel underframes for 25 cars a day and 30 or 40 steel-truck frames. From 1,500 to 2,000 men will be employed, with a pay roll of from \$75,000 to \$125,000 per month, and between 500 and 600 tons of material will be handled per day.

### DEMAND FOR EXPERT MINING ENGINEERS.

Mining engineering offers an attractive field to the young engineer, not only in opportunities to rise in his profession, but in the financial returns. At the annual meeting of the South Staffordshire (England) Institute of Mining Engineers, the president, Prof. Redmayne, pronounced the problem of deep mining, one which will demand the increasing attention of the profession. He stated that tapered ropes are not necessary down to 5,000 feet; that compressed air can be used where electric coal cutters are dangerous, but the compressors may be operated by electric motors. That the difficult problems in deep mining are heat, ventilation and crush due to pressure. He said:

"I know of no other calling, unless it be that of a medical practitioner, which makes so many and great demands upon one's intelligence, physical endurance, and moral strength, as that of mining engineer; for, besides being an all-round miner, he has to have more than an elementary acquaintance of the allied sciences and their applications, and being in daily contact with large bodies of workmen, has to learn to feel for them while working with them. Indeed, he has to be possessed in no small degree of that estimable quality which we name tactfulness; and few men have to be more resourceful in dangerous emergencies."

### ELECTRIC RAILWAY POWER FROM GAS ENGINES.

A somewhat unique departure from established methods in electric traction has recently been undertaken at Warren, Pa. The Warren & Jamestown Street Railway Company is equipping an alternating current single-phase electric railway system to operate between Warren, Pa., and Jamestown, N. Y., for which power will be supplied by gas engines operating upon natural gas. The equipment now being constructed will include two gas engines of 500-horsepower each, direct connected to two 260 k. w. generators. Five transformer substations will receive the high tension current from the transmission line and reduce the voltage for use in single-phase motors. The company has operated a portion of its lines for three years with current generated by a gas engine.



### AUTOMATIC DANGER SIGNAL FOR BROKEN BRIDGES.

An automatic signal for broken bridges, which will display the danger sign at both sides of the structure and far enough away

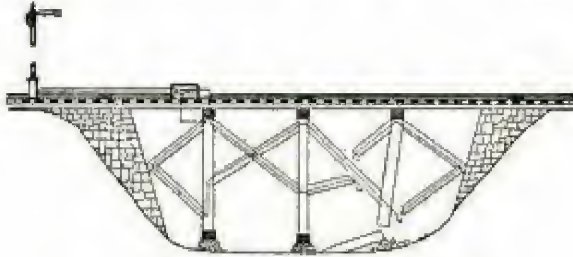

Danger Signal for Broken Bridges.

to enable even the fastest trains to stop in time is suggested in the *Locomotive Engineer*. The method proposed is a system of electric wires extending along all the principal girders and beams of the entire structure. If any one of these is harmed the wires would break and instantly cause electric danger signals to show at whatever distance and at such points as desired.

### HEAT FROM FIREPLACE WITHOUT LIGHT.

To warm a room from a fireplace and at the same time keep the room dark, have a tinner construct a black sheet-iron box or screen, as shown in the cut. The bottom

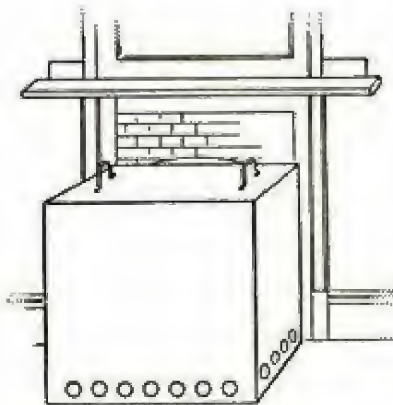

Heat From a Fireplace Without Light.

and side of the box next the fire should be left out. Punch holes around the bottom to admit air to the fire. Nearly as much heat will result, and the smoke and light of the fire will be shut in.

### COMBINED MUFFLER AND WHISTLE FOR GAS ENGINES.

A combined muffler and whistle for gas engines is being placed on the market. The head is not rigidly secured to the body, but is held in place by a stiff coiled spring. If an explosion occurs in the muffler the head will be forced out of place sufficiently to permit the excess pressure to escape without doing any damage, and will reseal itself. A chime whistle is placed in the head and sounded by the pressure of the



Combined Muffler and Whistle for Gas Engines.

exhaust, and by turning the head on its axis a sort of butterfly valve cut-out is opened. The device can easily be attached by anyone familiar with the use of gasoline motors.

### ELECTRIC MAIL WAGONS IN PARIS.

Many of the mail wagons in Paris are now electric-propelled vehicles, weighing 4,200 pounds, and carry a load of 1,100 pounds of mail. Storage batteries weighing



Electric Cars in Postal Service.

1,320 pounds furnish current sufficient to last for a 37-mile trip. The *Motor Age* says the new wagons carry twice as much mail as the former horse-drawn vehicles and travel much faster.



## HOW TO PRODUCE COLORED PHOTOGRAPHS OF FERN LEAVES.

A correspondent in the Photo Beacon gives the following details of how to arrange leaves and produce pictures of Nature's coloring: From my collection of leaves, I select those combining beauty of form with transparency, and arrange them in designs according to taste, fixing them with gum on very thin paper. When dry, I wash off with a small brush and cold water any gum that may appear on the surface. To give the paper a rich appearance and make it transparent, I coat the back of the design with a solution—castor oil, methylated spirit and sulphuric ether, in equal proportions. I then press the design between two pieces of blotting-paper. When thoroughly dry, I place it in a photographic printing frame (to which glass is fitted), with the leaves uppermost. On the leaves, I place a sheet of printing-out paper, with, of course, the sensitized side to the leaves, close the frame and expose to the light.

Leaves take two or three days to print unless the sun is strong. They should remain apparently overprinted. When I think the photograph of the design is ready, I take it out of the frame and put it in a bath of hypo for 10 or 15 minutes. This bath soon disposes of the overprinting to which I have referred. No toning is necessary, but after the hypo bath the photograph must be well washed in cold, running water for at least an hour. No camera is required. The first photo produced will be a negative. A positive may be had by using the negative in exactly the same way as the design was used.

## HOW TO MEND CRACKED NEGATIVES.

Cracks in negatives, says a writer in *Der Amateur Photograph*, in which the film has not been damaged, need not be repaired by floating off the film, but can be mended as follows: Over the glass side of the negative a mixture of one part of turpentine and one part of Canada balsam is poured so that it will penetrate into the crack. The surplus is removed by a rag dipped in benzine. In copying, the crack, it is said, will be absolutely invisible. The difficulty of handling such a negative may be overcome by binding it to another plate in lantern slide fashion.

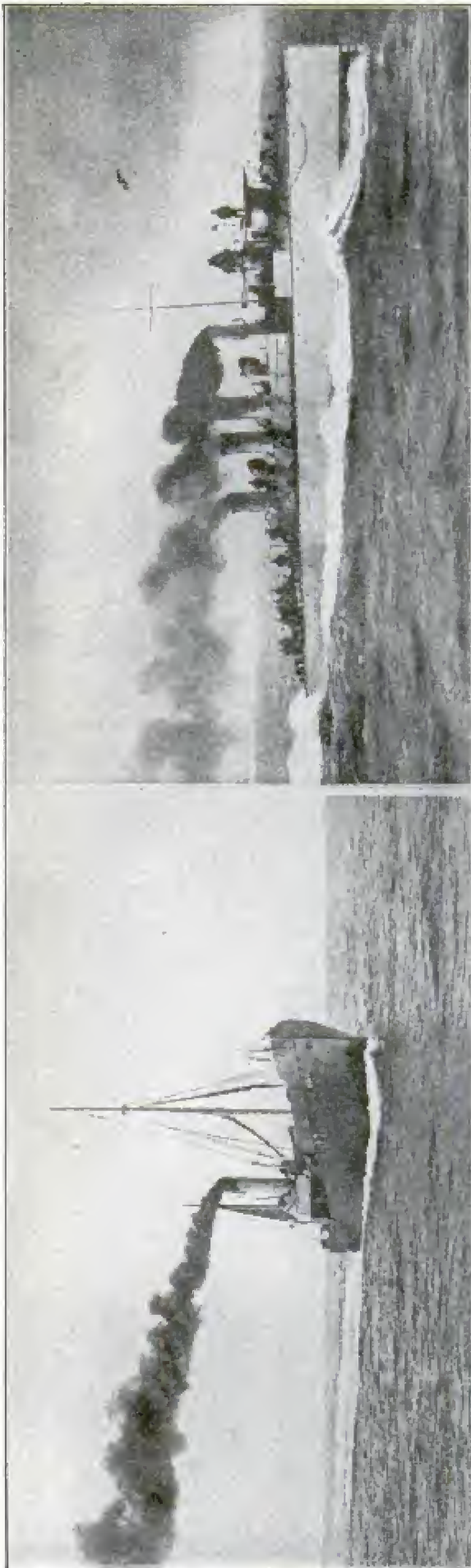

This is the North Sea Trawler which Looked to the Russians Like this Japanese Torpedo Boat.



## Mitchellite, the New Smokeless Explosive.

**Six Times as Strong as Dynamite, but Blasts Out Rock in Any Desired Shape--Safe to Handle--Freezes at 45° Below Zero--Produces No Gas.**

Experiments made recently with a new explosive known as "Mitchellite" indicate the discovery of a substance which is likely to revolutionize one of the most important branches of mechanics. The tests were made on November 24th and 25th at the Joliet quarries of the Western Stone company, under the auspices of the directors of a powder company, the owner of the new explosive, and the expert employed for such tests by the stone company. Results of the tests showed some interesting features connected with "Mitchellite."

A number of blasts were made with different sized charges of the new material and it was found to be possible to loosen the stone in any desired size of blocks according to the number and position of the holes drilled in the stone, the size and character of the cutting being completely controlled by the explosion according to the desire of the experimenters. This is said to be impossible with any other explosive hitherto invented. A tree three feet in diameter was blown out of the ground by the explosion of one half pound of the substance, leaving a hole twenty feet deep and twelve feet across where the tree had stood.

The explosion of "Mitchellite" produces no generation of noxious gases whatever and operators are thus enabled to enter mines or tunnels immediately after a blast has been fired. In using any other kind of explosive in a confined space it is found necessary to suspend operations after a blast for from twenty-five to thirty minutes in order to give the atmosphere a chance to clear.

Used in cartridges "Mitchellite" shows a maximum of penetrative power with a minimum of recoil. A steel bullet fired out of a rifle by means of the substance penetrated a steel rail one half inch in diameter; another was forced entirely through a tree three feet thick and eighteen inches into another placed next to it.

The new explosive resembles coral in appearance, being white and pink in color. It is considerably lighter than dynamite. In the crude state it appears in lumps but in use it is in granulated form somewhat coarser than granulated sugar. It can be fired only by an electric spark with a per-

cussion cap and is thus perfectly safe to handle. When ignited it burns slowly like red fire. It freezes at a temperature of 45 degrees below zero Fahrenheit. (Dynamite and nitro glycerine freeze at 40 degrees above zero Fahrenheit.) Its use, therefore, obviates the necessity and danger of thawing out the explosive in case of freezing. It can be exploded in water as well as dry.



**Holes in 1-2 inch Steel Plate, made by Bullets Fired by "Mitchellite"**

One half pound of the substance was found to do the work of three pounds of dynamite, showing that it is six times as strong as the latter explosive.

Owing to the destructive effect of the use of dynamite in macerating the underlying strata and thus rendering it useless for future blasting the stone company has abandoned its use, preferring ordinary gunpowder. This objection does not obtain in the use of "Mitchellite," the underlying strata being practically unaffected. At the conclusion of the experiments made at the quarry the company's expert stated that the tests were perfectly satisfactory and that, in his opinion, there was a fortune in the new explosive.

The substance is named after its inventor, a Mr. Mitchell. It was first produced about a year ago and is already on the market at a retail price of twelve cents a pound (four cents cheaper than dynamite.) Analysis failed to fully determine the composition of the material and the secret remains with the inventor.



## Novel Double Deck Street Car.

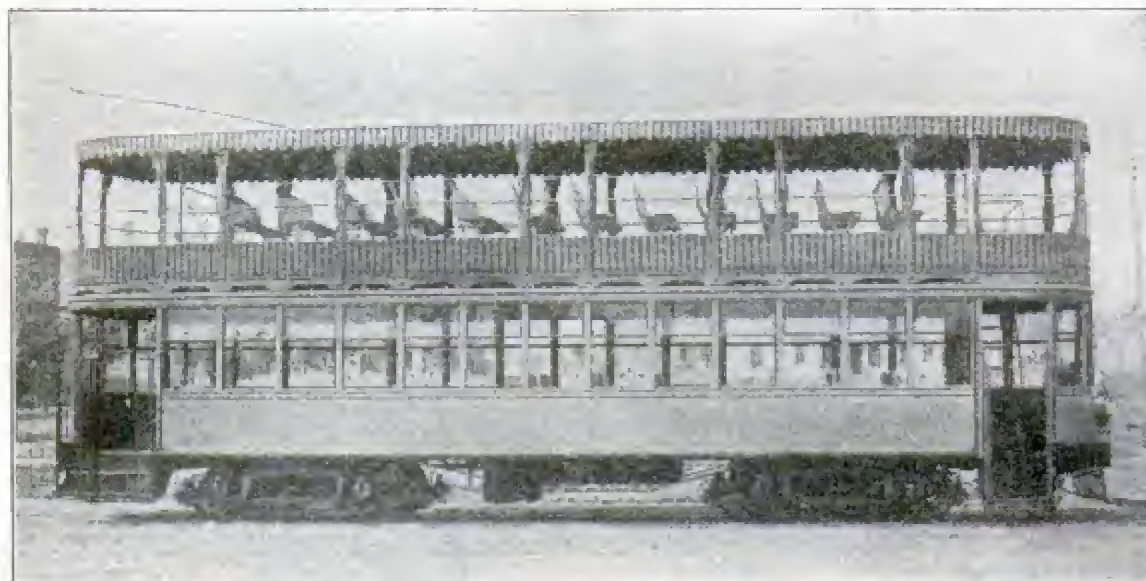

**This Car Will Seat 48 People on the Upper Deck.**

An open summer car, placed on top of a standard closed street car, is the latest type of double-deckers. Such cars are in use in Minneapolis. The open car portion is thus really a street car without wheels. The upper deck is reached by spiral stairways placed at each end of the closed car. In the winter the upper, or open car, is re-

moved and the ordinary closed car is left. The Street Railway Journal says:

"This car will seat 48 people on the upper deck, in addition to the capacity below of 51 seated and 65 standing. This is a remarkable achievement for a 45-foot car. The entire weight of the car and equipment is only about 26 tons.

### SELLING SUBMARINES TO BELLIGERENTS.

It is common knowledge that several private shipyards in this country have accepted and fulfilled large contracts for submarine boats for both Japan and Russia. This has brought up the question as to whether such contracts are a breach of neutrality on the part of the government of the United States. In this regard a reliable authority on international law says:

"It is fully recognized that a vessel completely armed and in every respect fitted, the moment it receives its crew, to act as a man-of-war, is a proper subject of commerce. There is nothing to prevent its neutral possessor from selling it and undertaking to deliver it in the neutral port or in that of the purchaser, subject to the right of the belligerent to seize it as contraband if he meets it on the high seas or within his enemy's waters. 'There is nothing,' says Mr. Justice Story, delivering the opinion of the United States Supreme Court in the case of *Santissima Trinidad*, 'in the

law of nations that forbids our citizens from sending armed vessels as well as munitions of war to foreign ports for sale. It is a commercial adventure which no nation is bound to prohibit.' If the neutral may sell his vessel when built, he may build it to order, and it must be permissible, as between the belligerent and the neutral state, to give the order which it is permissible to execute. It would appear, therefore, arguing from general principles alone, that a vessel of war may be built, armed and furnished with a minimum navigating crew, and that in this state, provided it has not received a commission, it may clear from a neutral harbor on a confessed voyage to a belligerent port without any infraction of neutrality having been committed."

This is the view repeated in sense by several other authorities. Since the Civil War armed ships, constructed in this country and supplied to foreign countries while in a state of belligerency, have been a common incident of our industrial condition and one to which no exception has been officially taken by any country.



## Where Millions of Dollars are Made.



**The Great Press Room at the Bureau of Engraving and Printing, Washington, D. C.**

The heavy silver and gleaming gold annually converted into the coin of the realm at the government mints, represent but a fraction of the total value in currency, revenue and postage stamps, notes, bonds and other securities which during the year go through the presses of that leviathan institution, the government printing office. Into the numerous buildings, warehouses and offices required to accommodate the Bureau of Printing and Engraving every week-day morning troop thousands of employes, men and women, young, middle-aged, old and aged, people of every degree, character and type up to the number of 3,691. Here they grind out the reports of committees, executives, departments, consuls, in short, all the credentials a great nation presents to the people whose money it expends. Here sometimes, when the stress of national affairs demands it, will be found another gigantic force toiling away the still hours of the night.

Last year there was appropriated for the use of the Bureau, \$6,000,000, and now the

government is preparing to expend a quarter of a million in enlarging an institution that already includes large stables where are carefully sheltered and cared for the horses used in connection with the printing establishment; printing papers warehouse, whence are issued daily thousands of reams of paper and where is stored with jealous care the paper upon which United States currency is printed and no paper is given out of this warehouse without a certified order; binders' warehouse, where are stored the supplies required in the bindery; a huge foundry, where is plated hundreds of thousands of quarto and octavo pages, and huge vaults for the storing of such plates as are for preservation. These usually include reports of scientific and educational nature, such reports as are apt to be called for a second time. Many plates are remelted after the required number of copies have been printed from them. The vaults have a capacity for upwards of 4,000,000 plates.

Of all the people employed in the government printing offices 2,920 are at work





**Counting Currency.**

making United States notes, bonds, internal revenue stamps, postage stamps, custom stamps, etc. Naturally the product of such employes is watched and safeguarded by every means possible. All the printing is done on old-fashioned hand presses, each of which requires two operatives. Currency is printed on sheets each of which contain four or five bills, while postage stamps are struck off in sheets of four hundred. The Bureau has many unique machines that almost think. One of these is the wonderful geometrical lathe which makes the intricate designs on the back of bank notes and another is a numbering machine which auto-



**Engraving Postage Stamps.**

matically numbers currency from 1 to 1,000,000,000. The operations of the Bureau are surrounded with every precaution and the newly made money is counted fifty-four times during its transit through the institution.

In 1902 new designs for both the backs and faces for notes of the denominations of five, ten, fifteen, twenty, fifty and one hundred were engraved and this required that a gigantic force be kept busy day and night. On regular time \$3,704,491.65 are paid out annually in salaries to the printing office employes. Much of the printed matter is now regarded as so much unnecessary expense and, probably, its volume will soon be greatly reduced.

A large reserve of United States notes and silver certificates is always kept in the Treasury vaults. Officials are always glad to see this reserve increase, as it gives the certificates time to become well seasoned and adds to their appearance and wearing qualities.

---

#### HEAT WITHOUT FUEL.

A colored man of St. Joseph, Mo., has invented an apparatus which he believes will in time do away with combustion for all purposes, except, possibly, foundry furnaces or similar cases where great heat is required.

Friction is the agency which the inventor proposes to use for producing heat and he has built a working model about three feet in length to demonstrate his idea. It consists of a steel tube surrounded by a jacket and inside of the tube a wooden roller cut into four triangular sections and arranged about a steel shaft. The wooden roller is five inches in diameter and the inside of the tube in which it runs is six inches in diameter. The water chamber outside of the tube is ten inches in diameter, leaving four inches in the water chamber.

---

#### WATCH INSPECTION FOR BIG RAILWAY SYSTEMS.

The duties of a traveling watch inspector for a big railway system are much more arduous than one might imagine. One system pays \$18,000 per year for this purpose only. It takes the assistant inspector two years to visit all the inspection points on the lines and each test of a watch lasts 72 hours. If it varies six seconds in that time, it is rejected.



**PRIVATE ELECTRIC FIRE APPARATUS.**

Many property owners in the business districts of large cities are taking warning from the Baltimore and the Toronto fires and installing private fire protection apparatus. The Baltimore Fire Department admits that many buildings on the immediate margin of the devastated tract were saved only by the effective work of private apparatus. These buildings were supplied

apparatus in Baltimore were valued at \$5,000,000, and at Toronto the saving from private protection was similar in extent.

The advantage is that the apparatus is on the ground in position and ready for action, whereas a fire is usually well under way before the city fire companies can arrive, arrange their hose lines and make necessary couplings and connections. A drenching of the entire building is then often required, while a comparatively small amount

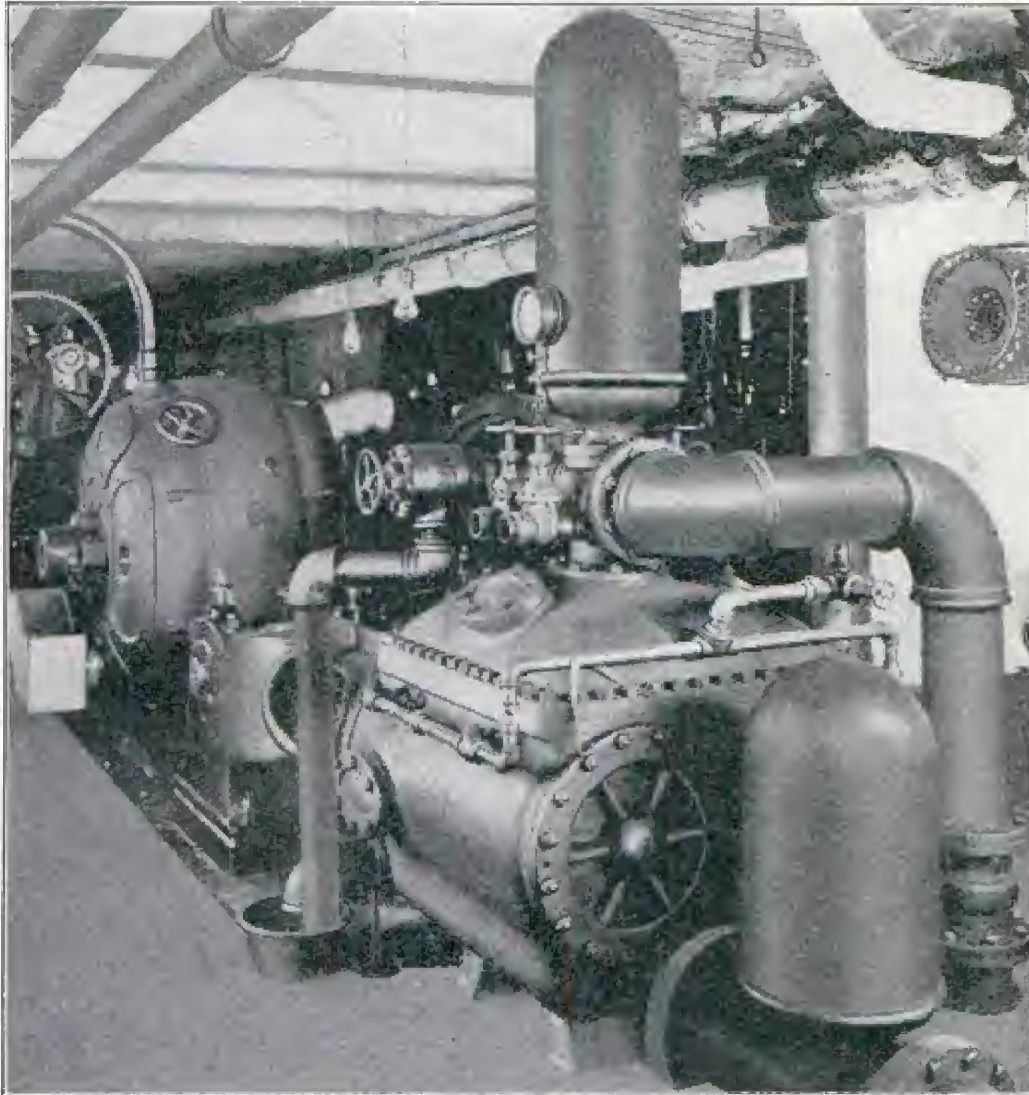

Electric Fire Protection Apparatus—Always Ready.

with either stand pipes or pumps connected with wet-pipe interior sprinklers and dry-pipe sprinklers for protection from outside fires, storage tanks holding from 1,500 to 15,000 gallons being placed on the roofs. Besides saving the buildings in which they were located these equipments stopped the advance of the fire, and undoubtedly many more buildings would have been destroyed in the absence of their efficient service. The buildings and contents protected by private

of water would have put out the fire in the first place.

A very interesting installation of private fire protection apparatus was recently made in a big Chicago department store. The apparatus is operated by electric power which is always available in a city and causes the least delay possible. The outfit consists of a duplex pump connected by single-reduction gearing to a water-proof electric motor. The pump cylinders are 8 inches in diameter



by 12 inches stroke, having a theoretical capacity of 700 gallons per minute at 600 R. P. M. against 140 pounds water pressure. The illustration gives a good general idea of the pump, showing the special attachments and the large pressure and vacuum chambers required by insurance companies. The pump is thoroughly rust-proof in all moving or wearing parts, insuring prompt and smooth running when occasion arises. The motor is shunt wound for 220 R. P. M. at 230 volts and is enclosed, all connections being carried through pipes screwed into the frame, so that the device may be flooded without affecting its action. The fields and armature coils are cooled by fans on the armature shaft, the ventilator intake and outlet being visible in the photograph.

With such an apparatus hardly an emergency could arise in which it could not be relied upon. The use of electric power is more economical than steam in that there is no stand-by or maintenance expense.

#### FLOATING MOTOR HOUSEBOAT ON THE MISSISSIPPI.

Among all the queer craft that have navigated the Mississippi in the vicinity of St. Louis this year, none has attracted more attention than a houseboat which appears to be fitted with a huge paddle wheel almost as large again as the boat, and which is, in fact, a paddle wheel and motor drum combined.

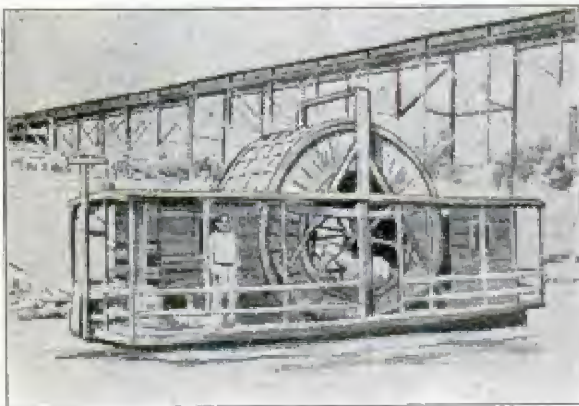

"The Great Wheel is Almost as Large Again as the Boat"

This wheel is 12 feet in diameter, 5½ feet wide and its outer circumference is covered in checkerboard effect with buckets, 3 inches deep, four rows of 32 buckets each extending entirely around the wheel. The boat and the wheel each floats on its own keel. The wheel rests in the water at the center of a catamaran boat platform.

The paddle-wheel-motor-drum is open in

the center of each side and in one side has a door through which "Nig," the motor, is admitted. "Nig" is a pony who treads the great wheel and causes it to revolve, thus propelling the boat. He is hitched in a pair of shafts, and climbs the wheel as a squirrel does in a revolving cage.

"Nig" is considered a character among Mississippi rivermen, who all know him. The inventor of the houseboat, Charles Martell, a French Canadian carpenter, believes old wheels of river boats can be utilized in this manner and that such craft will some day cause the Mississippi to teem again with traffic.

#### AUTOMATIC SCULPTORS.

A Berlin inventor has succeeded in perfecting a new automatic sculptor which copies models in every particular just like the originals. This is the second invention of this nature, but the first works horizontally while this works vertically. The operation of the machine is as follows: The



Statue-Copying Machine in Operation.

operator swings down the delicately-poised frame on to the dummy; the pointer is hovering over the model to be copied, and instantly the revolving drills cut into the rough blocks of wood or stone, shaping them speedily as the point is moved to and fro. According to the capacity of the machine from two to eight copies may be made of any model in relief or intaglio. The largest machine can do the work of twenty-six highly-paid craftsmen.



### ASPHALT PAVING HEATS HORSES' SHOES.

A horse shod with metal shoes should not be driven rapidly on an asphalt pavement. The heat produced will not only be painful to the horse, but may seriously injure him. One of our subscribers recently called to relate his experience in driving on asphalt pavement. He was riding horseback in company with a friend, when the two engaged in a friendly race. After they had gone about a mile, his friend's horse threw a shoe. Going back to the place the rider dismounted and picked up the shoe, which was so hot it not only severely blistered his hand, but did not cool so it could be taken up for several minutes. At each step the horse slips a little, and this constant rapid sliding of the metal shoe, under weight, upon the sand contained in the pavement, generated a high degree of heat.

### TRANSPORTING THE WOUNDED ON GERMAN WAR VESSELS.

The German navy has adopted a method of transferring sick or wounded men from one vessel to another or sending them ashore, which is claimed to be very comfortable for the patient and a most con-



Sending the Patient up a Steel Chute.



Lacing the Patient in the Canvas Shroud.

venient way of handling helpless bodies. The device is at least unique.

The sick man is first laced up in a stout canvas shroud and, after this operation, looks as though he might have been removed from some ancient Egyptian tomb. The back is stiffened so there is no possibility of the patient's bending, and the sides are provided with strong rope handles. The upper rings of the canvas casing are then bent on to the raising tackle, and the sick man is sent up a steel chute in the twinkling of an eye.

### INDEX TO 1904.

The index to Vol. VI., January to December inclusive, 1904, is now ready and will be mailed free on request to any of our readers who desire to bind their volume.

We have a few remaining bound volumes of 1904, price, express paid, \$3.

Indian kerosene oil is not of as good quality as imported oil, but, nevertheless, the importation during the fiscal year ended March 31, 1904, fell off 10,000,000 gallons. Indian oil fields have been developed rapidly and the oil is so cheap that it has secured a ready market.



## NEW FIRE BOAT FOR MANCHESTER SHIP CANAL.

A new fire boat, the "Firefly," has been built for the Manchester, England, Ship Canal. It is the largest ever built in England, and cost \$50,000. It is 90 feet long



The "Firefly," Fire and Salvage Steamer for Use on the Manchester Ship Canal.

by 23 feet beam, but only draws 3 feet; speed 8 knots; propellers, twin screw type. Two pumps have a capacity of 2,000 gallons, and two salvage pumps, centrifugal type, deliver 2,500 gallons per minute. Two 3½-inch streams were thrown to a height of 100 feet.

## THE HYDROVALVE, A NEW FORM OF WATER WHEEL.

A new water wheel of a construction combining features of both the overshot wheel and the turbine has recently been patented in several countries. The important feature of this new wheel, which is called the

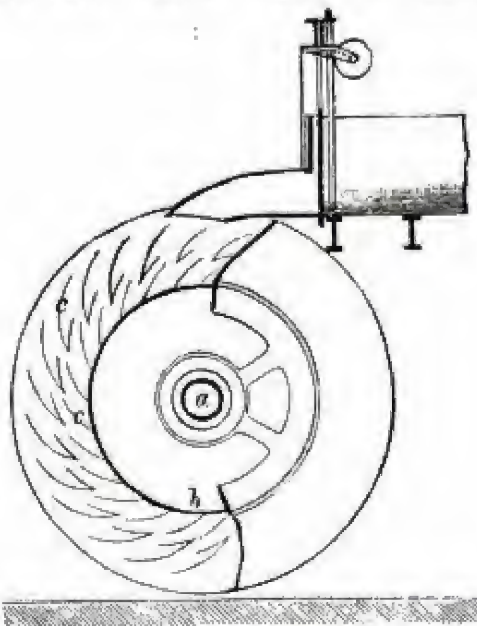

Diagram of Hydrovalve.

hydrovalve, is the peculiar construction of the buckets which carry the water to the point of exit, where a reactionary effect which utilizes all the remaining force of the water takes place as it leaves the

buckets, so that the water in the tail is almost quiet instead of, as with many older types of wheels and with turbines, whirling and swirling, full of unused energy.

The construction of the hydrovalve is shown in the sketch. It consists of a horizontal axis, a, a closed shrouding, b, and a partially closed paddle box, thus forming a circular channel bent around a central point opening out. The paddles and cells, c, within this circular channel are of peculiar construction. There are two rows of buckets, the first of which form cells with the shrouding itself, and the second row being cells of which the inner rims are lower than the outer ones, the walls of the inside circle of buckets forming outlets for this second row. When a pair of these upper cells are filled the water flows over inside the wheel to the next pair of cells and so on through all the pairs of cells in turn to the point of exit. This loads the rim of the wheel to the full half of its periphery and gives a very great starting power. The reactionary effect at the exit is caused by the water passing from the inside over the outer buckets to escape.

The wheel in the sketch is drawn to a scale of 1:40 and is adapted to a fall of 7 feet 2½ inches with a flow of 122,044 cubic inches per second. The dimensions of this wheel are as follows: diameter, 67 inches; depth, 19½ inches; width, 9 feet 10 inches. The wheel develops 54 effective horsepower.

## FIRST GASOLINE ROAD ROLLER IN ENGLAND.

The illustration shows the first gasoline road roller which was recently built in England. The machine weighs 16 tons, has a 25-horsepower engine, which consumes 8 gallons per day. The rear wheels are the drivers, and reverse is secured through a double friction clutch. The cooling water is carried in the lower tank shown, and circulation effected by a pump.



The First Gasoline Road Roller



**MOTOR BOATS FOR OCEAN RACES.**

Motor boats for crossing the ocean in the contemplated competition should be nearer 400 feet than 40 feet, declares Mr. W. E. H. Humphries, an Englishman and a practical motorist of wide experience. He says:

"The conditions of the race are that the boats shall be able to travel at a speed of at least 15 knots, shall carry all their own fuel, lubricating oil, and spare parts, and shall start with at least six persons on

**HOW MIRRORS ARE MADE.****Silver has Taken the Place of Mercury**

The making of modern mirrors consists first in ridding the glass to be used of all defects and then silvering. If the mirror is to be beveled, additional operations of beveling and preparing the glass precede the silvering. Nowadays silver has, to quite an extent, taken the place of mercury in this industry.

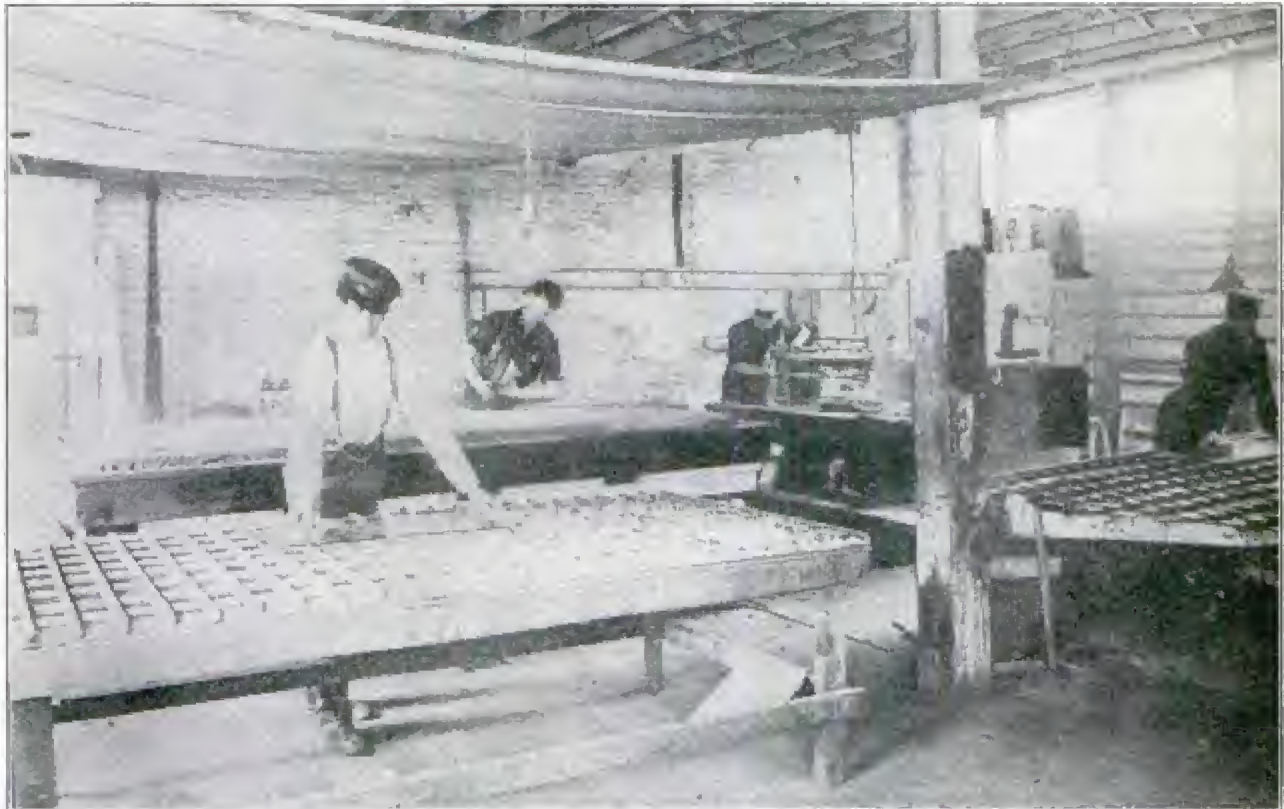
**Where the Silvering is Done**

board. This rules out of the contest all small racing craft. The normal consumption of a petrol engine may be regarded as 1 pint per horsepower per hour, which means that for every 100 horsepower of the engine there is consumed approximately 300 gallons per day. With a 15-knot boat the passage from Havre to New York might be expected to occupy from twelve to fifteen days. Hence for every 100 horsepower of the engine it will be necessary to carry 4,500 gallons of fuel, occupying approximately 723 cubic feet of space and weighing 15 tons, or more, if fuels heavier and less efficient than petrol be employed. To complete the absurdity, the Calais-Dover racer would require, to enable it to cross the Atlantic, a bulk of petrol of greater weight and greater displacement than the boat itself.

In selecting glass suitable for mirrors, the experienced workman, by placing a piece of black cloth behind the glass, and looking through at an angle, quickly discovers all defects. Even the scratches and stains must be removed in the making of a really good mirror. Scratches are removed by holding the glass upon an upright buffing wheel covered with felt. The stains are removed by a device known as a "blocking machine." Unless it is to be beveled a glass free from stains and scratches is ready for silvering.

For beveled mirrors, plate glass is used. The bevel is obtained by holding the glass against a horizontal roughing wheel, sand and water also playing an important part in the operation. The bevel, like the surface, must also be polished. An emery wheel is used to remove the sand and clean the surface. Then after being held against a





Buffing the Beveled Glass.

horizontal grindstone, a polishing wheel with pumice stone is used. To brighten the glass, a buffing wheel with rouge upon it is employed.

At least three things are claimed for silver

in place of mercury in the making of mirrors. In the first place, that it reflects more light; secondly, that mirrors can be turned out in less time, and, in the third place, that the work is made more healthy for the employes. In silvering a modern mirror, after the glass has been freed from defects and sufficiently polished and washed, a preparation that will hold the silver is poured on. Next the glass is removed to a perfectly smooth table which is heated by steam. As the silver solution is poured upon this table a goodly per cent of it at once begins to adhere, the remainder later being drained off. Over the back, shellac is then applied to keep out the moisture.

In the earlier days of mirror-making, sheets of tin foil were first placed upon the surface of the glass and pressed closely to it, after which it was covered with quicksilver, the quicksilver at once forming an amalgam with the tin. Various methods are employed in making mirrors where quicksilver is used.

#### GAIN IN QUICKSILVER PRODUCTION IN 1903.

An official report says that the production of quicksilver in the United States during 1903 amounted to 35,620 flasks of 76½ pounds each, valued at \$1,544,934, an increase in quantity of 1,329 flasks and in value of \$77,986 over 1902. California and Texas mines are the largest producers of the metal.



Holding the Glass Upon the Horizontal Smoothing Wheels.



## Low Tide in the Harbor of Panama.



Courtesy of Smithsonian Institution.

**Scene at Low Tide in the Harbor of Panama.**

In the illustration is shown a most unusual scene characteristic of the harbor of Panama at low tide. Across the little isthmus on the Atlantic side at Colon the range of tide is only one foot, but on the Pacific side it is 20 feet.

During low tide the ships rest on the beach where the loading and unloading is

carried on quite as though the place were never covered with deep water. Wagons and horses, native laborers, sailors, boxes and casks crowd the shores. High tide finds them all removed, and the crews and cargoes aboard the vessels ready to be floated again upon the accommodating deep.

### **NAPHTHALINE AS A SUBSTITUTE FOR GASOLINE.**

In countries not so rich as ours in natural supplies of petroleum, a great deal of experimenting is done in an effort to find a substitute for gasoline as fuel in internal combustion motors. As a result, in France automobiles using alcohol as fuel are in competition with those using gasoline and in England, where alcohol is heavily taxed, there is one car in which kerosene has been successfully substituted.

Two French engineers, however, have produced the best substitute yet tried, having perfected a method of using solid fuel—naphthaline. In this system a reservoir contains the fuel which is liquefied and sprayed

into the engine cylinder and carries with it enough air to insure proper combustion. The one drawback to this system is that to secure the high temperature required for the vaporization of the solid fuel the preliminary use of gasoline is involved.

Naphthaline is an inexpensive coal tar by-product and is familiar to every one in the form of moth balls.

The ordinary watch cannot be used on submarine boats, but a special watch, the construction of which conforms with the conditions within the underwater craft, is necessary. These watches cost from \$75 to \$100. None is manufactured in the United States as yet for watchmakers are loth to invest for the first order of them.



**CONSTRUCTION OF A GAS TURBINE—  
ENGLISH INSTITUTE PRONOUNCES  
UNFAVORABLY.**

The success of the steam turbine is stimulating builders of gas engines to perfect a gas turbine. Such a machine in small powers would be welcomed by automobile and launch owners. A 200-horsepower gas turbine is being built by the Stolze Gasturbine Company, of Berlin-Charlottenburg, Germany, to which we are indebted for the particulars given below:

In this engine atmospheric air is compressed to a moderate tension, say  $1\frac{1}{2}$  atmos. above atmospheric pressure, and heated afterwards so as to assume a 2 or  $2\frac{1}{2}$  fold volume at the same tension, after which the air is allowed to expand down again to atmospheric pressure. The excess of work performed over the absorbed energy is thus due to the increase in volume resulting from the heating.

Two sets of turbines of different design are mounted on a common axle. One of these serves as air compressor, while the other drives the shaft by means of the heated air. Either set consists of several rows of guiding vanes, fitted to the engine casing and of several rows of running vanes of a corresponding design, being fitted to a common rotating cone which turns round along with the shaft. Now, one of these turbine systems sucks in the fresh air, compressing it to a given tension through a preheater (heated with exhaust gases) and driving the greater part of it into a chamber lined with fireproof material. The smaller part is conveyed beneath the grate of a producer where it serves to gasify a convenient fuel. The gas thus formed penetrates into the chamber alluded to, to be burnt there by the compressed air in suitable burners to carbonic acid and water vapor, while evolving large amounts of heat. These gases next penetrate into the second turbine system, where they are allowed to expand in traversing the various steps, thus yielding useful work.

The process is thus analogous to the cycle performed in all combustion engines, consisting of a suction of air, that is followed by the compression of the same, the mixing with fuel, combustion, expansion and subsequent discharge. A distinguishing feature is, however, that the mixing takes place after compression and the combustion at constant pressure.

On the other hand the Institute of Mechanical Engineers (England), at its October session, expressed its belief that "a gas turbine is, for the time being, at all events, mechanically impossible."

The Engineer, London, says editorially:

"There is not in existence, and possibly never can be, a commercial gas turbine; and the main value of the discussion lies in its power to serve as a guide, and prevent the waste of money on impossible combinations of mechanism. The paramount difficulty lies in the circumstance that the moving gas has to be admitted to the turbine at a temperature which would at once raise the blades to a bright red heat. As the gas must contain free oxygen the steel blades would be "burned" in a few hours. It is true that suggestions were made for the cooling of the blades by water, but we must take account with centrifugal force; and it is very far from easy to see how water could be used without upsetting the very delicate balance of the wheel. So great is the temperature difficulty that we might almost leave the discussion of the questions raised here; but even about impossible engines there are points worth discussing, and it is indisputable that much ingenuity has been manifested by Mr. Parsons and others in trying to devise methods of keeping the wheels cool. For example, the hot gas jet acts at one diameter of the wheel while a cold-water jet is projected on it at another.

"The first condition of success is, of course, that gas shall be available to work the turbine. Now, in a reciprocating engine the gas is fired in a cylinder, behind a piston, and produces driving pressure. Nothing of this kind can take place in the turbine. The only conceivable turbine, we think, driven by gas must be one working on the De Laval principle, because in it a wheel might run red hot, being as it is, so to speak, free 'in the open'; but the material has yet to be found which would endure the centrifugal effort at the temperature. But let it be supposed that all mechanical difficulties were overcome, and that a fire-clay turbine were possible, actuated by gas in the condition of a white-hot flame. What would be gained, and how much better would the new machine be than the reciprocating gas engine or the steam turbine?"

◆◆◆◆◆

Last year the production of asbestos in the United States was 874 tons, compared with 1,005 tons in 1902.



## Conning Tower--Brain of the Battleship.

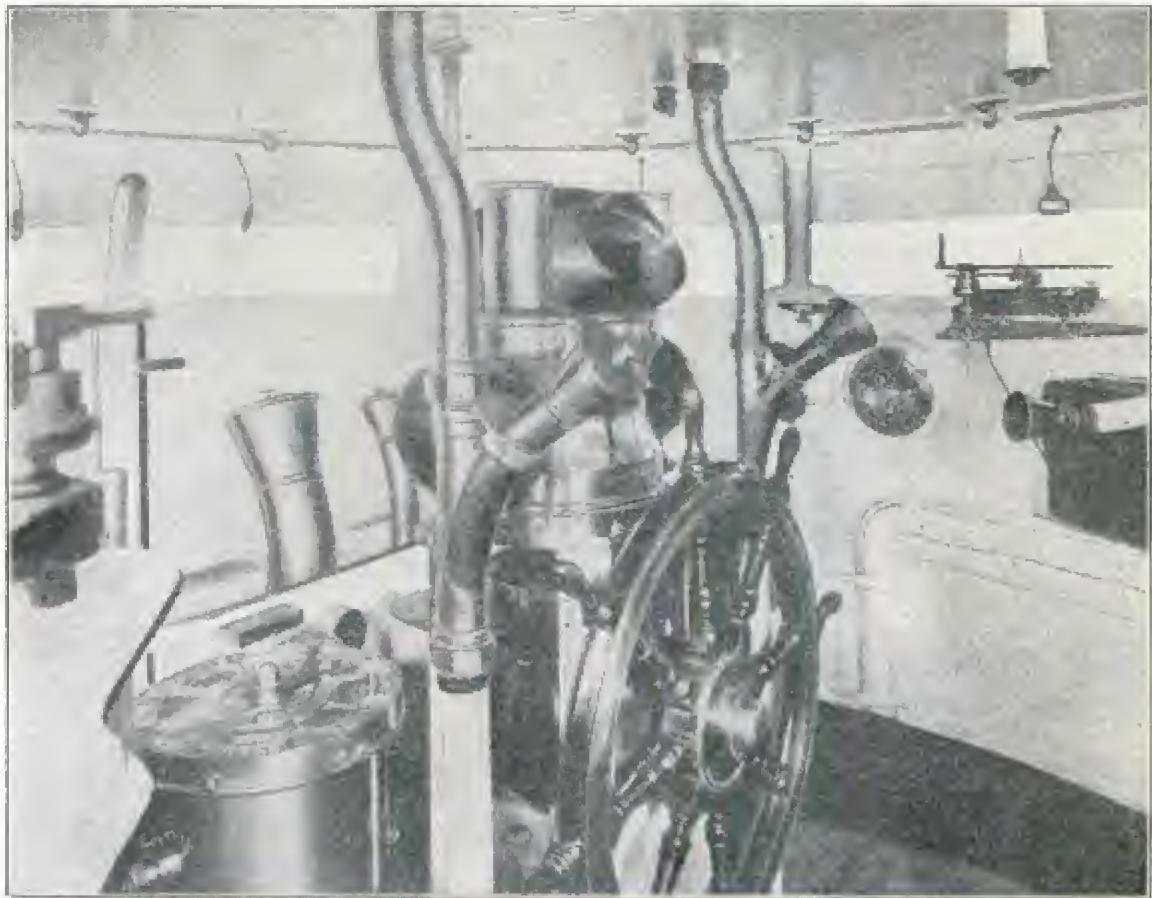

**The Conning Tower is the Brain of the Battleship. From this center of intense activity communication leads to every working member of the ship. The engines, rudder, turrets, pumps, guns, torpedoes, signals--all these things are directed from the Conning Tower in time of action. Every part of the ship is made respondent to the touch of a button, the movement of a small lever, or verbal instruction through a perfect system of telephone connection.**

## The "Autopyrophon," a New Automatic Fire Alarm.

The "autopyrophon" is a small glass tube bent in the shape of a capital U, one-half of which is filled with mercury and the other with some highly volatile liquid, sulphuric ether, for instance. The ends of the tube are closed and one of the upper parts is surrounded by a cover of some non-heat conducting material; both parts are fitted with an electric wire melted into the glass.

This little apparatus, which measures 3.94 inches in height, 2.76 inches in width, and .78 inches in depth, is placed at any convenient point in a room. If the temperature of the room rises evenly the mercury in the tube stands at equal heights in both ends and the apparatus is not affected, but should a fire break out and the tempera-

ture in the room be suddenly raised the ether above the mercury in the glass tube, which is unprotected, evaporates, the pressure of the generated vapors causes the mercury to sink in the tube and rise in the other part completing the electric circuit and electric alarms at any and as many points as desired are set in motion. The apparatus acts for an indefinite length of time and it is not necessary to renew the substances.

W. F. Wright, United States Consul-General at Munich, Germany, who reports this invention, was present at a demonstration in which a fire from a small pile of shavings in an ordinary-sized room acted on the apparatus in eight seconds.



## BORING HOLES IN LOG WATER MAINS.

### An Eye Witness Tells How It Was Done a Generation Ago.

In the December, 1904, issue of *Popular Mechanics* appeared a description and illustration of an old log water main used in New York City 107 years ago and recently unearthed there. Many were the surmises as to how the hole through the center of the large log had been bored. W. E. Dale, of Atlanta, Ga., whose father had charge of the plant for boring holes in the logs used in the first waterworks system of Augusta, Ga., sends us some very interesting information on this point.

Boring the holes was accomplished in a lathe-like machine in which the log was made to revolve instead of the boring tool. This machine was in the shape of a half cylinder, tapering to and having a gimlet point at its axis on one end. At the other end a yoke terminated in a shank that bolted on to the tool rod. The boring tool was some 10 or 12 in. long and from 3 to 4 in. in diameter. A cutting edge extended from the base of the gimlet point the entire length of the tool, against which the wood revolved and was cut away and smoothed.

Two double flanged, 2-sectioned cast-iron pulleys, with openings in the hub large enough to girdle the log, rested on a casting having a half-circle concavity with same radius as the pulley face and same width as the face; while the flanges, one of which was toothed, prevented the pulleys from getting out of place.

To operate, the half of each pulley was removed, leaving one-half each on the bed casting. A log was then rolled into them and the other halves put on and bolted together. The log was then centered and secured by wedging inside the hubs; a pinion, working the toothed flange already mentioned, imparted motion to the log. The rear end of the tool or carrier-rod was fastened to a movable frame working on guide rails set so as to guide the tool along the axis of the revolving log.

The operator would first start the tool in while standing near the end of the log, so as to have it enter at the axis, he would then go back and push the tool through by shoving on the frame running on the guide rails.

The manner of coupling the wooden pipes together when putting them down was very simple and effectual. The couplings were

of cast iron, some 14 to 16 in. in length, of same calibre as the log pipe, about  $\frac{1}{4}$  in. thick at each end and gradually increasing in thickness from each end to the center, where they were about 1 in. thick and reinforced by a bead.

The logs had been counter-bored for a short distance at each end so as to compensate for the thickness of the cast-iron coupling. In coupling together the last log put down would be forced by levers or jackscrews against the coupling until it had become wedged sufficiently to form a water-tight joint.

The hydrants were formed by cutting off a piece of the bored log long enough to come 2 or 3 ft. above ground, its lower end connecting with a tee coupling; top end plugged; a hole bored into the center and a spigot driven in.

The pipes were all made from soft yellow pine, 12 to 16 in. diameter, and the springs from which the water came were about three miles from farthest end of the system.

The logs were not peeled or otherwise prepared, except as mentioned, before putting down. This system was in use as late as the '70's as an auxiliary to the more modern system.

---

## MULTIPLYING WATER POWER.

The annexed sketch shows how a German inventor proposes to make the most possible use of flowing water. The plan consists in making the stream operate a series of undershot wheels simultaneously. As these are coupled together, the total power can be collected and transmitted to a shaft or other device.

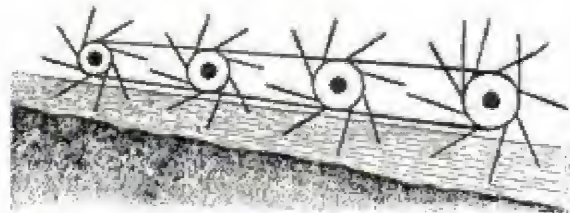

**Multiplies Water Power**

The power of the waterfall multiplied into the number of wheels will be that which drives the machinery. In the sketch the wheels are connected together by means of a chain or belting, and one of them transmits the power to a shaft furnished with a flywheel.



## SHOP NOTES

### PROPER METHOD OF USING SANDPAPER.

Of a piece of mahogany or clean pine about  $5\frac{1}{4} \times 3 \times 1$  inch make a rubber shaped



Fig. 1

as in Fig. 1 and glue a piece of sheet cork on the face of the rubber. Fold into three a piece of sandpaper 6 inches wide and 10 inches long and place the face of the rubber on the middle division, the sand side of the paper being downwards. The rubber should be grasped firmly, the ends of the sandpaper being held on its back and sides, as in Fig. 2, and then

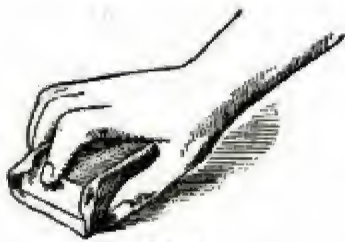

Fig. 2

the work may proceed. This method is recommended by Fred T. Hodgson in his New Hardwood Finishing.

Another method of making the rubber block

is by glueing a piece of rubber belting to a piece of basswood, or a solid rubber about one inch thick may be used.

### SOME GOOD PAINTS FOR STACKS AND BOILER FRONTS.

A good paint for this purpose is asphaltum cut down with turpentine to the right consistency; coal tar mixed with graphite and thinned with turpentine is good, also.

Steam pipe used for heating, says a correspondent of the Engineer, should not be painted, but can be given a thin coat of lampblack and linseed oil, which will greatly improve its looks.

### A SIMPLE FIRE EXTINGUISHER.

A fire extinguisher easily made and ready at all times for instant use consists of a gallon of water to which is added three pounds of salt and one and one-half pounds of sal ammoniac. Bottle this liquid and when fire breaks out pour it on.

### A HANDY CONCRETE FORMULA.

There are a great many formulas and a great many estimates for the cost of concrete, and here is another. A gentleman, who has had some experience, says that good concrete can be laid for about \$2.00 to \$2.25 per yard. Cellar floors and sidewalk can be laid down, furnishing everything for 12 to 14 cents per square foot super. Foundation work: One part of cement, three parts of plain sharp sand, six parts stone or broken brick so as to pass a 2-in. ring, properly moistened will make a good strong foundation.

### THE BEST METHOD OF FASTENING GUY LOGS.

In setting poles, says the American Telephone Journal, guy logs should be placed so as to offer the greatest resistance to the strain. The illustration shows the best

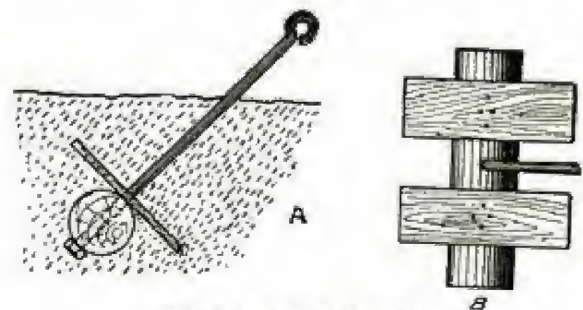

Best Method of Guying

method of doing this. To the guy log, B, are fastened two crosspieces as shown, the rod passing through the center of the log and fastened with a nut (Fig. A). Its position is clearly shown in the sketch.

The quantity of pure platinum produced in this country during 1903 was 110 ounces, valued at \$2,080. This does not include \$6,000 worth of platinum reported as contained in slimes from copper ore from a Wyoming mine. This is an increase of 16 ounces over 1902, but in 1901 the production was 1,408 ounces of refined metal. For two years the average price has been \$19 per ounce.



### USE OF MURIATIC ACID IN COPPERING STEEL OR IRON.

A few drops of muriatic acid will make copperas take hold of the metal in coppering a surface of steel or iron to take scratch marks, even though the metal be oily. It is not necessary to wait for it to dry; merely wipe off all surplus acid with a rag.

### DEVICE FOR CUTTING WOOD GUTTERS.

Ordinarily gutters are cut on a rip saw with one saw and by turning the stock around. The machine for making wood gutters shown in the sketch is a device of a correspondent of the Wood-Worker and by means of it gutters can be cut in just half the usual time.

It is a combination of two saws, one

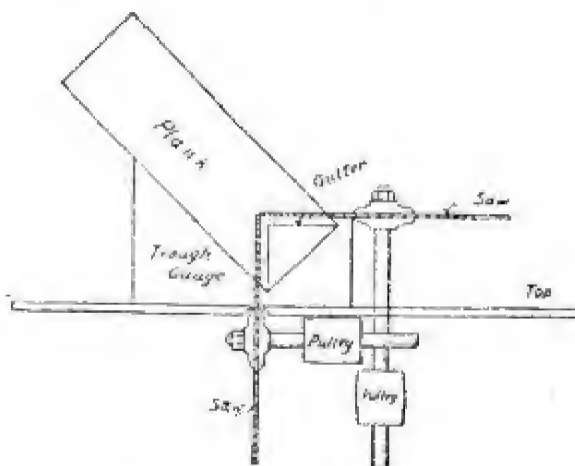

Device for Sawing Wood Gutters

upright and one horizontal, so that the two cuts can be made at one time. When a plank is started all that is necessary is to return it, repeating the operation. Each time the stock passes over the machine one gutter is made, and the operation is continued until the plank is used up, the only waste being the saw kerf and the corners. The same rig can be attached to a self-feed rip saw and the stock fed by power.

### HOW TO CANVAS A BOARD CEILING.

When canvassing a ceiling on which to hang paper, the strips of canvas should first be stitched on the machine into a sheet the size of the ceiling, making each seam about one-half inch, says the Master Painter. The sheet should then be rolled on a pole and the outer edges tacked.

The cloth can be put on so that all the

tacks are on the inside and do not show. To do this unroll the cloth a foot beyond the first seam and have an assistant hold the roll back out of the way. Grasp the seam between the thumb and finger and stretch the first strip and drive tacks one-fourth of an inch outside the stitches through both thicknesses of the cloth as lapped together to make the seam. Proceed in this manner with each seam in its turn until the ceiling is covered, then stretch and tack across the other sides of the room. The side of the cloth which shows will be stretched clean and smooth and the quarter inch between the seam and the tack will let the cloth give and take as the boards shrink or swell and thus keep the cloth from sagging. This method of putting on cloth is called blind tacking. Unbleached muslin should be used.

### POLISH FOR HOT METAL.

The following polish for hot metal is highly recommended by a correspondent of the Engineer:

Take the ash of anthracite coal from under the grate bars and shake through a fine sieve, then use kerosene oil and mix into a good paste. Use any kind of cloth, and apply this to your cylinder heads and rub very hard. Always rub with the grain of metal so you will not scratch it. Leave the paste on until dry, then use a dry cloth and polish it to suit your taste.

### TOOL BOX FOR MILLERS.

For millers or in any trade where such tools as a claw hammer, tack hammer, belt punches, spring punches, screw driver, wire cutter and any number of other small tools are in constant demand the tool box shown in the sketch is especially handy, as the full

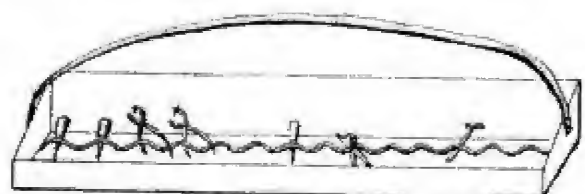

Handy Tool Box

outfit of tools can be carried from place to place or from one part of the plant to another, saving delay and trouble. The box should be from 2½ to 3 ft. long by 8 in. wide at the top, says the American Miller. The sketch explains the construction.



### ECONOMICAL METHOD OF GETTING UP STEAM IN AN EXTRA BOILER.

Starting up an extra boiler a couple of times a week for a few hours only naturally would consume a great quantity of coal to get up steam from cold water. A correspondent of Power who faced this difficulty tells how he got around it and had a supply of hot water ready for emergencies also, he says:

"I put a tee on the blow-off pipe and took a branch to the suction of my boiler feed pump, and before starting up would circulate that water in the boiler through my feed water heater into the front head of the boiler and back again for about an hour, thus warming the water up with the exhaust steam from the engines. This also prevented sudden strains on the boiler, due to getting steam up quickly from cold water."

### HOW TO SLING A BARREL.

It is sometimes necessary to sling a barrel containing small castings and liquids and with both heads on it is an easy job, says the American Machinist, but with one head

### FIRST THING TO DO IN CASE OF ACCIDENT.

Keep cool. Summon a surgeon at once. Send a written message, describing the accident and injury, if possible, in order that the surgeon may know what instruments and remedies to bring.

Remove the patient to a quiet, airy place, where the temperature is comfortable, but never to an engine room, and keep bystanders at a distance. Handle the patient quietly and gently.

Arrange the injured person's body in a comfortable position; injuries to the head require that the head be raised higher than the level of the body; when practical, lay the patient on his back with the limbs straightened out in their usual natural position. Unless the head be injured, have the head on the same level as the body. Loosen the collar, waistband and belts. If the patient should be faint have his head rather lower than his feet. If the arm or leg be injured, it may be slightly raised and laid on a cushion or pillow.

Watch carefully, if unconscious.

If vomiting occurs, turn the patient's body on one side with the head low, so that

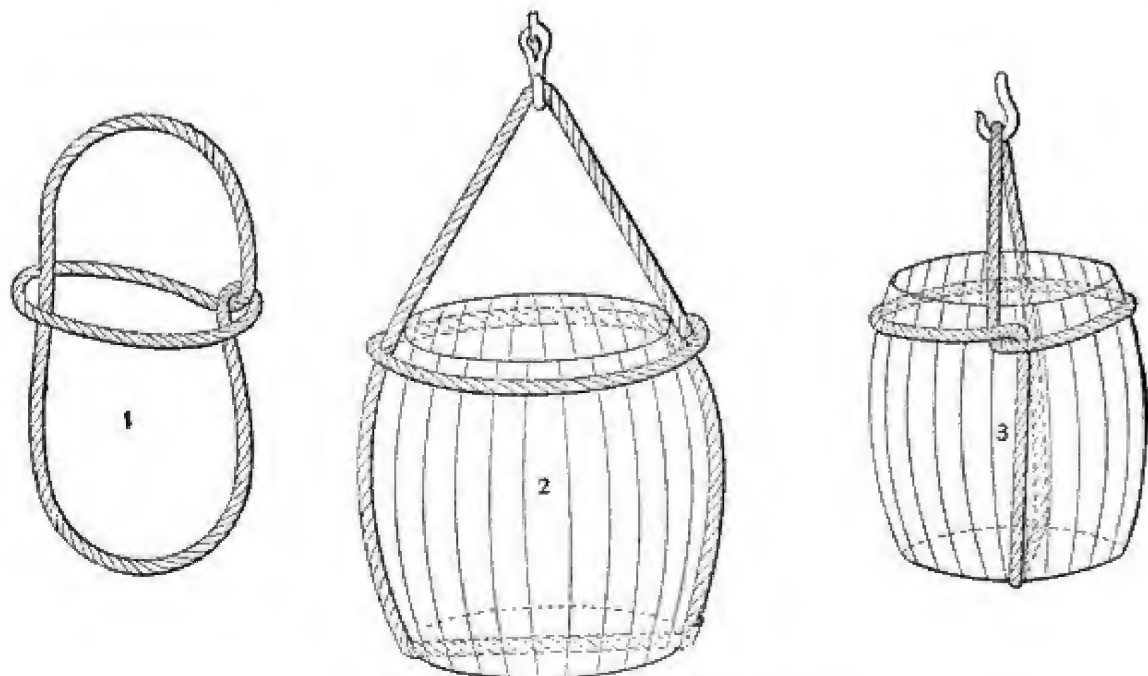

Slinging a Cask Having One Head Out

out, the average workman handles it very awkwardly and uses a great deal of rope in lashing it. Our sketch shows how it may be done with an ordinary sling and in the simplest manner possible.

the matter vomited may not go into the lungs.

If a wound be discovered in a part covered by the clothing, cut the clothing in the seam. Only remove sufficient clothing to



uncover and inspect the wound. In case of burns, pour lukewarm water containing a little baking soda over the clothing before attempting to remove it. All wounds should be covered and dressed as quickly as possible. If a severe bleeding should occur, see that this is stopped, if possible, before the wound is finally dressed. Do not touch the wounds with the hands either during examination or while applying dressings, unless they have been previously made surgically clean. After dressing a wound, do no more to the patient unless necessary to restore him to consciousness or relieve faintness.

If suffering from shock, place him in a comfortable position and await the arrival of the surgeon.

### CLEANING CLOGGED PIPES.

The device shown in the sketch is a tool used by a correspondent of Domestic Engineering for cleaning pipes which have become clogged by a deposit of mud.

The tool is made up of a solid bolt of iron, with a conical-shaped head, A, the

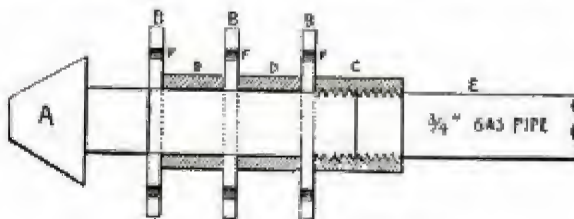

Tool for Cleaning Clogged Pipes

point being moderately sharp for driving with a mallet. Washers, B, of not more than  $2\frac{1}{4}$  inches diameter are slipped over the bolt and kept in position by sleeves (D) cut from gas pipe slightly larger than the shank of the bolt. Not less than four holes should be bored in each washer, as at F, to let the water pass and carry out the mud cut loose by the cleaner.

If the joints are properly made up the  $\frac{3}{4}$ -inch pipe is best, as it does not weigh as much as the 1-inch and two or three men can handle more feet when cleaning. Bolt A should be about 2 inches between head and the coupling; this enables one to hammer loose if the cleaner should become fastened.

To operate, take the tool and insert at the discharge end of the pipe. First connect on length of pipe, shove and pull until this length gets too short, then add another, and so on up to the limit of your power. With four men over 300 feet in a

stretch can be cleaned. Then draw out your cleaner, measure along your pipe line to point it reached, dig out two or three lengths, cut the coupling nearest the discharge, raise the pipe gradually until the free end is above the trench, add a length so as to carry the water away from your pit; then start and work your cleaner as at first, and repeat until the entire line is clean. Bear in mind that each time you cut your pipe the water must be cut off until you are ready to start the cleaner; never attempt to use it until the water is flowing.

### REPAIR FOR A CUT JOURNAL.

For a hot brass in a locomotive that has cut the axle the following method of treatment is recommended by one of our readers, Harry A. Tradsham, foreman of the Canada Eastern Ry. shops at Gibson, N. B., Canada. He says:

Remove the brass and tin it all over the wearing surface and then drop little daubs of solder all over the tinned surface. This will be found a sure cure for a badly cut journal.

### SETTING POLES IN SOFT GROUND.

An excellent method of setting poles in soft ground without sinking them in is given by the American Telephone Journal. It says:

Set the pole in a concrete envelop composed of rubble; one part cement, two parts

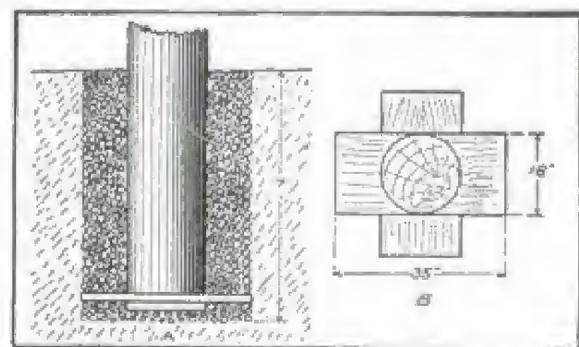

Setting Poles in Soft Ground.

sand, and four parts stone. To the bottom of the pole a platform should be attached, as shown in the figure. This eliminates all possibilities of the pole sinking and at the same time the use of the concrete secures a foundation which has a great amount of stability.



## SOME PIPE PROBLEMS SOLVED.

The following kinks, which may be of practical benefit to other workmen, were given by T. F. McMackin in the Engineer:

Fig. 1 represents a difficult job of pipe-

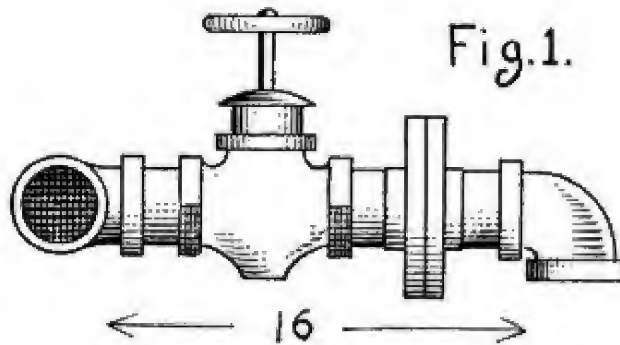

fitting recently done on some boilers installed in New York. The boilers were divided into two sections or batteries, one section being placed in a vault or fire-room directly under the sidewalk, and contained two boilers, one placed on the right of the building. The boiler on the left had just been installed and the steam cut off from that side of the building, the main being kept hot from the boiler on the right, which made it necessary to make connections after 12 o'clock Saturday night.

The mains were 4 inches in diameter and

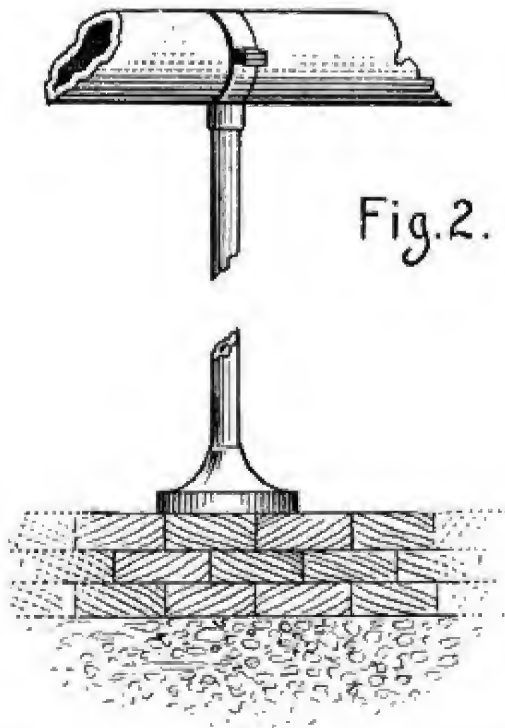

carried cast-iron fittings, the openings between the two tees being only 16 inches apart, as shown. In this instance we had to put in a 4-inch valve, the 4-inch flanges and the necessary nipples. All kinds of

short nipples were tried and discarded. The piece containing the valve was made up on the floor several times, but without success, because both pipes were immovable and could not be sprung 1-16 of an inch. The valve measured 7 inches, the flanges 2 inches, and the three nipples 1½ inches. Finally we made up the two halves on the floor, and by means of a crowbar and several blocks of wood we managed to force them into place.

Fig. 2 represents a supporting column for carrying a steam main between two hot-houses. The distance between the two houses was 15 feet. The column or stand is composed of pipe and fittings and an ordinary pipe-hanger. The main is 5-inch pipe.

In order to render the column secure, a

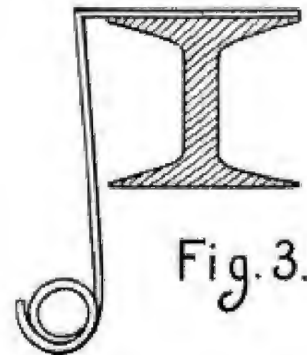

hole 2 feet deep was dug and a foundation built by first imbedding broken stone in cement, and laying on this brick in cement. After placing the flange, the whole was covered with cement, which was heaped up cone shaped around the 2-inch pipe as shown.

An improvised pipe-hanger is shown in Fig. 3. This is made by heating and bending a piece of ¾-inch wrought iron or steel about 5 feet long to fit over the I-beam and bending the lower end to receive the pipe. This is a simple and very good hanger for temporary use.

#### CEMENT FOR CLOSING LEAKS IN IRON PIPE.

The following formula is good for this purpose, but must be used as soon as mixed and rammed tightly into the joint or leak:

Five lb. coarsely powdered iron borings, 2 oz. powdered sal ammoniac, 1 oz. sulphur, and enough water to moisten. This cement hardens rapidly. However, the sulphur may be left out and it will set even more firmly, but require a longer time.



## KEYS FOR SHAFTS.

### Some Common Errors Which Should Be Avoided

Keys for securing pulleys, hubs, gears, flanges and kindred work on shafting are of several kinds: There are the flat keys, the round keys, the oval keys, the oblong keys and even threaded keys. The flat keys are in use for crank shafts of engines, large-sized gears, while the square key is found in use in machine work requiring extra accurate fitting. The illustrations given will assist in distinguishing the different types of strut and feathered keys as found in every-day service in shops, mills and general manufacturing establishments where modern mechanisms are employed.

Figure 1 is the deep setting square key; Fig. 2 the flat key; Fig. 3 the diamond-shaped key and Fig. 4 the round key; Fig. 5 shows the setting of the square key as at A. It is calculated that the sides of the key will sink equally into either part of the union. These square keys can be made to take a very firm grip if tapered right, so as to drive home to the keyway. The oval or partly rounded form of key at B, Fig. 6, is suitable only in special cases. The extremely accurate adjustments of fine mechanical motions cannot be made with this key, unless the work of the parts is light. The key serves for common purposes in light service, however, and may be found in use quite frequently. The diamond-shaped key is not often used. This is shown at C, Fig. 7. The round key is good enough when the parts are of such nature that a true hole may be drilled. Otherwise the key will wobble in an untrue seat and soon loosen and fall out. This key is used sometimes with a threaded shaft, the hole being tapped accordingly.

### Sliding Keys.

The sliding feather is commonly utilized for bearings which are required to move from one side to the other in specific work, such as is required in the case of a clutch. This form of key is also used for spindles for drilling machines in which the shafts or the bosses move. The feather is loose in one seat or the other. Often we find that the combination is made with one key only. In other cases the double key system is used, thereby distributing the service. The feathered key is shown at Fig. 9. This key is not only useful for this purpose, but is the kind employed freely in the set unions and other types of key connections. Figure

10 illustrates another combination sometimes seen in shops and mills. This involves the use of two keys, each made alike, with edges binding one upon the other, and fitted to the coupling, flange, gear or wheel by driving one key at a time each from its own side. The keys thereby bind in the center of the work, and usually quite a substantial grip is afforded on the parts.

### The Tapered Key Seat.

It is essential that the keyway be accurate in proportions. Key systems often fail because of the fact that the key seat is untrue. Sometimes the seat is made smaller at one end than the other, with the intention of using a straight key. Through error, a beveled key is driven in, with the result that the parts bind incorrectly. The parts hold a little while and then work apart.

Sometimes the seats are made with a dove-tail idea in mind, as suggested in Fig. 11. This involves the use of a key similarly shaped, with the "head" extended up into the keyway of the opposite part. Then again some machinists employ a keyway of the type exhibited in Fig. 12 for the purpose of utilizing round keys. The round key is driven home and, of course, presents a proportion of the key above the seat line, and this proportion is what grips in the round keyway of the opposing work. These specially formed keys are useful only in the particular cases in which they are employed.

### Some Mistreatment of Keys.

Figure 13 is a sketch of what one often notices in shops and power plants. It seems queer that this should be the case, but often a really good man gets careless, and unthinkingly delivers a blow to the key he is driving with such force that the collar or the hub is cracked as at E. The parts may cling together indefinitely, even though fractured. Then again the fact that the collar or hub is split, will cause the key to loosen and work its way out. Then a new collar must go on. Sometimes no collars are at hand, then the fractured collar must be strengthened with a band of metal shrunk around it. The set screw is utilized in place of the key now and then. In Fig. 14 we show the set screw substituting the key. In certain instances both the key and the set screw are used.

The set screw point is arranged to contact with the key, and this serves to hold the key in position. Fig. 15 is a sectional sketching of a combination given to illustrate



the carelessness of key insertion at times. This error was observed in a first-class shop. The parts were of such nature that the fastening key had to be driven through the sleeves to the shaft, much as pins are

supply produced heating, grating and wearing off of the metal. The arrangement had to be taken apart and restored with proper key-setting.

In another case a patched collar was used

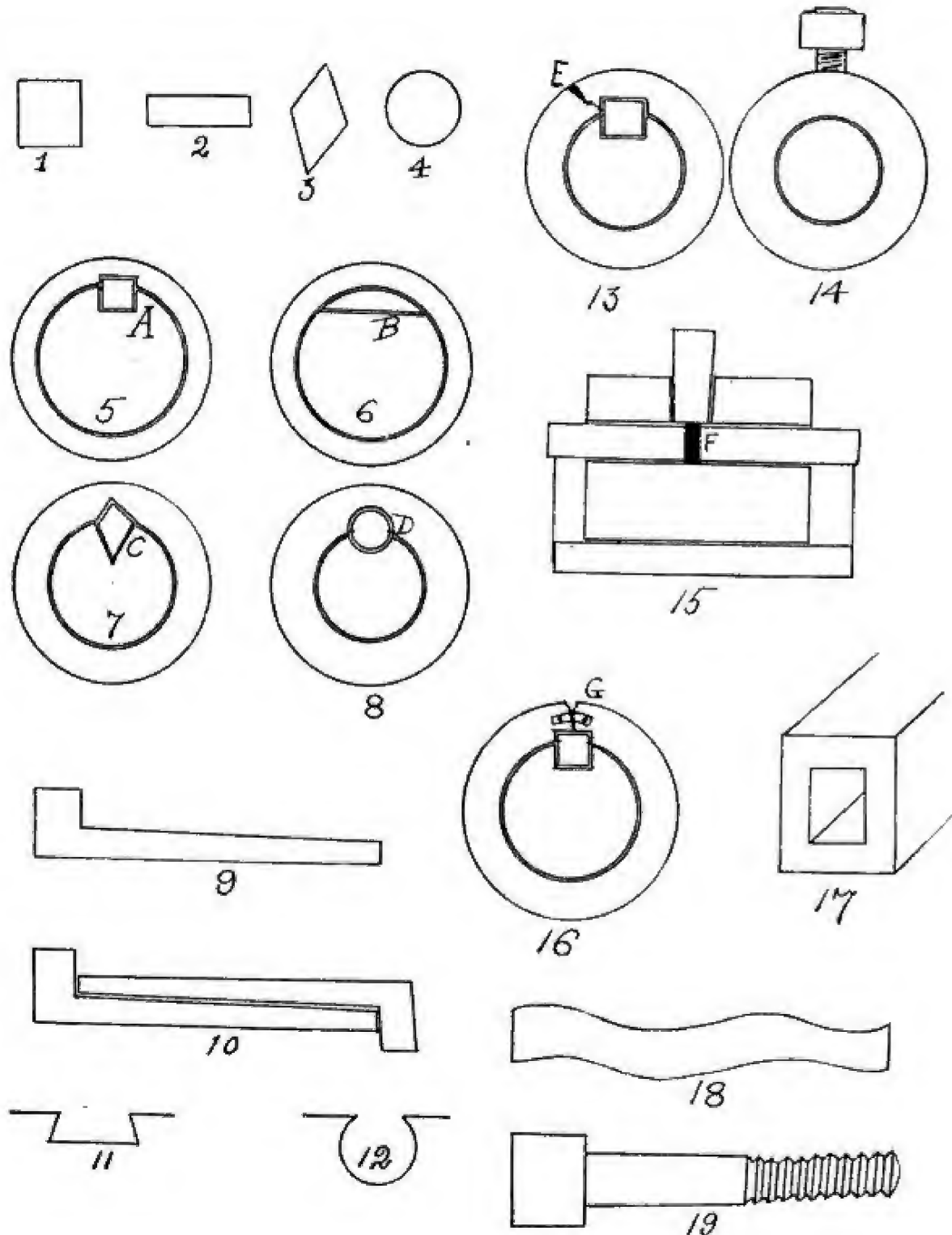

used. The drawing shows the parts at the center bearing where the oil hole is completely closed by the point of the tapering key as at F. This combination ran well for a few weeks, then the stopping of the oil

on a shaft, keyed as in Fig. 16. A piece of strap metal G was riveted over the open parts. This developed a weakness in the collar, so that although tight, the key could not retain a positive bite on the metals, and



constantly worked free. The workman would drive the key home with a blow with the hammer now and then. This collar was substituted finally with a perfect one. A hollowed key is shown in Fig. 17. This was made for a large overshot water-wheel shaft of wood. The key itself is constructed from hardwood, with the hollow fitted with a shaft of metal. Thus the big wooden hub of the overshot wheel is secured to its shaft with a wooden key strengthened with a core of metal. The curved key seems to be a strange affair, still they may be found in use. Fig. 18 is a drawing of the snake-like pattern. This key cannot be driven. The seat for the key is modeled out in both the shaft and the hub of the work to receive the curls, and the curled key is dropped into place. It is curved likewise to suit the conditions of the roundness of shaft and hub. Figure 19 is a set screw made in key form. The key is made first, in rounded form, and then the threads are cut. This style of key is practically a threaded shaft.

"MACHINIST."

---

#### A NOVEL WAY OF BUSHING A FLY-WHEEL.

---

In a certain shop, where I worked some time ago, I was amused as well as interested at a job they were doing, writes one of our readers.

In one department of their works they had about a 22-horsepower steam engine, and for some reason or other the foreman of the department wanted a heavier flywheel put on. Finally a little heavier one was found, being about  $4\frac{1}{2}$  feet in diameter, 10-inch face and 3-inch bore. The engine crankshaft was  $2\frac{1}{2}$  inches in diameter, consequently it required a bushing  $\frac{1}{4}$  inch thick.

The job of making the bushing was given to the machine shop and within a few hours it was ready. The bushing was put into the flywheel, and the wheel slipped on to the shaft and tightened. (The foreman of the department was standing watching the job without a word, as he had nothing to say over the machinists.) Finally the engine was started, and to the men's surprise the face of the wheel ran out considerably. They at once set aside to make new bushings, and in the meantime our foreman was getting very angry over what he called a bum job and besides the time lost in stopping the engine.

All looked for a warm time when they started to bush it the second time, and cer-

tainly were not mistaken. When the second bushing was finished and after considerable time spent in getting the old one off, it was finally placed on the engine again, ready to run. When the engine was started it ran out the same as the old one. They stood and watched it for a few minutes, until the boss got mad and told them to go back to their department, that he could do a better job with a rough sheet-iron bushing. The boys were rather offended at this and said he would never get it bushed to run true. "Well," said Mr.—, "I'll bet any one of you \$50 that I will take a rough sheet-iron bushing and bush that wheel to make it run perfectly true." This seemed like a one-sided bet in favor of the boys, and they were overly-anxious to take it, and agreed to do so. The boss gave them until next day to get the money. The next day came, but no money was up by the boys, and the boss must have been in good humor, for he went out to the machine shop and told the several machinists who had helped on the job to come in and he would teach them something free of charge.

He straightway set about and took a piece of  $\frac{1}{4}$ -inch boiler plate and bent it around a shaft until it fitted the flywheel (this bushing was not turned on the outside, but left rough), he then put the flywheel on to the shaft and started up. It ran out ten times as badly as the boys' job and, consequently, they all laughed. But, alas! the job was not done yet, and he evidently had started it to see what they would say; at the same time he knew it would be worse. He never said a word, but picked up a piece of chalk, and while yet running marked the wheel where it was out. When they stopped the engine he took a fuller and, by aid of a helper striking, he caulked the side opposite to where it ran out, and by starting and stopping a few times to chalk and true the wheel, he had done the job within three-quarters of an hour after it was placed on the engine, and a more perfectly running flywheel on an engine you never saw.

This job proved very interesting to me and I thought it was well done, and I trust it will interest all who read it. N. M.

---

The article "Trimming Arc Lamps by Automobile," appearing in our November issue, was by mistake credited to the Western Electrician. This method was first described in the columns of the Bulletin of the New York Edison Company.



## LAYING A COPPER ROOF.

A copper roof laid with 140-lb. copper costs, including material and labor, about \$35 per square. Such a roof will last a long time. The Metal Worker gives excellent directions for the work. If a rib roof is desired use dressed wood strips 2 in. square, with the strips 20 in. apart. The cuts show manner of turning the edges. The copper is rolled out and  $2\frac{1}{2}$  in. turned up square on each side, then  $\frac{1}{2}$  in. is turned in square toward the center of the sheet.

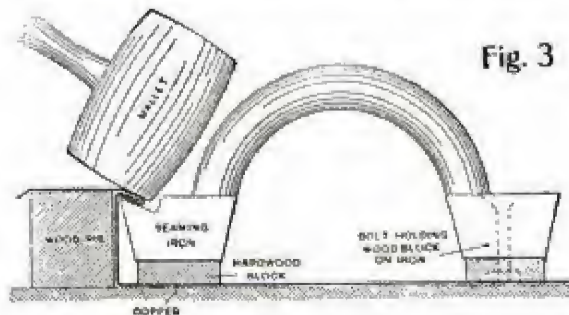
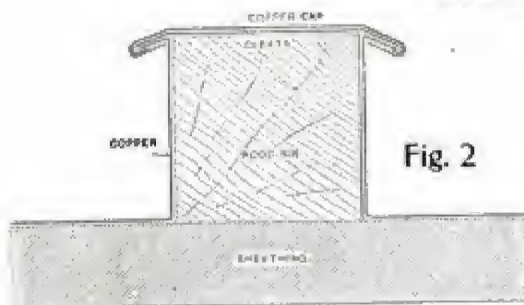
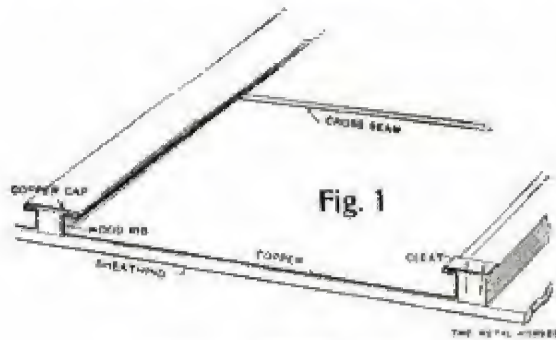

This edge is then cleated at intervals of about 6 or 8 in. to the wood strip. A cap strip of copper, cut about 4 in. wide, is then locked onto the edges of the copper, covering the wood rib and hiding the cleats. No nails should be driven through the copper. The sketch, Fig. 1, shows the method better than any written explanation.

Whether put on with ribs, as above described, or like a standing seam roof, the copper should be put together in rolls the same as tin; only it is preferable to use long sheets instead of 14 or 28-in. sheets, thereby lessening the amount of copper, solder and labor required. If the ribs are spaced 20 in. apart it will be found that

there will be required to cover the space from the edge of one rib to the corresponding edge of the other rib, 4 in. for the cap, plus  $\frac{1}{2}$  in. on the top of the course, plus 2 in. up against the rib, plus 18 in. to the next rib, plus 2 in. up, plus  $\frac{1}{2}$  in. out, or a total of 27 in. is required to cover 20 in., net, of space.

A nice way of closing up the edges after the caps are put on, and also of turning the same down slightly, is to take an ordinary seaming iron, such as is used on tin roofs, drill two holes through it on each side, bolt on hardwood strips on each side, thick enough to raise the iron to the desired height, and then have it channeled out on one edge to the desired bevel. Then, by running it along the seam, the edges can be closed tight with a mallet and turned down to the angle desired at the same time. This operation is shown in the sketch, Fig. 3.

## PUSH-GUYING TELEPHONE POLES.

Sometimes in constructing telephone lines a pole is so located that it cannot be guyed directly to the ground, says the American Telephone Journal, and the guy wire must

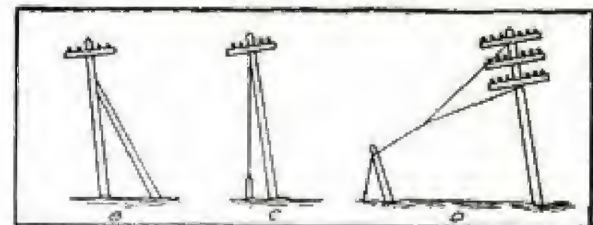

Push-Guying Poles

be taken across a road. If there is a tree convenient it may be attached to that, but if not it must be push-guyed, as shown in the sketch.

The push guy, B, is a pole set so as to lean towards and against the pole carrying the wires and is firmly fastened to it near its top. The push guy thus serves to push the pole away from the direction of the strain of the wires. A method of guying a pole from a point near its butt by means of an anchor is shown at C, and D shows a "Y" guy for heavy leads.

## TO LETTER ON CANVAS.

In lettering on canvas, if the canvas is first dampened with water, the paint will not spread, nor will it dry too soon.



### BRAZING CAST IRON.

Brazing cast iron is no longer one of the things which cannot be done. On the contrary, in the hands of an experienced workman the results are extremely satisfactory. In places remote from sources of quick supply the process is almost invaluable. A correspondent in the Blacksmith and Wheelwright tells his method.

We take a hack saw and put into the broken parts like Fig. 1, then we put in

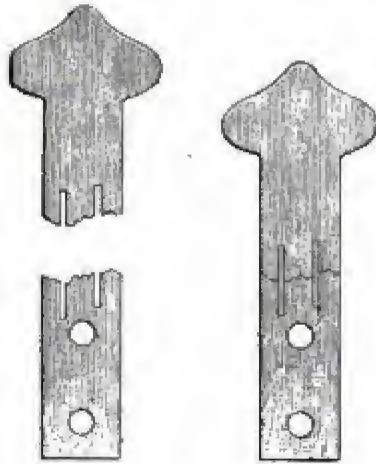

Fig. 1

Fig. 2

Brazing Cast Iron

a piece of steel like Fig. 2 to hold the parts in place while brazing, then place in the forge and apply the brazing compound. Powdered borax will answer the purpose, but leaves more scale on than the brazing compounds. After the iron is heated to a bright red and the flux has flowed over the joints, apply the brazing spelter with an iron (one-fourth inch flattened on one end will do) and heat until the brass flows freely over all parts of the joint; then remove from fire and let cool slowly. If plunged in cold water while hot the sudden contraction may spoil the brazing. We use a three-burner gasoline brazing forge, and can do a much better job on it than can be done in an ordinary forge. There is not as much danger of burning the iron and one can always see what he is doing, besides it makes a much cleaner fire than coal.

We have successfully brazed brass castings and some very difficult iron castings. We do a large amount of boiler work, such as retipping flues, etc., and braze all the flues, making a much neater and stronger job than can be done in welding, and consider this forge as one of the best investments a smith can make, as many times it

will save a thresherman or farmer a delay in the busy season. In successfully brazing cast iron all grease should be removed and paint (if there is any) should be removed from the near joint.

### AUTOMATIC ELECTRIC CIRCULAR SAW MILL.

A man who owns a large plantation on the island of Sumatra has invented an automatic electric circular saw mill which is a great improvement in this line.

Two kinds of mills have been fitted up—log saws and resaws and in both the saw is fed along the log instead of feeding the log to the saw. In the log saw mill an iron track is made fast to the middle line of the log by means of clamps extending down to grip the center of the log. A carriage bearing a small electric motor runs on this track and on the under carriage is a cross carriage which can be rotated about a vertical axis by means of a handwheel and a screw. This cross carriage bears the principal motor that carries the saw. The small motor feeds the carriage along the track and the large motor runs the saw through the wood during the cut. By means of the cross carriage or slide the saw can be fed across the log the width of the board to be cut plus the kerf and by turning the carriage on the vertical axis the saw can be turned 90 degs. about the axis and makes a cut in the reverse direction at the same speed as in the first cut. This avoids shock at the reversing points and also saves time.

"The resaw," says a correspondent of the Wood-Worker who saw the invention in operation, "is lighter and more simple. The balks or planks are laid on round wooden supports and piled up to the maximum height of one foot. The planks are clamped together. The track and carriage are then set on the pile and fastened thereto by clamp bolts at the ends."

Power can be brought any distance to the machine by insulated wires, in this instance it was brought a distance of 3250 yds. and for small logs 60 h. p. was required.

Twenty-eight-inch logs can be cut by a saw 6 ft. in diameter. For logs larger than this a cut is made to the depth the saw can handle and the saw is then turned 180 degs. about its axis and a cut made from the opposite direction. This is claimed to be the single weak point of the apparatus, for a little lost motion in the machine will cause the kerfs to come blind.



## MEASURING WASTE HEAT FROM GAS ENGINES.

A method of measuring waste heat carried off in the exhaust from gas engines consists of a calorimeter mounted in the course of the exhaust gases, close to the engine, in which the gases are cooled by jets

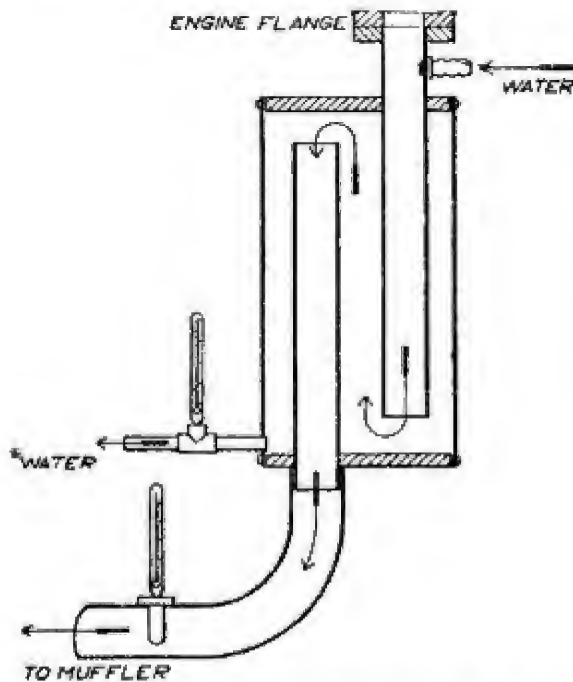

Method of Measuring Waste Heat from Gas Engines.

of water in such a way that the temperature of the entering and outflowing water can be readily ascertained. A very simple form of this device is shown in the sketch by means of which the gases from a 10-hp. engine were cooled to 107 deg. F.

The calorific value of the gas supplied to the engine was determined and its quantity measured, while the indicated horsepower, the rise in temperature of the circulating water, and the heat carried off in the exhaust were observed. The engine had a cylinder 7 in. in diameter, and a stroke of 15 in., and ran at 250 revolutions per minute.

The results showed that the jacket water carried off 32 per cent of the heat energy supplied to the engine, the exhaust gases gave up 34.5 per cent to the calorimeter and carried away 1.5 per cent to the chimney, and the indicated work amounted to 26 per cent of the total energy, leaving 6 per cent unaccounted for. The temperature of the gases was reduced to 107 deg. F. in the calorimeter, the jacket water at exit was at a temperature of 105 deg., and the indicated

horsepower was 14.2. The missing 6 per cent was mainly attributable to radiation and conduction from the engine.

## RECIPES FOR POLISHING BRASS.

Three parts oxalic acid dissolved in 40 parts hot water; add 100 parts powdered pumice stone, 2 parts oil of turpentine, 12 parts soft soap and 12 parts fat oil.

Or: Four oz. rottenstone, 1 oz. oxalic acid in fine powder, 1½ oz. sweet oil, enough turpentine to make a paste.

## SIMPLE METHOD OF WINDING COIL SPRINGS.

Coil springs of any pitch and of wire up to ¼ inch in diameter may be wound by the simple device shown in the illustration, says a correspondent of the American Machinist. Make a winding mandrel of a piece of iron rod about 1-32 inch smaller than the inside diameter of the spring is to be. Bend a crank on one end and drill a hole for a wire inlet. Near the other end clamp two softwood blocks in the vise with the mandrel in position, small hole up. Insert the wire and turn the crank.

The pitch can be regulated by holding the wire at the proper angle. When the

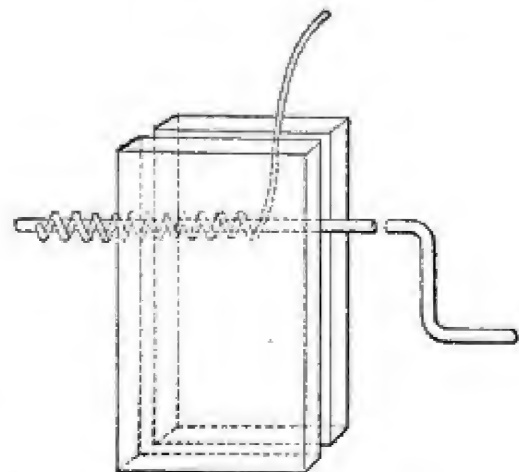

Winding a Coil Spring.

spring reaches the outside of the blocks it has cut grooves in the wood corresponding to the pitch of the spring. On short springs the pitch can be duplicated, or a spring can be made of any length by opening the vise slightly, pulling back the mandrel and clamping the spring to the mandrel with a lathe dog. Springs made in this way acquire a good polish.



### A TABLE OF PRINCIPAL ALLOYS.

A combination of zinc and copper makes bell metal.

A combination of copper and tin makes bronze metal.

A combination of antimony, tin, copper and bismuth makes britannia metal.

A combination of copper and tin makes cannon metal.

A combination of copper and zinc makes Dutch gold.

A combination of copper, nickel and zinc, with sometimes a little iron and tin, makes German silver.

A combination of gold and copper makes standard gold.

A combination of gold, copper and silver, makes old standard gold.

A combination of tin and copper makes gun metal.

A combination of copper and zinc makes mosaic gold.

A combination of tin and lead makes pewter.

A combination of lead and a little arsenic, makes sheet metal.

A combination of silver and copper makes standard silver.

A combination of tin and lead makes solder.

A combination of lead and antimony makes type metal.

A combination of copper and arsenic makes white copper.

### WHY FLYWHEELS BURST.

A simple explanation of the operation of a flywheel in bursting appears editorially in Page's Weekly, London, as follows: The tension upon the rim of a revolving wheel augments as the square of the velocity—that is to say, supposing for the moment that we had a wheel with a rim a foot square, revolving at the rate of 100 feet per second—the material being cast-iron—the total resolved forces tending to tear the rim asunder would be, say 144,000 pounds. Now, imagine this velocity to be increased by the failure of the governor to act, or otherwise, to 150 feet per second, or one and a half times as fast as before—a perfectly possible case—and we have 324,000 pounds to deal with. Double the original speed, and we have 576,000 pounds.

Just one more fact about our hypothetical wheel before we turn these figures to account. Supposing the wheel to break up under the stress due to the last-named speed

—200 feet per second—there is energy resident in that rim sufficient to project any part of it which might happen to be discharged vertically 600 feet into the air. This will give some idea of the potential force lying dormant in a flywheel. A well-known American writer who has made this subject his specialty, thus records his opinion: "A flywheel is just as dangerous as a boiler, and should be subject to inspection in like manner. The time to investigate a flywheel is during its lifetime, and the one to investigate it is a trained inspector, who can pronounce intelligently on its safety, or condemn it if dangerous."

The bursting speed of a solid cast-iron rim—i. e., without joints and free from contraction stresses, is about 425 feet per second. If the rim be built up of several parts, the sectional area at the joints may be reduced by recessing for dowels or cramps, to an extent which at once lessens its ultimate strength by one-half. It is too much to expect the joints to be of equal strength with the solid metal, but in proportioning the relative sectional areas of cast-iron rim and steel bolts or cramps it is not difficult to arrange them inversely as their respective tensile strengths, and so obtain the maximum efficiency.

Wheels with deep rims should never be joined by internal flanges and bolts; centrifugal force tends to open the joint and bring a leverage to bear upon the bolts which may be as much as four to one, compared with the same bolts in direct tension.

In the case of thin-rimmed wheels, as rope or belt pulleys, for example, where internal flanges are almost a necessity, this leverage is not nearly so pronounced, but still it exists, and should be taken into account.

Each rim-section of a wheel, built up of segments with the joints midway between the arms, is in the condition of a beam supported at the ends, and uniformly stressed. The maximum bending moment occurs, of course, at the centre of the beam, and consequently the joint is in the least favorable position possible. It should be either at the arm or as near to it as practicable.

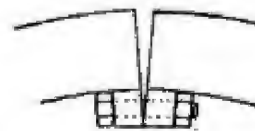

Inasmuch as the term Manual Training School is said to be no longer definite, it is suggested that it be called Industrial Art School.



### PISTON RINGS.

A correspondent to the National Engineer writes as follows regarding the development of piston rings, and the advantage of steel packing rings over cast-iron rings:

Many years ago railroad master mechanics employed spring steel packing rings in the cylinders of locomotives, and at first they thought they had a good thing. The piston consisted of a spider, a follower, a spring steel bull-ring set out by three elliptic springs and two spring steel packing rings. The packing wore down very rapidly and the engineers were continually complaining of "blowing" pistons, which necessitated constant setting out of the packing. After some time the use of steel rings was abandoned, and bab-bitted brass packing rings substituted for them, the same spider, etc., being retained. This packing gave better satisfaction than the steel rings, but still it did not completely fill the bill, since the engineers still complained of "blowing" pistons. Later on a man named Dunbar invented a steam packing. This packing was made entirely of cast iron, and consisted of a large number of segments of a circle, and it was set out by the action of the steam in the cylinder. This packing was durable and gave most excellent satisfaction, but there was one objection to it, and only one, but a serious one—it was entirely too expensive to make and fit in the different sized cylinders. After a time a man named Stevenson invented a substitute for Dunbar packing. Stevenson packing consisted of a cast-iron solid bull-ring—that is, the ring was not cut across—and two cast-iron packing rings. The bull-ring was centered on the piston and then pinched in place by the follower. The packing rings were cut across diagonally, and they were set out by their own tension. This packing was cheap to make and gave the best of satisfaction. After a time master mechanics came to the conclusion that they could very well dispense with Stevenson's bull-ring and follower while retaining his cast-iron packing rings. This led to the adoption of the cored solid piston with two grooves sunk in it to admit the packing rings, which, as in the other case, were set out by their own tension. This arrangement makes the cheapest and best piston ever put into a steam engine cylinder. Spring-steel contains but  $\frac{3}{4}$  per cent of carbon, while the iron in a steam engine cylinder contains

$3\frac{1}{2}$  per cent of carbon. Thus it will be seen that the packing rings when made of spring-steel—the softer metal—will wear down very rapidly.

### TO PREVENT WATER FROM FREEZING.

A fire insurance company in one of its reports calls attention to the use of chloride of calcium in small quantity at little cost in buckets and pails where the water may freeze in very cold weather. This material can be had on a large scale. It tends not only to prevent freezing but in a certain measure acts like salt in preserving the water from deterioration.

### FISHING TOOLS FOR USE IN DEEP WELLS.

The job of fishing broken rods from deep wells has occasioned many a man no end of trouble and loss of time. A correspondent of Power has devised a tool for fishing for rods and another for pipes which he used successfully for this purpose. He says:

"I had a 4-in. pipe 21 ft. long drop to the bottom of my 300-ft. well, wedging itself

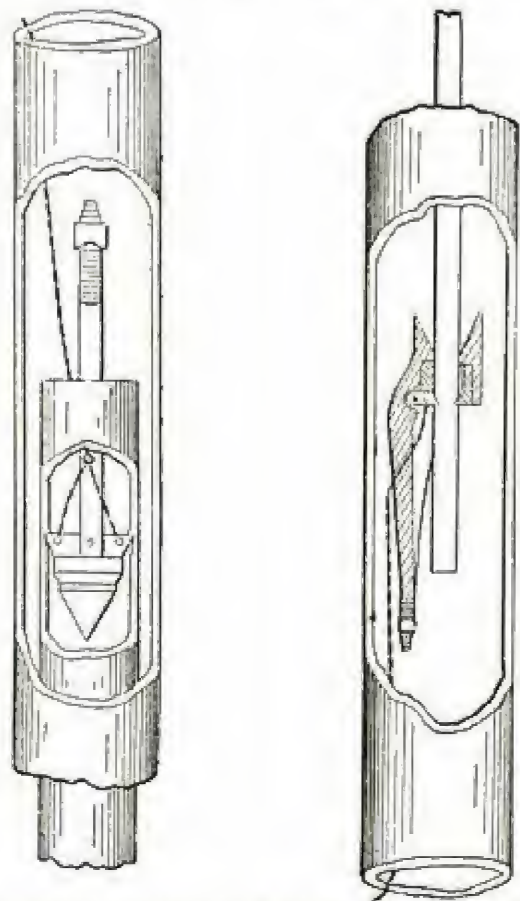

Tools for Fishing Broken Rods and Pipe Out of Wells



in a tapered hole. It had a coupling on the lower end and it was no easy matter to pull it. Having broken several tools, I designed this one which did the trick, standing a pressure of about 25 tons on the jacks before it loosened. You will see I have applied the same method for lifting rods. I use different sized bushings for various sized rods. The pawl works against a bearing in the carrier and has an oblong hole so as to relieve the shearing strain on the rivet. The ring on one tool and the bushing on the other are the fulcrum for the pawls to rest on.

**POWER REQUIRED FOR AIR LIFT.**

The following data may be of interest to readers who have to deal with the air lift, says A. H. Goff of Roswell, N. M., in the Engineer. For the proper working of an air lift a certain amount of submergence is necessary. For the most economical and efficient results a submergence of 60 per cent should be used. That is, 60 per cent

RATIO OF WATER TO AIR REQUIRED.

For Lifts Not Exceeding			
25 feet	2	vols. of air	to 1 of water
50 feet	3	vols. of air	to 1 of water
75 feet	4½	vols. of air	to 1 of water
100 feet	6	vols. of air	to 1 of water
125 feet	7½	vols. of air	to 1 of water
150 feet	9	vols. of air	to 1 of water
175 feet	10	vols. of air	to 1 of water
200 feet	12	vols. of air	to 1 of water

VOLUME OF FREE AIR, AIR PRESSURE, SUBMERGENCE AND HORSEPOWER.

Lift Ft.	Submergence Ft.	Air pressure.	Free air per min Cu. ft. per gal.	I. HP. per gal.
25	38	17	0.3	0.0184
50	75	33	0.4	0.0426
75	113	49	0.6	0.0828
100	150	65	0.8	0.1320
125	188	82	1.0	0.1910
150	225	98	1.2	0.2544
175	263	115	1.4	0.3150
200	300	130	1.6	0.3868

of the total length of the water discharge pipe should be below the water level in the well when pumped to its full capacity. For instance, let us assume that in a well 200 feet deep when pumping the water sinks to 40 feet below the surface of the ground, and it is desired to lift the water 20 feet above the surface of the ground. This gives a length of pipe 60 feet to the water level

in the well, and, as this does not include the submerged part of the pipe it is only 40 per cent of the total length of water discharge pipe, the total length will, therefore, be 60 feet plus 1½ times 60 or 90 feet submergence, making a total length of 150 feet of water discharge pipe.

It is not safe, unless under very favorable conditions, to figure on raising the water by the air lift system more than 200 feet above the lowest water level in the well. Nor is it always safe to extend the horizontal discharge more than 500 feet, as the air lift is not adapted to pumping horizontally to any great distance, unless reinforced by a pneumatic direct pressure pump, or an ordinary piston pump. Either of which, however, could be operated by compressed air from the same pipe that supplies the well.

Suppose, for instance, that it is desired to lift 120 gallons of water 100 feet high per minute. It will be seen by the above table that this will require 150 feet submergence, thus making 250 feet of water discharge pipe, 65 pounds air pressure, 96 cubic feet of free air per minute and a compressor developing 15.84 horsepower.

**GOOD ARRANGEMENT OF BOILER FEED AND BLOW-OFF.**

A very satisfactory arrangement of an internal feed pipe and a blow-off connection is shown in the accompanying sketch. The pipe, which is larger than is generally used, makes a circuit of the boiler, entering at about the water line at the front head and

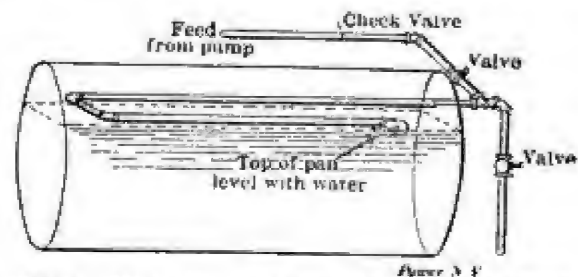

BOILER FEED AND BLOW-OFF ARRANGEMENT.

terminating in a pan, the top of which is level with the water line. The feed water passes slowly through the pipe and is heated enough to precipitate much of the scale-forming matter. When the blow-off is opened, says a correspondent of Power, it is surprising to see the amount of mud that will be blown out.

Bound volumes of Popular Mechanics, limited number, \$3.00.



### TO MAKE BLUEPRINTS BROWN.

Young as well as older photographers may be interested in learning how to make blueprints turn brown. The method is simple. Dissolve a piece of caustic soda the size of a kernel of corn in about five ounces of water. Immerse the blueprint in this till the print changes to an orange yellow. Then wash the print thoroughly in a bath composed of a heaping teaspoonful of tannic acid dissolved in eight ounces of water. You may leave the print in this mixture till it has become the desired tint of brown, after which thoroughly wash the print and allow it to dry slowly.

### HOW TO BUILD A STOCK CART.

Any farmer can make his own stock cart after the manner of the one shown in the illustration and will find it a great convenience whether he has much stock or not.

The cart has a drop axle (A) worked over at a blacksmith forge from two discarded buggy axles. It should be left standard track width and have pieces 1 ft. long inserted near the stubs at each end to form the drop. This is to bring the bed nearer the ground. The bed can be made of any lumber about the farm and should be just the width to fit into the axle

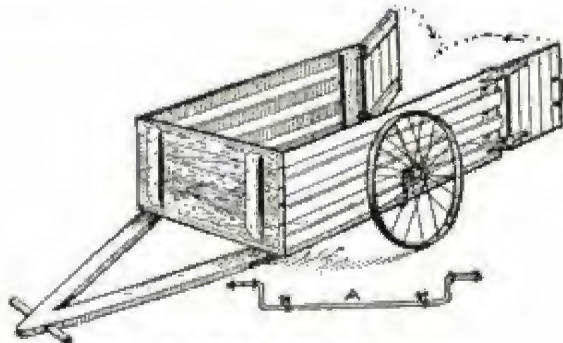

A Handy Stock Cart

and 5 ft. in length, and bolted to the axle near the middle of the bed. Bolt a cart handle on the front and fit the rear with two doors and a strong latch. Mount the whole on wheels and, according to a correspondent of the Ohio Farmer, you will have a "stock chariot" which cannot be surpassed.

This cart can be readily backed up, when mounted upon wheels, to any pen, the rear-end dropped to the ground, doors closed behind, the cart attached to the rear of any other vehicle, and the animals transported as many miles as desired, with ease. By

making the front end-gate and cart handle detachable, this "rigging" can be wheeled up to the rear of a wagon and used for a chute in loading hogs or sheep.

### DEVICE FOR TRUING COLLECTOR RINGS.

The machine shown in the sketch was fitted up by a correspondent of the Engineer, for truing up badly worn cast-iron rings on

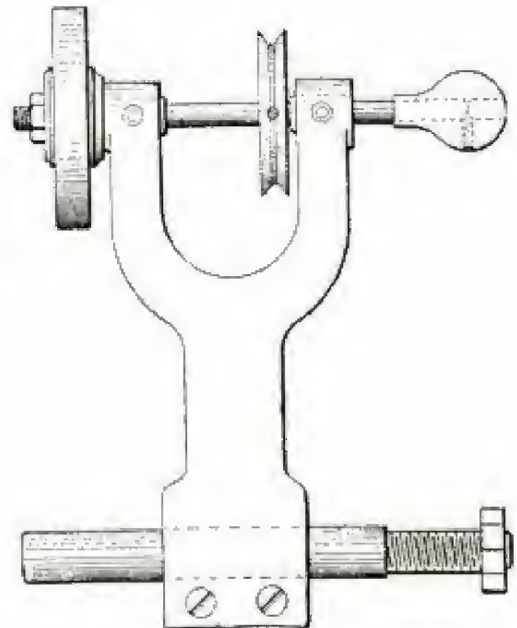

Machine for Truing Collector Rings

a G. E. compensated revolving field alternator. He describes its operation as follows:

The emery wheel is passed across the rings while the machine is running slowly. The wheel is run at a speed of 3000 revolutions per minute by a small motor. It puts the rings in fine shape and saves taking the head to a machine shop. Then, too, while turning the rings they are liable to get out of place. Strips bolted in where the brush-holder is taken off and the rig clamped to the bolt by two screws, the bottom of the casting being split to insure a tight grip, will serve the purpose.

Very few people can draw two different pictures simultaneously, but an Englishman, Sir Edward Landseer, recently proved that he could. With the right hand he drew the profile of a stag's head with antlers, complete, while with the left he drew a horse's head. One drawing was as good as the other and the acts of draftsmanship did not alternate.



# Tables Showing the Percentage of Cotton, by Weight, on Magnet Wires of Various Sizes

**These Valuable Tables, Which We Have Not Seen Anywhere in Print, are Contributed by W. S. Holmes**

## RECTANGULAR WIRES.

### Single Wound.

Size.	Per Ct.	Size.	Per Ct.	Size.	Per ct.
.070 x .050	.019	.225 x .028	.0175	.350 x .090	.008
.074 x .056	.0175	.232 x .020	.022	.355 x .075	.009
.090 x .054	.017	.240 x .075	.011	.355 x .120	.009
.092 x .050	.0175	.250 x .075	.011	.360 x .100	.007
.095 x .075	.013	.260 x .064	.0195	.360 x .105	.0085
.100 x .050	.015	.270 x .070	.010	.360 x .110	.006
.100 x .065	.014	.280 x .062	.0105	.370 x .064	.0095
.100 x .074	.013	.280 x .095	.007	.375 x .075	.0085
.100 x .080	.0115	.300 x .080	.009	.375 x .090	.008
.105 x .090	.011	.300 x .110	.0065	.380 x .065	.0095
.122 x .095	.010	.310 x .060	.012	.390 x .110	.006
.125 x .070	.0125	.320 x .075	.0095	.420 x .115	.006
.125 x .115	.0095	.320 x .082	.009	.435 x .110	.006
.135 x .095	.0095	.320 x .125	.0055	.4375x .065	.009
.140 x .505	.015	.330 x .035	.019	.460 x .080	.0085
.200 x .030	.017	.335 x .115	.006	.490 x .105	.006
.200 x .042	.012	.340 x .045	.014	.5025x .084	.008
.200 x .070	.012	.340 x .088	.008	.550 x .110	.0055
.215 x .055	.012	.350 x .080	.009	.675 x .052	.011
.215 x .090	.008				

### Round Wires.

No.	Size.	Per ct. S. W.	Per ct. D. W.
2	.2376	.097	.010
3	.2294	.099	.011
4	.2043	.097	.012
5	.1810	.098	.013
6	.1626	.099	.014
7	.1443	.010	.016
8	.1285	.011	.018
9	.1144	.013	.020
10	.1019	.012	.022
11	.0907	.013	.024
12	.0808	.015	.027
13	.0719	.018	.030
14	.0640	.021	.033
15	.0571	.022	.037
16	.0508	.026	.041
17	.0453	.030	.046
18	.0403	.033	.055
19	.0359	.036	.059
20	.0320	.038	.062
21	.0285	.040	.070
22	.0253	.041	.080
23	.0226	.045	.094
24	.0201	.051	.097
25	.0179	.048	.100
26	.0159	.052	.115
27	.0142	.060	.135
28	.0126	.072	.155
29	.0113	.087	.190

### Size.

Size.	S. W. Per ct.	D. W. Per ct.
30	.0100	.210
31	.0089	.220
32	.0080	.250
33	.0071	.300
34	.0063	.340

### Square Wires.

Size.	Per ct. S. W.	Per ct. D. W.
.068 x .068	.016	.026
.064 x .064	.015	.026
.075 x .075	.013	.023
.072 x .072	.012	.023
.077 x .077	.011	.023
.081 x .081	.010	.021
.085 x .085	.009	.021
.0907 x .0907	.008	.021
.098 x .098	.007	.017
.108 x .108	.006	.017
.1144 x .1144	.005	.019
.120 x .120	.004	.017
.121 x .121	.003	.017
.128 x .128	.002	.016
.135 x .135	.001	.018
.143 x .143	.001	.013
.162 x .162	.001	.014
.187 x .187	.001	.013
.195 x .195	.001	.013
.225 x .225	.001	.010



RECTANGULAR WIRES.		Size.	Per Ct.	Size.	Per ct.
		.200 x .095.....	.019	.300 x .110.....	.014
		.200 x .105.....	.018	.300 x .115.....	.014
	Double Wound.	.200 x .120.....	.015	.300 x .120.....	.014
		.210 x .070.....	.022	.300 x .140.....	.011
		.210 x .125.....	.014	.310 x .060.....	.023
.034 x .071.....		.210 x .155.....	.011	.310 x .065.....	.022
.092 x .071.....		.215 x .085.....	.019	.310 x .120.....	.013
.100 x .050.....		.215 x .105.....	.015	.320 x .195.....	.015
.100 x .063.....		.215 x .140.....	.013	.325 x .160.....	.011
.100 x .085.....		.219 x .167.....	.010	.340 x .040.....	.025
.104 x .091.....		.220 x .045.....	.028	.340 x .050.....	.023
.110 x .096.....		.220 x .070.....	.022	.340 x .060.....	.022
.120 x .050.....		.220 x .095.....	.018	.340 x .080.....	.019
.122 x .105.....		.220 x .115.....	.015	.340 x .090.....	.016
.125 x .040.....		.220 x .120.....	.014	.340 x .100.....	.014
.125 x .075.....		.220 x .125.....	.013	.340 x .125.....	.013
.125 x .095.....		.220 x .193.....	.0095	.340 x .175.....	.009
.130 x .070.....		.225 x .022.....	.051	.345 x .100.....	.014
.130 x .100.....		.225 x .025.....	.046	.350 x .100.....	.014
.131 x .090.....		.225 x .055.....	.027	.350 x .130.....	.011
.141 x .109.....		.230 x .190.....	.010	.360 x .085.....	.018
.141 x .095.....		.232 x .132.....	.013	.365 x .132.....	.011
.145 x .119.....		.232 x .162.....	.011	.370 x .072.....	.019
.145 x .128.....		.232 x .180.....	.011	.370 x .100.....	.014
.150 x .035.....		.235 x .075.....	.019	.370 x .140.....	.010
.150 x .040.....		.235 x .085.....	.018	.370 x .250.....	.008
.150 x .100.....		.240 x .065.....	.017	.375 x .070.....	.019
.150 x .110.....		.250 x .050.....	.025	.375 x .090.....	.015
.155 x .080.....		.250 x .062.....	.021	.380 x .034.....	.035
.158 x .142.....		.250 x .069.....	.025	.400 x .029.....	.038
.160 x .100.....		.250 x .080.....	.021	.400 x .070.....	.019
.160 x .110.....		.250 x .093.....	.017	.400 x .085.....	.018
.162 x .127.....		.250 x .095.....	.017	.400 x .090.....	.015
.170 x .060.....		.250 x .100.....	.015	.400 x .110.....	.014
.170 x .075.....		.250 x .100.....	.015	.400 x .115.....	.013
.170 x .090.....		.250 x .125.....	.014	.400 x .140.....	.010
.170 x .100.....		.260 x .040.....	.030	.415 x .055.....	.026
.175 x .075.....		.260 x .060.....	.021	.420 x .095.....	.013
.175 x .100.....		.260 x .100.....	.017	.420 x .125.....	.011
.176 x .130.....		.265 x .185.....	.011	.450 x .120.....	.012
.178 x .157.....		.270 x .090.....	.016	.455 x .024.....	.060
.180 x .040.....		.275 x .110.....	.018	.460 x .070.....	.019
.180 x .045.....		.280 x .034.....	.032	.475 x .160.....	.013
.180 x .080.....		.280 x .080.....	.020	.500 x .090.....	.015
.183 x .077.....		.280 x .115.....	.014	.500 x .095.....	.013
.185 x .075.....		.280 x .120.....	.014	.500 x .100.....	.013
.185 x .090.....		.280 x .180.....	.012	.500 x .110.....	.012
.185 x .125.....		.282 x .063.....	.020	.500 x .120.....	.012
.187 x .050.....		.290 x .052.....	.026	.520 x .060.....	.021
.190 x .060.....		.290 x .084.....	.019	.535 x .085.....	.015
.190 x .145.....		.295 x .115.....	.014	.540 x .125.....	.011
.192 x .087.....		.300 x .050.....	.028	.550 x .100.....	.013
.200 x .020.....		.300 x .055.....	.026	.563 x .100.....	.013
.200 x .035.....		.300 x .080.....	.019	.570 x .125.....	.011
.200 x .086.....		.300 x .100.....	.014	.575 x .105.....	.012
		.300 x .107.....	.014	.650 x .105.....	.012

TO BLACKEN BRASS.

WIRE SOLDER.

A—Nitrate of silver, 120 grains; water, 5 ounces; B—Nitrate of copper, 120 grains; water, 5 ounces. Mix in equal quantities sufficient to cover the piece of metal which has to be blackened. Cleanse the brass of all grease in hot soda water and dip in the above solution, then heat it in an oven until black enough.

Tin, one part; lead, one part; bismuth, one-half part. Melt together and pour through a perforated dish onto a stone or metal slab, moving the dish along as the solder runs through and cools. Some prefer to use a funnel with a fine orifice instead of the perforated dish in pouring the solder on slab.



# MECHANICS FOR YOUNG AMERICA

## HOW TO MAKE A MINIATURE WINDMILL.

By A. Sheldon Pennoyer.

The following description is how a miniature windmill was made, which gave considerable power for its size, even in a light breeze. Its smaller parts, such as blades and pulleys, were constructed of 1-inch sugar pine on account of its softness.

The eight blades were made from pieces  $1 \times 1\frac{1}{2} \times 12$  inches. Two opposite edges were cut away until the blade was about  $\frac{1}{8}$  inch in thickness. Two inches were left uncut

keying the 5-inch pulley F, to shaft (G, Fig. 1) which extended to the ground. The  $2\frac{1}{2}$ -inch pulley, I, Fig. 1, was keyed to shaft C, as shown in Fig. 4. The wire L was put through the hole in the axle and the two ends curved so as to pass through the two holes in the pulley, after which they were given a final bend to keep the pulley in place. The method by which the shaft C was kept from working forward is shown in Fig. 5. M, the washer, intervened between the bearing block and the wire N, which was passed through the axle and then bent to prevent its falling out. Two wash-

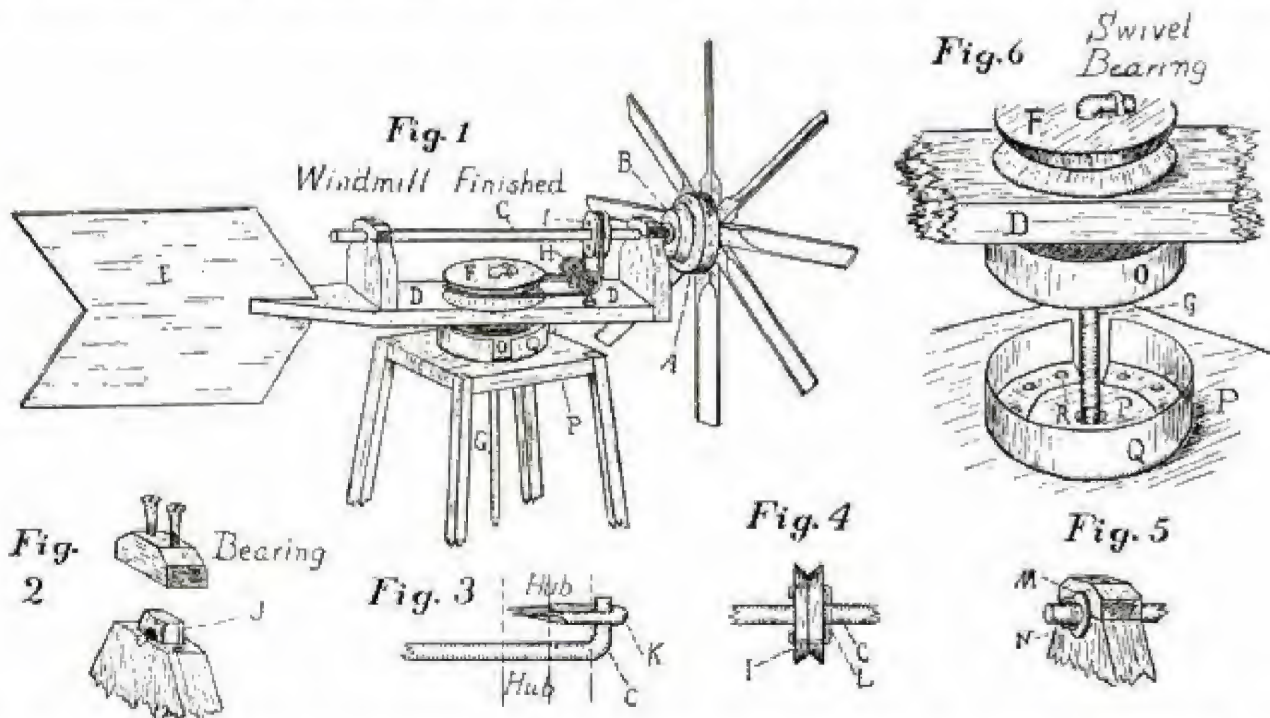

at the hub end. They were then nailed to the circular face plate A, Fig. 1, which was 6 inches in diameter and 1 inch thick. The center of the hub was lengthened by the wooden disk B, Fig. 1, which was nailed to the face plate. The shaft C, Fig. 1, was  $\frac{1}{4}$ -inch iron rod, 2 feet long, and turned in the bearings detailed in Fig. 2. J was a nut from a wagon bolt and was placed in the bearing to insure easy running. The bearing blocks were 3 inches wide, 1 inch thick and 3 inches high without the upper half. Both bearings were made in this manner.

Shaft C was keyed to the hub of the wheel, by the method shown in Fig. 3. K, a staple, held the shaft from revolving in the hub. This method was also applied in

ers were placed on shaft C, between the forward bearing and the hub of the wheel to lessen the friction.

The bed plate D, Fig. 1, was 2 feet long, 3 inches wide and 1 inch thick and was tapered from the rear bearing to the slot in which the fan E was nailed. This fan was made of  $\frac{1}{4}$ -inch pine  $18 \times 12$  inches and was cut the shape shown.

The two small iron pulleys with screw bases, H, Fig. 1, were obtained for a small sum from a hardware dealer. Their diameter was  $1\frac{1}{4}$  inches. The belt which transferred the power from shaft C to shaft G was top string, with a section of rubber in it to take up slack. To prevent it from slipping on the two wooden pulleys a rubber band was placed in the grooves of each.



The point for the swivel bearing was determined by balancing the bed plate, with all parts in place, across the thin edge of a board. There a  $\frac{1}{4}$ -inch hole was bored in which shaft G turned. To lessen the friction here, washers were placed under pulley F. The swivel bearing was made from two lids of baking powder cans. A section was cut out of one to permit its being enlarged enough to admit the other. The smaller one, O, Fig. 6, was nailed top down, with the sharp edge to the underside of the bed plate, so that the  $\frac{1}{4}$ -inch hole for shaft G was in the center. The other lid, G, was tacked, top down also, in the center of the board P, with brass headed furniture tacks, R, Fig. 6, which acted as a smooth surface for the other tin to revolve upon. Holes for shaft G were cut through both lids. Shaft G was but  $\frac{1}{4}$  inch in diameter, but to keep it from rubbing against the board P, a  $\frac{1}{2}$ -inch hole was bored for it, through the latter.

The tower was made of four 1 x 1 inch strips, 25 feet long. They converged from points on the ground forming an 8-foot square to the board P at the top of the tower. This board was 12 inches square and the corners were notched to admit the strips as shown, Fig. 1. Laths were nailed diagonally between the strips to strengthen the tower laterally. Each strip was screwed to a stake in the ground so that by disconnecting two of them the other two could be used as hinges and the tower could be tipped over and lowered to the ground, as, for instance, when the windmill needed oiling. Bearings for shaft G were placed 5 feet apart in the tower. The power was put to various uses.

### HOW TO BUILD AN ICE BOAT.

The season of the ice boat has arrived and this exciting sport is each year becoming more popular. Any one with even small experience in using tools can construct such a craft, and the pleasure many times repays the effort. One of the easiest ice boats to build is described in *Sail and Sweep* for November, as follows:

Take two pieces of wood 2x6, one 6 feet and the other 8 feet long. At each end of the 6-foot piece and at right angles to it, bolt a piece of hardwood 2x4x12 inches. Round off the lower edge of each piece to fit an old skate. Have a blacksmith bore holes through the top of the skates and screw one of them to each of the pieces of hardwood. These skates must be exactly



A Four-Runner Ice Yacht

parallel or there will be trouble the first time the craft is used.

Over the middle of the 6-foot piece and at right angles to it, bolt the 8-foot plank, leaving one foot projecting as in Fig. 1.

The rudder skate is fastened to a piece of hardwood 2x2x12 inches as the runners were fastened. This piece should be mortised 3x3x4 inches in the top before the skate is put on. Figure 2 shows the rudder post.

A piece of hardwood 1x6x6 inches should be screwed to the under side of the 8-foot plank at the end with the grain running crosswise. Through this bore a hole  $1\frac{1}{2}$  inches in diameter in order that the rudder post may fit nicely. The tiller, Fig. 3, should be of hardwood, and about 8 inches long.

To the under side of the 8-foot plank

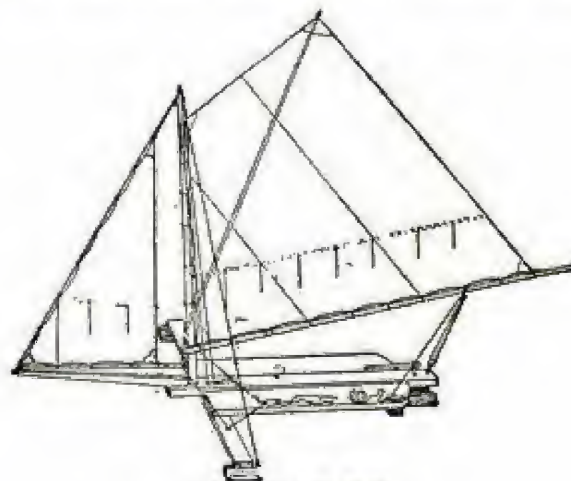

Plan of Ice Boat



bolt a piece of timber 2x4x22 inches in front of the rudder block, and to this cross-piece and the 6-foot plank nail 8-inch boards to make the platform.

The spar should be 9 feet long and 2½ inches in diameter at the base, tapering to

lin. Run the seam on a machine, put a stout cord in the hem and make loops at the corners.

Figure 6 shows the way of rigging the gaff to the spar. Figure 7 shows the method of crothing the main boom and

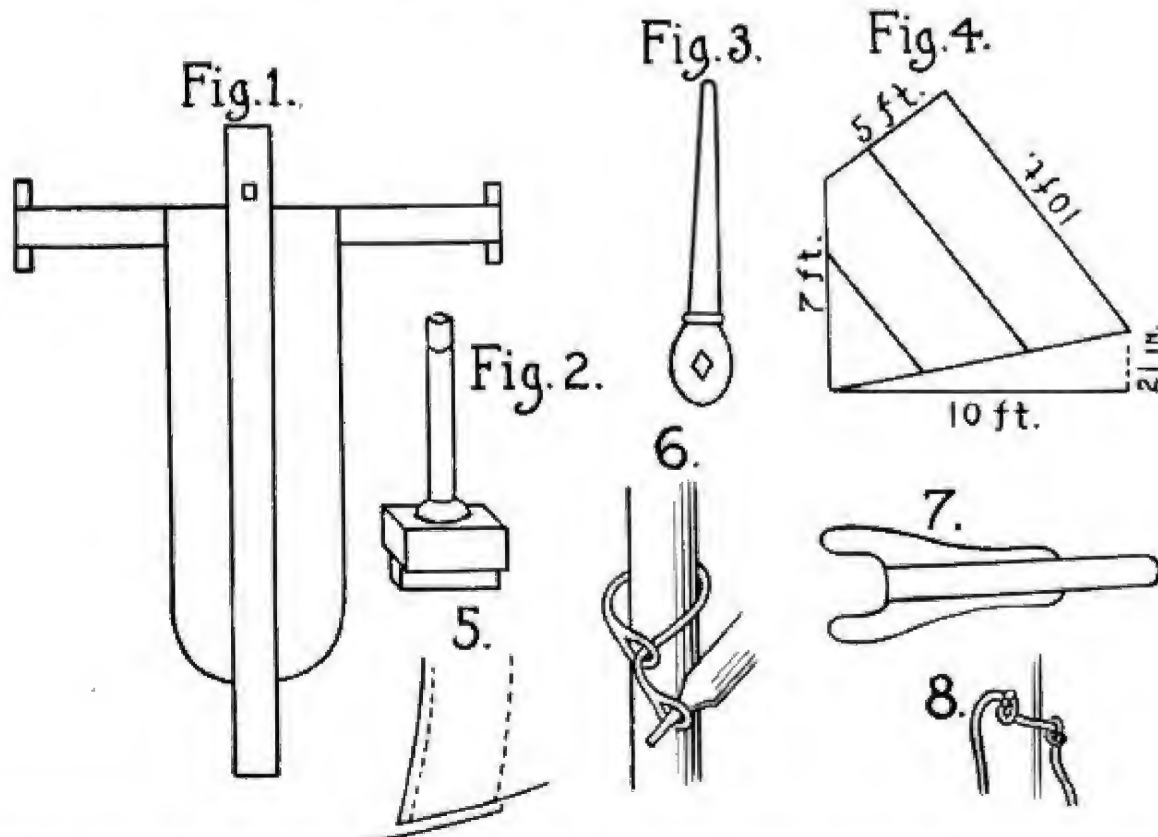

an inch and a half at the top. This fits in the square hole, Fig. 1. The horn should be 5½ feet long, 2x3 at the butt and 1 inch at the end.

Figure 4 gives the shape and dimensions of the mainsail which can be made of mus-

lin. Run the seam on a machine, put a stout cord in the hem and make loops at the corners.

Figure 6 shows the way of rigging the gaff to the spar. Figure 7 shows the method of crothing the main boom and

## Telegram From New York to Chicago Travels 24,000 Miles

### Who Can Tell How Long This Message Was in Going from Its Starting Point to Its Destination?

During the first terrific storm of the season which swept the East and cut off all communication between New York and western points, a little message, two words only, was sent from the New York stock exchange to LaSalle St., Chicago, by a new route, to be sure, but one which was wonderful in that every section of it was equal to the emergency. The message, "Market higher," first crossed the Atlantic from New York to London by cable, was wired to Suez, sent to Bombay, hurried to Hong-Kong and then to Yokohama, was

again cabled under a mighty ocean, this time the Pacific, via Honolulu to San Francisco, where the telegraph again took up its brief story and rushed it on to Chicago. By the same route the answer, "Give us something," was sent back. And on the two little messages there was more than \$50 cable tolls.

The message left the New York stock exchange at just 10 a. m. and arrived at LaSalle street, Chicago, at 11:45 a. m. Allowing for differences in time, how much time did its trip occupy?



## ORNAMENTAL METAL GUARDS FOR OPEN FIREPLACES AND HOW TO MAKE THEM.

The making of metal fire grate fronts has proven to be a very interesting and profitable occupation for boys in recent times. Not long ago it was sufficient for the ingenious youth to turn out juvenile windmills, toy houses and various little knickknacks for amusement. The modern lad wants more than this. He desires to turn some of his product into cash. Therefore we present some of the patterns of fire grates which boys have made and can make again from scrap iron, with few tools and devices, and find a ready market for the same as soon as they are made. Fig. 1 is a sketch of a form of fire grate bar or front that is constructed with a series of circles of strip metal. The best way is to go to the hardware store or iron dealers and buy a quantity of  $\frac{1}{4}$ -inch,  $\frac{1}{2}$ -inch and  $\frac{3}{4}$ -inch iron, about an  $\frac{1}{8}$  to  $\frac{3}{16}$ -inch thick. In fact, 1-16-inch metal would do in many cases where the parts are worked out small in size. The  $\frac{1}{2}$ -inch metal is very strong. Then after getting the supply of strip metal in stock, procure the usual type of metal worker's hammer, a cheap anvil, a 9-pound vise, a cold chisel, a file or two, and a round piece of shaft iron, about 3 inches diameter and 2 to 3 feet long. This piece of iron is represented at B, Fig. 2.

The iron is held in position by means of the straps of metal C, C, which are bent over the shaft tightly and grip the board base with set or lag screws as shown. The wooden base should be about 2 inches thick and large enough to make a good support for the iron shaft. The process of bending the rings in this way is as shown. The piece of strip iron is grasped at D. Then with the hammer the iron is gradually worked cold about the mandrel as at E until the perfect form is acquired. After the form is finished, the strip at the terminus of the ring is cut off. In order to get a steady base the wooden part may be bolted to a bench. In Fig. 3 is shown the method of clipping off the completed ring. The cold chisel is held upright, and by delivering several blows with the hammer upon the same, the point is caused to chip through the metal and release the ring. The shaft or mandrel is marked G. The cold chisel is indicated at I and the position where the hand grasps the strip is at H. The final operation in

shaping the ring is by driving the protruding cut, lip down, to the common level of the opposite point, thus giving us the finished ring with the lips closed on the mandrel as at J, Fig. 4. These rings can be turned out in this way very speedily. The next operation involves the process of uniting the rings in the plan to shape the design. The design work is often worked out ahead and followed. Some become so proficient that they can develop a design as they proceed.

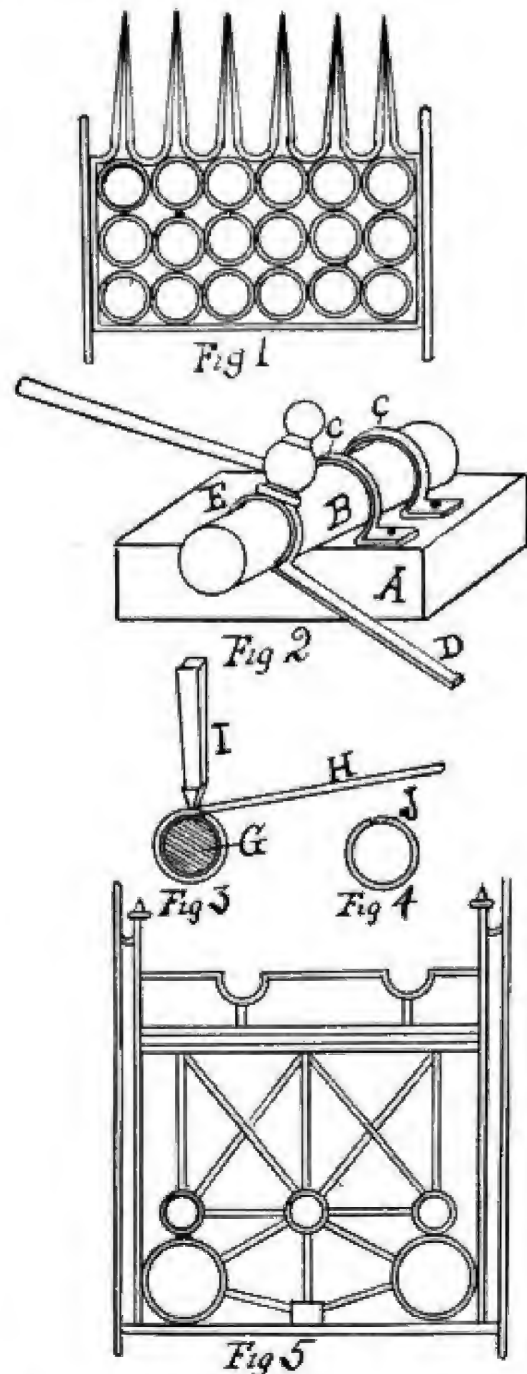

Fig. 1 is a design of grate front used for various purposes in connection with grate fires. The series of rings are united by a rivet between each at the joining point. With thin metal the holes can be punched



with an iron punch and hammer on an anvil where there is a hole to receive the point of the punch after the punch penetrates the metal. For the heavier forms of metal a drill is necessary. A metal drill and brace can be purchased very cheaply for this work. After drilling the holes, the parts are erected and the rivets inserted and

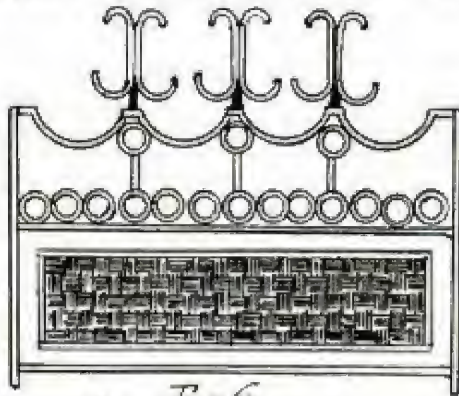

Fig 6

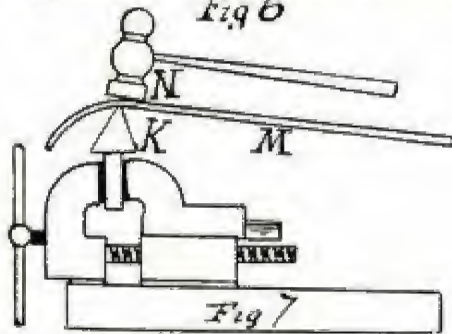

Fig 7

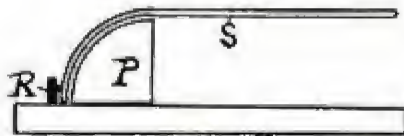

Fig 8

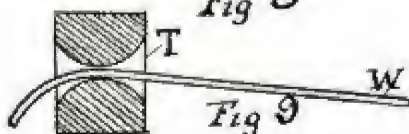

Fig 9

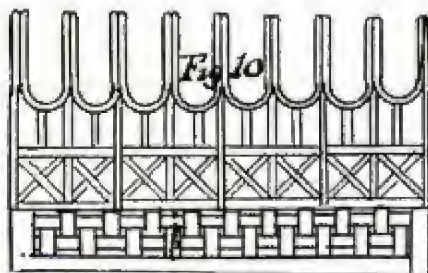

Fig 10

beaded up as each addition is made. Thus the series of rings are united and then the side pieces are similarly riveted. The points at the top are then worked out and joined on. These points are filed down to the necessary taper after the union is effected. The finishing work involves smoothing rough places with a file and painting. Asphaltum makes a good black finish. Some of the best designs of grates are bronzed.

Some are silvered. The different designs are finished as desired by customers.

Fig. 5 is another design of grate in which the process of shaping the rings is like that in the first design. There are some half circles in this pattern and these are framed by shaping the same about the mandrel with the hammer. In order to get the shoulders close and the circle complete it is necessary to heat the metal. A coke fire can be made in a hole in the ground. Then procure a tin blowpipe and blow the flame against the metal at the point to be bent. This metal will become red hot very soon, and can be bent readily against the anvil and the circular form. Let the metal cool off on the ground after heating. Fig. 6 is another design which can be wrought out. The middle adjustment is wire screen work which may be bought at a hardware store and set into the position shown. Fig. 7 shows a chipping off device useful in connection with this work. Metal chippers can be bought at any tool store. The chipper is placed in the jaws of the vise as at K, and secured there. The strip of metal in process of cutting is marked M. The hammer head is caused to strike the metal just over the cutting edge of the chipper. The quick, hard blow causes the cutting edge to penetrate far enough to sever the piece. Bending cold with a wooden form is done as in Fig. 8. The wooden form is marked P and is about 8 inches wide and 7 inches high, forming a one-sided oval shape. There is a pin R set into the base board of the oval form and the strip of metal for bending is grasped at S and the other end is inserted back of the pin R. By applying pressure, the strip of metal is bent to the form.

Fig. 9 shows the hour-glass wood bending form, made by selecting a piece of hard wood block, about 6 inches square and boring through with an inch bit. Then the hole is shaped hour-glass like. The view is a sectional one. The block is placed in a vise and the strip for bending is inserted as at T.

The strip of metal is grasped at W and can be bent to various forms by exerting pressure. Fig. 10 is another type of fire-place front, constructed by uniting the shaped metal pieces. In fact an almost endless variety of designs can be wrought out after the start is once made. A good way to figure the price on the grate is to add up the costs of the parts and charge about 12 cents per hour for the work.



# That Strangers May Know I Offer a Dollar's Worth Free

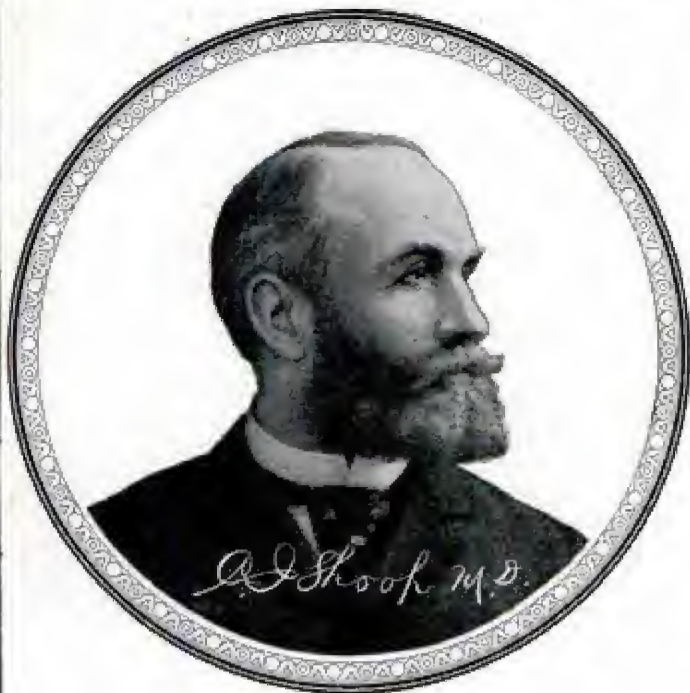

I know of a remedy for certain forms of illness that brings the utmost relief that medicine can. I am so sure of it that to any ailing one who has not tried it, I will willingly give a full dollar's worth free to test.

My offer is born of confidence unlimited. I ask no deposit—no promise. There is nothing to pay, either now or later. The dollar bottle is free.

Mine is no ordinary remedy. It represents thirty years of experiment—thirty years at bed-sides—in laboratories—at hospitals. Thirty years of the richest experience a physician can have. I tell below wherein my remedy differs, radically, from other medicines.

My offer is as broad as humanity itself. For sickness knows no distinction in its ravages. And the restless patient on a downy couch is no more welcome than the wasting sufferer who frets through the lagging hours in a dismal hovel.

I want no reference—no security. The poor have the same opportunity as the rich.—To, one and all I say "Merely write and ask." I will send you an order on your druggist. He will give you free, the full dollar package.

## Inside Nerves!

Only one out of every 98 has perfect health. Of the 97 sick ones, some are bed-ridden, some are half sick, and some are only dull and listless. But most of the sickness comes from a common cause. The nerves are weak. Not the nerves you ordinarily think about—not the nerves that govern your movements and your thoughts.

But the nerves that, unguided and unknown, night and day, keep your heart in motion—control your digestive apparatus—regulate your liver—operate your kidneys.

These are the nerves that wear out and break down.

It does no good to treat the ailing organ—the irregular heart—the disordered liver—the rebellious stomach—the deranged kidneys. They are not to blame. But go back to the nerves that control them. There you will find the seat of the trouble.

There is nothing new about this—nothing any physician would dispute. But it remained for Dr. Shoop to apply this knowledge—to put it to practical use. Dr. Shoop's Restorative is the result of a quarter century of endeavor along this very line. It does not dose the organ or deaden the pain—but it does go at once to the nerve—the inside nerve—the power nerve—and builds it up, and strengthens it and makes it well.

## Many Ailments—One Cure

I have called these the inside nerves for simplicity's sake. Their usual name is the "sympathetic" nerves. Physicians call them by this name because each is in close sympathy with the others. The result is that when one branch is allowed to become impaired, the others weaken. That is why one kind of sickness leads into another. That is why cases become "complicated." For this delicate nerve is the most sensitive part of the human system.

Does this not explain to you some of the uncertainties of medicine—is not a good reason to your mind why other kinds of treatment may have failed?

Don't you see that THIS is NEW in medicine? That this is NOT the mere patchwork of a stimulant—the mere soothing of a narcotic? Don't you see that it goes right to the root of the trouble and eradicates the cause?

But I do not ask you to take a single statement of mine—I do not ask you to believe a word I say until you have tried my medicine in your own home at my expense, absolutely. Could I offer you a full dollar's worth free if there were any misrepresentation? Could I let you go to your druggist—whom you know—and pick out any bottle he has on his shelves of my medicine were it not UNIFORMLY helpful? Could I AFFORD to do this if I were not reasonably SURE that my medicine will help you?

## Simply Write Me

The first free bottle may be enough to effect a cure—but I do not promise that. Nor do I fear a loss of possible profit if it does. For such a test will surely convince the cured one beyond doubt, or disbelief, that every word I say is true.

The offer is open to everyone, everywhere. But you must write ME for the free dollar bottle order. All druggists do not grant the test. I will then direct you to one that does. He will pass it down to you from his stock as freely as though your dollar laid before him. Write for the order today. The offer may not remain open. I will send you the book you ask for beside. It is free. It will help you to understand your case. What more can I do to convince you of my interest—of my sincerity?

For a free order for a full dollar bottle address  
Dr. Shoop,  
6x4953 Racine,  
Wis. State  
which book  
you want.

Book 1 on Dyspepsia.  
Book 2 on the Heart.  
Book 3 on the Kidneys.  
Book 4 for Women.  
Book 5 for Men.  
Book 6 on Rheumatism.

Mild cases, are often cured with one or two bottles. For sale at forty thousand drug stores.

# Dr. Shoop's Restorative



## HISTORY OF IRON WORKING.

Read before the National Railroad Master Blacksmiths' Association by W. W. McLellan, of Denver, Colo.]

I might theorize on iron from the atom, that we cannot see, to the mountains of ore that rear their heads toward the clouds. But this is not necessary. Suffice it to say it is the most generally diffused ore on the earth's surface. It accommodates itself to our wants and desires. It is equally serviceable in the arts and sciences; in peace and war. The same ore furulshes the sword for the soldier and the plowshare for the farmer; the anchor and chains that enable the navies of the world to ride in safety through the heaviest gale; and the monster cannon that sends with lightning speed its death-dealing messenger of steel to destroy them. Without its use the praises now so universally sung of Columbus would never have taken voice. For Columbus with all his will-power and religious enthusiasm would not have attempted to travel a breakless ocean without the aid of a mariner's compass, for which no other metal has been found to



First Iron Furnace in Ohio.

accomplish what its almost living, moving finger of iron has done. And the most distinguished scientists say that it is the only metal that is friendly to the human frame. And so general has its use become that we have been for several years the largest users of iron and steel in the world, our consumption per capita averaging 220 lb. for each man, woman and child in the United States. The history of a metal so generally used and of such value must be of interest.

I cannot claim for it an American origin. For its early history we must go back to the birthplace of the human race. Asia and the northern parts of Africa, near Asia, where Tubal-Cain, the seventh in generation from Adam, we are told in the Book of Genesis, was an instructor of every artificer in iron, or, as we would say nowadays, the first foreman blacksmith. From this we may reasonably suppose that it is here that iron was first manufactured and used for practical purposes.

The Egyptians, whose existence as a nation dates from the second generation after Noah, were familiar with its manufacture and use.

Herodotus tells of the iron tools used in the construction of the Pyramids. From the ruins of Memphis and Thebes, cities so old that their origin has been lost in the mist of the past, have been taken from where they must have lain for 3,000 years some of the finest specimens of early iron to be found in the British museum.

The use of iron and the art of manufacture was

carried on at a very early day in the southern and western portion of Arabia. It is likely that they derived their knowledge from the Egyptians, for the ruins of extensive iron works of undoubted Egyptian origin were discovered near the wells of Moses on the Peninsula of Sinal as late as 1873. Iron was known to the Chaldeans, Babylonians and Assyrians contemporary of the early Egyptians. Chaldean inscriptions show that iron was known to the most ancient of Mesopotamia. In the ruins of Nemea many articles of iron have been found, together with inscriptions of its uses. In the British museum there is a saw and pick taken from these ruins.

The Book of Job, supposed to relate to a period between Abraham and Moses, has many references to iron; yes, even to bars of iron. For many years I had fondly held the hope that the pan was certainly an American invention, but we find Job speaking of it prior to the time of Moses.

Perhaps Solomon was right when he said there is nothing new under the sun. After the Israelites came into the Promised Land, frequent mention is made of iron and its use in agriculture and for weapons of war. Those who are conversant with Bible history will recollect that in describing the armor of Goliath it is said that his spearhead weighed 600 shekels of iron (about 19 pounds).

Axes, saws and harrows of iron are mentioned in the time of David, and axes, hammers and tools of iron in the reign of Solomon. In Ecclesiastes we read that if the iron be blunt and he do not whet the edge, then must he put to more strength. We could not describe a dull chisel better to-day. A thousand years before Christ, David, prior to building the temple, secured iron nails for the doors and gates, and in his instructions to his son Solomon he says that he had iron in abundance. While realizing its value, it is an open question whether or not the Israelites were workers of iron, for we read that Solomon sent to Hiram, King of Tyre, for a man cunning to work iron. The Chaldeans were famous for the fine quality of their iron and steel. Herodotus, in the fifth century, before Christ, speaks of them as a nation of iron workers. The Persians, long before the Christian era, were workers of iron, and no man could be king who had not forged and tempered his own weapons of war. Iron and steel of a very fine quality are still made in Persia.

India, at a very early period, was acquainted with its manufacture. When Alexander defeated Poras, one of the Pongah kings, in the fourth century, before the Christian era, Poras gave him as a ransom thirty pounds of steel. The steel at that time made is unsurpassed to-day. The Damascus blade is, as it was 1,000 years ago, the equal of the best in the world. That the natives of India excelled in the forging of iron, as well as the working and tempering of steel, is easy of proof, for to-day, at the principal gate at the temple of Kartah, near Della, stands a wrought-iron pillar sixty feet high, sixteen feet at the base, and weighing over seventeen tons. An inscription in Sanskrit assigns its erection to the tenth century before Christ. In the ruins of Indian temples have been found wrought-iron beams similar in size and appearance to those used in the present day.

How those people who appear not to have had any of our modern appliances for handling such

(Continued on page 160)





# ELECTRIC LIGHTS

RICHARDSON ENGINEERING CO.  
36 PEARL STREET HARTFORD, CONN. U.S.A.



**SIMPLE  
RELIABLE  
PRACTICAL**

**No Electrician  
Needed to Install  
or Operate**

**Large Outfits  
for Any Size Place,  
Launch or Yacht**

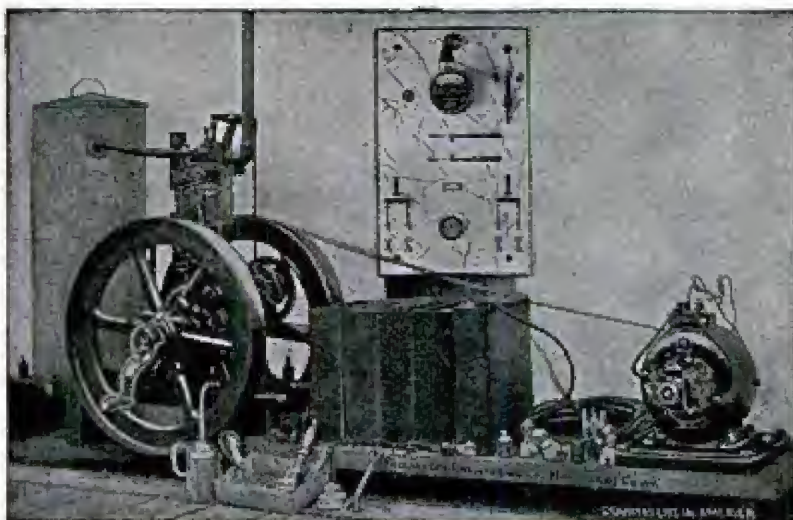

**ALL OUR  
OUTFITS COM-  
PLETE IN  
EVERY DETAIL**

**Very Best  
Material  
Used**

**Light all the Time  
as Every  
Outfit Includes a  
Storage Battery**

NO. 3. 30-LIGHT OUTFIT FOR MOUNTAIN AND SHORE

**COTTAGES OR SMALL HOMES, \$450, EVERYTHING INCLUDED. OTHER SIZES TO \$1,800**

THE GAS, GASOLINE OR STEAM ENGINES FURNISHED GIVE PLENTY OF POWER FOR SAWING WOOD, PUMPING WATER, REFRIGERATION, ICE MAKING, ETC.

FOR INTERESTING AND VALUABLE PRINTED MATTER. ADDRESS

Electric Light Dept. **RICHARDSON ENGINEERING CO.**, Hartford, Conn.

# STARRETT TOOLS



are the recognized standard for accuracy, workmanship, design and finish. Whether you use tools to earn your daily bread or for amusement and relaxation from a different vocation, it pays to use GOOD tools. You get a better quality of bread and a good deal more pleasure.

## USE STARRETT TOOLS

We make hundreds of different tools. Ours is the largest plant in the world where nothing but fine mechanical tools are made. All these tools are fully described and illustrated in our Catalogue No. 17AP, which you may have by sending us your address. There is a good deal of valuable information in its 176 pages which it will pay anyone who uses tools

to have.

**THE L. S. STARRETT COMPANY**  
ATHOL, MASS., U. S. A.



L. S. STARRETT



# THE IDEAL SIGHT RESTORER



**WE RESTORE SIGHT!**  
**CLASSES RENDER DEFECTIVE VISION CHRONIC.**  
 Write for our **ILLUSTRATED TREATISE, Mailed Free.**  
**THE IDEAL COMPANY, 239 BROADWAY, NEW YORK.**



(Continued from page 158.)

large bodies of metal could have forged them is a question yet unsolved.

The period in which its manufacture was begun in China is uncertain. But P'ling, the elder, who wrote in the first century of the Christian era, says that none shall match in goodness the steel that cometh from China. We proudly speak of this as the age of iron and steel. And yet, through its use principally we think Asia, Africa and Egypt became the wealthiest nations of antiquity. But, as they ceased to manufacture iron, their civilization and magnificence faded. Egypt, for 2,000 years, has not made iron, and in all Asia and Africa there is probably less iron and steel made than on her borders twenty-five centuries ago, when Babylon was the glory of kingdoms, the beauty of the Chaldean excellency.

From Asia the manufacture of iron spread to Europe. The first authentic history of the use of iron dates from about 776 years before the Christian era. But the poetry, fables and mythology of the Greeks have transmitted to us many references to iron long prior to this date.

It was claimed that the burning of the forests on Mount Ida, in Creta, accidentally communicated to the inhabitants the art of obtaining iron from the native ores. This, like the story of Vulcanus and his famous forges on the island of Lemnus, may be fabulous, but the metal was so valuable that the people ascribed its manufacture to the gods.

The poems of Homer, claimed to have been written prior to the era of authentic Grecian history, make frequent mention of iron, and the art of hardening and tempering is fully described in reference to the plunging of Ulysses' fire-brand into the eyes of Polyphemus, an act likened to that of

the smith who plunges the loud, hissing axe into cold water to temper it, and add, "For hence is the strength of iron" But it must have been comparatively scarce and valuable. For at the celebrated games of the Greeks we read that Achilles, in an address to the competitors, holding a piece of iron in his hand, says:

"Stand forth who ere will for this contend, and if broad fields and riches be his, this mass will last him many years. The man who tends his flock or guides his plow need not be sent to town for iron, he will have it here."

At a later date "Lycurgus" allowed nothing but bars of iron to pass for money. Shortly after this they worked the iron bars up into quoits, and he who in the games lost his quoits lost his fortune.

During the time of "Sophocles," about four and one-half centuries before Christ, the Greeks turned their knowledge of the working of iron and steel to the forging of weapons of war, notably the sword, and we are told that the father of Demosthenes, the greatest of Grecian orators, was a blacksmith who made swords.

About this time the Mediterranean country had discarded the bronze weapons and adopted steel. During the next 100 years great strides must have been made in the use of iron, for in a description of one of the war ships built by Archimedes for King Heiro of Syracuse, we are told that to each of the three masts were attached engines which darted iron bars and masses of lead against the enemy. The sides of the ship bristled with iron spikes, and of the twelve anchors, eight were iron. The Greeks were great teachers, and the early Romans were among her pupils. We read that in one of the early wars between the Romans and the Etruscans, among the conditions exacted by the victorious Etruscan king was prohibiting the



**HAVE YOU ANY USE FOR A BUGGY?** If you have, don't fail to cut this ad. out today and mail to us. If you can't use a top buggy at any price, call your neighbor's attention to this announcement. Don't buy any kind of a buggy until after you cut this ad. out and send to us and get the **FOUR BIG FREE CATALOGUES**, the most liberal offer, the very latest proposition, everything explained, all free for the asking. **WRITE TODAY. ADDRESS, SEARS, ROEBUCK & CO., Chicago, Ill.**

## \$21.00 PRICE EXPLAINED

**FOR \$21.00 TO \$23.00** | **ALSO ROAD WAGONS AT \$14.00 TO \$17.00**  
**SURREYS AT \$34.00 TO \$38.00**

**TOP BUGGIES**, similar to one illustrated, **HAVE BEEN WIDELY ADVERTISED.**  
**HOW BUGGIES** can be offered at these prices and why we can sell buggies and all other vehicles at much lower prices than any other house is all fully explained in our **FOUR BIG FREE VEHICLE CATALOGUES**. Cut this ad out and send to us and you will receive by return mail, **Free, Postpaid, FOUR BIG VEHICLE CATALOGUES** showing the most complete line of everything in Buggies, Road Wagons, Carts, Surreys, Phaetons, Carriages, Light and Heavy Wagons, Vehicles of all kinds, also all kinds of Harness, Saddles and Saddlery, all shown in large handsome half-tone illustrations, full descriptions and all priced at **PRICES MUCH LOWER THAN ANY OTHER HOUSE CAN POSSIBLY MAKE.**  
**WITH THE FOUR FREE CATALOGUES** you will receive the most astonishing Buggy Offer ever heard of, a new and astonishing proposition. How others can offer top buggies at \$21.00 to \$23.00 and why we can sell at much lower prices than all others will be fully explained. We will explain why we ship so as to make freight charges amount to next to nothing. We will explain why we are the only makers or dealers in the world that can ship buggies the day we receive your order. Our free trial offer, our pay after received terms, our bidding guarantee are all explained when we send you the **Four Free Catalogues**.



Romans from using iron except for agricultural purposes.

As late as 300 years before Christ, when Rome was about to be ransomed by the Gauls by a large payment of gold, Camilleons, the dictator, demanded, saying that Rome should be ransomed with iron and not with gold. Were he living in the west or south to-day we would be safe in claiming that he would favor the free and unlimited coinage of silver at a ratio of 16 to 1.

The Romans, in extending the arts of their advanced civilization, gave special encouragement to the making of iron and steel. Spain, that for 200 years past has been staggering backward under her load of debt and superstition, was, during the time she manufactured iron, the strongest and haughtiest queen among the nations.

Toledo was famous for its swords prior to its occupation by the Romans. The iron industry of Spain was the first in the world, and for some hundreds of years after the Romans obtained a foothold, its prominence survived the downfall of the Roman power and flourished under the subsequent rule of the Visigoths.

The Moors, who became masters of the greater part of Spain at the beginning of the eighth century of the Christian era, were noted manufacturers of iron and their workmen were eagerly sought after by France and Germany.

France made slow progress in the making of iron, perhaps owing to the fact that her ores were poor in comparison with those of Spain, near by.

Iron was used at a very early date in Britannia, for Julius Caesar, in speaking of the inhabitants of the southern part of Britannia, says their anchors were fastened with iron chains, and that the benches of these vessels, on which the rowers sat, were fastened with iron spikes of the thickness of a man's thumb.

When William, the Norman, invaded England he was accompanied by many men who were armorers and skilled workers in iron.

The Germans were a little late in adopting iron for weapons of war, and at a time when other nations realized its value, our German friends, like some of our friends of the present day, went to battle with a wooden club. However, she is no longer slow.

The iron industry in Sweden existed as early as the thirteenth century, at which date one of the Knudsons was a noted iron worker.

In Russia we first hear of it in 1569, at which time the English obtained the privilege of seeking for and smelting iron ores on condition that they should teach the Russians the art of working the metal. They were apt scholars for many years. They have produced a sheet iron considered superior to that made by any other nation.

The manufacturing of iron by the Britains prior to the Roman invasion is in doubt, but the Romans during their occupancy increased it. Large heaps of cinders, old as the Roman era, have been found in many parts of England, once occupied by the Romans. But it must have made slow progress, for in 1317 the Scotch would start out on a predatory expedition to steal iron, as their descendants would start out some hundred years later to steal cattle. In both cases they were generally successful.

Smiles says England owes much to iron workers. In Anglo-Saxon times they were treated as officers of the highest rank; their persons were protected by a double penalty. He who killed an iron worker was first hung and then quartered. I am afraid that with the knowledge some of you have of iron workers you may think such punishment a little severe. William the Conqueror was their especial patron, he going so far as to say that the battle of Hastings was won with the good swords they had made him.

(Continued on page 162.)

# Reduced to 2½ h. p. \$96 "Little Giant" GASOLINE ENGINE

A Safer, Better or More Satisfactory Engine of Equal Power was never Built.



Our Former Price \$105.00  
Agent's Price \$125.00 and up

## Don't Buy Any Engine

until you have fully investigated the merits of this excellent "Little Giant." We can satisfy you at a saving of one-quarter. WRITE TODAY FOR ENGINE CATALOGUE. Sent gratis.

**Montgomery Ward & Co.**  
CHICAGO

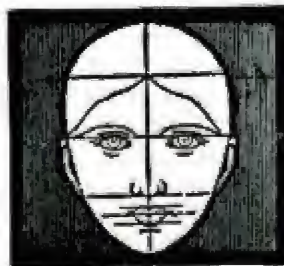

"HOW TO ILLUSTRATE" \$1.00  
AND  
"ART OF CARICATURE" \$.50

Teach thoroughly drawing and illustrating, in all its branches. Price, both books, \$1.25 post-paid. 16 pg. illus. cat'g on request.

BROWN PUBLISHING CO.,  
Room 909 114 Fifth Ave., New York.





# Dynamo and Motor Bargains

We carry in stock over 600 machines in all sizes from  $\frac{1}{8}$  to 100 horse power, both new and second hand, all guaranteed. Small factory equipments our specialty.

NO ONE

Can sell you a first-class machine for less money. We repair all makes. Send us your inquiries.

## Guarantee Electric Co.

CHAS. E. GREGORY, Pres.

153 to 159 S. Clinton St.,

CHICAGO



**WE CAN KILL THOSE  
IGNITION TROUBLES**

**DURO BATTERIES ARE THE MOST  
DURABLE, COMPACT and EFFICIENT**

The Only Way of Obtaining a Mileage Guarantee

**Chicago Battery Co.**

1421 Michigan Avenue, Chicago

During the latter part of the fourteenth and during the fifteenth century, the wrought-iron work produced surpasses in beauty of design and elegance of finish anything of the present day.

Previous to 1746 charcoal had been universally employed in making iron, but at this date the first coke furnace was built in England. With the adopting of coke from mineral coal for smelting ore, commenced the wonderful progress that has been going on for 150 years past. Perhaps the most important matter of the eighteenth century was the attention paid to machinery as a substitute for hand labor. England, quick to appreciate the value of labor-saving machinery, very soon took first place as the chief manufacturing nation of the world. An American writer says to England and Scotland is the world indebted for the inventions that gave fresh impetus to the making of iron in the eighteenth century. Darby, Smeaton and Cort were Englishmen, Watt a Scotchman.

And it is further indebted to the same countries for most of the inventions of the present century that have cheapened iron and made steel almost universal. Stephenson, the Englishman, improved the locomotive in 1815. In 1825 the first passenger railroad was opened in England, Stephenson's locomotive pulling the train. Neilson, a Scotchman, invented the hot blast; Nasmyth, the steam hammers, and Bessemer, the Englishman, invented the process that bears his name, and which is to-day the flower of meteorological achievements.

We will now in a hurried manner sketch the history of iron in the United States.

North Carolina first gave to Europeans the knowledge that iron ore existed within the limits of the new world. The discovery was made in 1585 by Ralph Lane, the leader of that first expedition that attempted to plant an English settlement on the Atlantic coast. The historian of the expedition says: "We found near the water side the ground to be rocky, which, on examination by a mineral man, was found to hold rich iron ore."

No attempt was made to utilize the discovery and iron had been made in many of the other colonies before it was first made in North Carolina.

On the 10th day of April, 1608, a ship owned by the Virginia Company of London, commanded by Captain Christopher Newport, sailed from Jamestown. She was loaded with sassafras, cedar posts, walnut logs and "cause of joy to the world," the balance of her cargo was iron ore. Forty days after she arrived in England, where the ore was smelted and the product, seventeen tons, was sold at £4 per ton to the East India Company and by them shipped to India. Is it not a little strange that the first iron produced from the ore of the new world should have been sent to almost the first place in the old world where its history commenced?

A few years later, in 1619, the Virginia Company of London sent John Beverley with a number of skilled workmen to Virginia to erect iron works and develop the ore deposits. They were ready to start up when, on the 22d of March, 1622, the Indian massacre took place. Beverley and his companions were all killed, the works were destroyed and thus ended disastrously the first attempt to make iron in America. It was not until the eighteenth century that Virginia fulfilled the expectation entertained of its iron producing capacities by the enterprising, but felled, Virginia Company of London.

Near the present city of Lynn, Mass., then the Province of Massachusetts Bay, in 1643, were established the first successful iron works in the new world. Governor Winthrop was a leading spirit in the enterprise. Their capacity was about a ton a day. But owing to an overflow from their dams and a fear on the part of the settlers that they would cause a scarcity of timber, the company was involved in frequent litigation. So that instead of drawing out iron for the country's use, there was hammered out nothing but lawsuits, which eventually caused



them to cease work. So thus again ended in financial failure the efforts of the second London Company to make iron in America. Before leaving this pioneer let me say that the first iron casting made in the new world was made at this furnace. It was a small iron pot, but capable of holding about a quart. It has been handed down as a family heirloom. A few years ago when I visited Boston it was on exhibition at the old South Church.

I am patriotic enough to say that I felt more pride in drinking water from this old iron cup, handed me by a New England mother, than I would had I drank the rarest wine from the golden goblet of a king. Two hundred and forty-one years ago, October, 1653, the settlers of Massachusetts Bay had begun to regard themselves as New Englanders. The heaven of independence had begun its work, for we read that on the first of October, 1662, a town meeting was held at Taunton, the result of which was the starting of the Rayhan Blomary, afterward well known as the Leonard iron works, which were so well managed that in 1865, or for a period of 200 years, they were still in successful operation, and conducted by the descendants of the original owners. I am sorry to say that now these works, the oldest iron works of the new world, are in a dilapidated condition.

I think of them as a shrine where the iron workers of America, and, in fact, all good citizens should turn, and if they do not worship they should at least admire the genius of those noble men who successfully blazoned an iron road on which we are traveling to national greatness.

#### THE TROUBLED MAN.

He looked like a man who would be sure to overturn the first plank he came to if he thought there might be trouble under it, and his looks probably didn't do him an injustice, for he deliberately went into the smoking car, when there were plenty of seats in the coaches. Sitting down behind a man whose head showed but little above the back of the seat and who was so busy puffing at a cigar that he had not looked around, the trouble hunter mopped his brow and looked as if he regarded it as an insult to him personally that the weather was so hot. He apparently had no intention of smoking, and his expression clearly indicated that he couldn't quite understand why the other men in the car had not put up their pipes and thrown away their cigars when he entered. A whiff of smoke emitted by the occupant of the seat in front was wafted back, and he screwed up his countenance horribly, at the same time waving his arms as if he had been a windmill.

A moment later there was a further output from the man in front, and the gentleman with the grievance gave up trying to be patient.

"Look here," he said, tapping his tormentor—not very gently—on the back of the head, "your smoke is blowing in my face."

"Is it?" the man in front asked, permitting his head to roll over on the side, so that he could obtain a one-eyed glimpse of the aggrieved person, "I wish it wouldn't."

He resumed his former comfortable position and went on smoking. Presently another whiff was swept backward.

"Say," protested the one with the unhappy look, "your smoke's blowing back here again."

"If there's a judge aboard you might get an injunction."

"Is that the way you answer a gentleman?"

"No."

"Well, I demand an apology."

"All right."

"But it isn't all right. Your smoke's blowing in my face."

The man in front sat up. When he did so a pair of broad, strong shoulders came into view, and

(Continued on page 164.)

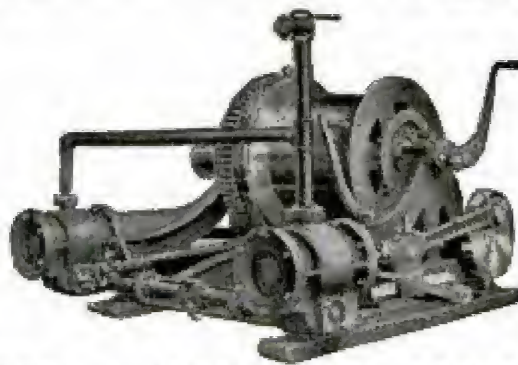

## THE QUINCY HOIST

8 x 10 Cylinders, Drum 14 x 20,	\$498
8 x 10 Cylinders, Drum 24 x 24,	\$505
8 x 10 Cylinders, Drum 30 x 30,	\$525

**YOUR CHOICE; FRICTION OR REVERSIBLE**

Delivery f. o. b. Quincy, Ill., or Chicago

No discount from above prices.  
Will ship subject to inspection and approval.  
Modern, Quick, Strong, Efficient. Just the thing for pulling up cars or for small mines. Got 'em in stock. Order one.

**WILLIS SHAW, - - Chicago**  
SOLE DISTRIBUTOR

## The American Well Wks.

AURORA, ILL., U. S. A.

CHICAGO, ILL.

DALLAS, TEX.

For over a quarter of a century have been building WELL SINKING and PROSPECTING MACHINERY and TOOLS for ROCK and ALLUVIAL, ROTARY and CORING WORK of moderate cost, speedy economical in operation, enabling large per cent saving in pay roll and pipe bills.

This photograph may not illustrate the style of machine best suited to your work, but we have one hundred other styles and sizes some of which will. Why should we not have your orders?

We have pleased old customers, can please new ones.

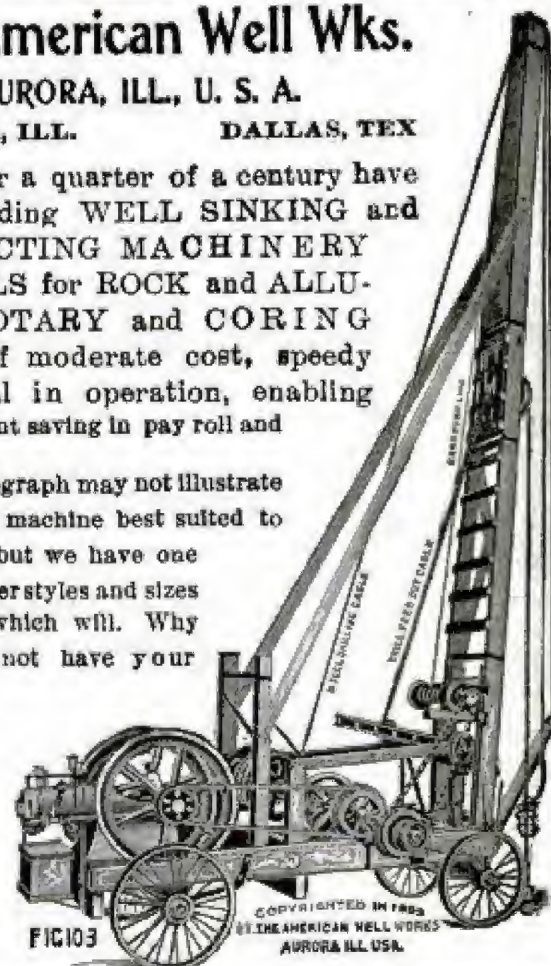
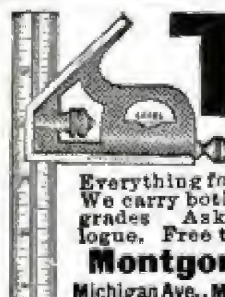

FIG 103

COPYRIGHTED IN 1903  
BY THE AMERICAN WELL WORKS  
AURORA ILL. U.S.A.



## Tools

Every mechanic should have a copy of our large 600 page catalogue in his tool kit. The largest retail hardware stock in the world at your command.

Everything for all trades at wholesale prices. We carry both the medium and the very best grades. Ask for 600 page Mechanics Catalogue. Free to any address.

**Montgomery Ward & Co.**  
Michigan Ave., Madison and Washington Sts., Chicago



# "HASTINGS" Compound for Dynamos and Motors

POCKET SIZE, 60 CENTS

Money refunded if it don't do the work. This is the only compound sold with a guarantee.

JAS. L. NEEFUS, Sole Agent,

45 Dey St., New York City

## "WE ANALYSE EVERYTHING"

AT REASONABLE RATES

Should you want to know what is contained in any preparation or product, address

**THE ELLSWORTH LABORATORIES**

MAX D. SLIMMER, Ph. D.

357 DEARBORN STREET, - - CHICAGO

## NEW AND SECOND-HAND ELECTRICAL MACHINERY

COMPLETE PLANTS INSTALLED.

Expert Electrical Repairers of Armatures, Fields and Commutators.

ILLINOIS ELECTRICAL MFG. CO.

1222 S. Adams St. : : Peoria, Illinois

## IN PLACE OF OIL, USE . . . LUBRIA

(The Water Lubricant)

A heavy oil to be mixed with 20 to 25 times its bulk of cold water for Boring, Turning, Tapping, etc., and Automatic Machine Work.

Ask for Free Trial Lot.

**FOOTE, PIERSON & CO.,**

80-84 Fulton Street, - - NEW YORK

## ...DYNAMO CASTINGS...

Sets of Material or Finished Parts for the

**FRANKLIN MODEL DYNAMO**

Price \$3.50 and up. Will light six 6 c. p. lamps.

Write for illustrated booklet &

**PARSELL & WEED,**  
129-131 West 31st Street, - NEW YORK CITY

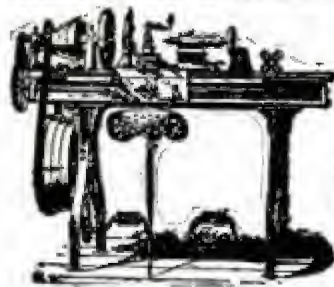

## LATHES

9 to 13 inch Swing

List price, \$65.00 and up according to size. When ready to buy send for Lathe Catalog and prices

**W. F. & John Barnes Co.**  
100 Ruby St., : : Rockford, Ill.

## FOOT and POWER

AND TURRET LATHES, PLANERS SHAPERS AND DRILL PRESSES : : :

**SHEPARD LATHE CO.**

A131 W. 2d St., Cincinnati, Ohio

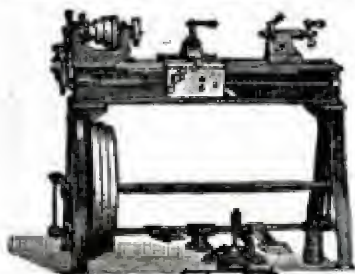

## FOOT and POWER LATHES

9 to 16 inch swing. Built for service.

High Grade, Low Price  
Accurate Tools

CATALOGUE FREE.

**SEBASTIAN LATHE CO.**

107-109 Culvert Street  
CINCINNATI, O.

(Continued from page 163.)

he carelessly hung over the back of his seat a long arm with a fist on the end of it that looked as if it might easily dent the side of a battleship.

"What was that last remark of yours?" he asked.

"I said your smoke was blowing in my face."

The man with the fist took a long pull and blew a few rings into the other's twisted countenance, after which he stood up, saying:

"Then why don't you take your face out of here? They have seats for old ladies in the car back of this."

Owing to the fact that even a man with a disordered liver may be able to take a hint when it is a good plain one, there was no fight. But there was a vacant seat in the smoking car.

## TO MANUFACTURERS.

If you could make another article without further investment in machinery, with no additional overhead expenses, and sell it through your present selling force, wouldn't the profits be "velvet"?

Haven't you some machine that is busy only part of the time and might as well be busy all the time?

Wouldn't another model or something to meet competition make it easier for your salesmen?

If you are selling hatchets, either by talk through the mails, or by word of mouth, couldn't you sell axes and ice-picks at the same time and without additional cost?

Could you utilize that piece of waste material by making something from it?

Are you equipped for press work and buy your castings on the outside, but trying to sell an article made entirely from cast iron, and meet the prices of your competitor whose SPECIALTY is making CASTINGS?

Are you making a good article that doesn't sell as readily as you expected?

If you enjoy a patented monopoly, wouldn't you like to have first choice of all the new things which might destroy your monopoly?

There is something somewhere that would be a help to your business if you only knew what it is and where to get it.

We search the world for new things, or old, applicable to the manufacturing business. New specialties and improvements for old ones.

If there is anything you want to make we will endeavor to find it for you.

If you will send us your catalogue, tell us what line of goods you are especially equipped to make, and your approximate expenditure per year for advertising, we will send you some valuable suggestions.

**POPULAR MECHANICS PATENT BUREAU,**

FREDERICK BENJAMIN, Mgr.,

Journal Building,

Chicago, Ill.

## FARMER'S PHONES IN IOWA.

The mileage of telephone lines in Iowa increased from 14,043 miles in 1903 to 48,491 miles in 1904. In 1903 the mileage of telephone and telegraph lines in Iowa was valued at \$7,797,487, and in 1904 at \$8,808,126. The principal increase was in the rural lines, which explains the disproportionate increase in valuation.

The total production of gold in the United States in 1903 was \$73,591,700 and of silver \$29,322,000. Australia leads in gold production with \$89,210,100.



FOOT AND HAND POWER

# Wood Working Machinery

For Carpenters, Cabinet Makers, Wagon Builders and Wood Workers Generally.

Machines for Scroll Sawing, Ripping, Cutting Off, Mitering, Rabbeting, Grooving, Gaining, Dadoing, Beading, Edging Up, Boring, Mortising, Tenoning, Turning, Etc., for Working Wood in any manner

ENTERPRISING MECHANICS ARE QUICK TO SEE  
THE SUPERIOR MERIT OF OUR MACHINES ::::

Machines Sent on Trial. Send for Catalogue "A."

The Seneca Falls Mfg. Co. 102 Water St.  
Seneca Falls, N. Y.



# CRANE VALVES

ESTABLISHED 1855

## MANUFACTURERS

Why not locate where intelligent labor, raw material and demand

for your product obtains. All these and more found on the BURLINGTON ROUTE. For information write to

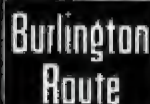

W. H. MANSS, Industrial Commissioner

209 Adams Street - - - - - Chicago

### ELECTRIC FUSE REPLACER.

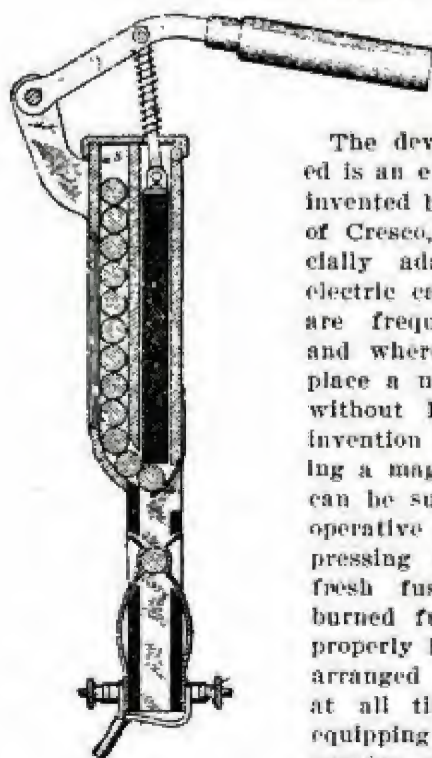

The device above illustrated is an electric fuse replacer invented by Mr. H. G. Addle, of Cresco, Iowa. It is especially adapted for use on electric cars where the fuses are frequently burned out, and where it is desirable to place a new fuse in position without loss of time. The invention consists in providing a magazine of fuses which can be successively placed in operative position by merely pressing down a lever, the fresh fuse forcing out the burned fuse. The parts are properly insulated and are so arranged as to be accessible at all times. The cost of equipping cars or other apparatus with this fuse replacer is nominal.



### DRILLS and Lathes

for everybody. Many styles and sizes, all described in catalog P. Ask for it. B. F. Barnes Company - Rockford, Ill.

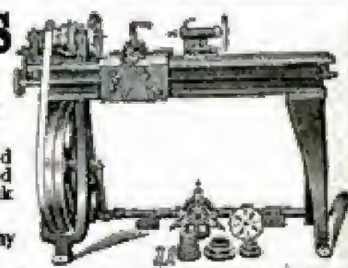

## \$2.70 Tool Set

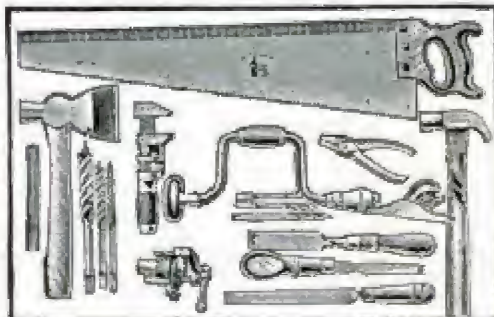

18 warranted tools of best quality—just the set to keep around the farm or house. The above cut shows our 18-piece Star set at \$2.70, complete; 28-piece set, \$7.30; 36-piece set, \$9.70; 41-piece set, \$10.70; 50-piece set, \$16.75, and up to our Carpenters' 95-piece set at \$49.25. If you want Tools of any kind write us for our wholesale price list. We have the largest stock of hardware in the world for sale direct to the user. Tools for every trade, engineers' supplies, building material and building hardware. Write at once for our 624-page Mechanics' Catalogue—a book quoting lowest wholesale prices on standard, guaranteed goods. Catalogue free to any address.

Montgomery Ward & Co. 15  
Michigan Ave., Madison and Washington Sts., Chicago.

**"Wire and Wireless Telegraphy"**  
A book containing good practical information. No big words. Many fine illustrations. Cloth cover, \$1.00; paper cover, 50c. E. B. MOORE, Publisher. Springfield, Vermont



# A Roth Motor will Drive Any Kind of a Machine Tool

No shafting, pulleys or belting to maintain. The motor running any machine not in use can be shut off.

Considering Economy, Efficiency and Design, the **ROTH MOTOR** is beyond reach of competitors.

Self-oiling, noiseless in operation, free from sparking and automatic in its speed regulation at variable loads.

Write us of your motor wants and we will send illustrated catalogue free.

**ROTH BROS. & CO., Manufacturers,**  
27-31 So. Clinton Street, CHICAGO

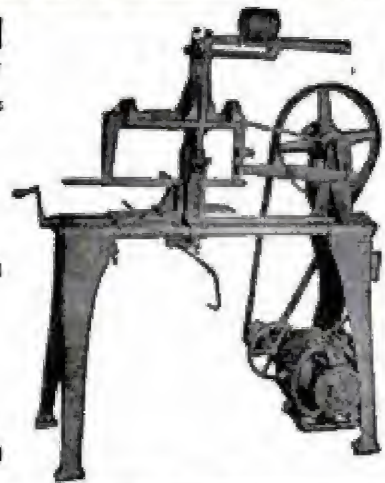

A Roth Motor Drives this Hackaw.

# CRANE FITTINGS

ESTABLISHED 1855

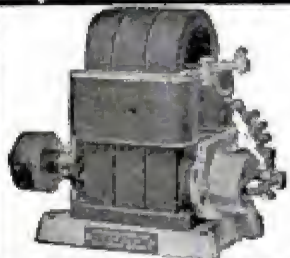

**"Quick Action"**  
IGNITING DYNAMOS and  
MAGNETOS  
The most Reliable Sparkers on the Market.  
Take the Place of Batteries.



**Jump Spark Coils**  
FOR ALL PURPOSES  
Single, Double, Triple and Quad-  
ruple for Stationary Engines and  
Automobiles. Guaranteed in every  
particular. Fine Vibrator.  
SEND FOR CATALOGUE D.  
THE KNOBLOCK WEIDEMAN MFG. COMPANY  
SOUTH BEND, IND.

If you want anything and don't know where to get it write us.  
If you have a new idea or invention ask our Patent Bureau what you want to know and they will answer promptly and fully without charge.  
We want a mechanic in every shop to act as our agent. Write for particulars.  
**POPULAR MECHANICS CO.**

## FIRST PIPE SMOKED IN ENGLAND.



The first pipe ever smoked in England was the one brought back from America by Sir Walter Raleigh, who introduced the smoking of tobacco to white men. The interesting relic is now owned by the Prince of Wales. This is the pipe constantly smoked by Raleigh while writing his "History of the World."

## WOULD MAKE VESSELS BARNACLE-PROOF.

The slimy coating on the scales of fish has been the object of investigation by a Chicago man for some time past. The man believes this coating to be the secret of the fish's agility and sustained life in the water, and has at last produced a composition which he claims is identical with that on the scales and which, if applied to the bottoms of vessels will render them impervious to barnacles. The composition is also said to be moisture-proof and a preservative. If what is claimed for the composition be true, the speed of ships would be greatly increased by its use.

The other fellow's experience may be your teacher. Shop Notes gives many handy little kinks the other fellows have tried and found helpful. Paper covers, 50 cents.

## DUCKS FLY FAST.

We always did suspect that a wild duck could fly faster than a gun can carry, and the speed of a grouse when he rises unexpectedly is phenomenal, but the following instance taken from the Manchester, N. H., Union, certainly establishes a record.

"While gunners are scouring the woods in search of game, the employees of Kendall, Hadley & Co.'s sash and blind factory at Goffstown remain at work and the game comes to them.

"The latest instance of this kind is that of a plump partridge, which flew in at the south door of the factory, smashing the glass in the engine room door, and flew between the spokes of the rapidly revolving fly wheel of the engine.

"Having performed these remarkable stunts, the bird alighted on the top of a cupboard, where it was captured."

To cap the story of the partridge and fly wheel, a correspondent sends the following to the Engineer: Recently a sparrow flew into the engine room of the Bates Machine Co. at Joliet, Ill., and went between the spokes of the two revolving flywheels of the engine—and is flying yet. The two hand-wheels are about 18 and 20 feet in diameter and are set close together on the same shaft. One drives the shafting of the shop; the other the dynamo for lighting.



**DRAFTPHOBIA.**

An extremely odd man was Timothy Quinn;  
He hated fresh air as a parson hates sin.  
He managed to live, notwithstanding his fears  
Of colds, drafts and dampness for thirty-three  
years.

He always insisted, and thought he was right,  
Upon having each door and window shut tight.  
He took so much care of his health that he died  
From a cold which he caught in an open-car ride.  
His folks had him cremated and waited their turn  
To take home his ashes to place in an urn.  
As the oven was opened, all heard a voice roar  
From within: "There's a draft! Oh, please close  
that door!"

—Town Topics.

**RUBBER NECK LAUNDRY.**

Celluloid, or as they are better known, rubber col-  
lars, are more generally worn than most people sup-  
pose. Now an enterprising laundryman announces  
his place as a "Rubber neck laundry."

**DRIVERLESS ENGINES.**

Germany possesses a miniature but most useful  
railway, to which no parallel is found in this coun-  
try. Its peculiarity is that its trains have no  
drivers. It is used for carrying salt from the salt  
mines at Stassfurt. The trains consist of thirty  
trucks, each carrying half a ton of salt. The engines  
are electric, 24 horsepower each. As it approaches  
a station, of which there are five along the line, the  
train automatically rings a bell and the station  
attendant turns a switch to receive it. He is able  
to stop it at any moment. To start it again he  
stands on the locomotive, switches the current and  
then descends again before the engine has gained  
speed.

**FIRES DUE TO CARELESSNESS WITH ELEC-  
TRICAL APPARATUS.**

The quarterly fire report of the electrical bureau  
of the National Board of Fire Underwriters, giving  
accounts of fires due to electrical causes, shows that  
in most cases the fires have either been due to  
carelessness in handling apparatus or in improper  
installation, and not to inherent fault in the appa-  
ratus itself. For instance, there were three fires  
caused by open fuses blowing and setting fire to  
nearby inflammable material. Open fuses are no  
longer countenanced in good electrical construction,  
and in these instances the fault was due to improper  
installation. Two cases were due to electric press-  
ing irons being left with the current turned on.  
Four others originated from incandescent bulbs be-  
ing left lighted in inflammable material. One pecu-  
liar instance is recorded where a barrel of paint  
was being hoisted to an upper floor of a building  
when the grip broke and the paint was precipitated  
onto a generator which was in operation below.  
The paint was ignited and a considerable fire was  
the result.

**ENGINEERS' SOCIETY ELECTS NEW OFFI-  
CERS.**

At the annual meeting of the Engineers' Society  
of Western New York, held Dec. 6, 1904, the follow-  
ing officers were elected by ballot; George H. Norton,  
president; Horace P. Chamberlain, vice-president;  
Alfred T. Thorn, director; Harry B. Alverson, secre-  
tary; Frank N. Speyer, treasurer; William A.  
Haven, librarian.

**GAS & GASOLINE  
— ENGINES —**

2, 3 and 6 H. P., Vertical

8 H. P. up Horizontal. . .

The workmanship and material in every engine built by us is of the highest type obtainable. Durability and efficiency are therefore the most prominent features of CAPITAL ENGINES.

If you are interested in Gas or Gasoline Engines, our Catalog P will show you why our engines are gaining daily in popularity for all purposes. Write for it today—it's Free.

CAPITAL GAS ENGINE CO., Indianapolis, Ind.

**NOTHING BUT THE  
BEST**

EVER GETS INTO OUR

**GASOLINE ENGINES**

All small wearing parts are of hardened tool steel. On every piece the work is better than seems necessary, but it pays, and we are sure that our customers will appreciate it in years to come. Catalogue of our 2½ H. P. dust proof type for the asking.

McNAUGHTON - BASSETT CO.

CHARLOTTE, MICH.

ASK FOR CATALOG P.

THE "GUS" GAS AND  
GASOLINE  
ENGINES

NONE  
BETTER  
MADE



CATALOG  
UPON  
REQUEST

THE CARLANDERSON CO.  
23-27 N. CLINTON ST. CHICAGO

A Good Powerful Engine for Marine  
Service is the

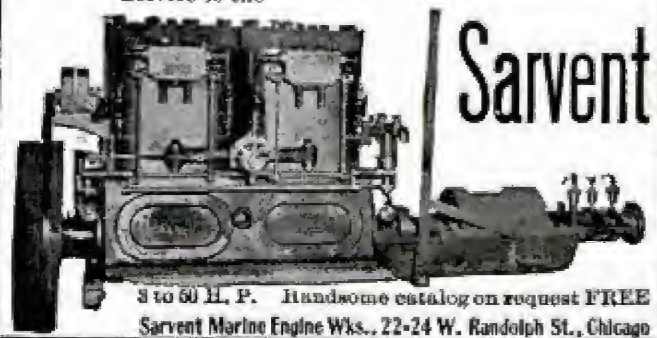

Sarvent

3 to 60 H. P. Handsome catalog on request FREE  
Sarvent Marine Engine Wks., 22-24 W. Randolph St., Chicago



## MARCONI TALKS ABOUT SPACE TELEGRAPHY.

William Marconi has given out the following statement: "We should have our transatlantic service from Glace Bay, Nova Scotia, to Poldhu, England, operating on a commercial basis about the first of this month. At the present time our instruments are installed on 60 ocean-going vessels, but of these only two have the long-distance instruments that operate up to 2,300 and 2,400 miles. The other long-distance sets of instruments will shortly be installed.

"So far we have paid little attention to the land service, although we are operating for the English navy department a service from England to Gibraltar, the messages passing over a greater part of Spain. Something may also be done with land service in Canada for the Dominion government. During the balance of this year our time will be quite fully occupied with improvements in our Glace Bay station, and not until we are perfectly sure of our ability to maintain this service effectively and continuously on a commercial scale will it be thrown open to the public."

## SELF-RELEASING FLOAT FOR FISH LINE.

A well-known English angler gives the following directions for making a self-releasing float for fish lines:

Take a float whose stem extends a half-inch, more or less, above the cork body, all that is necessary is to cut a quarter-inch section off a rubber tube of a size that will fit the stem snugly, then after the line is run through the ring at bottom of stem, simply tuck a loop of it under the tube section. Striking a fish will release the float, or playing the former surely will, whereupon the float slides down the line to the snell or the sinker, and its purpose is accomplished. The facility with which the float may be released can be regulated by using a longer section of tubing and by pushing the folded line further through the latter. By cutting a groove around the top of the stem and taking a turn around this with the line after the latter is pushed through the tube,

a non-resisting device may be had at will, although this would not withstand the strain of landing a large fish without tearing the rubber tubing. Still another method may be employed: Pull the looped line entirely through the rubber tubing and pass over the top of stem, then draw one end until the line passes around the stem but is merely held by the rubber. Tension will release the float.

## NEWEST METHOD OF ROBBING THE MAIL.

It is next to impossible to pilfer a letter from one of Uncle Sam's mail boxes, but some promising young thieves in Minnesota hit upon a plan of doing it which would have succeeded admirably had not an approaching patrolman frightened them away. In their excitement the boys forgot to take their pilfering apparatus, which consisted of a fine large grasshopper let down into the box by a string. The grasshopper would catch hold of a letter with his claws and hang on while the boys drew him through the opening and secured the letter. Then they let him down for another catch.

## AUTOMOBILE AND MARINE MOTORS

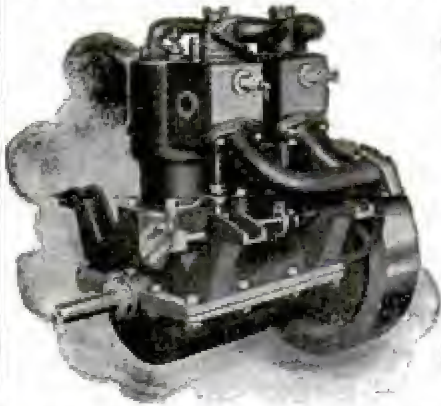

**SIMPLE,  
COMPACT and  
POWERFUL**

Best material.  
Perfect workman-  
ship.  
Send for Catalog.

ALEXANDER & CROUCH,  
71 W. Monroe St.,  
Chicago

1, 2 & 4 Cylinder 4, 8 & 16 H. P.

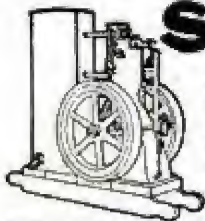

## SIMPLICITY

### GASOLINE ENGINES

Vertical and Horizontal, 1/4 to 15 h. p. Stationaries, Portables, Pumping Outfits and Sawing Rigs.

### GET OUR PROPOSITION

and 1904 catalogue.

Western Malleable & Grey Iron Mfg. Co.  
134 Chase Street, Milwaukee, Wis.

## THERMO-PILES

1 1/2 Volts

1 1/2 Amperes

For Electrolytic Analysis, Charging Storage Batteries, Driving Small Motors, Etc. No chemicals, no smell. **\$3.00 EACH.**

WALSH'S SONS & CO., 261 Washington St., Newark, N.J.

## COOK BROS.

### Reversible Gasoline Marine Motors

LEAD THEM ALL

1 1/2, 3, 5, 6, 10 and 15 H. P. SEND FOR CATALOGUE

PEKIN, ILL., - - U. S. A.

## KEROSENE OIL ENGINE

Stationary, Marine, Portable. Send for catalog  
Int'l Power Vehicle Co., 381 Dearborn St., Chicago



## SPROCKETS

AND EQUALIZING GEARS

IN STOCK OR TO ORDER

Standard makes of Chain on hand.  
Prompt delivery...Catalogue free.

CULLMAN WHEEL CO., 1023 Dunning St., Chicago

## IMPORTED IMITATION

DEDION SPARK PLUGS  
JUST NOW . . . 40 cent each

THE MOTOR CAR SUPPLY CO.

1427 Michigan Ave., Chicago, Ill.



## GAS ENGINES FOR GERMAN WAR SHIPS.

The German navy officials are giving close study to the possibilities of gas engines for propelling war ships. It is reported that the admiralty is having a rather large vessel fitted out therewith for the purpose of making experiments. A discussion on the subject attracted unusual attention at a session of the German Society of Naval Architects.

The chief paper was read by Engineer Capitaine, of Frankfort-on-the-Main, who predicted that gas will displace the present steam engine as well as the turbines. According to the engineer's calculations, the present machine utilizes only twelve to fourteen per cent of the coal's energy, whereas gas engines utilize twenty-six per cent.

The speaker described an invention of his own, which he copiously illustrated by models and magic lantern pictures, whereby he proved that gas can be successfully adapted to driving marine engines. The Thornycrofts, English marine engineers, are now building a vessel to be fitted with a 600 horsepower gas engine.

## CLOCK TO RUN 2,000 YEARS.

A clock which will run for 2,000 years has been invented by Richard Strutt, son of Lord Rayleigh. The motive power is a small piece of gold-leaf which is electrified by means of a very small quantity of radium salt. It bends away from the metal substance and keeps moving under this influence until it touches the side of the containing vessel. At the moment of contact it loses its electrical charge and then springs back and is again electrified, and the process repeated. Sir William Ramsay considers that this may be made into a very reliable time-piece at an expense of about \$1,000.

## DISCOVERY OF PROCESS FOR MAKING HARD RUBBER.

There was once a machinist named George, who worked at the bench and was always more interested in hearing the quitting time whistle blow than in any other event of the day, says Locomotive Engineering. One day the first yell of the whistle found him with his hammer in the air, and being alarmed lest he should make even part of a stroke beyond working hours, he permitted the hammer to fall and it broke a bottle containing a certain chemical which happened to be on his bench and the chemical ran over a sheet of rubber that also was on the bench. To wipe up the mass after the whistle had blown was not the way George did business, so he went home. In the morning when he examined the rubber that had soaked all night in the chemical he found that it was as hard as a piece of board.

Here now came in the worldly wisdom of this machinist. Instead of cleaning up his vice bench, throwing the spoilt rubber and broken chemical bottle into the rubbish box without thinking anything more about the mishap, George reflected that the change in the consistency of the rubber was due to the chemical that had been anointing it all night. Then the question occurred, Would hard rubber have any value as an industrial product? The secret of how to make hard rubber was carefully guarded, a company was formed to put articles made from it upon the market and the discoverer is now a multi-millionaire.

If "Chief Electrician," who omitted the name of his town and state in asking about the magnetizing of a certain steel bar, will send us his full address we shall be glad to give him the desired information. We learn the charge for the work desired is about two dollars.



## MOTOR CYCLES and ENGINES

ALSO CASTING AND FRAME PARTS.

W. HOFFMAN MOTOR WORKS  
1251 N. Halsted St. Chicago



1 3/4 H. P. Bike Motor, \$7.50

CASTINGS WITH DRAWINGS, Latest Model

We also have them in 2 1/2 H. P.

For further information address

Eureka Mfg. & Supply Company,  
St. Paul, Minnesota

## A MOTOR-CYCLE AT SMALL COST



By using one of our Attachable Outlets, THOROUGHLY PRACTICAL. In USE FOUR YEARS. Also a complete line of Motors, Castings and Accessories for Bicycle, Automobile Marine or Stationary.  
Send stamp for Catalogue.

STEFFEY MFG. CO.

Brown and Pnocck Sts., Philadelphia, Pa.

## The New Popular Mechanics PREMIUM LIST

Fully Illustrated  
Is Now Ready

BOOKS FOR MECHANICS,  
ELECTRICIANS, ENGINEERS  
SHOP TOOLS OF ALL KINDS  
SPORTING GOODS, WATCHES, ETC.

Something for everybody given for  
one or more new subscribers.

ADDRESS -

Popular Mechanics  
JOURNAL BUILDING, CHICAGO



## ECLIPSE POCKET AMMETER

For General Battery Testing. 0 to 20 Amperes

Flexible cord attached and contact spur in case, which is DRAWN BACK INTO CASE, when carried in pocket. Size of watch and very light weight. Can be used in any position. Particularly designed for Auto use.

PRICE \$5.00

ELDREDGE ELECTRIC MFG. CO.  
227 Main Street, Springfield, Mass.



# LETTERING

A neat booklet, now ready, contains many good things for students

**PRICE, 25 CENTS**

## DRAFTSMEN, DESIGNERS, ARCHITECTS,

need our new book on dimensions of

### Pipe, Fittings and Valves

NO BOOK LIKE IT

FLEXIBLE CLOTH BACKS, 50 CENTS.

HAVE YOU SEEN A COPY OF

## THE DRAFTSMAN?

It is a neat monthly magazine on DRAFTING and Home Study.

**\$1.00 PER YEAR. 4 MONTHS TRIAL, 25c.**  
or the Magazine and "Lettering" for \$1.00

ADDRESS

**THE DRAFTSMAN, Cleveland, O.**

# POPULAR MECHANICS SHOP NOTES

∴ 128 PAGES ∴  
204 ILLUSTRATIONS

- - -

## Easy Ways <sup>TO</sup> DO Hard Things

- - -

Bound in Cloth - - \$1.00

Paper Covers - - - - .50

SENT POSTPAID ON RECEIPT OF PRICE

## POPULAR MECHANICS

Journal Building

Chicago, Illinois

## AN ENGINEER'S CHRISTMAS WALLET

By Ed. E. Sheasgreen in "Minneapolis Times."

Hank Tullis was just giving the finishing touches to the 391 before leaving time when he was approached by a very well dressed gentleman, all out of breath from hurrying from the H. & N. train to No. 12 of the B. & I. Z.

"What time will you get to The Forks?" asked the gentleman hurriedly.

"About an hour late," answered the engineer, tapping the bowl of his pipe on the drive wheel.

"Why, you will leave here only about that late, and as this train has only three regular stops to make you should get there on time," argued the gentleman.

"Yes, we could, but bad, open, wet weather this fall an' so far this winter has put the track on the slow board an' we're not to make better'n runnin' time. Sorry, sir, but it's orders," slowly spoke Hank.

"Here, read this message! My little three-year-old girl is not expected to live. I've got to get to The Forks on time, so as to make the Chicago connections and be home in the morning—Christmas morning—Christmas morning. This is a case of life and death. I will give you \$100 if you get me there on time," pleaded the desperate man.

"One hundred dollars! Why, man, my job'd go up in smoke; they'd cut my suspenders in a wink—yes, I'd be canned as soon as we got to The Forks. Say, mister, did you say that little kid was three years old? Mine is three years old tonight. She's a Christmas eve girl, an' has got blue eyes an' gold curls, too," said Hank, reading the message.

"So has mine, and she, too, was born three years ago tonight—and, engineer, I love her. Say that you will make The Forks on time and the hundred is yours."

"An' you bet I love my little kid, mister," said Hank, "an' in a case like this I'd make The Forks on time if I lost forty jobs."

Dell True, the conductor, came over with a clearance card and orders to meet No. 91, the local, at Emby and an extra at Hadley. After reading them to his engineer he said, "Remember, old man, not one minute better than running time today."

"Say, Dell, if I get to goin' too fast, don't you pull the air on me. I'm goin' in on time! This man's little three-year-old girl is dyin' an' I'm goin' to get him to her as fast as Nancy can turn 'em; so don't stop me—it's my job an' not yours that'll be lost."

Dell tried to remonstrate, but no, Hank had his mind made up—and when that particular engineer made up his mind that he would play, he would play if it cost his life. Dell knew it. All who were acquainted with Hank knew it.

They left just one hour late, and from the start Dell and the anxious passenger knew their engineer had meant what he said. The schedule of No. 12 was twenty-five miles an hour, but they were soon touching a forty-mile gait—Hank taking advantage of every stretch of good track.

The coaches plunged and rocked frightfully. Everybody was tossed about in a reckless manner. On the engine Bud Wells went through all the movements of an acrobat in trying to guide each scoop of coal to the fire-box door. Hank held to the throttle with one hand and to the arm rest with the other and raised himself from the seat with every wild plunge of the 391. She would raise to the right, then to the left, and throw herself, with all her heavy weight, to the track again, while mud and water, squeezed from the ties and roadbed, shot up and over machinery and coaches until, before they had traveled ten miles, they were coated heavily from truck to roof. They passed a section crew

(Continued on page 172.)



# 25c. BOOKS

on Electricity, Mechanics and other subjects. Send for price list **FREE**.

## HOW TO RUN ENGINES AND BOILERS

by E. P. Watson.

Written in plain language and fully illustrated. \$1.00 postpaid.

7,000 COPIES SOLD

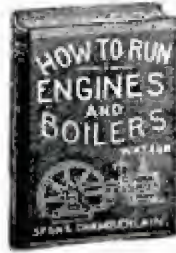

**SCHNEIDER.**—Care and Handling of Electric Plants, \$1.00

**DAHLSTROM.**—Fireman's Guide to the Care of Boilers - - - - .50

**NORRIE.**—Induction Coils and Coil Making for All Purposes - - - - \$1.00

**CROMWELL.**—Easy Lettering for Draftsmen - - .50

**JUST OUT.**—The most complete set of Wiring diagrams and circuits yet published. Limp Cloth, 50c.

*How to Tell the Time* in any part of the world at a glance, a colored movable model, price 25 cents.

**SPON & CHAMBERLAIN**

PUBLISHERS OF TECHNICAL BOOKS

Dept. PM, Liberty Bldg., New York

# Novelties Made to Order

## Metal Stamping

We make Dies and Tools that will turn work out cheaply. Write us—

we'll show you how to place your invention on the market and make money.

**CHICAGO RIFLE MANUFACTURING CO.,**

**11-21 SO. JEFFERSON ST., CHICAGO**

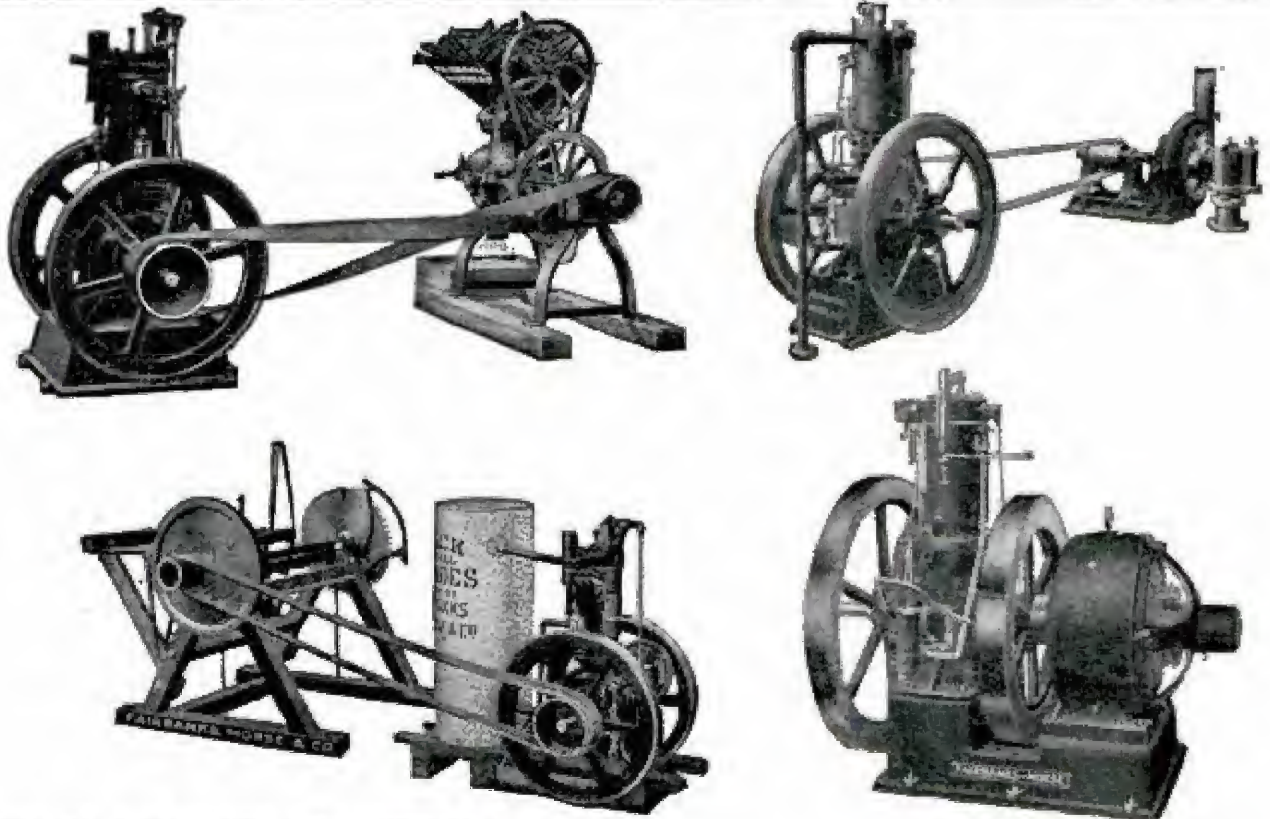

**LOUISIANA PURCHASE EXPOSITION** awarded the

**Grand Prize** to Eclipse Windmills.

**Grand Prize** to Fairbanks-Morse Portable Gasoline Engine.

**Gold Medal** to Fairbanks-Morse Vertical Gasoline Engine.

**Gold Medal** to Fairbanks-Morse Horizontal Gasoline Engine.

**Gold Medal** to Fairbanks-Morse Marine Gasoline Engine.

DEPT. 449-A

**Fairbanks-Morse Co., Monroe St., Chicago, Ill.**

Gentlemen: Please send illustrated catalogue and prices; I may possibly be in the market for the items checked.

\_\_\_\_\_ **Eclipse Windmill** \_\_\_\_\_ gal. Tank \_\_\_\_\_ ft. Tower  
 \_\_\_\_\_ **Fairbanks-Morse Gasoline Engine** and  
 \_\_\_\_\_ **Fairbanks-Morse Gasoline Engine and Dynamo.**

Yours truly,

Name \_\_\_\_\_

Town \_\_\_\_\_

State \_\_\_\_\_



(Continued from page 170).

**SPANGENBERG'S  
PRACTICAL  
ARITHMETIC  
Self-Taught**

# ARITHMETIC

## SELF TAUGHT

Do not despair because through neglect you have forgotten what you once learned about arithmetic. Prof. Spangenberg's New Method requires no teacher.

*228 pages. Will be sent prepaid on receipt of 55 cents in stamps. Best book ever published.*

**GEO. A. ZELLER, Pub.,**  
Established 1870  
23 4th Street, St. Louis, Mo.  
Wanted—Agents Everywhere.

# TELEGRAPHY

**Telegraphers' Penmanship and Typewriting  
COMBINED IN ONE TUITION**

We are unable to meet the demands of the railroads for our graduates. Positions guaranteed to all our students. Send for catalog.

**The Chicago Railway & Commercial Institute**  
97 Washington St., Chicago, Ill.

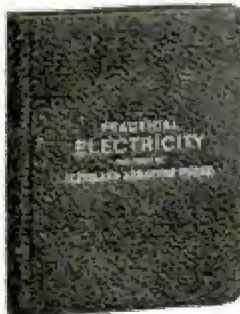

## A School Within Itself

Space will not permit our telling you all about this book, but better still, we give you a chance to examine it for yourself by our offer to refund money if book is not satisfactory upon examination. Under this offer 11,000 copies have been sold and paid for, and out of this number we have refunded for only 20 copies. There are nineteen chapters, carrying you from the fundamental principles of electricity through the art to the finished dynamo and chapter devoted to the electric automobile and batteries. Contains a dictionary defining 1,500 words.

4th Edition. Price, \$2.00 delivered.

**CLEVELAND ARMATURE WORKS: Cleveland, Ohio**

# Telegraphy

taught thoroughly. Institution established 1874

Endorsed by officials Railroads and W. U. Tel. Co. Positions secured. Entire cost, tuition (telegraphy and typewriting, board and room, 6 Mos. course, \$89. Can be reduced. Home instruction also given. Catalogue W free.

**Dodge's Institute of Telegraphy, . . . Valparaiso, Ind.**



## YOU MAY

become a practical engineer by studying the

### YOUNG ENGINEER'S GUIDE

Revised and enlarged to 254 pages. Illustrations. Covers the entire subject of care, management, operation, repairing, engineer's license, etc. Price mailed, leather, \$1.25; cloth \$1. Endorsed by leading engineers everywhere.

**J. V. ROHAN, - Box 20. RACINE, WIS.**

**DRAWING STUDENTS NEED  
THE DRAFTSMAN**

25c for 4 months—Cleveland, Ohio

at Hazel siding. The men ran for the right-of-way fences as they saw the track sinking in front of the wildly coming train. Even to the fences reached the mud and water, while the track behind the train looked like a snake.

At Emby, the first telegraph station, the local crew did the same as the section men. They ran for the fences and the operator swore ever afterward that the whole right side of the engine and train was off the rail and in the air when it passed the depot.

At Classen the order board was out. Hank was hot all over the moment he saw it and before the train came to a dead stop he was chasing Dell into the office. The agent handed this message to Dell: "Is Engineer Tullits crazy? Answer at once. A. B." Hank wrote the answer: "No, I'm not crazy, Tullits." "Say, operator, got any more orders for us?" shouted Hank.

"No, only your message. 'A. B.' is hostile to think you are bustin' his slow orders," answered the operator. At the last word the engineer grabbed the clearance card and ran for the engine. Dell heard him call, "Come on, cap, I'm goin'."

Now, to buck a dispatcher and disregard his slow orders, to grab clearances without knowing positively that there were no more orders, to leave town without the proper signal from the conductor, and to run at such reckless speed over such bad track was more than Dell could stand. But the train was moving and he had just time to catch the last open vestibule. When Hank saw his "Cap'n" safely on he yanked the throttle open and with a mighty bound the 391 responded. Dell would have pulled the air, but he remembered that it was Hank's job and not his. Trusting that the dispatcher would not turn any train loose until Tullits had been caught for sure, he sat down in one of the seats and rubbed his face with his hands.

Twenty miles more and Hadley came in sight. Here they met the extra, just pulling in on the siding, and were to take coal and water. Again the order board confronted them. Dell, white with rage, brought this message to Hank: "Condr True and Engr. Tullits. Why do you persist in disregarding my slow orders? Call at my office on your arrival. A. B."

Hank coolly pencilled this underneath "A. B.'s" message: "Will bust all rules and slow orders. Case of life and death. Don't bother any more. Tullits," and followed to the depot to find out more about orders, where he again grabbed the clearance card, ran to his engine and was under way. He was looking more determined than ever as he said to Wells: "Might as well be ditched for a mogul as a peanut roaster. I'm fired any way, but if nothing happens, even if I have to bust the whole time card an' the constitution of the United States, I'll get that man to his Chicago train on time. Yes, I'm fired all right." He lighted his pipe as a sort of consolation.

Thirty miles more of rocking and plunging and baptism of mud and water with no let up. At Ecken Hank expected to again be stopped and questioned by the dispatcher, but the board was "in" and with a bang they rushed by the depot, over the crossings and on to the last twenty-five miles of the run. The dispatcher had evidently thought Hank crazy, but on getting his message from Hadley decided to give him clear sailing, which was taken advantage of. Ecken was the last telegraph office on the branch, and now Hank more than turned things loose. In almost as many minutes as there were miles did he make The Forks, dropping down Salmots hill like a demon. With a long pull at the chime whistle, he let every one know that No. 12 was coming and would be there on time.

At the depot were the superintendent, the master mechanic and the chief dispatcher—all there to discharge the engineer. Nancy stopped in the train



shed with her nose to the bunting post. In an instant the officials were in the cab and Hank heard from their own lips that he was discharged—fired—canned!

"Couldn't help it; 'twas a case of life an' death," he said, as he got down on the left side of his engine and nervously felt all the bearings. As he stepped to the right side he met face to face the man for whose sake he had lost his job.

"Say, mister, I-I-I'm fired! I got you here on time. There's your train, an' I hope you'll find that kid of yours alive—but I-I-I'm fired though," he stammered.

The officials saw this stranger hand Hank a purse and with it a small white card, and heard him say, "If they won't put you back to work when you show them this card, let me know. God bless you, Tullits, and may you have a merry Christmas," and with a hearty hand shake he ran across the platform and boarded the Chicago train.

Hank looked at the purse and then at the card

## Lowest Prices

for musical goods of the right quality. We sell only the very best grades, the only kind you can afford to buy if you expect satisfactory results.



**\$1.95** up to \$50.00 is our range of prices on violins, 27 different styles to select from. Each instrument absolutely dependable, and offered to you at our wonderfully low wholesale prices.

**\$2.50** buys the genuine Rockwell guitar, 12 other makes at prices lower than can be found anywhere else for instruments of the same quality.

**\$2.95** is our wholesale price to you for a genuine Glenwood mandolin, an instrument that sells for \$4.00 to \$6.00 elsewhere.

We handle everything in musical goods and will gladly send our interesting catalogue to any person who can possibly use a musical instrument of

any kind. Ask for Musical Instrument Catalogue.

**Montgomery Ward & Co.,**  
Michigan Ave., Madison and Washington Sts., Chicago.

in a dreamy sort of way and muttered: "One hundred dollars an' a white card for my job! Guess I was an easy mark sure enough. Poor starter for next year's Christmas." He turned the card over, then right side up, and read:

A. N. CAZZLER,

Chicago,

Director  
H. & N. and B. & I. Z. Rys.

Illinois.

The next day after Christmas, when Hank was getting ready to leave The Forks with No 11, the office boy handed him a letter from Mr. Cazzler, saying in part:

"Baby alive and improving. Here is a small shin plaster for the sore spots on your body from that fierce ride of yours day before yesterday," and the rough old engineer had just time to wipe away a tear and hide the new hundred dollar check in his wallet, when Dell called out, "Bo-o-o-ard!"

# Engineering

MECHANICAL,  
ELECTRICAL,  
STEAM,  
CIVIL.

Complete and short courses. Thoroughly equipped engineering shops. Shop work from the beginning. Short courses in Steam and Electrical Engineering. Expenses low. Accommodations the best. School all year. Students may enter any time. Correspondence steam and electrical courses. Send for catalogue. Mention course in which interested.  
**HIGHLAND PARK COLLEGE, Des Moines, Ia.**



## Air Brush for Art Work

WE ARE MAKING THE STANDARD.

The best in use for applying color by a jet of air. Enables you to do better work in less time. Found in every complete studio. Circular free.

WRITE TO-DAY

**Air Brush Mfg. Co.,**

127 NASSAUST.

ROCKFORD, ILL. U. S. A.



## A GOOD Drawing Table

CASH WITH  
ORDER. PRICE, \$5.00

Adjustable to height and angle. Top of hard or soft wood 20 x 28 inches. Shipped in the knock-down by freight. Weight 50 lbs. Circulars free of full line of Tables.

The Hetterschied Mfg. Wks.

317 S. Division St.  
GRAND RAPIDS, MICH.

Columbia No. 1

## NOTICE

TO LOCAL SUBSCRIPTION REPRESENTATIVES OF

**POPULAR MECHANICS** ££

You are expected to keep track of your subscribers and secure their renewal and forward same to the home office not later than the first of the month in which the subscription expires. Failing to do this we will then notify the subscriber direct from this office, but will recommend he hand the renewal to you to be forwarded ££ ££

**Popular Mechanics**



# Patents, Metal Specialties, Novelties, Tin and Aluminum Boxes

We make them all and anything in the metal line---Punches and Dies---Special Tools and Machinery---Boxes of special design and patterns; also experimental work at reasonable rates. All work guaranteed.

**GREENLEAF & BACON, : : 42 and 44 Michigan Street : : Chicago, Ill.**

## BUBIER'S POPULAR ELECTRICIAN

**3 mos. 10 cts.**

THE ONLY AMATEUR ELECTRICAL PAPER IN U. S. SCIENTIFIC BUT NOT TECHNICAL. EDITED BY EXPERT ELECTRICIANS. DEPT. 3 LYNN, MASS. 3 YEARS, \$1

**WM. ZIMMERMAN PATENT-LAW, PATENTS, TRADE MARKS, LABELS ETC. 1000 TRIBUNE BUILDING TELS., CENTRAL-4985 and AUTOMATIC-3984**

# PATENTS

Valuable Book on Patents FREE. Tells how to secure them at low cost. How to sell a Patent and What to Invent for Profit. Gives Mechanical Movements invaluable to Inventors. Full of Money-Making Patent Information. NEW BOOK FREE to all who write.

O'MEARA & BROCK, Patent Attys. 918 F. Street, Washington, D. C. NEW YORK OFFICE. 288 Broadway, New York City

**PATENT** Secured or No Fee Guide Book Free  
Tells more about Patents than any book published  
Wilson & Co., 865 F St. N. W., Washington, D. C.

# MODELS AND SUPPLIES

Send for Illustrated Catalog of Appliances for Models  
**J. WEINERT & CO., 134 Pierce Avenue, Chicago**

NAME PLATES, TRADE MARKS



TRANSFER WINDOW SIGNS

# MODELS CHICAGO MODEL WORKS

175-181 E. MADISON ST., CHICAGO, ILL.

ESTABLISHED 1867

WRITE FOR CATALOGUE OF MODEL SUPPLIES

# WE MANUFACTURE

Metal Specialties, Dies, Tools, Metal Stampings of all kinds, Screw Machine Work, Novelties, etc. Estimates cheerfully given. Send drawing or models.

**Metal Specialty Mfg. Co., 18-24 W. Randolph St., Chicago**

### THE THINNEST WATCH MADE.

What is claimed to be the thinnest watch made in the world is manufactured in England and sells for \$5 up to \$25. They are claimed to be perfect



**Actual Size of Thinnest Watch Made**

timekeepers, notwithstanding the extremely delicate construction of the works necessary to be contained in so thin a case. The actual thickness of the watch and case is only three-sixteenths of an inch.

One of our readers asked where he could secure the book on artificial rubber, "Cellulose," by Dr. Borsch. It can be had of Messrs. Henry Carey, Baird & Co., 810 Walnut street, Philadelphia, Pa.

The Alaska season for 1904 is closed and her gold production is estimated as follows: Klondyke, \$11,000,000; Nome, \$10,000,000; Tanana, \$2,000,000; all other districts \$3,000,000. Total, \$26,000,000.

CATALOGUE FREE TO ANY ADDRESS

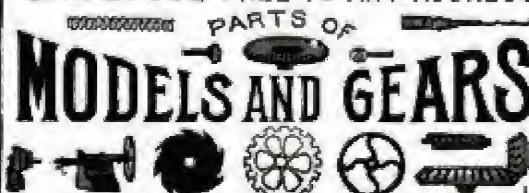

GEAR CUTTING  
EXPERIMENTAL WORK



# WE MANUFACTURE STAPLE GOODS AND SPECIALTIES IN CAST BRASS AND SHEET METAL

Estimates Furnished from Models or Blue Prints

Correspondence Solicited

FROST MANUFACTURING COMPANY

37-53 SOUTH PLEASANT ST. : : : : KENOSHA, WIS.

## PATENTS Valuable and Salable Patents Secured. Advice as to Patentability and Commercial Value Free

**SHEPHERD & PARKER, PATENT LAWYERS**

"During the past 10 years Mr. Shepherd, of Shepherd & Parker, has obtained for us a great many important patents. We have no hesitation in heartily recommending him to anyone having need of the services of a patent attorney.

HALLWOOD CASH REGISTER CO.

Mr. Parker on Nov. 1, 1903, resigned his position as an examiner in the U. S. Patent Office to enter this firm. Address

210 Revenue Building . . . WASHINGTON, D. C.

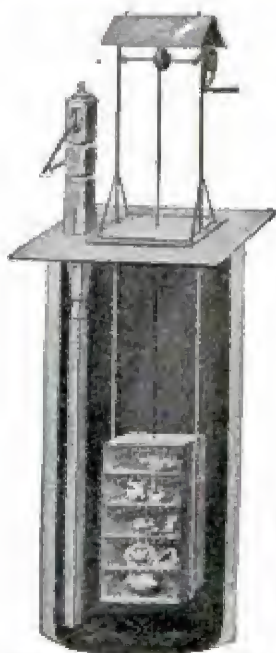

Combined Well and Refrigerator

### WELL INSTEAD OF ICE FOR REFRIGERATOR.

It may be a little out of season just now to tell how things may be cooled, but anyway it won't hurt to recall the hot days that were and get ready for more later on. The latest substitute for ice in places where it is not easily obtained, or is quite expensive, is to lower the "refrigerator" into a well. The box contains several shelves, reached by swinging doors, and is lowered and raised by means of a windlass. The cage or box is kept in position by two guide rods, and the cover in the well is lifted when the ice-box comes up, and returns to position when it is again lowered. The pump takes a sidestep when the refrigerator is installed.

## CARPETS ON TRIAL



rugs with fancy border and fringe to cover big parlors. \$1.92 and up. We will explain why we can sell CARPETS AT ABOUT ONE-HALF THE PRICE OTHERS CHARGE.

OUR FREE TRIAL PLAN will be fully explained. How we cut and make carpet in any shape to fit any room, our binding quality guarantee, our pay after received terms, quick delivery, color scheme, very little freight charges, all will be explained to you. Cut this ad out and send to us or on a postal card say, "Send me your Free Carpet Catalogue," and you will get all this free, and you will get our very latest and most astonishingly liberal carpet offer, a carpet proposition never known of before. WRITE TODAY and see what you get FREE by return mail, postpaid. Address, SEARS & ROEBUCK & CO., Chicago.

### SPECIAL MANUFACTURING

## Dies and Stamping

-- TO ORDER --

SPECIAL MACHINERY, MODELS  
EXPERIMENTAL WORK

DROP FORGING DIES AND DROP FORGINGS

Hardware Specialties, etc., Man'd to Order. Send Samples or Drawings for Estimates. Write for Our Booklet.

THE GLOBE MACHINE & STAMPING CO.  
973 Hamilton St., - Cleveland, Ohio

Send three one-cent stamps for 5-color  
PICTURE OF LINCOLN PARK BRIDGE

W. L. STEBBINGS

Civil and Consulting Engineer  
LICENSED ARCHITECT

Monadnock Block, - - - Chicago

Tel. Harrison 1104 Cable Address "Stebbing" Directory Code

+ ADD TO +  
YOUR SUCCESS

ALL METAL  
MODEL  
\$5.00

Save time now wasted in adding  
long columns by using

THE LOCKE ADDER.

It minimizes time, expense and drudgery of business details. Adds, subtracts, multiplies and divides. Capacity, 999,999,999. Cannot make a mistake. One of the fastest adding machines made. No complicated mechanism to get out of order; no expert repair man's bills to pay; no breaks to cause delay and inconvenience. Ready to use any time, any place. Simple, light, handy. Size, 4x10 1/2 inches. All metal. Price, \$5.00, prepaid in U.S. Send for FREE descriptive booklet. Agents wanted.

Buy

a Locke

Adder to Save

C. E. LOCKE MFG. CO.

98 Walnut Street, Keosauqua, Iowa.



## ELECTRIC RAILWAYS

Dynamos : Motors : Gas Engines



Complete Working Models, also Castings and Parts. Everything for the Amateur Electrician. Send for Catalogue B

**The CARLISLE & FINCH CO.,**  
262 E. Clifton Ave. Cincinnati, Ohio



A light when you want it. No chemicals, oil, smoke or odor. Indorsed by Army and Navy, and all Detective Dep't's. Send us \$1.00 and we will ship flashlight complete immediately prepaid. Other Specials: Electric Motors, \$1.50 and 15c postage. Electric Top, 75c and 15c postage. Shocking Machine, \$1.00 and 30c postage. Write for our book No. 6 of Electrical Goods. IT'S FREE. J. ANDRAE & SONS CO., 493 W. Water St., Milwaukee, Wis.

### The World's Headquarters for ELECTRIC NOVELTIES and SUPPLIES

If It's Electric We Have It.—We Undersell All



Xmas Tree Lamps & Battery	\$3.00
Fan Motors, \$2.00 to	\$15.00
Battery Table Lamp	3.00
Battery Hanging Lamp	10.00
Telephone, complete, \$2.50 to	5.95
Electric Door Bells,	1.00
Electric Carriage Lamps,	5.00
\$3.00 Medical Batteries,	3.95
\$13 Belt, with Suspensary,	2.50
Telegraph Outfits,	2.00
Battery Motors, \$1.00 to	12.00
Bicycle Electric Lights,	3.50
Electric Railway,	3.25
Pocket Flash Lights,	1.25
Necktie Lights,	1.00

SEND FOR NEW CAT., JUST OUT

\$3 Electric Hand Lantern. Agents Wanted—  
**OHIO ELECTRIC WORKS, .: Cleveland, Ohio**

### SPECIAL DOLLAR ELECTRIC BARGAINS

Electric Pocket Light . . . . .	\$1	We keep all Electric
" Scarf Pin . . . . .		Novelties.
" Motor . . . . .		Send for catalogue.
" Bell Outfit . . . . .		Electric Novelty Co.
" Top . . . . .		16 E. Market St.
" Shocker . . . . .		INDIANAPOLIS
" Induction Coil . . . . .		IND.



### Every Boy His Own Toy Maker

Tells how to make all kinds of Toys, Steam Engines, Photo Cameras, Windmills, Microscopes, Electric Telegraphs, Telephones, Magic Lanterns, Zolian Harps, Bonts, from a rowboat to a schooner; also Kites, Balloons, Masks, Wagons, Toy Houses, Bow and Arrow, Pop Guns, Slings, Sticks, Fishing Tackle, Rabbit and Bird Traps, and many others. All is made so plain that a boy can easily make them. 200 handsome illustrations. This great book by mail, 10c, 3 for 25c.

Western Specialty Co., 532 E. Minnehaha St., St. Paul, Minn.



### THE RELIABLE ELECTRIC VEST POCKET LIGHT

If you wish to find a house number at night; if you wish to find an article you have dropped; if you wish to avoid dangerous places in dark streets, just "press the button" and you have an instant, brilliant light. Will give eight thousand flashes, or burn three months with right usage. Inexpensive to buy and to operate! Invaluable to physicians, or miners and gasfitters who go in dark places where any other form of light is dangerous. Batteries and bulbs easily detached and renewed when required.

\$1.00—Complete—\$1.00 Postage prepaid. Extra batteries 30c. Extra bulbs 35c

Write for prices in quantities and complete catalog. Agents wanted. HOWARD ELECTRICAL NOVELTY CO., 188 Lake St., Chicago.

Mrs. Elsmere has inherited an unshaken belief in the superiority of wood for cooking purposes and has had frequent recourse to a row of tumble down houses some three blocks from her fashionable South Side residence to secure the services of colored wood choppers. On her last trip she failed to find any men available, says the American Artisan. She was, however, eagerly and quite grammatically accosted by a fourteen-year-old colored boy as follows: "Were you looking for some one to chop your wood, Mrs. Elsmere?"

He was promptly engaged for the afternoon and from 1 p. m. to 6 p. m. the sound of an axe could be heard in the Elsmere barn.

When the youthful laborer appeared for his pay, the lady feeling in a liberal mood offered him 50 cents, considering that handsome wages for a lad of his age.

"Beg pardon, Mrs. Elsmere, but my charges are 25 cents an hour, making \$1.25."

"One dollar and twenty-five cents? What are you talking about, child? Why, your father and the other men in your block only charge 15 cents an hour."

"I know that, and if I didn't work any harder than they do, I wouldn't have the nerve to charge even 15 cents. I want you to see how much I chopped. If I haven't done over twice as much in an afternoon as my father ever did, you needn't pay me anything. If I have chopped over twice as much as the men do, ain't I really cheaper at 25 cents than they are at 15 cents?"

The pile "made good" and so did Mrs. Elsmere.

### A FABLE.

Once there was a Man who had a valuable Wife. She was Kind and Gentle and would stand without Hitching. She was trained to not Sit up for Him and she had no Relatives nearer than a Seventh Cousin who lived in New Zealand. Now, this Wife was taken ill and the Man was sore distressed thereat.

In the next Office to this Man was another Man who was a Bachelor, engaged in the manufacturing business, and at his Factory was a Steam Boiler of great Horsepower and consequent Intrinsic Worth. Now, this boiler was after the manner of Boilers out of Kilter one day and the Engineer adjured the man to send for a Machinist to Prescribe for the boiler's Ailments.

Both of these gentlemen at one and the same time seized the telephone and called up, the one a Doctor of Medicine and the other a Doctor of Steam Boilers. The Telephone Girl, after making the connection, by that strange instinct of telephone girls to do the Wrong Thing, changed the wires and the astonished husband received the following advice from the Machinist:

"Pound her on the sides until you loose the Scales and then Flush her out with the garden hose."

The manufacturer in the meantime was equally shocked to hear the oily voice of the lady's physician advise the following for the case of the boiler:

"Administer two grains of Quinine and apply Hot Cloths to the parts affected."

Moral.

When advertising don't get your wires crossed.



# HERE IT IS JUST WHAT YOU WANT \$1.00 POSTPAID A POCKET FLASHLIGHT

Has thousands of flashes for thousands of uses. The handiest light you ever used. Is always ready. A push on the button gives a bright flash, may be used in a cellar full of gas or lighted in keg of powder without danger.

A Dollar Bill Brings it by Return Mail

Pocket Flashlight with special finish and lens. • \$1.25  
 Extra Batteries 30c. Elec. Bicycle Lamp \$3.50  
 Extra Bulb 25c. Elec. Scarf Pin 1.00  
 Cylindric'l Flashlt. \$2.00 Elec. Night Clock 3.00  
 Elec. Range Lighter 1.75 Elec. Candle 3.00  
 Elec. Walking Cane 5.00 Elec. Yacht Search Light 5.00  
 Elec. Carriage L/p. 5.00  
 Night Light and Watch Stand \$3.00

Our Catalogue of Interesting Electrical Novelties FREE

**NORTH SHORE ELECTRIC WORKS, Dept. E, - - Kenilworth, Ill.**



We have a large stock of all kinds of Electrical Goods and can furnish anything from a push button to a lighting plant.

## ELECTRIC MOTOR 75c.

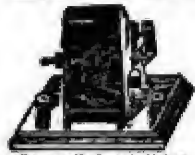

Runs with a wet or dry battery, ask any electrical dealer or look through any electrical catalogue and see if you can buy an electric motor with 2-inch armature, wrought iron field magnet, pulley, etc., for 75 cents, packing and postage, 15 cents.

**CATALOG FREE**

Dry batteries for operating motors, induction coils, small electric lights, and experimenting, 25 cents each, postage and packing, 10 cents. Send 10 cents for 10 feet of magnet wire for experimenting and making small magnets.

**Artesian Electric Co., 744 Artesian Ave., Chicago**

**69 CENTS**  
**POCKET ELECTRIC FLASH LIGHT**

Postage extra, etc. The best made; lasts the longest; gives most powerful light. It's always ready—simply press the button. Extra batteries 25c each. Agents make big money. Send for catalogue. **THE YIK CO., 65 E. Lake St., Chicago.**



## MAGIC

**I will teach you one new coin trick and one new card trick for 20 cts. or either for 10 cts. I will send "Book of Card or Coin Tricks," 180 p., 25c. each, and include illus. catalog of 240 tricks free with order. Learn at home, amaze your friends, mystify, startle and entertain. ROBERT WASSMANN, Instructor in Magic, 227-z Webster Ave., CHICAGO, ILLINOIS.**

**ELECTRIC MOTOR & COUNTER SHAFTING \$2**

The most practical, useful, instructive electrical appliances made. Size, 11 1/2 x 19 7/8 inches. Works perfectly. Outfit complete, ready for use, \$2.00. Send for catalogue No. 6 full of electrical goods. **J. Andrae & Sons Co., 472 West Water St., Milwaukee, Wisconsin.**

## Magic Trick Cards.



With these cards you can perform some of the most wonderful illusions. You can change eights to deuces, blacks to reds, etc. The transformations are truly wonderful. **Price, 10 cents** with instructions, and our Big Bargain Catalogue.

Address

**Western Specialty Co., 532 E. Minnehaha St., St. Paul, Minn.**

## BOOK REVIEWS.

**MECHANICS, MOLECULAR PHYSICS AND HEAT, Twelve Weeks' College Course.** By Robert Andrews Millikan, Assistant Professor of Physics in the University of Chicago. 8vo. Cloth, 242 pages. Illustrated. List price \$1.50; mailing price \$1.60. Ginn & Company, Publishers, Boston.

This book is designed to take the place of a classroom text-book and a laboratory manual. It is built up about a number of well-chosen experiments and teaches a few facts thoroughly rather than presenting a great amount of material. The book is a continuous course, the logical sequence of the chapters being carefully followed out.

**WIRE AND WIRELESS TELEGRAPHY.** By Edmund B. Moore. Cloth \$1.00; paper 50 cents. E. B. Moore, Springfield, Vt. A little book of technical information describing the history of the electric telegraph from its birth to the present time. The apparatus employed in wireless telegraphy is carefully explained and the advantages of its use upon the ocean are discussed. Many illustrations and wiring diagrams making plain the different systems are given also. In all, a very neat and interesting little volume on a thoroughly modern topic.

**ANNUAL REPORT OF THE SMITHSONIAN INSTITUTION.**—The annual report of the board of regents of the Smithsonian Institution, Washington, D. C., contains, in addition to the usual report of the business of the institution, a good number of valuable papers in the general appendix. The following may be mentioned: "Progress of Air Ships," by Major B. Baden-Powell; "Aerial Navigation," O. Chanute; Graham Bell's Tetrahedral Kites; "Radium," by E. Curie; "Radium," J. J. Thomson; "The N-Rays," by M. Blondlot and C. G. Abbott; "Modern Views on Matter," by Sir Oliver Lodge; "The Electric Furnace," by J. Wright; "The Marienfelde-Zozzen High-Speed Electric Railway Trials," by Alfred Gradenwitz.

**ELEMENTS OF DIFFERENTIAL AND INTEGRAL CALCULUS with Applications.** By William Anthony Granville, Instructor in Mathematics in the Sheffield Scientific School, Yale University. 8vo. semi-flexible cloth. Illustrated. List price, \$2.50;

(Continued on page 178.)

**"THE MYSTIC" ELECTRIC VEST POCKET FLASH LIGHT**  
 Sent to any address post paid  
 Send for free catalog.  
**FAY MARTIN CO. 90c**  
 1650 N. Clark Street Chicago Ill. Dept. 3





# ELECTRICITY BOOK FREE

Profusely Illustrated With Photos From  
Life. Write For It To-day.

This splendid book is compiled from the best authorities in the world. Explains how electricity as supplied by inexpensive batteries cures Rheumatism, Dyspepsia, Insomnia, Liver and Kidney Trouble and all nerve affections and diseases due to poor circulation.

Explains how to enjoy the famous electric baths and beauty and health massage at home at little cost.

THIS  
BATTERY

\$ .95

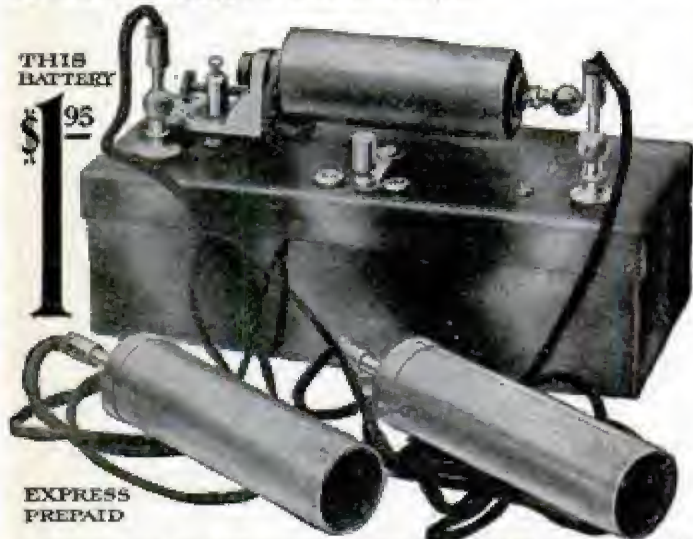

EXPRESS  
PREPAID

This book also lists the latest improved Batteries (Prices, \$1.95 to \$11.35) which we send prepaid, and allow 10 days free trial.

**DETROIT MEDICAL BATTERY CO.,**  
139 Walker Block, Detroit, Mich.  
*Write to-day for our Free Book.*

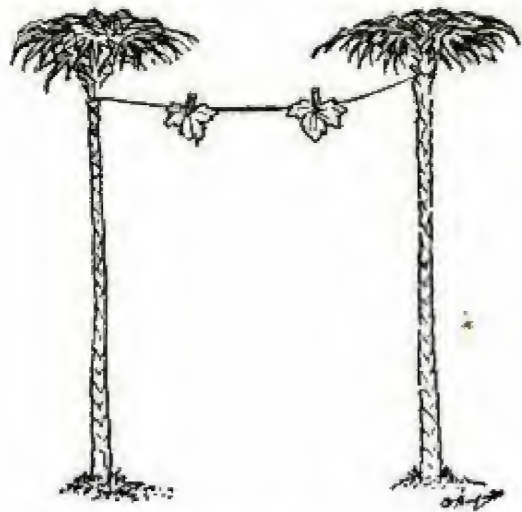

## The First Monday

From "The Entirely New Cynic's Calendar"  
Copyright, Paul Elder and Company, San Francisco

mailing price, \$2.70. Ginn & Co., Boston. This is a standard text-book especially designed for the use of students in colleges and engineering schools. Some of its special features are a collection of elementary formulas from Algebra, Geometry, Trigonometry, and Analytic Geometry, and a large number of examples under each topic by way of illustration. There are about 250 figures which have been prepared at a great expense in such a manner that they are surpassed by no other text book on the Calculus in the English language.

**A MODERN BATTLESHIP.** Encyclopedic X-Ray Engraving, Numbered and Named. Size 28x44 in. Heavy plate paper, 50 cents; edition de luxe, linen on stretcher, \$5.00. The Derry-Collard Company, 256 and 257 Broadway, New York.

This is a highly instructive and most interesting chart. A modern battleship with guns, turrets, ammunition stores, boilers, engines, wireless telegraph, hospital—everything that enters into the big leviathans that cost the Government from \$5,000,000 to \$8,000,000 each, numbered and correspondingly numbered and named below. Not only that, but drawn to a scale so accurately that one obtains a correct estimate of the size of each part in relation to the others and can measure for himself. It is safe to say that that one could learn more about a battleship from this chart in an hour than he could in a careful perusal of a book on the subject.

**THE AMERICAN WELL WORKS,** of Aurora, Ill., have just issued their general manufacturer's catalog, a neat little volume replete with interesting descriptive matter and illustrations in their line, together with up-to-date prices. The book also contains many valuable tables and some useful hydraulic information.

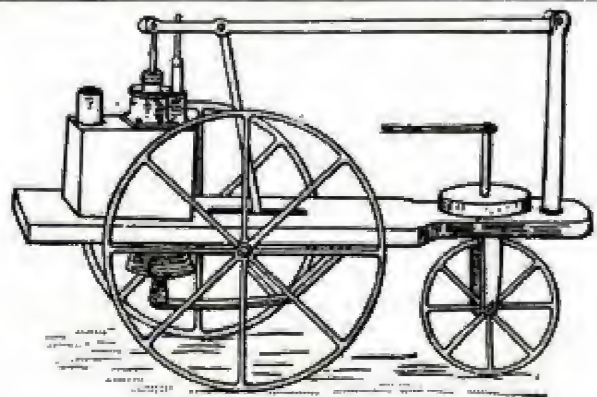

Murdock's Motor Cycle, 1783

## Common Red Clover

Cures Cancer, Eczema, Salt-Rheum, Rheumatism and all other Blood Diseases



How many people realize the true value of our common red clover? It is the best blood purifier known. Thousands of prominent people have been cured of cancer, rheumatism, constipation, eczema, skin and blood diseases by its use. Send your address to D. Needham's Sons, 116c Lakeside Bldg., Chicago, Ill., and they will mail free a full description of Red

Clover Blossom Extract, a history of how Mr. Needham cured his cancer and testimonials from many who have used the remedy. If you have any disorder of the blood look into the merits of Needham's Clover. It is the best blood purifier known.

# RUPTURE

Our 24-page book free describes the greatest invention of the 20th Century, for the relief and cure of Rupture. Shows interesting photos from life and contains new and valuable information. Greatest trial offer ever made by any firm. You will be interested. Write today.

**DENCE & MERY, 160 Mery Block, Toledo, O.**

## WONDERFUL STOVE—BIG MONEY MAKER!

**BURNS 90% AIR—ONLY 10% OIL-GAS.** 7200 sold one month. Customers delighted with Harrison Valveless Oil-gas Stove. Splendid for cooking; also heating rooms, stores, offices, etc., with Radiator Attachment. No wick, dirt, or ashes—no coal bills or drudgery—cheap, safe fuel, 15c to 20c a week should furnish fuel-gas for cooking for small family. Easily operated—absolutely safe—all sizes, \$3 and up. Write—Catalog FREE and Special Prices. AGENTS WANTED—\$40 Weekly. Call in or address

**WORLD MFG. CO., 5790 World Bldg., Cincinnati, O.**



**FREE HAIR FOOD**



**FALLING HAIR AND BALDNESS ABSOLUTELY CURED**

There is but one way to tell the reason of baldness and falling hair, and that is by a microscopic examination of the hair itself. The particular disease with which your scalp is afflicted must be known before it can be intelligently treated. The use of dandruff cures and hair tonics, without knowing the specific cause of your disease, is like taking medicine without knowing what you are trying to cure. Send a few fallen hairs from your combings, to Prof. J. H. Austin, the celebrated Bacteriologist, who will send you absolutely free a diagnosis of your case, a booklet on care of the hair and scalp, and a sample box of the remedy which he will prepare specially for you. Enclose 2c postage and write to-day.

**PROF. J. H. AUSTIN**  
178 McVicker's Theatre Bldg., Chicago.

**A \$1.00 PAIR FREE TO TRY**



If you have

**RHEUMATISM**

Send your name today and get this Remarkable Cure by Return Mail.

To those who answer this advertisement at once will be sent free to try a pair of the Celebrated Magic Foot Drafts, the great Michigan discovery which is curing all kinds of Rheumatism, including even some of the worst chronic cases in the state. These Drafts are worn on the feet (without the least inconvenience), but they cure Rheumatism in every part of the body, by absorbing the poisonous uric acid and other impurities from the blood through the great foot pores. Don't think that because this remedy is simple and cheap it won't cure. **IT WILL**, and already thousands have written us that it **HAS** cured them. It will cure **YOU**. Send us your name today and give the Drafts a trial. If you are satisfied with the benefit received from them, then send us one dollar. If not, keep your money. **YOU DECIDE**. A splendid new booklet on Rheumatism, illustrated with colored plates, comes free with the Drafts. Write today to Magic Foot Draft Co., 151 Oliver Bldg., Jackson, Mich. Send no money, only your name.

**You Can BUILD IT YOURSELF**



We tell you how to do it, show views of machines built at home and many letters from satisfied customers in our new book "How to Make and Save Money with Incubators and Brooders." Full of good things. Invaluable to the beginner. You save half the cost of your incubator. None hate better. Get the Book and know for yourself.

**CHANNON, SNOW & CO., Dept. 198, Quincy, Ill.**

**STEVENS**



You cannot possibly enjoy Shooting—the King of Outdoor Sports—unless properly equipped. There is only one way of being sure to have the right arms. Secure a weapon with a Record. The "STEVENS" will suit your requirements in every particular, and has forty years of experience and achievement back of it.

We manufacture a complete and varied line of:

**Rifles, Pistols, Shotguns**

Ask your dealer and insist on the STEVENS. If you cannot obtain them let us know and we will ship direct, Express prepaid upon receipt of price.

136 page illustrated catalog relative to our products, firearms, accessories, hints on shooting, etc., mailed for 4 cents in stamps to cover postage. Send for clever little rifle puzzle.

**J. STEVENS ARMS & TOOL CO.,**  
40 Main Street  
CHICOPEE FALLS, - Mass., U. S. A.

**Are You a Lover of Good Tea and Coffee**



We are making a Special Proposition to those who enjoy a beverage that is not only delicious, but more appetizing and nutritious than any other tea and coffee on the market.

Write for Special New Year Proposition to persons getting up clubs or sending orders of \$5.00 and upwards.

It is worth your while, as we intend to use unheard-of efforts to increase the number of customers during the next two months. This offer applies only to readers of Popular Mechanics

Write us at once—to-day—to

**MR. CARL,**  
**Great American Tea Co.,**  
31 & 33 Vesey St., P. O. Box 289, New York

**ROYALTY PAID** and Musical Compositions. We arrange and popularize.

ON

**SONG-POEMS** **PIONEER PUB. CO.,**  
627 BALTIMORE BLDG.,  
Chicago, Ill.



**YOU CANNOT "MAKE BRICKS WITHOUT STRAW"  
BUT YOU CAN SECURE ANY OF THESE**

# High Grade Tools Without Money

The following carefully selected list of tools includes those which every mechanic needs, and which everyone who engages in mechanical work as a recreation will greatly desire to possess. We have selected a well-known brand, the excellence of which for quality and accuracy is beyond criticism. They are all from the celebrated works of the L. S. Starrett Company, manufacturers of fine mechanical tools. Every tool in these lists can be easily earned by securing a small club of new yearly subscribers to Popular Mechanics;

## ANY TOOL IN THIS LIST FOR ONE NEW SUBSCRIBER

	Retail Price.
No. 303 4-in. Spring Tempered Rule.....	\$ .45
No. 403 4-in. Beveled Edge Rule.....	.45
No. 330 4-in. Narrow Hook Rule.....	.45
No. 391 Spring Tempered Center Gage.....	.45
No. 450 Folding Pocket Rule in case.....	.50
No. 135 Nickel Plated Pocket Level.....	.50

## ANY TOOL IN THIS LIST FOR TWO NEW SUBSCRIBERS

No. 303 Spring Tempered Rule, 9-in.....	1.00
No. 403 Beveled Edge Rule, 9 in.....	1.00
No. 420 Hook Rule, 6 in.....	1.00
No. 21 Thin Straight Try Square, 2 in.....	1.00
No. 125 Adjustable Caliper Gage, 2½-in.....	1.00
No. 193 Protractor.....	1.00
No. 40 Screw Pitch Gage.....	1.00
No. 172 Thickness Gage.....	1.00
No. 87 Mercury Plumb Bob.....	1.00
No. 146 Adjustable Hack Saw Frame and Blade	1.00
No. 104 Speed Indicator.....	1.00
One Dozen No. 116 Asst. Nail Sets, in case.....	1.15

## ANY TOOL IN THIS LIST FOR THREE NAMES EACH

ANY TOOL IN LIST 1 AND LIST 2, OR,

No. 405 Patent Draftsman's Scale, 12 in.....	\$1.50
No. 380 Steel Straight Edge, 18 in.....	1.80
No. 11 12-in. Combination Square.....	2.00
No. 60 6-in. Reliable Try Square.....	1.25

No. 425 Slide Caliper Rule, 3 in.....	2.00
No. 15 3-in. Universal Bevel.....	1.50
No. 6 Screw Pitch Gage.....	1.50
No. 36 or 37 6-in. Lock Joint Transfer Calipers.....	1.50
No. 186 Drill and Steel Wire Gage.....	1.50
No. 132 6-in. Level.....	1.50

## TOOLS IN THIS LIST FOR FIVE NAMES EACH

ANY TOOL IN LIST 2 AND LIST 3, OR

No. 380 24-in. Straight Edge.....	\$2.40
No. 510 Steel Tape in Leather Case, 50 in.....	4.00
No. 9 12-in. Combination Square Set.....	4.00
No. 33 Hardened Steel Combination Squares, Drop Forged.....	3.00
No. 20 4½-in. Hardened Edge Solid Steel Square	3.50
No. 25 4-in. Caliper Square with Adjustable Screw	4.00
No. 60 Locomotive Guide Liner.....	3.00
No. 57 New Universal Surface Gage, 12 in.....	3.00
No. 97 12-in. Improved Level for Testing Shafting	2.50
No. 197 12-in. Electrician's Level Non-Magnetic	3.50
No. 163 24-in. Draughtsmen's T. Square.....	3.50

## TOOLS IN THIS LIST FOR TEN NAMES EACH

ANY TOOL IN LIST 1 AND LIST 3, OR,

No. 3 1-in. Micrometer in Case.....	\$6.50
No. 113 1-in. Micrometer in Case.....	7.50
No. 2 2-in. Micrometer in Case.....	7.25
No. 124 B. Inside Micrometer.....	6.25
No. 300 Universal Bevel Protractor.....	5.75
No. 196 Universal Dial Test Indicator with Tool Post.....	7.50

Any tool in the Starrett Catalog desired, and not given above, will  
be given as a premium for a club. ∴ ∴ For particulars address

**POPULAR MECHANICS :: Journal Building :: CHICAGO**



## PEANUTS and POP CORN

### A BUSINESS THAT PAYS

Machines are earning  
from \$35 to \$80 per  
week. Catalog Free.

**S. DUNBAR & CO.**  
18 & 20 No. Desplains St.  
CHICAGO



Send for  
Price List.

**GEO.  
STEELE,**  
260  
Clark  
Street,  
Chicago

## CEMENT FENCE POSTS



Cheap as wood, and will last forever. Made with simple  
and inexpensive tools. Fire Proof, Frost Proof, Wind  
Proof. Material used—Cement and Sand or Gravel. Will supplant Wood and Iron  
entirely. For partic- Chamber of  
ulars write with stamp **A. D. MACKAY & CO.,** Commers, Chicago.



## Tools

Every me-  
chanic  
should  
have a  
copy of

our large 600 page catalogue  
in his tool kit. The largest  
retail hardware stock in the  
world at your command.

Everything for all trades at wholesale prices.  
We carry both the medium and the very best  
grades. Ask for 600 page Mechanics Cata-  
logue. Free to any address.

**Montgomery Ward & Co.**  
Michigan Ave., Madison and Washington Sts., Chicago

## What Is Daus' Tip-Top?



**TO PROVE** that Daus' "Tip-Top" is  
the best and simplest device for mak-  
ing 100 copies from pen-written  
and 50 copies from typewritten origi-  
nal, we will ship complete dupli-  
cator, cap size, without deposit  
on ten (10) days' trial.

Price \$7.50 less trade  
discount of 33 1/3%, or **\$5 net**

**THE FELIX S. K. DAUS DUPLICATOR CO.**  
Daus Building, 111 John St., New York City

## RUBBER STAMPS

A profitable line  
to manufacture.  
We sell outfits for  
making them  
from \$25 up.

SEND FOR PARTICULARS

**WM. A. FORCE & COMPANY, Inc.**  
188A Monroe St., Chicago, Ill.

# The Overland Limited California

the most luxurious train in the world,  
leaves Chicago 8:00 p. m. daily. Less  
than three days to San Francisco,  
Magnificent equipment. Electric lighted  
throughout.

### THE BEST of EVERYTHING

Two other fast trains leave Chicago 10  
a. m. and 11:35 p. m. daily, with through  
service to San Francisco, Los Angeles  
and Portland via the

**Chicago & North-Western,  
Union Pacific and  
Southern Pacific Railways**

All agents sell tickets via  
this route.

Illustrated booklets on  
application to  
**W. B. KNISKERN,**  
CHICAGO, ILL.  
or **E. L. LOMAX,**  
OMAHA, NEB.

OL16

# INDUSTRIES ARE OFFERED LOCATIONS

WITH

Satisfactory Inducements  
Favorable Freight Rates  
Good Labor Conditions  
Healthful Communities

ON THE LINES OF

**THE ILLINOIS CENTRAL R. R.**

AND THE

**YAZOO & MISSISSIPPI VALLEY R. R.**

For full information and descriptive pamphlet, address

**J. C. CLAIR**

Industrial Commissioner

1 Park Row, - - - Chicago, Ill.



**"Want" and "For Sale" Ads. 2 cents per word, payable in advance. Replies may be sent to a number, care Popular Mechanics, and will be forwarded promptly without extra charge.**

**"SHOP NOTES"—Cloth \$1, paper covers 50 cents. Popular Mechanics.**

### AUTOMOBILES.

**ONE ORIENT MOTOR BUCKBOARD**, latest model, used about three weeks, perfect condition. I have no longer use for an automobile. Price \$125.00 f. o. b. Shreveport. R. C. Bradley, Shreveport, La.

**AUTOMOBILE GEAR** to exchange for anything useful; worth \$150. A. P. C., 10 S. Wall St., Columbus, Ohio.

**FOR SALE—A new Mobile Steamer** at half price. Address C. H. Benford, Shenandoah, Iowa.

**AERMOBILE—Capital Wanted to Develop.** Utilizes a powerful natural force that takes the place of gas and the aeroplane for uplift and revolutionizes balloon and airship construction. Action wholly mechanical. Every atom of motor energy converted into its equivalent of uplift and propulsion. No gas bag, no bulk to overtax the motor. Small and compact in form, simple and inexpensive in construction. Belongs in the class of true invention, not a workshop mountain bringing forth a mouse after hard labor. Can take care of itself in the wind, rise and descend at will and maintain any desired level. Force employed well known and can be developed to practically unlimited extent by simple devices and can be directed by a single lever to execute with precision every movement required for successful air flight. Address Box 47, Winchester, Tenn.

### FOR SALE.

**FOR SALE—Two gasoline launches** one 33 ft., 7 ft. beam, 12 h. p. jump spark engine, with cabin. Will sell for \$500 spot cash. The other a 24 ft. 7½ ft. beam, 6 h. p. Miamus gray engine, sell for \$275, or both for \$750. Write for further particulars to P. E. Vaninwigen, 52 Front St., Newburgh, N. Y.

**FOR SALE—The best car mover on earth.** Good opening for agents as side line. Write us for circular, explaining the Badger Car Mover. Price \$5 f. o. b. Appleton. Western Specialty Co., Appleton, Wis.

**FOR SALE—Incandescent battery lamps** from 1½ to 220 volts and candle power from ¼ to 100; 40c each and base 10c. Discount given on dozen lots. Smith Bros.' Electric Supply House, 363 W. Van Buren St., Chicago.

**FOR SALE—Mechanical-Electrical scholarship** (correspondence). Armour Institute of Technology, with 10 volumes reference library. Sold at \$65, will take \$45 cash, or \$47.50 installments for books and course. B. Bean, 16 Wisconsin St., Chicago.

**FOR SALE—A No. 8 45-inch blower** in first-class condition. Manufactured by the Champion Blower & Forge Co. of Lancaster, Pa. Eureka Foundry Co., Rochester, N. Y.

**FOR SALE—a course in electric power and lighting** cheap. F. C. S., Wm. Gunkel, Jr., 782 W. 12th St., Chicago.

**FOR SALE—One Davis Gasoline Engine, 22 H. P.,** as good as new. Price \$300.00. Oregon Self Preder Co., Oregon, Wis.

**FOR SALE—A specialty** which pays manufacturer 100 per cent profit; can be made in almost any shop; patent has 14 years to run; will sell patent, dies, and a good trade already established. Owner is located on Pacific coast and does not wish to change residence. Address 760, care Popular Mechanics.

**FOR SALE, BARGAINS—Foot Power Lathe,** two speeds for wood, brass and ivory turning, metal boring; will turn four feet long between centers; eleven-inch swing; iron head and foot block, babbitted boxes, wooden frame, metal runway for foot block, two iron rests, centers, face plate; emery wheels for polishing; used by gunsmith for general repair work. Complete \$20.00. Foot power mortice machine, one cutter, iron frame, wooden spring, similar in general make to Barnes and Seneca Falls Co.'s morticers; \$15.00. Both machines are in perfect working order and good practical tools. Prices include careful packing and on board cars at Peoria. Apply to W. N. Fisher, 830 Bigelow St., Peoria, Ill.

**FOR SALE—Second-hand 5 h. p. air-cooled auto engine,** \$65. Good as new. W. Hoffman, 1253 North Halsted St., Chicago.

**FOR SALE—One Troy mangle, 16x75; one Cambridge extractor, 20-inch; one Knudtson combined C. & C. ironer, 18-inch roll; one Empire combined shirt ironer; one Hagen combined S. & B. ironer, 6x36-inch.** Above machines in A 1 condition, at a rare bargain. Address Spring City Laundry, Waukesha, Wis.

**TO EXCHANGE—For city property,** a beautiful farm of 88 acres with all kinds of buildings in good repair. For particulars address P. E. Vanlawegen, No. 52 Front St., Newburgh, N. Y.

**YOUNG MAN** studying correspondence course wants situation in electrical shop so as to learn Electrical Engineering. Had two years' experience as machinist. 760, care Popular Mechanics.

### FOR SALE—BARGAINS.

Hamilton Corliss Engine, 20x42.  
Vilter Corliss Engine, 12x30.  
Erie City Automatic Engine, 16x24.  
Buckeye Automatic Engine, 14x16.  
M. A. Green C. C. Automatic Engine, 13x12.  
Watertown C. C. Automatic Engine, 9x10.  
Sturtevant C. C. Automatic Engine, 8x10.  
L. D. POLLARD, 48 S. Jefferson St.,  
Chicago, Ills.

### BUSINESS CHANCES.

**WANTED—MECHANICAL PARTNER—I** have been engaged for the past year in manufacturing a machine for which there is a very large and growing demand. The work is such that I desire the co-operation of some bright experienced mechanic to join me. Only a few hundred dollars required; 200 per cent profit in the business. Address, 768, care Popular Mechanics.

**YOU GET SOMETHING** of everlasting benefit when you order our business penmanship course. Best published. Used in many schools. Complete set of lessons for home practice, 50 cts.; with personal mail instruction, \$1.00. Order now; stamps taken. Rasmussen School of Penmanship, Globe Bldg., St. Paul, Minn.

**WANTED—Inventor of a number of cement articles** would like to correspond with capitalists desiring to start a factory manufacturing posts, porch pillars, etc. Address Box 443, Sturgis, Mich.

**BE A MINE OWNER—Why not,** when we can sell you a mine from two hundred dollars and upwards. We have sold some of the largest mines in Butte the last twenty-four years. Mines suitable for working or stocking. One of our bargains. Twenty acres three miles from Butte in the rich copper belt; has splendid showing; ground patented. Price only \$2,000. Write for list. Cobban Realty Company, Butte, Montana.



**BUSINESS CHANCES—CONTINUED.**

**FOR SALE—FOR ONE DOLLAR—**Sir and Brother Smith: I have been a factory steel worker forty years, and these are best methods used by expert smiths I have met. The New Treatise on New Steels explains all the new steels and tells how to work them successfully. Also seventy-five new methods of forging and welding on machine and plow work, making all difficult jobs easy, with ten receipts for making your own welding compounds for welding the different kinds of steel solid and no time wasted. You can make money making and selling to blacksmiths some of these compounds. Thermite welding fully explained; it welds railroad rails in the twinkling of an eye; this is very valuable to understand. Also two hand-colored Tool Tempering charts. Chart A explains all annealing and hardening. Chart B explains both scientific and plain tempering to a standard in oil, water or tallow, showing true color each tool should be and telling what it will stand. All the above for One Dollar, and any one buying these and not satisfied I will return his money free. Yours respectfully, W. M. Toy, Sidney, Ohio. Samples free.

**RE-SILVER OLD MIRRORS,** at 10c. Brings you \$5.00. One agent made \$7.80 with an outlay of \$45c. We have 20 other Practical Money-making Methods for lady or gent agents. Prospectus and list of present students for stamp. Hullinger's Art School, Francesville, Ind.

**WANTED.**

**WANTED—**Young men to learn Telegraphy and R. R. Accounting. Our graduates receive from \$50 to \$150 per month. Endorsed by all railroads. Write for catalogue. Morse School of Telegraphy, Cincinnati, O., Elmira, N. Y., La Crosse, Wis., Atlanta, Ga.

**ONE YEAR'S SUBSCRIPTION** to Popular Mechanics to anyone sending me "Automobile," Oct. 1900. Mrs. C. F. MacDermot, Hotel Touraine, Boston, Mass.

**WANTED—"Automobile,"** Oct. 1900, back numbers "Motor Vehicle Review" 1902, "Motor Age" 1900-1901. Write to Mrs. C. F. MacDermot, Hotel Touraine, Boston, Mass.

**HELP WANTED.**

**ONE MECHANIC** in every shop to earn good money. Address "Money," care Popular Mechanics.

**WANTED—**Mechanists having ability and tact, to teach partly experienced men ways to get the best results from drilling, milling, turning and other tools. A capable man will have steady employment at from \$25.00 to \$30.00 weekly. Address Thomas B. Jeffery & Co., Kenosha, Wis.

**FARM PROPERTY.**

**FOR SALE—**Illinois farm; 323 acres; black rich bottom land; clay subsoil; all can be plowed; no better corn land in the state; good buildings; fenced and crossed with Page woven wire; rural free delivery; long distance telephone; good gravel roads to city of 2,500 population. Home market for all farm products. Borden's Condensed Milk Factory. The price paid for milk for past six months, \$4.50 per 100 lbs. Good school and creamery one-half mile from farm—6 miles northwest of Chicago. If sold quick will take \$80 per acre. Part cash. Address, 766 Popular Mechanics.

**PATENTS**

**PATENTS SECURED** through Popular Mechanics Patent Bureau promptly. Charges reasonable. If you have a new idea or invention write us regarding it. We will answer promptly and fully without charge. Address Popular Mechanics Patent Bureau.

**MISCELLANEOUS.**

**CASH, OR WILL EXCHANGE** for kodak or guns, complete lessons "Metal Mining," International Correspondence Schools; cost \$65. Lessons on "Cyanide Process;" cost \$15. Blow pipe outfit; cost \$15. Complete drawing outfit; cost \$10. Address "Mining Engineer," care Popular Mechanics.

**BRAINS FOR SALE—**Do you want a prospectus written and illustrated for your new company or syndicate? Do you want one that will command attention and sell shares? Do you need a catalogue or booklet that will not be thrown in the waste basket? If so write to Expert, care of Popular Mechanics, Journal building, Chicago.

**WHEN YOU WANT** anything and don't know where to get it, write Popular Mechanics.

**THE FRACTOMETER** will instantly solve all problems in addition or subtraction of fractions and their decimal equivalents. Every person has need for this wonderful invention, especially Draftsmen, Engineers and Mechanics. Price 50c postpaid, or given free with a year's subscription to Popular Mechanics at \$1 per year. Popular Mechanics, Journal Bldg., Chicago, Ill.

**DEATH** is said to be pleasant when it takes place by drowning; however, we do not believe you want to die that way. "How to Swim" is the book that will teach you how to swim. Contains 100 illustrations; sent postpaid for \$1. Popular Mechanics.

**BINDERS—**Will hold Popular Mechanics 12 issues. Sent postpaid on receipt of 50 cents. Address Popular Mechanics.

**IF YOU WISH** to buy anything or have something manufactured and don't know where to get it, write Popular Mechanics, Journal Bldg., Chicago.

**GAS BALLOONS** bought, sold, made; any size. Carl E. Myers, Supt. Aeronautical Dept., St. Louis, Mo., Exposition. Address, with stamp, Balloon Farm, Frankfort, N. Y.

Five years subscription for three dollars. Popular Mechanics Co. make this offer. A great many people are taking advantage of it. It's open to you also.

**"TIZ-IT"**—If you want to obtain the best possible results from your Phonograph you must use Tiz-It, the new All-Metal-Ball-And-Socket-Swivel-Joint sound improving Horn Connection. Fits all Edison machines and new style Columbia. Price 50 cents. Send for circular. Address J. W. Kreiling Company, 855 North 40th Ave., Chicago.

**HOW TO BRAZE CAST IRON.** Send 25c to B. G. Raymond, Puyallup, Wash.

**MAKE SMOKELESS POWDER** at 10c. Guaranteed; full instructions for \$2.00. Smokeless Powder Co., Francesville, Ind.

**A MOVING-PICTURE MACHINE,** 400-ft. moving picture film, a stereopticon, 150 slides, a 12x12 ft. screen, and a calcium light outfit, including gas tank and gas making apparatus. Used but very little. Cost \$250. Will exchange for automobile, motorcycle or engine lathe. Address 295, care Popular Mechanics.

**ARE YOU LOOKING FOR MODEL CASTINGS?** We have them and two stamps will bring price and circular. Steam engines and boilers any size, and for any service. Lathes and gasoline engines. Sallneville Model & Machine Works, Sallneville, O.

**RE-INK YOUR OLD TYPEWRITER RIBBON** at a cost of 2c. Big money for agents. I instruct you and guarantee you success for \$3.00. It is worth \$20.00 to agents and \$10.00 to stenographers. L. C. Hulliger, Francesville, Ind.



**DOUBLE  
YOUR  
MONEY**

The quickest way to double your money is the best investment, if it's safe and sure. A satisfied person with experience, to whom you may refer, is one way to be sure that it's safe and quick.

**TO MAKE MONEY  
TO MAKE IT QUICKLY  
THAT'S THE POINT**

Let us show you by evidence that

**MILLS  
New Amusement  
MACHINES  
Are MONEY MAKERS**  
—and will pay for themselves in from five days to five weeks

**DOUBLE  
YOUR  
MONEY**

**OUR NEW PLAN INSURES SUCCESS!  
BOOKLET No. 2 TELLS ALL ABOUT IT**

**MILLS NOVELTY COMPANY**  
11-23 So. Jefferson Street - - CHICAGO

**WHEN YOU WANT ANYTHING  
AND DON'T KNOW WHERE TO FIND IT  
WRITE POPULAR MECHANICS**

## FIGHTING ROOSTERS

Mystify and amuse your friends. These are two genuine game roosters with feathers, they fight to a finish, and are always ready to fight. The secret of their movements is only known to the operator. Will last a lifetime. 1pc per pair, 3 for 25c. Postpaid and our big bargain catalogue free. Address **W. H. MILLER SUPPLY CO., 739 E. 4th Street, St. Paul, Minn.**



## BE YOUR OWN BOSS

**MANY MAKE \$2,000 A YEAR**

You have the same chance. Start a Mail Order Business at home. We tell you how. Money coming in daily. Enormous profits. Everything furnished. Write at once for our "Starter" and FREE particulars.

**P. M. Krueger Co., 155 Washington St., Chicago, Ill**

## BIG MONEY!

Can now be made in certain stocks by anyone with a capital of \$5 to \$10 a month. We are in position to give you the only reliable inside information. Write to-day.

**UNION SECURITY CO.**  
461 Gaff Bldg. CHICAGO, ILL.

**WANTED** 10 men in each state to travel, tack signs and distribute samples and circulars of our goods. Salary \$75.00 per month. \$3.00 per day for expenses.  
**KUHLMAN CO., Dept. E, Atlas Block, CHICAGO**



## "GOOD-BY, MY LADY-LOVE;"

BEDELIA, Narsjo, Laughing Water, Hiawatha, Holy City, Anona, Good Old Summer Time, Mr. Dooley, Go Way Back and Sit Down, Just Next Door, I've Got a Feelin' for You, Bill Dalley, Under the Ambusher Bush, Always in the Way, Under the Bamboo Tree, I'm Wearing My Hat Away for You, 50 LATEST SONGS & MUSIC, pag-tims.com, come, love, war, also a Prize Ticket winning a gold-finished WATCH CHAIN AND CHARM. All for 10 cents; 3 lots 20c. Sing the latest songs and be popular. Address **STAR MUSIC CO. CHICAGO.**



## WATCHED THE HENS

Then used them. Siems, the German Poultry Specialist, uses the hen in his

### Natural Hen Incubator.

Nature's own way, hen instinct, hen work. Cuts high prices. 200 egg hatcher costs but \$3. Agents wanted. Write him to-day. Catalog with 25c. lice formula free.

**Natural Hen Inc. Co., B-27, Columbus, Nebraska.**



## PATENT YOUR IDEAS

\$100,000 offered for one invention; \$5,500 for another. Book "How to Obtain a Patent" and "What to Invent" sent free. Send rough sketch for free report as to patentability. We advertise your patent for sale at our expense.

**CHANDLEE & CHANDLEE, Patent Attorneys**  
918 F Street, Washington, D. C.



## A GOLD WATCH OF MERIT \$5.00

**GUARANTEED FOR 25 YEARS.**

This is a Genuine Gold-Leaf Engraved Watch double hunting case, stem-wind and stem-set and fitted with high-grade ruby jeweled movement. Send your name, P. O. and Express Office address and we will send you the Watch, Watch-Chain and Charm C. O. D. \$5.50 and express charges. Examine before paying express agent a cent. If as represented, pay \$5.50 and express charges and it's yours. Write if you desire Ladies' or Gents' size. Address **SAFE JEWELRY CO., Dept. 114, CHICAGO.**

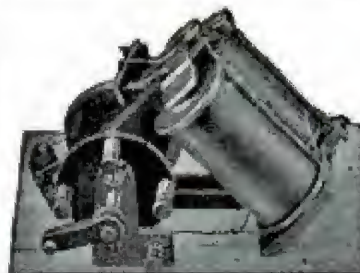

## DO YOU

Desire an even and systematic temperature in your office or home?

You can have it by installing our Champion Electric Regulator. It is automatic in its operation.

Write for Illustrated Booklet

**Champion Electric Heat Regulator Co.**

704 N. Main St., Elkhart, Ind.

## CO-OPERATION

is the mystic key to fortune, fame and happiness. We hold the key, but cannot turn it alone. We will share with you in the greatest money-making co-operative business on earth. We are giving away 250,000 shares of Treasury stock. Par value \$1.00 per share. Not a share can be bought for cash.

### There's 20 Shares for You

No more for anyone. We don't want your money, don't send us a cent, just a postal card. Our plan is unlike that of the trusts who give millions of shares to drones, called "promoters." We are giving ours to partners—energetic men and women. This stock will pay large dividends and costs you—just a little effort—that is all—fortune's knock is at your door, believe it or not, as you please.

**THE PEOPLE'S COMPANY**  
144 West Madison Street, Chicago



# I Turned Out \$301.27



worth of plating in 2 weeks, writes M. L. Smith of Pa. (used small outfit). Rev. Geo. P. Crawford writes, made \$7.00 first day. J. J. S. Mills, a farmer, writes, can easily make \$5.00 day plating. Thos. Parker, school teacher 21 years, writes, "I made \$9.50 profit one day, \$9.35 another." Plating Business easily learned. **We Teach You Free—No Experience Required.** Everybody has tableware, watches, jewelry and metal goods to be plated with Gold, Silver, Nickel and Metal plating. **Heavy Plate**—latest process. No toy or humbug. Outfits all sizes. Everything guaranteed. **LET US START YOU.** Write today for Catalogue, Agency and Offer. Address, **F. Gray & Co., Plating Works, Cincinnati, O.**

## HINTS TO INVENTORS.

We owe our civilization to inventions; but for the inventor we would still paddle in a canoe, chop wood with a stone ax, and plow with a forked stick. In fact, all our conveniences and luxuries are due to the inventor.

Nearly all the wealth of the world is due to inventions, yet the inventor has not had his just share of this wealth. A patented invention which fills a need of the people or of the manufacturing world is a valuable property capable of yielding large returns if it is handled wisely and well; if it is brought before the right people in the right manner. Right here is where the inventor usually makes a mistake. The reader, no doubt, has either experienced himself or has personal knowledge of an inventor who has worked hard to produce an invention only to see it enrich others while he received nothing.

To get a manufacturer to handle an invention is as big a job as inventing a complicated machine, and is invariably harder for the inventor to accomplish when proceeding single-handed.

There are two kinds of inventors, each necessary to the other; and the one invents the device, and the other invents the method by which men will be brought to think favorably of it.

Manufacturers do not like to experiment. Those with whom a royalty contract would be valuable prefer to confine their efforts to making and selling only the goods that have been demonstrated in active use to be valuable, both as to practical working of the device and its value as a seller. Right here lies the mission of the man who can reach the proper manufacturer and the public, either by special facilities or special fitness, or both, for new and valuable inventions do not introduce themselves; those of the highest order of merit frequently have to be forced upon the market.

In this day of large factories and strong competition, articles of manufacture must be made in large quantities, and frequently proper machinery for making them must be supplied.

Very few inventors have the facilities or the fitness to give a commercial value to their inventions. Inventions are often made by those whose occupation is outside of the business to which their invention pertains, and the inventors are unable to devote the time necessary to market their inventions. If you have an invention which you believe to be useful and marketable, write to us and tell us about it and let us tell you what we think about it. This will not cost you a cent, and you will at least get some valuable information. It will cost you nothing to know what we believe can be done with your invention.

Write us to-day, not to-morrow.

**POPULAR MECHANICS PATENT BUREAU,**  
Journal Building,  
Chicago, Ill.



**BIG MAIL FREE** If you wish to get thousands of FREE samples of books, pictures, cards, songs, jewelry, tricks, medicine, soap, seeds &c. and a set of papers, magazines, catalogs, circulars and agents' outfits, from firms all over U. S., send 10 cents to have your name put in the **STAR AGENTS' DIRECTORY.** To get 100,000 names quick we send free 6 Agents' Articles worth \$1, Map of U. S., 42 Games/Puzzles; 20 Magic Tricks; 19 Comic Recitations; 68 New Jokes; 129 Ways to get Rich; 229 Riddles; 10 Funny Readings; 71 Toasts; 21 Monologues; 15 Card Tricks, \$1. Don't Bill good for one dollar's worth of our goods, and a **GOLD PRIZE TICKET.** Send 10 cents to-day to **STAR DIRECTORY CO. CHICAGO.**



## TYPEWRITERS ALL MAKES

All the Standard Machines Sold or Rented Any Where at Half Manufacturers Prices. Shipped with privilege of examination. Send for cats'g Typewriter Emperium, 198 La Salle St., Chicago



## A Good Printing Outfit for 15c.

With it you can print your own cards, envelopes, or mark linen. Consists of 3 fonts rubber type, luk pad, type holder and tweezers. Price only 15c postpaid. Our new catalog of jewelry, novelties, etc., free for the asking.

**DON'T MISS IT!**

W. H. MILLER SUPPLY CO., 738 E. 4th St., St. Paul, Minn.

## LOW PLUMBING BILLS

Get them by paying right prices for supplies. We sell

## SUPPLIES AT WHOLESALE

You save 20% to 40% on every article. Highest grade goods and line complete. Free illustrated catalog gives all particulars. Write for it.

**B. P. KAROL,**  
229 W. Harrison St., Chicago.

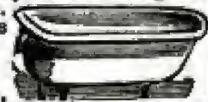

## MEN EVERYWHERE

To learn how to make new and resilver old mirrors. Immense profits in the work and we guarantee you success. We tell free of charge how to emboss, etch, foil, gold leaf, glid, frost and chip glass. Send for particulars and start at once.

**G. L. Patterson & Co., Chicago, Ill.**

HUNTING CASE  
GENTS  
LADIES  
SIZE



## This ELEGANT Watch \$3.75

Before you buy a watch cut this out and send to us with your name and address, and we will send you by express for examination a handsome **WATCH AND CHAIN C. O. D. \$3.75.** Double hunting case beautifully engraved, stem wind and stem set, fitted with richly jeweled movement and guaranteed a correct timekeeper; with long Gold plated chain for Ladies or vest chain for Gents. If you consider it equal to any \$25.00 **GOLD FILLED WATCH** Warranted 20 YEARS pay the express agent \$2.75 and it is yours. Our 20 year guarantee sent with each watch. Mention if you want Gents' or Ladies' size. Address **H. F. FRASSE & CO., 331, 23 Quincy St., CHICAGO.**

## MAKE MONEY

Giving moving picture entertainments.

GET OUR FREE CATALOGUE NO. 40

**EUGENE CLINE & CO.**

10 E. 14th St., New York City 59 Dearborn St., Chicago

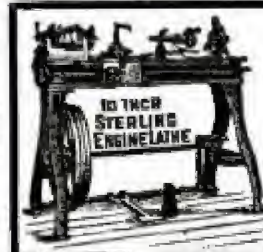

## ASTONISHING VALUE

Screw Cutting Lathe, 10-in. swing, 4 ft. bed, Hollow Spindle; Steady Rest, Centers, Face Plate, Cuts Right and Left Threads 7 to 48, Easy Running Foot Motion, Accurate, Cheap.

Cut out this advertisement and get 1846 Catalogue Free, otherwise 25 cents will be charged.

**H. F. FRASSE CO., 38 Cortlandt St., N. Y.**



## THE "NULITE" VAPOR GAS LAMPS

AGENTS ARE COINING MONEY

A 24th-Century evolution in the art of lighting. Entirely new, 100 candle power, 7 hours one cost. Superior to electricity or gas and cheaper than coal oil. No trouble to keep clean, absolutely safe. Sells at sight. We also manufacture table lamps, wall lamps, chandeliers, stove and stove lamps. Agents wanted at once. Write for free catalogue and prices. We manufacture all kinds and grades of man-leaf. If you buy them direct from us we will save you dealers' profits. Prices sent upon request.

**Chicago Solar Light Co. Dept. C. Chicago**



# Popular Mechanics Book Department

We can furnish any book published. Books in the following list sent prepaid on receipt of price, or for the number of New Yearly.

Subscribers stated. The sender of the club may include his own subscription in clubs of three or more.

## ARCHITECTURE BUILDING, PAINTING, ETC.

**Steel Square, Treatise of the Practical Uses of,** by Fred T. Hodgson, Architect. New and up-to-date. Published May 1st, 1903. Do not mistake this edition for the one published over twenty years ago. This is the latest practical work on the Steel Square and its uses published. It is thorough, accurate, clear and easily understood. Confounding terms and phrases have been religiously avoided where possible, and everything in the book has been made so plain that a boy twelve years of age, possessing ordinary intelligence, can understand it from beginning to end. Cloth, 2 volumes, 560 pages, 500 illustrations, price \$2.00. Given for 3 subscriptions.

**Hodgson's Modern Estimator and Contractor's Guide,** for pricing all builders' work, with many tables, rules and useful memoranda, by Fred T. Hodgson. This work contains a concise explanation of the various methods of estimating builders' work by the square, by the cubic foot, by rough quantities, by accurate quantities and other methods. The mason, the plasterer, the bricklayer, the carpenter, the excavator, the plumber and, in fact, the representative of every trade that has anything to do with building will find rules and methods given in this volume for estimating the cost of work he is tendering for. Cloth binding, 300 pages, 200 illustrations, price \$1.50. Given for 3 subscriptions.

**Modern Carpentry and Joinery,** a practical manual for carpenters and woodworkers generally, by Fred T. Hodgson, Architect. A new, complete guide, containing hundreds of quick methods for performing work in carpentry, joining and general woodwork. Like all of Mr. Hodgson's works, it is written in a simple, every-day style, and does not bewilder the working-man with long mathematical formulas or abstract theories. The illustrations, of which there are many, are explanatory, so that any one who can read plain English will be able to understand them easily and to follow the work in hand without difficulty. Cloth binding, 256 pages, 230 illustrations, price \$1.00. Given for 2 subscriptions.

**Hodgson's New Hardwood Finishing,** by Fred T. Hodgson. A practical treatise on wood finishing in all its branches, including tools and materials employed, preparation of surfaces, stains and staining, fillers and filling, shellacking, varnishes and varnishing, rubbing, polishing, French polishing, wax polishing, oil polishing, etc., etc. Also a full description of the woods employed in wood finishing, their treatment, and the finishing of floors. Cloth, 320 pages, 100 illustrations, price \$1.00. Given for 2 subscriptions.

**Radford's American Ideal Homes,** containing 100 house plans, 200 illustrations, 250 pages, cloth, price \$1.00. Given for 2 subscriptions.

**American Ideal Homes,** edited by Radford, illustrating 100 buildings with plans and perspective views, size 8 by 11, 108 pages, price \$1.00. Given for 2 subscriptions.

**Burnham's Practical House Builder,** with plans and specifications, by H. E. Burnham, 100 illustrations, paper cover, price 25 cents; cloth cover, price 50 cents. Given for 1 subscription.

**Estimating Frame and Brick Houses,** by Fred T. Hodgson, 224 pages, with scale drawings and other illustrations, price \$1.00. Given for 2 subscriptions.

**Barn Plans and Out Buildings,** for the construction of barns, etc., 256 illustrations, cloth, price \$1.00. Given for 2 subscriptions.

**Common Sense Stair Building and Handrailing,** by Fred T. Hodgson, M. O. A. A. Handrailing—Showing three of the smallest methods known in the art, with complete instructions for laying out and working handrails suitable for any kind of stairs. Stair Building—Section four of the work, which covers upwards of 80 pages, is devoted to newel or platform stairs chiefly, and gives instructions for their building, planning and decoration. Cloth, 256 pages, 230 illustrations, price \$1.00. Given for 2 subscriptions.

**Builders' Architectural Drawing Self-Taught,** by Fred T. Hodgson. This work is especially designed for carpenters and architects and other wood workers who desire to learn drawing at home, and who have not the means, time or opportunity for taking a regular course in school or college, or availing themselves of the offers made by one or other of the "Correspondence Schools." This valuable work contains over 300 pages printed from new large type on a superior quality of cream wove paper. Over 300 fine line engravings made especially for the work, each drawn to scale, 18 large double folding plates with full explanation for each. Also contains perspective views and floor plans of 50 low and medium priced houses. Cloth, price \$2.00. Given for 3 subscriptions.

**Hodgson's Low Cost American Homes,** arranged and edited by Fred T. Hodgson, M. O. A. A. This book contains perspective views and floor plans of one hundred houses, churches, schoolhouses and barns, and is, without a doubt, the most practical work ever issued. The plans shown have been built from, and many of them duplicated many times over. All are practical, the creation of the well-known author, including many other architects throughout the United States and Canada. Cloth, 220 pages, 200 illustrations, price \$1.00. Given for 2 subscriptions.

## PAINTS AND PAINTING.

**The Painters' Encyclopedia,** containing definitions of all important words in the art of plain and artistic painting, with details of practice in coach, carriage, railway car, house, sign and ornamental painting, including graining, marbling, staining, varnishing, polishing, lettering, stenciling, gliding, bronzing, and valuable hints and helps in scene painting, porcelain painting, plain painting, distemper painting, and all work in which a brush, pencil or palette is used, by Franklin B. Gardner. Cloth, 426 pages, fully illustrated, price \$1.50. Given for 2 subscriptions.

**Practical Carriage and Wagon Painting,** a treatise on the painting of carriages, wagons and sleighs, embracing full and explicit directions for executing all kinds of work, including painting factory work, lettering, scrolling, ornamenting, varnishing, etc., by M. C. Hillick. Cloth, 160 pages, fully illustrated, price \$1.00. Given for 2 subscriptions.

**The Signist,** new, original, up-to-date. These designs have been prepared especially for this book by a master in each special line, all of which are replete with helpful suggestions of new and practical ideas, which the skilled mechanic or the beginner may amplify to almost an unlimited extent. In the preparation of this book no expense has been spared to produce a standard text-book of original art gems which shall adequately supply a long-felt want. Paper cover, price \$1.50. Given for 3 subscriptions.

## ENGINEERING.

**The 20th Century Hand Book for Steam Engineers and Electricians,** with questions and answers, by C. E. Swingle, M. E. This is the very latest and best book on engineering and electricity for the beginner, practical engineer or electrician published. It is written in a purely self-educational style, so that any one with but a limited education can understand it. Illustrated with hundreds of fine engravings, showing every working part of an engine or boiler, dynamo, etc., 600 pages, size 5x7, durably bound in full leather, pocket book style, red edges, price \$2.50. Given for 4 subscriptions.

**Farm Engines and How to Run Them—The Young Engineer's Guide,** by James H. Stephenson and other expert engineers, fully illustrated with about seventy-five beautiful woodcuts, a complete instructor for the operator or amateur. This book was the only one out of several that was accepted by 17 state agricultural colleges as a text-book for use of students in farm machinery. 12mo, cloth, 224 pages, price \$1.00. Given for 2 subscriptions.



**Modern Air Brake Practice, Its Use and Abuse**, by Frank H. Dukessmith. The new air-brake book. Invaluable to trainmen, engineers, firemen, conductors, electric motormen and mechanics. The latest and best 1904 edition. With questions and answers for locomotive engineers and electric motormen. While there have been many air-brake books written, we feel safe in saying that never before has the subject been treated in the same lucid, understandable manner in which our author has treated it in this new book. The book is fully indexed and cross-indexed, so that any subject can be turned to immediately, as desired. If you are already posted, you can become better posted. If you really want to know all that is worth knowing about air-brake practice send for this book. 12mo, cloth, 303 pages, hundreds of illustrations, price \$1.50. Given for 3 subscriptions.

**The Locomotive Up-to-Date**. The greatest accumulation of new and practical matter ever published treating upon the construction and management of modern locomotives, both simple and compound, by Chas. McShane. Cloth, 736 pages, 330 illustrations, price \$2.50. Given for 6 subscriptions.

**The Practical Gas Engineer**, by E. W. Longanecker, M. D. A manual of practical gas and gasoline engine knowledge, covering errors to be avoided in the construction of, and how to correct, operate and care for gas and gasoline engines. Every user of a gas engine needs this book. Simple, instructive and right up-to-date. Full of general information about the new and popular motive power, its economy and ease of management. 16mo, cloth, 150 pages, fully illustrated, price \$1.00. Given for 2 subscriptions.

### ELECTRICITY.

**Modern Wiring Diagrams and Descriptions—New 1904 Edition**, a handbook of practical diagrams and information for electrical workers, by Henry C. Horstmann and Victor H. Tousley, expert electricians. This grand little volume not only tells you how to do it, but it shows you. It shows you how to wire for call and alarm bells, for burglar and fire alarm; how to run bells from dynamo current; how to install and manage batteries; how to test batteries; how to test circuits; how to wire for annunciators, for telegraph and gas lighting; it tells how to locate "trouble" and "ring out" circuits; it tells about meters and transformers; it contains 30 diagrams of electric lighting circuits alone; it explains dynamos and motors, alternating and direct current; it gives ten diagrams of ground detectors alone; it gives "compensator" and storage battery installation; it gives simple and explicit explanation of the "Wheatstone" Bridge and its uses, as well as voltmeter and other testing; it gives a new and simple wiring table covering all voltages and all losses or distances. 16mo, 160 pages, 200 illustrations, full leather binding, round corners, red edges, size 4x6, pocket edition, price \$1.50. Given for 3 subscriptions.

**Electricity Made Simple**, by Clark Caryl Haskins. Just the book for beginners and electrical workers whose opportunities for gaining information on the branches of electricity have been limited. A book devoid of technicalities. Simple, plain and understandable. There are many elementary books about electricity upon the market, but this is the first one presenting the matter in such shape that the layman may understand it and, at the same time, not written in a childish manner. For engineers, dynamo men, firemen, linemen, wiremen and learners. For study or reference. Cloth, 233 pages, 108 illustrations, price \$1.00. Given for 2 subscriptions.

**Dynamo Tending for Engineers, or, Electricity for Steam Engineers**, by Henry C. Horstmann and Victor H. Tousley. It is with a view to assisting engineers and others to obtain such knowledge as will enable them to intelligently manage such electrical apparatus as will ordinarily come under their control that this book has been written. The authors have had the co-operation of the best authorities, each in his chosen field, and the information given is just such as a steam engineer should know. 12mo, cloth, 208 pages, 100 illustrations, price net \$1.50. Given for 3 subscriptions.

**Modern Electricity**, by Henry and Hora. Not only the latest but one of the most elaborate and complete works on this subject. Includes latest achievements of scientific research, with explanation of modern inventions and appliances; 150 illustrations, two special wiring diagrams, free from technical phrases, cloth, price \$1.00. Given for 2 subscriptions.

**Easy Electrical Experiments and How to Make Them**, by L. P. Dickinson. The book is an elementary handbook of lessons, experiments and inventions. It is a handbook for beginners, though it includes, as well, examples for the advanced students. Illustrated with hundreds of fine drawings; printed on a superior quality of paper. 12mo, cloth, 216 pages, 120 illustrations, price \$1.00. Given for 2 subscriptions.

**Practical Compend of Electricity (Vest Pocket Size)**. Electricity in all its branches and applications described in concise and practical manner. Includes directions for wiring and lighting of houses, estimates of cost, etc. 119 illustrations, vocabulary of common technical terms, leather, gilt lettering, price 50 cents. Given for 1 subscription.

**The Motorman's Guide**, by J. W. Gayetty. An invaluable instructor, illustrated. Full instructions about the care and running of cars. The latest and best published. Cloth, price 50 cents. Given for 1 subscription.

**Practical Telephone Handbook and Guide to Telephonic Exchange**. How to Construct and Maintain Telephone Lines, by T. S. Baldwin, M. A., illustrated. Containing chapters on The Use of the Telephone, Series and Bridging Phones, Line Construction, Materials to be Used, Locating and Correction of Faults in Instruments and Lines. This is the best book ever published on farm telephones. It is the only book ever issued which treats the subject exhaustively and comprehensively. It is of inestimable value to promoters of rural party lines, because it contains all of the arguments that are necessary to show the advantage of rural party lines. It also tells how such lines should be constructed and cared for. Cloth, 180 pages, fully illustrated, price \$1.25. Given for 3 subscriptions.

**Telegraphy Self-Taught**, a complete manual of instruction, by Theodore A. Edison, M. A., instructor at American School of Telegraphy, illustrated. In this valuable volume will be found everything that is necessary to the study of telegraphy. Though telegraphy is essentially a matter of practice, it has been the aim of the author to present to those who aspire to master the art of telegraphy a book treating the subject in as concise and clear a manner as possible, without eliminating anything that is important, and without putting in things that are detrimental, and which would have a tendency to confuse. Cloth, 160 pages, fully illustrated, price \$1.00. Given for 2 subscriptions.

**The Handy Vest Pocket Electrical Dictionary**, by Wm. L. Weber, M. E. Contains upward of 4,500 words, terms and phrases employed in the electrical profession, with their definitions given in the most concise, lucid and comprehensive manner. The book is of a convenient size for carrying in the vest pocket, being only 2½ inches by 5½ inches, and ¼ inch thick, 224 pages, illustrated, and bound in two different styles. Cloth, red edges, indexed, 25 cents; full leather, gold edges, indexed, 50 cents. Given for 1 subscription.

**Modern Electro-Plating**, by J. H. Van Horne. The only work on the market that gives proper attention to the modern tools, materials and methods used in preparing work for plating. It takes up matters from the beginning and tells how to manipulate articles from the rough casting, forging or stamping, clear through all the processes of polishing, plating, etc., down to the final coat of lacquer. 189 pages, with 27 illustrations, handsomely bound in cloth, with full and complete index, price \$1.00. Given for 2 subscriptions.

### MECHANICS.

**Modern Blacksmithing, Rational Horseshoeing and Wagon Making**, by J. G. Holmstrom. This valuable work is written by a man having thirty years' practical experience. Elementary rules are employed, thus avoiding the more technical terms, rendering this treatise practical and more invaluable to all who have use for it. Even the oldest blacksmith or wagon maker will find many helpful suggestions, and any young man can master the principles of these two useful arts by a careful study of this book. The rules and recipes will be found of great value to farmers, horseshoers, wagon makers, machinists, liverymen, well drillers, manufacturers, as well as amateurs and young men on the farm. Over 200 pages, fully illustrated, price, cloth, \$1.00. Given for 2 subscriptions.

**Hot Water Heating, Steam and Gas Fitting, Acetylene Gas—How Generated and How Used**, by J. J. Lawler and Geo. T. Hanchett. For plumbers, steam fitters, architects, builders, apprentices and householders; containing all modern methods and practical information of all the principles involved in the construction of steam, hot water, acetylene gas plants, and how to properly do gasfitting. Cloth, 334 pages, fully illustrated, price \$2.00. Given for 4 subscriptions.

**American Sanitary Plumbing**, by J. J. Lawler. For plumbers, steam fitters, architects, builders, apprentices and householders. Containing practical information of all the principles involved in the mechanics and science of modern plumbing, illustrating, with original sketches, the fundamental principles of everything the plumber should know. Cloth, 320 pages, fully illustrated, price \$2.00. Given for 4 subscriptions.



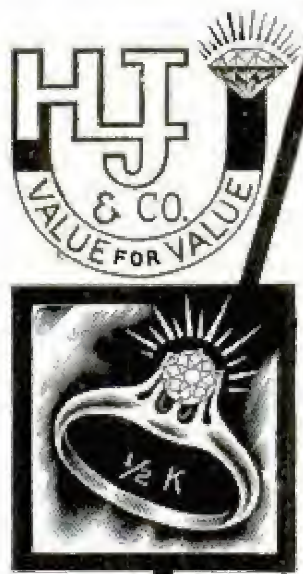

**Diamonds on Credit**  
*"Just the size that satisfies"*  
**1/2 Carat Stone**  
 QUALITY A-1  
**\$65.00**  
 \$10 Down; \$6 Per Month

THE difference between our credit prices and your regular dealer's cash prices is just 10%. Firms who offer to sell on credit at cash prices or less, are unworthy of your confidence. In every "competition shipment," we have gained a new customer. This is a fact—not a claim. We will express ring like illustration to any honest person for inspection, all charges paid. Send first payment with order or ask us to ship ring, C. O. D., \$10. Balance in nine monthly payments. Ring Book No. A 171, shows many styles with weights and prices. If interested in watches, ask for Special Catalog.

**HERBERT L. JOSEPH & CO.**  
 Diamonds—Watches—Jewelry  
 148 A 171 State Street, CHICAGO  
 Responsibility, \$250,000 Established 1882

**"IF SLEEPING, WAKE,**  
 If feasting, RISE before I turn away." It is the hour of FATE 'Tis  
**OPPORTUNITY**  
 the ruler of human destinies, that speaks  
 Of many books there's ONE YOU NEED  
 'Tis unpretentious, and its name?  
**"A Guide to Full Pockets"**  
 That's what most mortals need and if thy needs are common with the rest, here is the mystic key to fortune, fame and joy.  
 'Tis FREE, for fortune's smiles can ne'er be bought. Thousands have read and quickly grasped the offered boon. 'Tis now thy turn—this call the last to you. If heeded not you'll seek in vain for that which will return no more. Send thou a postal card and we will tell thee all.  
**THE NUTRIOLA CO., 142 W. Madison St., Chicago, Ill.**

**50% OFF OUR CATALOGUE PRICES**

Hereafter we will give to the public direct in full all teacher's and dealer's discounts on **VIOLINS, GUITARS, MANDOLINS** and other stringed instruments.  
 A cheap but serviceable instrument listed at \$7.50..... **\$3.75**  
 Our \$21 Lewis Orchestra No. 1 Violin. Our standard for profession and high-grade amateurs; easily worth \$25.00; listed by us for years at \$21.00. Price to dealers and now direct to the public..... **\$10.50**  
 Other instruments, all at 50 per cent off, from \$10.50 and \$25.00 up to..... **\$125.00**  
 We are the largest and oldest exclusive stringed instrument house in the U. S. and import direct from OUR OWN workshops in Erlangen, Germany, and Pavia, Italy. We permit TEN DAYS' TRIAL of any instrument before actual purchase. Write for catalog.  
**WM. LEWIS & SON, 211 B WABASH AVENUE, CHICAGO**  
 Specialty in strings for professional trade.

**\$1 BUYS THE GENUINE Improved Saladin RAZOR**

Hand forged from the finest razor steel in the world. Made and tempered by experts, ground by hand, 5/8 inch blade with double shoulder, set ready for use. Fully warranted.  
**No Better Razor Made at Any Price.**  
 Why pay more when you can get as good as the best for \$1.00. A trial will convince you. Money back if not satisfied. Postpaid On Receipt of Price. Circular and "How to Strip a Razor," sent FREE.  
**HOME MERCANTILE CO., Dept. 30, GROSSDALE, ILL.**

**Bandmen**

Don't buy instruments of any kind until you have seen our prices.  
**\$8.95 Eb Cornet**  
 excellent Windsor model. B♭ Windsor \$9.50. Professional Solo Le Bevre Cornets, twelve models, genuine Courtis instruments. Our illustrated Musical Instrument Catalogue contains everything known in music. Everything from grand pianos to violin strings. Write at once for catalogue and study our wholesale prices. Bandmen particularly should have our catalogue. A postal will bring it.  
**Montgomery Ward & Co.**  
 Michigan Ave., Madison and Washington Sts., Chicago

**PRICE EXPLAINED.**

FOR \$5.00 TO \$8.00 SEWING MACHINES SIMILAR TO THE MACHINE ILLUSTRATED HEREON, HAVE BEEN WIDELY ADVERTISED.

How sewing machines can be offered at these prices and why we can sell the HIGHEST GRADE Sewing Machines made in the world at much lower prices than any other house, is all fully explained in our new big free Special Sewing Machine Catalogue. Cut this advertisement out and send it to us and you will receive, by return mail, free, postpaid, our new big free Sewing Machine Catalogue, showing the most complete assortment of the highest grade Sewing Machines made in the world, all shown in large handsome half-tone and colored illustrations, full descriptions and all priced at prices much lower than any other house can possibly make. With the Big Free Catalogue you will receive THE MOST ASTONISHINGLY LIBERAL Sewing Machine offer ever heard of, a new and marvelous proposition. How others can offer sewing machines at \$5.00 to \$8.00 and why we can sell at much lower prices than all others will be fully explained. We will explain why we can ship your machine the day we receive your order, how we make the freight charges so very low (next to nothing), you will get our FREE TRIAL OFFER, SAFE AND PROMPT DELIVERY GUARANTEE, 20-YEAR BINDING QUALITY GUARANTEE. YOU WILL GET OUR VERY LATEST SEWING MACHINE OFFER. PARTIAL PAYMENT PLAN EXPLAINED. How new sewing machines are exchanged for old ones, all fully explained when you write for Our Free SEWING MACHINE CATALOGUE. HAVE YOU ANY USE FOR A SEWING MACHINE? If you have, don't fail to cut this advertisement out today and mail to us. If you can't use a sewing machine at any price, call your neighbor's attention to this advertisement. Don't buy any kind of a sewing machine at any price, for cash, on time or on installments, or don't trade your old machine for a new one until you get our big new Sewing Machine Catalogue free, with all our new offers, with everything explained, ALL FREE FOR THE ASKING. We will tell you something about sewing machines you ought to know. Write today, and be sure to mention this paper. DO IT NOW. Address,

**SEARS, ROEBUCK & CO., CHICAGO, ILL.**



Men of business prefer The

# California Limited



The train "wears well"; mainly because the service is faultlessly good every mile and every minute.

Santa Fe All the Way--that's the reason.

Daily service will be resumed November 13, superseding present semi-weekly schedule, Chicago to Los Angeles and Frisco.

For pamphlet of the train, and California trip book, address Gen. Pass. Office, A. T. & S. F. Ry., Chicago

Dear Sir:—Would you be open for an investment which will yield, with reasonable assurance, from 50 per cent to 100 per cent each year?

It will average 75 per cent—which means 6¼ per cent a month.

When I say investment, please understand that I do not mean a gambling proposition, such as stocks and grain speculation, or horse-race betting, nor anything which requires you to buy what you do not want, or sell what you have not got.

**I REFER TO A STRAIGHT INDUSTRIAL PROPOSITION**, which has for its commodity products produced by nature, and in turn manufactured into commercial necessities, for which the demand always exceeds the supply.

As a representative business man, I fully realize the annoyance of receiving unsolicited literature and advertising matter of unknown propositions.

Therefore, before placing before you, in full detail, the venture I refer to, I ask your consent, and for that purpose I attach this coupon, which explains itself. If agreeable, and you are open for a proposition which will produce all that I claim, kindly sign and mail it.

**THIS COSTS YOU NOTHING BUT THE POSTAGE, AND PUTS YOU UNDER NO OBLIGATION.**

In closing, permit me to say, that the men at the head of the corporation which I represent are men of great wealth and undisputed commercial integrity.

There is not a single questionable feature in the entire plan.

May I hope to hear from you by return mail?

Very sincerely,

L. C. WELTON, 59 Clark St., Chicago.

### COUPON

Dear Sir:—You may send to my address full details of the proposition you refer to. I will carefully consider the matter, and, if interested, will write you further. This with the distinct understanding that I am under no obligations.

Name ..... Postoffice .....

County ..... Street and No. ....

Date .....1904. State.....



# Try the Victor

At Your Home

Talks  
Laughs  
Sings  
Plays

Special  
Offer  
to  
POPULAR  
MECHANICS  
Readers.



HIS MASTER'S VOICE

**T**O any honest, responsible person we will ship our VICTOR ROYAL TALKING MACHINE and your choice of one dozen Victor Records (lowest net cash price everywhere \$20) **on free trial.**

If not satisfactory after 48 hours' trial, return machine at our expense--we charge you nothing, and refund whatever payment you may have made.

**TERMS OF PURCHASE: \$5.00 down, balance of \$15.00 payable in six monthly installments of**

**\$2.50 A MONTH**

What we are offering is the genuine Victor Royal Talking Machine with one dozen Victor records. You cannot buy this outfit anywhere spot cash for less than \$20.00. Twenty dollars is the price everywhere. Buy direct from us and you can get it on small monthly payments without one cent extra charge.

## REMEMBER:

No guarantees required from third parties; no leases or chattel mortgages, nor interests on payments. You own the instrument when you accept it, and we will trust any responsible party to pay as he agrees.

Don't be misled into buying some toy machine offered at a ridiculous price. There are imitation machines that have to be turned by hand and other cheap instruments that hardly give a sound.

Our Victor Royal Talking Machine has an oak cabinet, spring motor and the VERY BEST REPRODUCER MADE: will play any disc record, and play it beautifully. When you get the Victor, you get the instrument that you can always be proud of.

Write Today for Free Complete Catalogue and List of 2,000 Records

# The Talking Machine Company

Dept. 55, 107 Madison St., Chicago, Ill.

**FREE** To those who already own a Victor: A package of 25 of our new soft-tone needles absolutely free prepaid. These needles give a beautiful, superior, soft, non-scratching sound. Try them. Write for free sample package.

WE PREPAY CHARGES ON VICTOR AND EDISON RECORDS