

DEPARTMENT OF THE ARMY TECHNICAL MANUAL

---

OPERATOR AND ORGANIZATIONAL  
MAINTENANCE MANUAL

ARMAMENT SUBSYSTEM, HELICOPTER,

7.62 MILLIMETER MACHINE GUN:

HIGH RATE, XM27E1

(1005-933-6242)

(USED ON OH-6A HELICOPTER)

This copy is a reprint which includes current pages from Changes 1 through 5.

---

HEADQUARTERS, DEPARTMENT OF THE ARMY

AUGUST 1969

## WARNING

**Warning.** The fairing assembly must be installed for all weapon firing missions, since inflight without ram air duct may result in damage to aircraft tail rotor.

**Warning.** When the GUN NOT CLEARED light is extinguished, the weapon will not fire during manual rotation; however, if the trigger is depressed the weapon will immediately chamber a round and fire.

**Warning.** Do not attempt to perform operational checks with ammunition present in gun, delinking feeder, ammunition chutes, or container.

**Warning.** All ammunition must be removed from all parts of the subsystem prior to boresighting.

**Warning.** Firing shall be accomplished only on approved ranges under the supervision of qualified safety personnel.

**Warning.** A firing pin may be cocked and ready to be released. Before removing safing sector and housing cover, rotate barrels clockwise (opposite firing direction) slightly to prevent firing. Failure to adhere to these instructions explicitly, can result in discharge of the weapon.

**Warning.** Do not attempt to perform maintenance operations on a loaded gun.

**Warning.** Do not attempt to troubleshoot a loaded weapon. Remove all ammunition from the subsystem before applying electrical power.

**Warning.** The use of armor-piercing cartridges is prohibited in demonstrations in which tanks are participating.

**Warning.** The cores of any 7.62 millimeter bullets which fail to penetrate may ricochet up to 100 yards.

**Changes In Force: 1, 2, 3 and 4**

**TM 9-1005-298-12  
C5**

**URGENT CHANGE**

CHANGE

No. 5

**HEADQUARTERS  
DEPARTMENT OF THE ARMY  
Washington, DC, 7 August 1989**

AVIATION UNIT MAINTENANCE MANUAL

ARMAMENT SUBSYSTEM, HELICOPTER,  
7.62 MILLIMETER MACHINE GUN:  
HIGH RATE, M27  
(NSN 1005-00-933-6242)  
(USED ON OH-6A AND OH-58A HELICOPTERS)

TM 9-1005-298-12, 7 August 1969, is changed as follows:

Page 3-19, Table 3-7, Add the following data for Component "Barrel clamp assembly" under the Inspect for column:

3. Prior to assembly of the barrel clamp bolt to the spline nut, test the spline nut for minimum breakaway torque. Install the barrel clamp bolt so that a minimum of one thread extends beyond the spline nut. From a dead stop, apply torque to the bolt using a torque wrench at a slow, steady rate. The minimum breakaway torque shall be greater than 5 inch-pounds. A torque reading less than 5 inch-pounds constitutes a worn spline nut.
4. When conducting prolonged firing with flash suppressor, replace the barrel clamp bolt with a new, like bolt every 10,000 rounds.
5. When conducting prolonged firing without flash suppressor, inspect the barrel clamp bolt every 20,000 rounds.

**By Order of the Secretary of the Army:**

**CARL E. VUONO**  
*General, United States Army*  
*Chief of Staff*

**Official:**

**WILLIAM J. MEEHAN II**  
*Brigadier General, United States Army*  
*The Adjutant General*

**DISTRIBUTION:**

To be distributed in accordance with DA Form 12-31A, Operator and AVUM, requirements for Armament:  
Subsystem: Machine Gun, High Rate, 7.62-MM, M27E1.

CHANGE }  
NO. 1 }

HEADQUARTERS  
DEPARTMENT OF THE ARMY  
Washington, D. C. 8 October 1970

**OPERATOR AND ORGANIZATIONAL MAINTENANCE MANUAL**

**ARMAMENT SUBSYSTEM, HELICOPTER,**

**7.62 MILLIMETER MACHINE GUN:**

**HIGH RATE, XM27E1**

**(1005-933-6242)**

**(USED ON OH-6A AND OH-58A HELICOPTERS)**

TM 9-1005-298-12, 7 August 1969, is changed as follows:

Change the title to read: **OPERATOR AND ORGANIZATIONAL MAINTENANCE MANUAL**

**ARMAMENT SUBSYSTEM, HELICOPTER,  
7.62 MILLIMETER MACHINE GUN:  
HIGH RATE, XM27E1  
(1005-933-6242)  
(USED ON OH-6A AND OH-58A HELICOPTERS)**

Inside cover, warning page; change first warning to read:

**Warning: The ram air duct assembly must be installed for all weapon firing missions, since inflight firing without ram air duct may result in damage to aircraft tail rotor.**

\*\*\*\*\*

**Add the following warnings:**

**Warning: Firing should be accomplished in short bursts as controlled by the three second burst limiter. If combat emergency requires expending a full compliment of ammunition (2000 rounds) by continued recycling of the burst limiter, a minimum of 15 minutes cooling time must be observed before starting to fire the next compliment. Failure to comply with the above procedure will result in possible barrel failure and a definite reduction in barrel life.**

**Warning: Clear all personnel and equipment from firing area. Extreme care must be exercised to ensure that personnel do not walk or stand in front of, or rotate the barrels of, an uncleared weapon when installing the bullet trap.**

\*\*\*\*\*

**Page i:**

## Section X. Maintenance of ram air duct assembly

### Page 1-1:

#### 1-4. Description

The high rate 7.62 millimeter machine gun

helicopter armament subsystem XM27E1 is used on the OH-6A and the OH-58A helicopters. The gun is \*\*\* of the subsystem.

\*\*\*\*\*

*b. (Superseded) Ram Air Duct Assembly (fig. 1-1).*  
The ram air duct assembly is a metal air scoop, consisting of the ram air duct, three turnlock fasteners, retaining cable, two snap fasteners, and a rubber grommet. The retaining cable is attached through the grommet in the ram air duct with a snap fastener on each end. The ram air duct assembly is secured to the link ejection chute by the

three turnlock fasteners and the two snap fasteners. It directs high velocity air into the link ejection chute, insuring that ejected links are thrown clear of the aircraft.

**Warning: The ram air duct assembly must be installed for all weapon firing missions, since inflight firing without ram air duct may result in damage to aircraft tail rotor.**

\*\*\*\*\*

e. The beamsplitter arm \*\*\* not being used.  
(Rescinded)

figure 1-1, WE 66376, Components of armament subsystem XM27E1.

### Page 1-2:

Delete figure 1-1, WE 15616A, and substitute

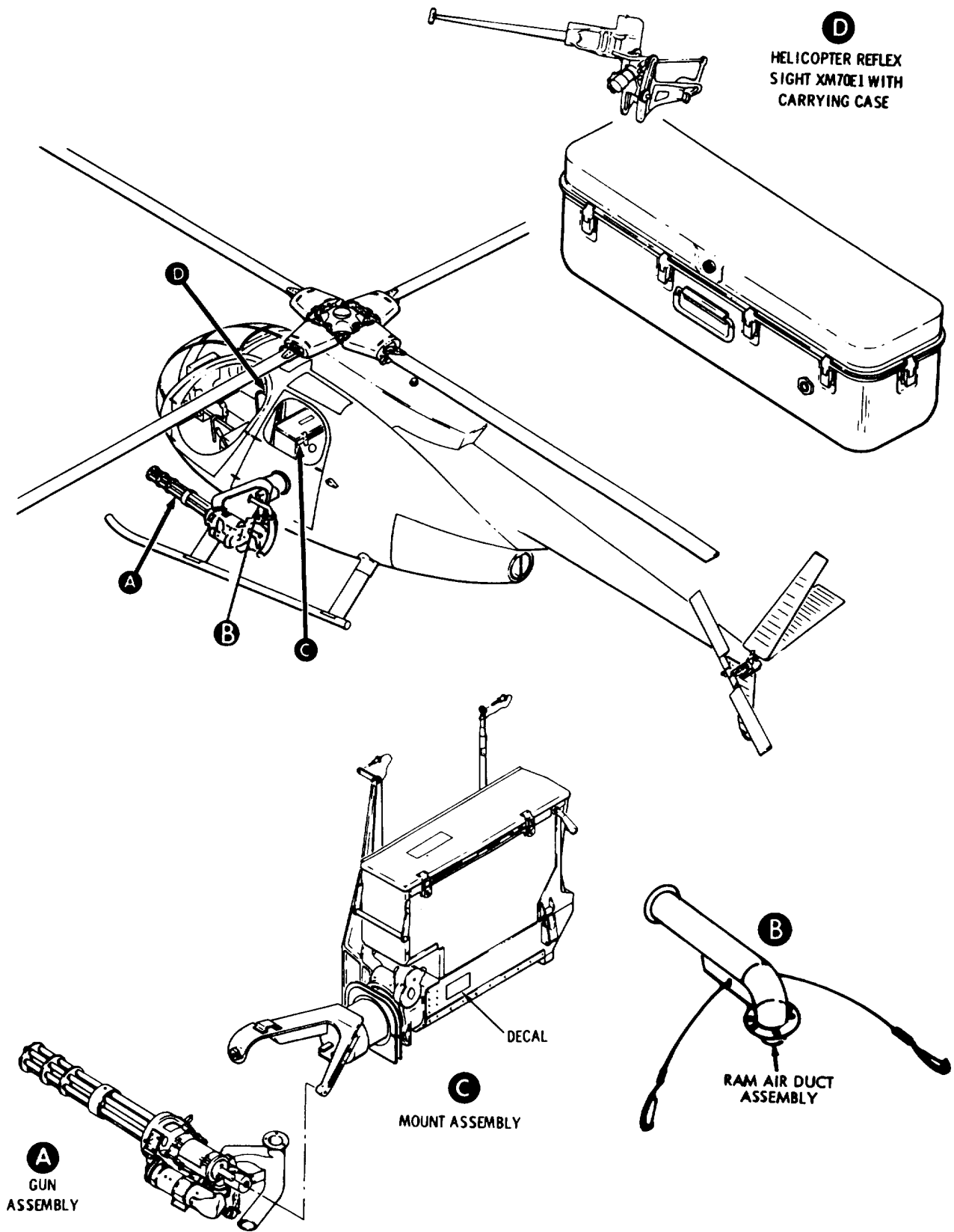

WE 66376

Figure 1-1. (Superseded) Components of armament subsystem XM27E1.

Page 1-3:  
Delete figure 1-2, WE 15628A, and substitute

figure 1-2, WE 66377, Components of gun assembly.

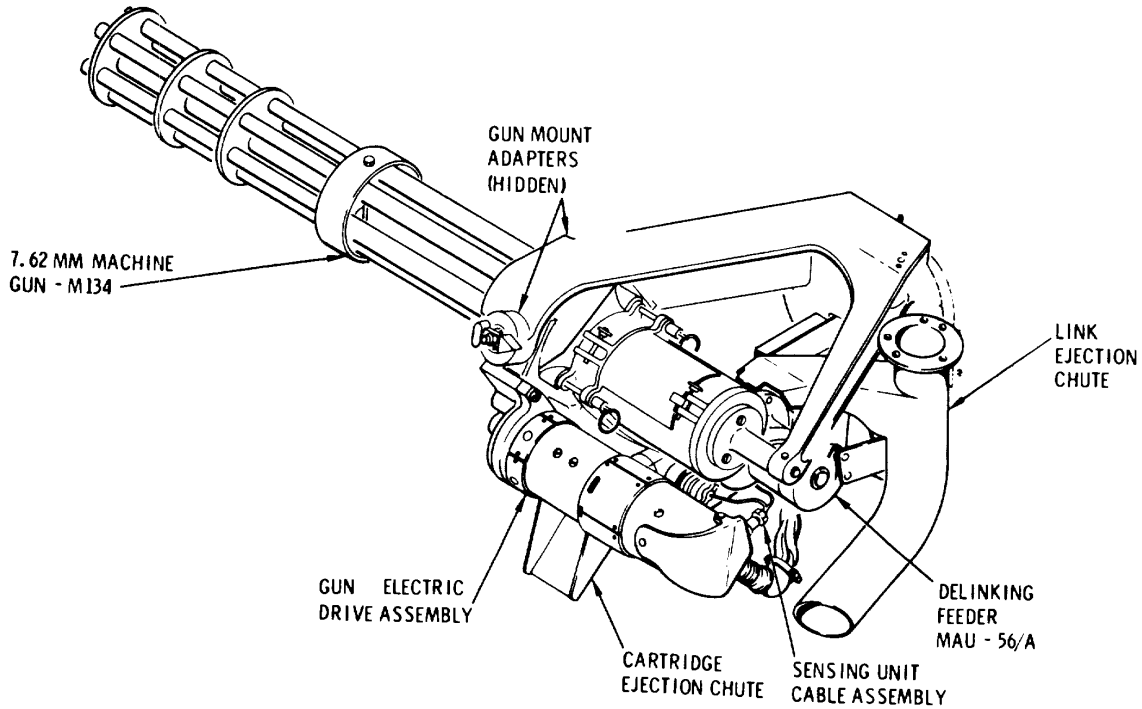

WE 66377

Figure 1-2. (Superseded) Components of gun assembly

Page 1-4:

Table 1-1. (Superseded) Main Components of Armament Subsystem XM27E1

Nomenclature	Quantity Per Subsystem	Fig. No. Reference
Gun Assembly .....	1	1-1
Ram Air Duct Assembly.....	1	1-1
Mount Assembly .....	1	1-1
Reflex Sight Assembly: XM70E1 .....	1	1-1
(w/carrying case)		
Decal.....	1	1-1

Page 1-9:

1-6. Tabulated Data.

a. (Superseded) *Armament Subsystem*.

Weight (subsystem w/o ammunition) .....	110 lb
Weight (subsystem w/ammunition) .....	235 lb
Ammunition capacity .....	2000 rd
Elevation limits OH-6A:	
Elevated.....	10 deg
Depressed.....	24 deg
Elevation limits OH-58A:	
Elevated.....	5.5 deg
Depressed.....	20 deg

\*\*\*\*\*



**Table 1-2. Name, Caution, and Instruction Plates**

Name	Function or use	Location and/or reference
* * * No step decal (Rescinded) Caution decal (Rescinded) * * *	* *  * *	* *  * *

**Page 2-1:**

**2-2. Installation / Removal of Mount Assembly (fig. 2-1)**

\*\*\*\*\*

c. Install two quick-release \*\*\* assembly by lanyards. When the armament subsystem XM27E1 is being mounted on the OH-58A helicopter, the upper mount link is replaced by functional group 30 armament parts (fig. 2-1A) as referenced in TM 55-1520-228-20.

d. Connect electrical plug \*\*\* aircraft canted frame. When the armament subsystem XM27E1 is mounted on the OH58A helicopter, an extension cable assembly (fig. 2-1A) is needed to connect the armament subsystem XM27E1 to the receptacle on the aircraft. For the extension cable assembly, reference TM 55-1520-228-20.

\*\*\*\*\*

g. Install the door \*\*\* door (para a (4) above). When the armament subsystem XM27E1 is mounted on the OH-58A helicopter, the door filler assembly is

replaced by the seal (fig. 2-1A in functional group 30 armament parts as referenced in TM 55-1520-228-20.

**2-3. Installation/Removal of Reflex Sight (fig. 2-2)**

\*\*\*\*\*

c. Install the control \*\*\* will be affected. When the armament subsystem XM27E1 is mounted on the OH-58A helicopter, the control rod assembly is replaced by a control rod assembly (fig. 2-1A) that belongs to functional group- 3 armament parts as referenced in TM 55-1520-22820.

**Note. When installing reflex sight XM70E1 on the OH-6A or OH-58A helicopter, check to be sure the adapter, located between the beamsplitter and beamsplitter arm, is turned correctly for the helicopter on which it is being mounted.**

\*\*\*\*\*

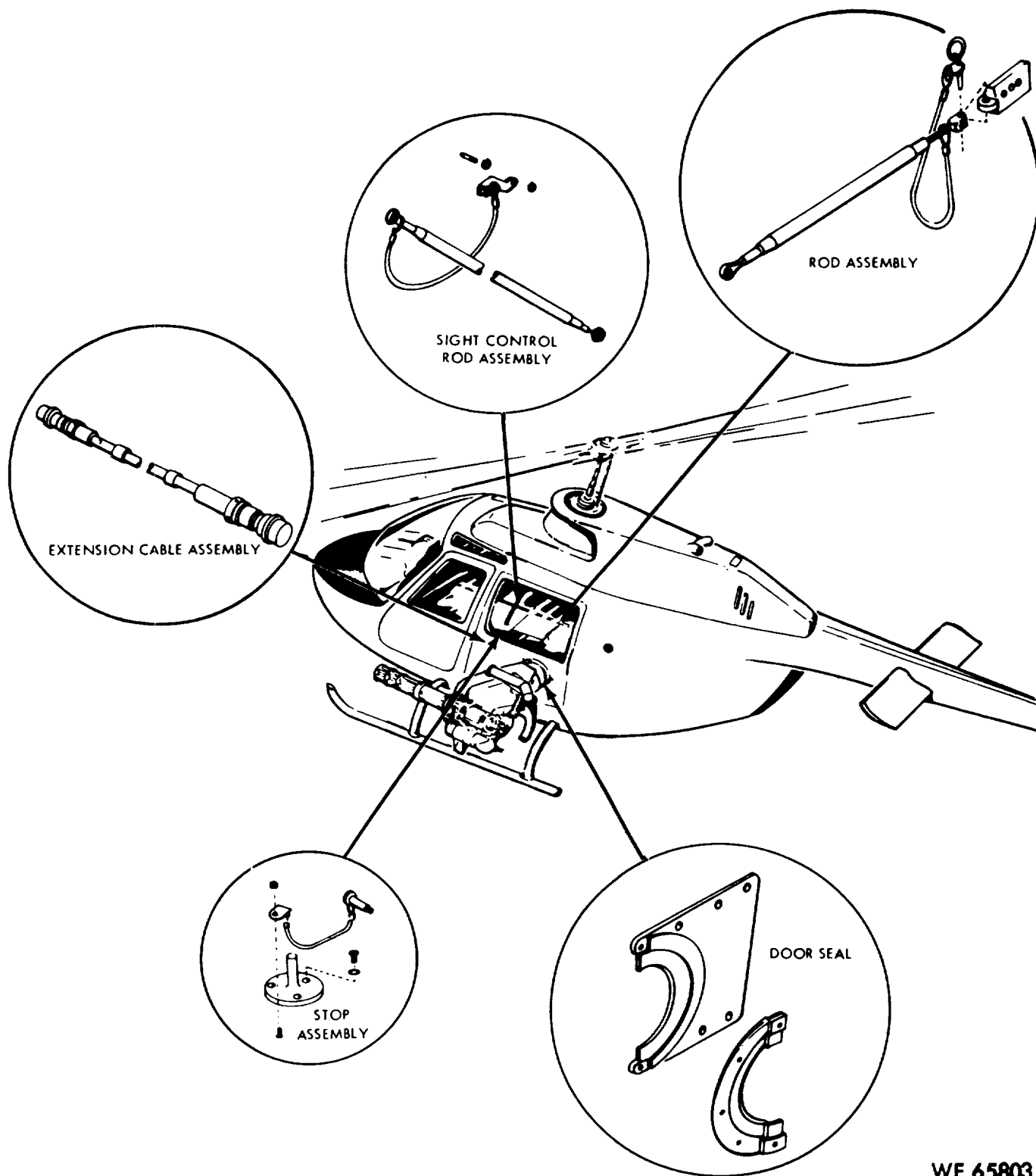

WE 65803

Figure 2-1A. (Added) Functional group 30 armament parts.

**Page 2-3:**

**2-4. Preparation for Installation/Removal of Gun Assembly (Rescinded)**

**2-6. (Superseded) Installation/Removal of Ram Air Duct Assembly (fig. 2-4)**

The following outlines installation of the ram air duct assembly; removal is accomplished in the reverse order.

- a. Insert ram air duct assembly into the link ejection chute and attach by latching the three (each) turnlock fasteners.
- b. Loop the retaining cable twice around rear support on one side and attach snap fastener in hole. Then loop the remaining end of retaining cable once around rear support on the other side and attach snap fastener in remaining hole.

**Page 2-5:**

Delete figure 2-3, WE 61298 and WE 61296, and substitute figure 2-3, WE 66378, Assembly of gun assembly for installation.

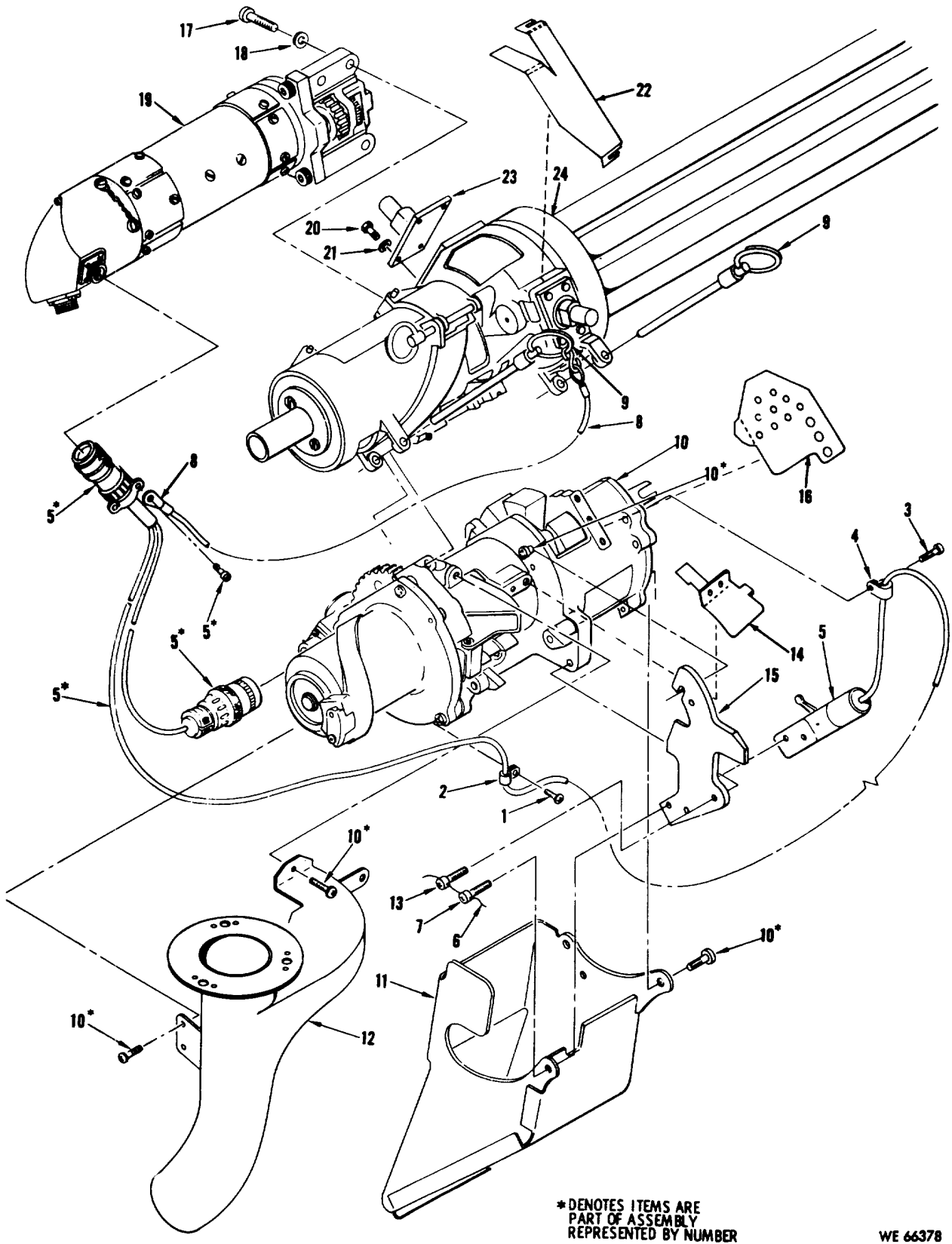
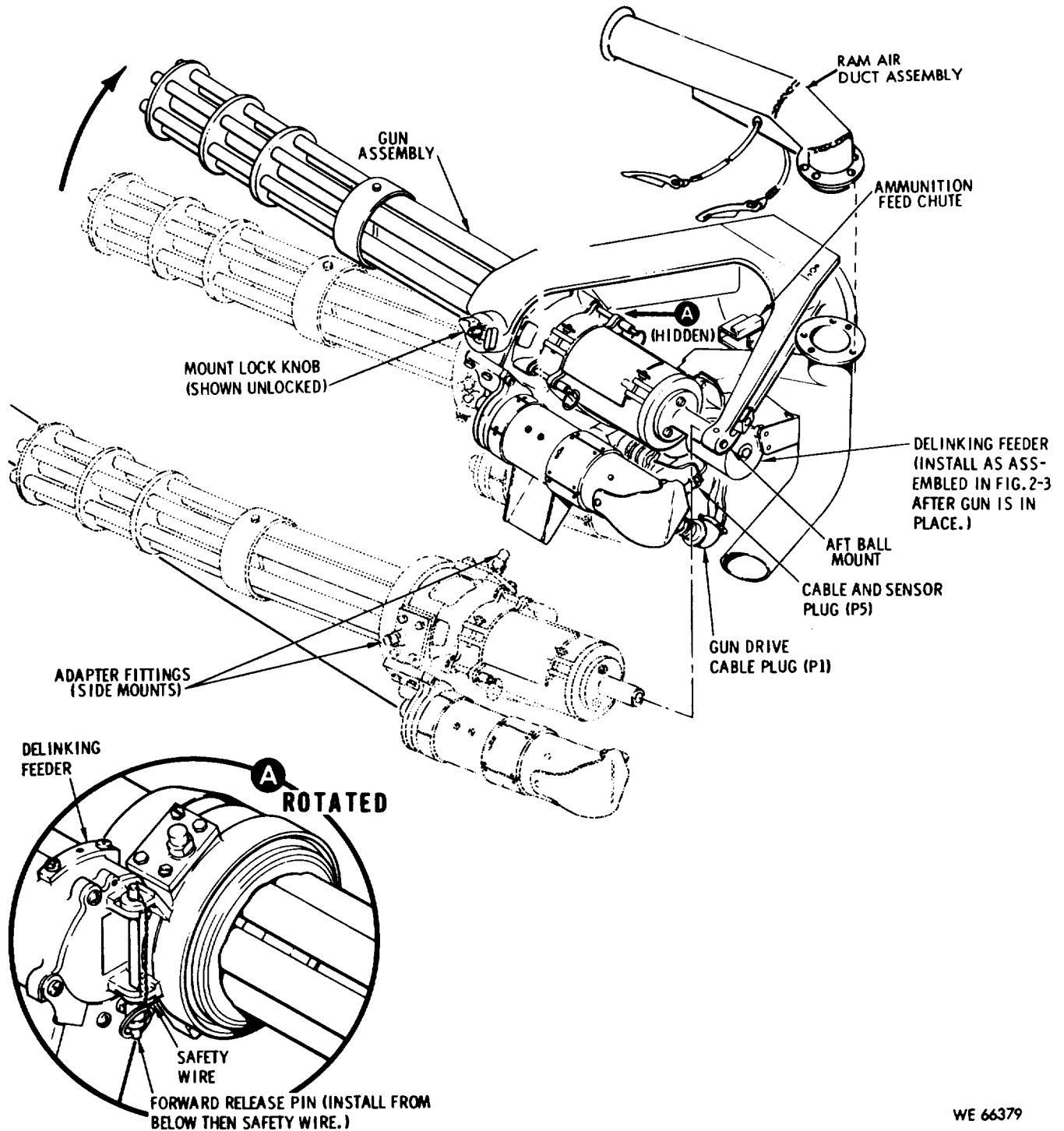

Figure 2-3. (Superseded) Assembly of gun assembly for installation.

Delete figure 2-4, WE 15629A, and substitute

figure 2-4, WE 66379, Installation/Removal of gun assembly and ram air duct assembly.



WE 66379

Figure 2-4. (Superseded) Installation/Removal of gun assembly and ram air duct assembly.

Table 2-2. Control and Indicators

Control or Instrument	Function	Ref.
<p style="text-align: center;">* *</p> <p>SYSTEM MODE MASTER switch</p> <p style="text-align: center;">* *</p>	<p style="text-align: center;">* * * *</p> <p>Provides mode selection *** trigger is depressed.</p> <p style="text-align: center;">* * * *</p> <p style="text-align: center;">* * * *</p> <p><b><u>Warning: Firing should be accomplished in short bursts as controlled by the three-second burst limiter. If combat emergency requires expending a full compliment of ammunition (2,000 rounds) by continued recycling of the burst limiter, a minimum of 15 minutes cooling time must be observed before starting to fire the next compliment. Failure to comply with the above procedure will result in possible barrel failure and a definite reduction in barrel life</u></b></p>	<p style="text-align: center;">*</p> <p>Fig. 1-16</p> <p style="text-align: center;">*</p>

**2-10. Operational Check--Power Off**

- a. Remove fairing assembly (para 2-6). (Rescinded)
- c. Install fairing assembly (para 2-6). (Rescinded)

\* \* \* \* \*

**2-13. Boresighting--Distant Aiming Point Method**

\* \* \* \* \*

- b. (Superseded) Time gun by depressing timing pin (fig. 2-5); install the adapter (with streamer attached) and boresight (fig. 2-6) in the topmost gun barrel (12 o'clock position).

**2-16. Loading Instructions**

\* \* \* \* \*

- c. Remove fairing assembly from mount assembly as shown in figure 2-4. (Rescinded)

\* \* \* \* \*

- g. (Superseded) Install safing sector and housing cover on gun. Close and latch ammunition container assembly cover.

**2-17. (Superseded) Unloading and Cleaning Instructions**

- a. Prior to unloading and clearing the gun, check to make sure the following conditions exist:

- (1) Helicopter BATT-OFF-EXT switch: OFF
- (2) SYSTEM MODE MASTER switch: OFF
- (3) ARMED/SAFE switch: SAFE
- (4) Warning lights out

**Warning: A firing pin may be cocked and ready to be released. Before removing safing sector and housing cover, rotate barrels clockwise (opposite firing direction) slightly to prevent firing. Failure to adhere to these instructions explicitly can result in discharge of the weapon.**

- b. Install bullet trap assembly (fig. 2-8A) on barrel cluster as follows:

- (1) Adjust quick release pins for tight fit in bullet trap housing as follows:

- (a) Loosen set screw.
- (b) Insert pin assembly into hole in housing and adjust inner pin until expanding segments fit tightly in hole.
- (c) Tighten set screw.

- (2) Insert bullet trap assembly on barrel cluster until barrels contact deflector in housing of bullet trap assembly.

- (3) Rotate bullet trap assembly in the direction opposite that of gun firing rotation (standing at rear of machine gun M134, firing rotation is in a counterclockwise direction) until barrels seat within recessed area of the deflector in the bullet trap assembly.

(4) Install quick release pins of the bullet trap harness assembly into any two holes directly opposite (180°) of each other giving the least end play of the bullet trap housing, making sure that the quick release pins are placed behind the third rib of the machine gun M134 barrel clamp assembly.

(5) Removal of bullet trap assembly is in reverse order of installation.

**Warning: Clear all personnel and equipment from firing area. Extreme care must be exercised to ensure that personnel do not walk or stand in front of or rotate the barrels of an uncleared weapon when installing the bullet trap.**

c. Remove safing sector and housing cover from the machine gun M134 (fig. 3-5).

d. Release ammunition chute from delinking feeder and remove one cartridge from the linked cartridges.

e. Manually rotate barrels counterclockwise, viewed from breech end (firing direction), until remaining cartridges are cleared from delinking feeder and the machine gun M134.

f. Open cover on ammunition container assembly and pull linked ammunition from chutes and into ammunition container assembly. Remove ammunition container assembly if required.

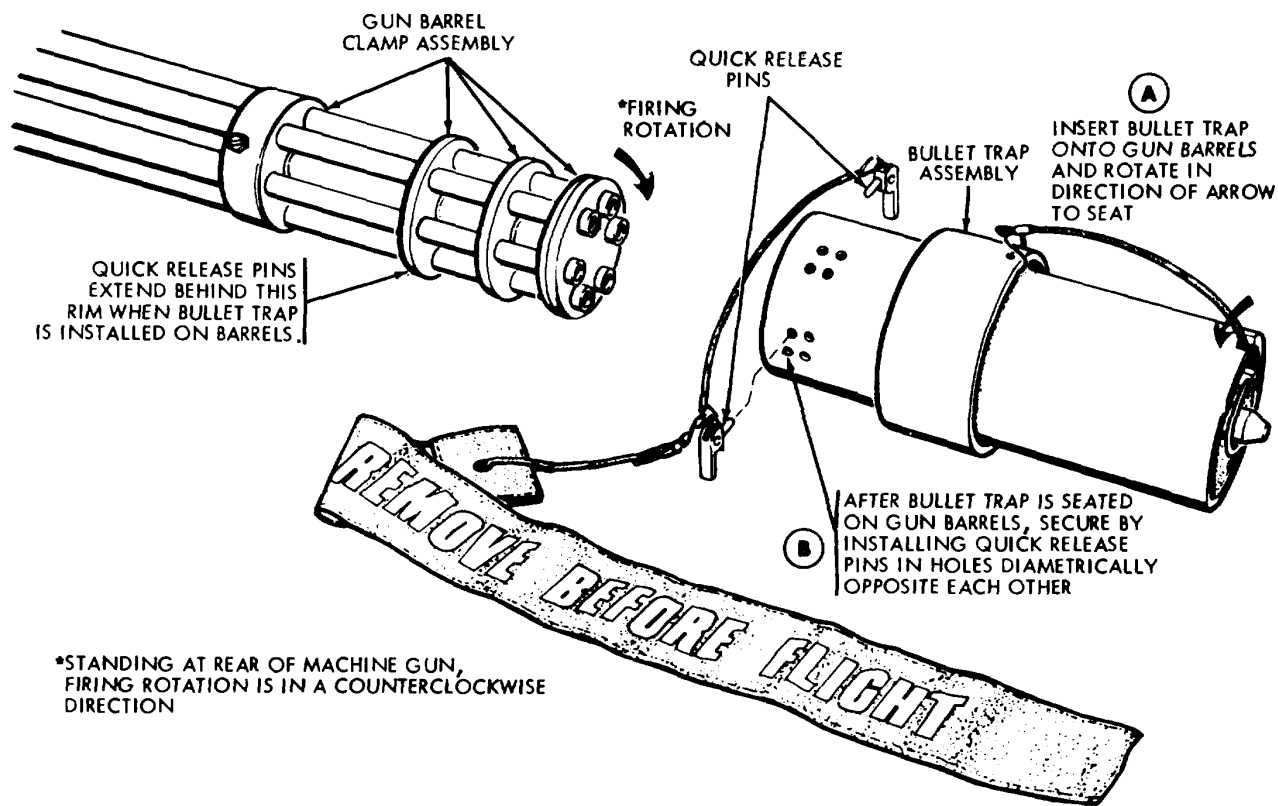

Figure 2-8A. (Added) Installation of bullet trap assembly.

Page 3-4:

Table 3-2. Special Tools and Equipment

Item	Identifying No.	Reference		Name and use
		Figure	Paragraph	
*	*	*	*	* * *
4	4933-254-6346	2-8A		Bullet trap assembly to prevent injury from accidentally fired bullet(s).

**3-9. (Superseded) Disassembly/Assembly (fig. 2-3)**

The following procedure outlines installation of assemblies and making up the gun assembly. Removal is accomplished in the reverse order.

a. Install the following on the gun (24, fig. 2-3):

- (1) Install the gun mounting adapters (23) and gun housing shield (22) with bolts (20) and washers (21).
- (2) Install gun electric drive assembly (19) with bolts (17) and washers (18).

b. Install the following on the delinking feeder (10).

- (1) Remove existing nose guide 11686381 and install replacement nose guide 11697451 (15) with screw (13).
- (2) Attach cartridge ejection chute (11) with three existing screws (10\*) at forward end of the delinking feeder.
- (3) Install sensing unit and cable assembly (5) on nose guide (15) with two screws (7).

**Note. The lower screw (7) extends through the aft attaching point for cartridge ejection chute (11).**

- (4) Lockwire (6) the screws (7 and 13).
- (5) Secure the cable of the sensing unit and cable assembly (5) with clamp (4) and screw (3) and with clamp (2) and screw (1).
- (6) Secure feeder sprocket shield (16) with two screws (10\*).
- (7) Secure feeder shield (14) with one screw (10\*).
- (8) Connect electrical plug (P6) (5\*) to the gun feed solenoid on the delinking feeder (10).
- (9) Attach lanyard (8) to electrical plug (P5) (5\*) opposite ground wire, with existing connector screw (5\*) and nut. Attach aft delinking feeder release pin (9) to lanyard (8).

**Note. The lanyard prevents damage to the sensing unit by preventing removal of the delinking feeder prior to the removal of electrical connector (P5) from the gun electric drive assembly. Make certain that the lanyard is properly installed.**

- (10) Attach link ejection chute (12) with two existing screws (10\*) in link guide and two screws (10\*) in feeder cam housing of the delinking feeder (10).

**Page 3-20:**

Delete figure 3-13, WE 15695A, and substitute figure 3-13, WE 19653A, Bolt assembly--exploded view.

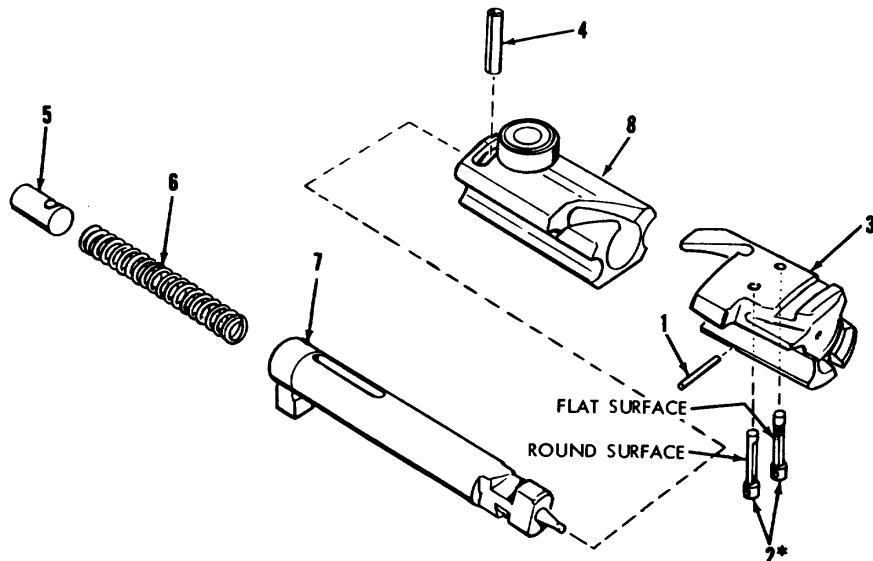

\* NOTE: LOCKING PINS (2) ROUND SURFACE MUST BE FACING OUTSIDE SURFACE OF BOLT HEAD, AND CENTER FLAT SURFACE TOWARD FIRING PIN (7).

WE 19653A

**Figure 3-13. (Superseded) Bolt assembly--exploded view.**



### Section X. (Superseded) MAINTENANCE OF RAM AIR DUCT ASSEMBLY

#### 3-17. Removal/Installation

Refer to paragraph 2-6.

#### 3-18. Cleaning, Inspection, and Repair

- a. *Cleaning.* None required.
- b. *Inspection.* Inspect for frayed cable, tears, and missing fasteners. Inspect ram air duct for obstructions.
- c. *Repair.* Repairs are limited to replacement of parts available at organizational level. Refer to TM 9-1005-298-20P.

a. *Beamsplitter.* The beamsplitter is replaced by loosening the single attaching screw at the end of the arm. A spare beamsplitter is included in the sight carrying case.

b. *Adapter.* The adapter is located between the beamsplitter and the arm. The adapter is replaced by loosening the single attaching screw at the end of the arm and removing the beamsplitter.

c. *Lamp.* The projector lamp is replaced by loosening three captive screws attaching the upper housing to the projector. Hold housing aside while replacing the bulb. Reinstall upper housing.

#### 3-24. (Superseded) Disassembly / Assembly (fig. 3-22)

Complete disassembly is not authorized at organizational level maintenance. Disassembly and assembly at organizational level is primarily for replacement of the following components, when defective.

**Note.** The frosted side of the bulb is to face the projector reticle.

Delete figure 3-22, WE 15627A, and substitute figure 3-22, WE 66381, Reflex sight XM70E1 partially exploded view.

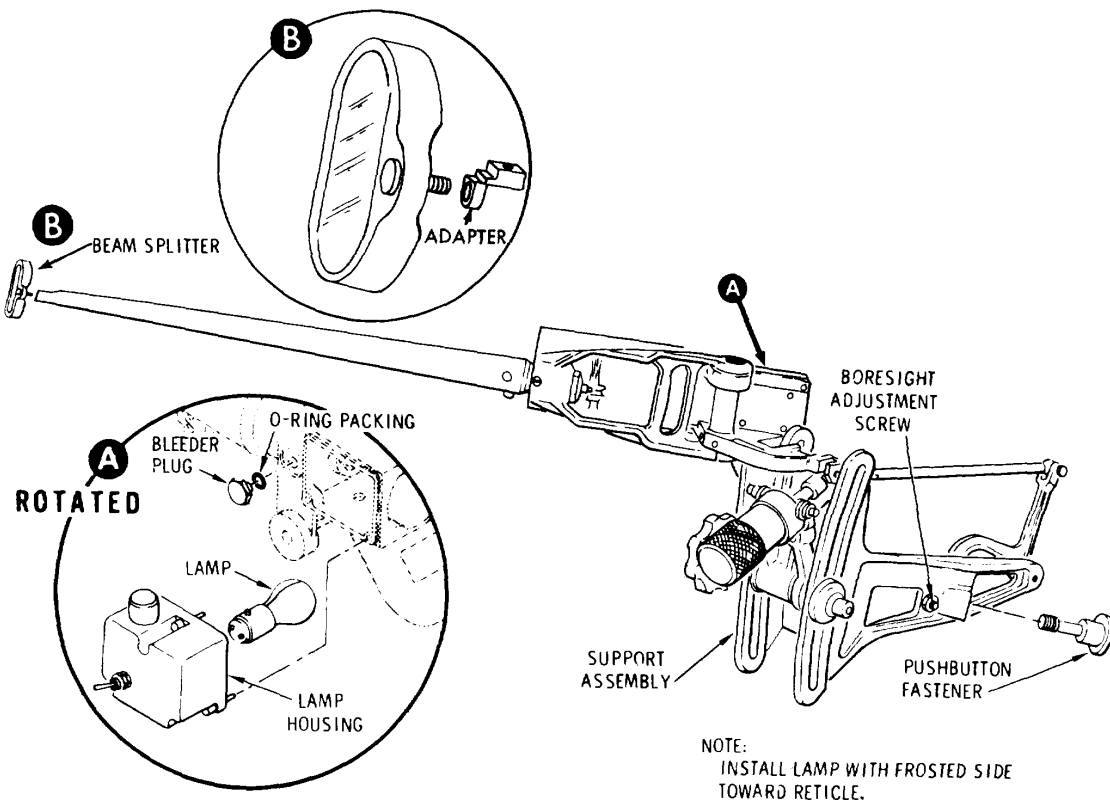

Figure 3-22. (Superseded) Reflex sight XM70E1-partially exploded view.

### 3-26. Purging of Projector Assembly (fig. 3-23)

**Note.** The item numbers referenced throughout the following paragraphs are contained in table 3-2.

#### a. Setup.

(1) (Superseded) Obtain a tank of dry technical nitrogen (item 2) and remove the threaded protective cover from outlet of the tank. Open valve momentarily to rid valve seat of any foreign matter.

### Section XIII. (Added) MAINTENANCE OF BULLET TRAP ASSEMBLY

#### 3-27. Removal/Installation of Bullet Trap Assembly

Refer to paragraph 2-17.

#### 3-28. Disassembly/Assembly

Disassembly the bullet trap assembly in accordance with figure 3-24. Assembly is in reverse order of disassembly.

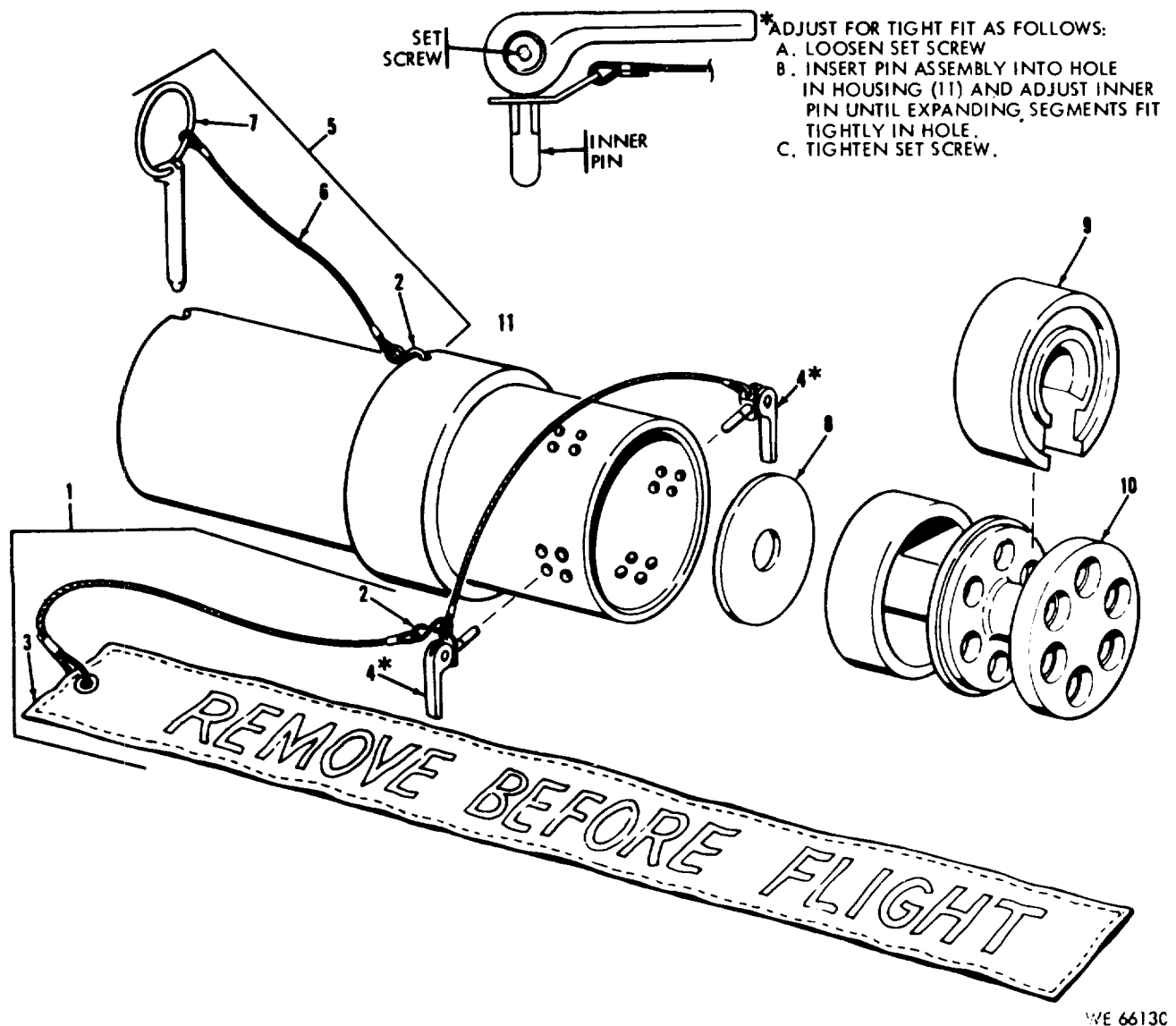

Figure 3-24. (Added) Bullet trap assembly-view.

1 -- Harness assembly  
2 -- S hook  
3 -- Streamer  
4 -- Pin assembly

5 -- Lock pin assembly  
6 -- Cable  
7 -- Pin  
8 -- Pad

9 -- Insert  
10 -- Deflector  
11 -- Housing

**Page B-2:**

(FSN) or part number (PN) if unauthorized, and illustration reference.

**4. Special Information**

\*\*\*\*\*

(2) (Superseded) *Components of major combination.* The items listed below are issued as components of the major combination. Replacement items will be requisitioned separately under their individual stock numbers. When the major combination is turned in, all components will be turned in. The items are listed with quantity incorporated in the major combination, nomenclature, Federal stock number

Gun Assembly, PN 11697410 (fig. 1-1) Ram Air Duct Assembly, PN 11697793 (fig. 1-1)

Mount Assembly, PN 11697405 (fig. 1-1) Sight Assembly, Reflex XM70E1, w/carrying case FSN 1270-832-5895 (fig. 1-1)

Decal, PN 11697403 (fig. 1-1)

**Page C-3:**

**Section II. MAINTENANCE ASSIGNMENT**

Group number 9 Fairing Assembly (Rescinded)

Group number 9 (Added) Ram Air Duct Assembly

**By Order of the Secretary of the Army:**

Official:

KENNETH G. WICKHAM,  
*Major General, United States Army,  
The Adjutant General*

W. C. WESTMORELAND,  
*General, United States Army,  
Chief of Staff.*

Distribution:

To be distributed in accordance with DA Form 12-31 (qty rqr Block No. 128), Organizational maintenance requirements for Armament Subsystem XM27E1.

Change  
No. 2



HEADQUARTERS,  
DEPARTMENT OF THE ARMY,  
Washington, D. C., 21 September 1971

**Operator and Organizational Maintenance Manual  
ARMAMENT SUBSYSTEM, HELICOPTER,  
7.62 MILUMETER MACHINE GUN: HIGH RATE, XM27E1  
(1005-9334-6242)  
(USED ON OH-6A AND OH-58A HELICOPTERS)**

TM 9-1005-298-12, 7 August 1969, is changed as follows:

Page 3-20. Paragraph 3-13 is superseded as follows:

**3-13. Disassembly/Assembly (fig. 3-14).**

*a. Disassembly.* The order of disassembly is in accordance with index number sequence of figure 3-14 and the following specific instructions.

(1) Drive out pin (10) while plate (12) remains installed to support shaft.

(2) If pin (15) is badly bent and difficult to remove, the following method may be used for removal.

(a) Place shaft-stripper-guide-gear unit on a wooden block(s) so that gear rest on block and there is clearance for shaft

(b) Strike shaft sharply with soft-faced hammer to shear pin (15).

(c) Drive out pieces of pin (15) from gear, guide, and shaft.

*b. Assembly.* Assembly is in reverse order of numerical sequence in figure 3-14 and the following specific instructions.

(1) Use 3/16 inch punch and aline holes in gear, guide, and shaft so that slot in guide is opposite point where punch enters gear.

(2) Hold gear-guide-shaft unit firmly, remove punch and install pin (15) through unit. Pin shall not protrude into slot of guide nor restrict gear tooth action.

**NOTE**

**When pin (14) is installed through stripper and shaft, the slot of stripper in line with hole for pin shall be in line with slot (para b(1)) in guide having hole for pin (15).**

(3) Install pin (14) with pin entering from slot alined in hole stripper. Pin shall be flush with surface of stripper.

(4) Slide sprocket (13) onto shaft so that alinement pin of stripper engages recess in sprocket sleeve and install plate (12), with four screws (11).

(5) Install pin (10) so that pin is flush with surface of sprocket sleeve.

Page 3-21. The illustration and key for figure 3-14 are superseded as follows:

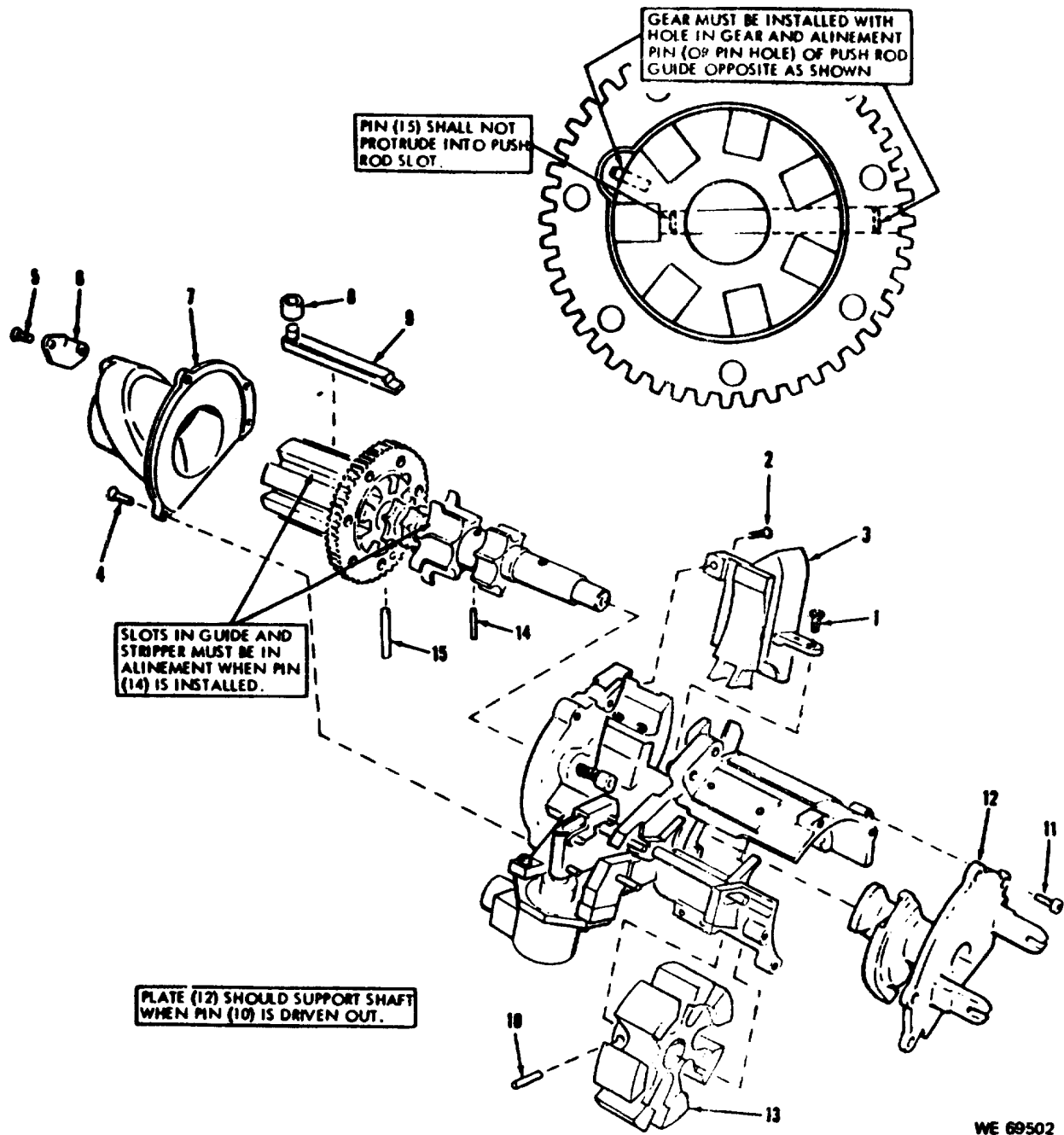

WE 69502

- |                          |                         |
|--------------------------|-------------------------|
| 1 Screw MS51958-63       | 9 Rod assembly 11701126 |
| 2 Screw 11701219         | 10 Pin 8447845          |
| 3 Link guide 11686380    | 11 Screw MS51958-63     |
| 4 Screw MS51967-44       | 12 Plate 11701133       |
| 5 Feeder insert 11701129 | 13 Sprocket 11701130    |
| 6 Screw MS51958-63       | 14 Pin 8447845          |
| 7 Cam housing 11701139   | 15 Pin MS16562-41       |
| 8 Roller 11701122        |                         |

Figure 3-14. Delinking feeder MAU-56/A – partially exploded view.

**By Order of the Secretary of the Army:**

W. C. WESTMORELAND  
*General, United States Army,  
Chief of Staff.*

Official:

VERNE L. BOWERS,  
*Major General, United States Army,  
The Adjutant General.*

Distribution:

To be distributed in accordance with DA Form 12-31 (qty rqr block nr 128) Organizational Maintenance requirements for 7.62 MM Machine Gun Armament Subsystem XM27E1.

**Changes In Force: 1, 2 and 3**

**TM 9-1005-298-12**  
**C 3**

Change }  
No. 3 }

HEADQUARTERS,  
DEPARTMENT OF THE ARMY  
Washington, D.C., 23 March 1973

**OPERATOR AND ORGANIZATIONAL MAINTENANCE MANUAL**

**ARMAMENT SUBSYSTEM, HELICOPTER,  
7.62 MILLIMETER MACHINE GUN:  
HIGH RATE, M27  
(1005-933-6242)  
(USED ON OH-6A AND OH-58A HELICOPTERS)**

---

TM 9-1005-298-12, 7 August 1969, is changed as follows:

Change the title to read as above.

Change weapon designator XM27E1 to read M27 wherever it may appear throughout the manual.



**APPENDIX B (Superseded)**  
**BASIC ISSUE ITEMS LIST AND ITEMS**  
**TROOP INSTALLED OR AUTHORIZED LIST**

---

**Section I. INTRODUCTION**

**B-1. Scope.**

This appendix lists basic issue items and items troop installed or authorized required by the crew/operator for operation and required for performance of organizational maintenance of Armament Subsystem M27.

**B-2. General**

This Basic Issue Items, Items Troop Installed or Authorized List is divided into the following sections:

*a. Basic Issue Items List-Section II.* A list, in alphabetical sequence, of items which are furnished with, and which must be turned in with the end item.

*b. Items Troop Installed or Authorized List Section III.* A list of items in alphabetical sequence, which at the discretion of the unit commander, may accompany the end item, but are not subject to be turned in with the end item.

**B-3. Explanation of Columns.**

The following provides an explanation of columns found in the tabular listings.

*a. Federal Stock Number.* Indicates the Federal stock number assigned to the item and will be used for requisitioning purposes.

*b. Description.* Indicates the Federal item name and a minimum description required to identify the item. The last line indicates the reference number followed by the applicable Federal supply code for manufacturer (FSCM) in parenthesis. The FSCM is used as an element in item identification to designate manufacturer or distributor or Government agency, etc., and is identified in SB 708-42. Items that are included in kits and sets are listed below the name of the kit or set with

quantity of each item in the kit or set indicated in front of the item name.

*c. Unit of Measure (U/M).* Indicates the standard or basic quantity by which the listed item is used in performing the actual maintenance function. This measure is expressed by a two-character alphabetical abbreviation, e.g., ea, in., pr, etc., and is the basis used to indicate quantities and allowances in subsequent columns. When the unit of measure differs from the unit of issue, the lowest unit of issue that will satisfy the required units of measure will be requisitioned.

*d. Quantity Furnished with Equipment (Basic Issue Items Only).* Indicates the quantity of the item furnished with the equipment.

*e. Quantity Authorized (Items Troop Installed or Authorized Only).* Indicates the quantity of the item authorized to be used with the equipment.

**B-4. Special Information.**

*a.* Action change codes indicated in the left-hand margin of Sections II and III denote the following:

N--indicates an added item.  
C--indicates a change in data.  
R--indicates a change in FSN only.

*b.* The following publications pertain to armament subsystem M27 and its components:

LO 9-1005-298-12, Lubrication Order  
TM 9-1005-298-20P, Organizational  
Maintenance Repair Parts and Special Tools List  
TM 9-1005-298-34, Direct Support and General  
Support Maintenance Manual  
TM 9-1005-298-34P, Direct Support and  
General Support Maintenance Repair Parts and Special  
Tools List.

**Section II. BASIC ISSUE ITEMS LIST**

**Not Applicable**

**Section III. ITEMS TROOP INSTALLED OR AUTHORIZED LIST**

(1) Federal stock number	(2) Description  Reference number & mfr. <span style="float:right">Code Usable on code</span>	(3) Unit of meas	(4) Qty auth
1005-556-4174	BRUSH, CLEANING, SMALL ARMS: BORE 5564174 (19204)	EA	1
1005-690-3115	BRUSH, CLEANING, SMALL ARMS: CHAMBER 7790452 (19204)	EA	1
1005-650-4508	BRUSH, CLEANING, SMALL ARMS: ROTOR 7790342 (19204)	EA	1
1005-694-1662	BUFFER: MUZZLE PROTECTOR 7268275 (19204)	EA	1
1005-933-6240	CONTAINER, AMMUNITION 1169770 (02731)	EA	1
1005-793-6761	HANDLE ASSEMBLY: CLEANING ROD 7266115 (19204)	EA	1
1005-726-6109	RODS, CLEANING, SMALL ARMS 7266109 (19204)	EA	5
1005-726-6110	SWAB HOLDER SECTION: SMALL ARMS 7266110 (19204)	EA	1

## Appendix C MAINTENANCE ALLOCATION CHART

---

### Section I. INTRODUCTION

#### C-1. General.

The Maintenance Allocation Chart identifies the maintenance operations that must be performed for each component and assembly of the end item. Each maintenance operation is assigned to the lowest category of maintenance able to perform the task in terms of available time, tools, test and support equipment, skills, and employment of the end item.

#### C-2. Maintenance Functions.

Maintenance functions are limited to and defined as follows:

*a. Adjust.* Maintain within prescribed limits by bringing into proper or exact position, or by setting the operating characteristics to the specified parameters.

*b. Align.* To adjust specified variable elements of an item to bring about optimum or desired performance.

*c. Calibrate.* To determine and cause corrections to be made on or to be adjusted on instruments or test, measuring, and diagnostic equipment used in precision measurement. Consists of comparisons of two instruments, one of which is a certified standard of known accuracy to detect and adjust any discrepancy in the accuracy of the instrument being compared.

*d. Inspect.* To determine the serviceability of an item by comparing its physical, mechanical, and/or electrical characteristics with established standards through examination.

*e. Install.* The act of emplacing, seating, or fixing into position an item, part, module (component or assembly) in a manner to allow the proper functioning of the equipment/system.

*f. Overhaul.* That maintenance effort (service/action) necessary to restore an item to a completely serviceable/operational condition as prescribed by maintenance standards (e.g., DMWR) in pertinent technical publications. Overhaul does not normally return an item to like-new condition.

*g. Rebuild.* Consists of those services/actions necessary for the restoration of unserviceable equipment to like-new condition in accordance with original manufacturing standards. Rebuild is the highest degree of materiel maintenance applied to Army equipment. The rebuild operation includes the act of returning to zero those age measurements (hours, miles, etc) considered in classifying Army equipment/components.

*h. Repair.* The application of maintenance services (inspect, test, service, adjust, align, calibrate, replace) or other maintenance actions (welding, grinding, straightening, facing, remachining, or resurfacing) to restore serviceability to an item by correcting specific damage, fault, malfunction, or failure in a part, subassembly, module/component/assembly, end item, or system.

*i. Replace.* The act of substituting a serviceable like-type part, subassembly, module (component or assembly) in a manner to allow the proper functioning of an equipment/system.

*j. Service.* Operations required periodically to keep an item in proper operating condition, i.e., to clean, preserve, drain, paint or to replenish fuel/lubricants/hydraulic fluids or compressed air supplies.

*k. Test.* To verify serviceability and to detect incipient failure by measuring the mechanical or electrical characteristics of an item and comparing those characteristics with prescribed standards.

*l. Symbols.* The assignment of each item's maintenance operation to the lowest level of maintenance is recorded in the appropriate column by the maintenance level symbol "C" for operator/crew, "O" for organizational, "F" for direct support, "H" for general support, and "D" for depot maintenance.

#### C-3. Explanation of Format.

Section II, the Maintenance Allocation Chart (MAC), contains the following data elements.

*a. Column a. Group Number.* Column 1 lists group numbers, the purpose of which is to match components, assemblies, subassemblies, and modules with the next higher assembly.

*b. Column b. Functional Group.* Column 2 lists the next higher assembly group and the item names of components, assemblies, subassemblies, and modules within the group for which maintenance is authorized.

*c. Column c. Maintenance Function.* Column 3 lists the eleven maintenance functions defined in C-2 above. Each maintenance function required for an item is specified by the symbol among those listed in C-2 above which indicates the level responsible for

the required maintenance. Under the symbol is listed an appropriate work measurement time value.

*d. Work Measurement Time.* This is the active repair time required to perform the maintenance function, included directly below the symbol identifying the category of maintenance. The figures have been developed under conditions (real or simulated) corresponding to those that are considered normal for TOE units operating in the field. The skill levels used to obtain the measurement times approximate those found in typical TOE units. Active repair time is the average aggregate time required to restore an item (subassembly, assembly, component, module, end item or system) to a serviceable condition under typical field operating conditions. This time includes preparation time, fault isolation/diagnostic time and QA/QC time in

addition to the time required to perform specific maintenance functions identified for the tasks authorized in the maintenance allocation chart. Time is expressed in man-hours and tenths of man-hours.

*e. Column d. Tools and Equipment.* This column is used to specify, by code, those tools and test equipment required to perform the designated function. A table, suitably coded and explained, lists the tools, test, and support equipment required by the level to perform the maintenance functions and is included as a supplement to the maintenance allocation chart.

*f. Column e. Remarks.* Self-explanatory.

**SECTION II – MAINTENANCE ASSIGNMENT**

GROUP #	COMPONENT ASSEMBLY NOMENCLATURE	MAINTENANCE FUNCTION c										TOOLS AND EQUIPMENT	REMARKS	
		INSPECT	TEST	SERVICE	ADJUST	ALIGN	CALIBRATE	INSTALL	REPLACE	REPAIR	OVERHAUL			REBUILD
a	b											d	e	
1	Armament Subsystem, Helicopter, 7.62 milli-meter Machine Gun: M27	0		0		0		0		0	H	D	1, 2, 3, and 4.	
2	Gun Assembly	.5		.3		.2		.2		.5	2.0	2.5	2	
3	Machine Gun, 7.62 Millimeter: M134	.2	F	.2				.1	0	.4	H		2 and 3.	
4	Bolt Assembly	0	.1	0				.1	.1	.3	1.0		2	
5	Barrel	.1	.1	0				1		.2			2	
6	Rotor Assembly	0	H	0				0		.2			2 and 3.	
7	Feeder Delinker MAU-56/A	.1	1	.1				0	0	.2			2	
8	Drive Assembly, Electric, Gun	0		0				.1	.2	.4	D		2 and 3.	
9	Sensing Unit and Cable Assembly	.1		.1				0		.4	2.0			
10	Ram Air Duct Assembly	0						.3		1.0			2	
11	Mount Assembly	.1						.1	.1	.2				
12	Container Assembly, Ammunition	0		0				0	0	0			2.	
13	Chute, Ammunition	.1		.2				.2	.2	.4			2.	
14	Control Box Assembly	0	F	0		.1		.1					2 and 3.	
15	Electric Cabling	0	F	0				0	0	F			2 and 3.	
16	Housing and Tube Assembly	.1	.2	.1				.3	.2	1.5			2, 3 and 4.	
17	Tube Assembly	0		0				.1		.3	H		2 and 3.	
18	Housing Assembly	.1		.1				.2					2, 3 and 4.	
19	Motor and Sensor Assembly	0		.1				2	F	1.0				
20	Rod Assembly, Control (Sight Drive)	.1	0	.2				F	F	F	D		2.	
21	Sight, Reflex: XM70E1	0		0				.5	.5	1.0			5, 6, 7 and 8.	
22	Support Assembly	.1		.3				.2	.2	.4	H			
23	Control Assembly, Elevation	0		.1		0		.3	.2	.4	.5			
24	Reticle Image Projector	.1		.3		.1			.4	1.0	1.5			
25	Height Adjustment Linkage	0		.2				.5	.5	1.5	2.0			
26	Main Projector Housing	.1		0		0			F	F	H			
27	Lamp Housing Assembly	0		0					.5	F	H			
		.1		.1				.5		1.0	2.0			

**TOOL TEST EQUIPMENT REQUIREMENTS**

<b>Tool or Test Equipment Ref Code</b>	<b>Maintenance Category</b>	<b>Nomenclature</b>	<b>FSN</b>	<b>Tool Number</b>
1	0	Boresight Kit:	4933-930-1957	
2	0	Tool Set, Aircraft Armament Repairman: MOS 45J Basic	4933-987-9816	
3	F	Tool Set, Aircraft Armament Repairman: MOS 45J Supplemental	4933-994-9242	
4	0	Wrench, Adjusting, Forward Bearing	5120-052-3873	
5	H	Collimating Adapter, Final Inspection	4931-936-5403	
6	H	Crossleveling and Elevation Fixture	4931-652-3553	
7	0	Kit, Adapter Assembly	4931-936-4283	
8	0	Tool Set, Purging Fire Control	4931-065-1110	

By Order of the Secretary of the Army:

CREIGHTON W. ABRAMS  
*General, United States Army*  
*Chief of Staff*

Official:

VERNE L. BOWERS  
*Major General, United States Army*  
*The Adjutant General*

Distribution:

To be distributed in accordance with DA Form 12-31 (qty rqr block No. 128) organizational maintenance requirements for Armament Subsystem M27E1.

**Changes in force C 1, C 2, C 3, and C 4**

**TM 9-1005-298-12  
C4**

CHANGE }  
No. 4 }

HEADQUARTERS  
DEPARTMENT OF THE ARMY  
WASHINGTON, DC, 17 December 1975

**Aviation Unit Maintenance Manual  
ARMAMENT SUBSYSTEM, HELICOPTER  
7.62 MILLIMETER MACHINE GUN:  
HIGH RATE, M27 E1  
(NSN 1005-00-933-6242)  
(USED ON OH-6A HELICOPTER)**

TM 9-1005-298-12, 7 August 1969, is changed as follows:

The title is changed as shown above.

*Page i.* Immediately following the title add the following:

To implement the three level maintenance concept, the following changes will be made to this manual, as applicable:

- a. Substitute the words Aviation Unit maintenance for Crew/Operator and Organizational maintenance (first level of maintenance). Also, wherever the symbol for Crew/Operator maintenance (C) is used, change to the symbol for Aviation Unit maintenance (O).
- b. Substitute the words Aviation Intermediate maintenance for Direct Support and General Support maintenance (second level of maintenance). Also, wherever the symbol for General Support maintenance (H) is used, change to the symbol for Aviation Intermediate maintenance (F).
- c. The Depot level of maintenance remains the same (third level of maintenance).
- d. Under the new three level maintenance concept, the maintenance codes are as follows: Aviation Unit Maintenance (O), Aviation Intermediate Maintenance (F), and Depot Maintenance (D).

By Order of the Secretary of the Army:

Official:

FRED C. WEYAND  
*General, United States Army  
Chief of Staff*

PAUL T. SMITH  
*Major General, United States Army  
The Adjutant General*

Distribution:

To be distributed in accordance with DA Form 12-31 (qty rqr block No. 409), Operator requirements for 7.62-MM Machine Gun, High Rate, M27.





**OPERATOR AND ORGANIZATIONAL MAINTENANCE MANUAL**

**ARMAMENT SUBSYSTEM, HELICOPTER, 7.62 MILLIMETER**

**MACHINE GUN: HIGH RATE, XM27E1 (1005-933-6242)**

**(USED ON OH-6A HELICOPTER)**

*This manual is current as of 24 February 1969*

		Paragraph	Page
CHAPTER	1. INTRODUCTION		
SECTION	I. General.....	1-1, 1-3	1-1
SECTION	II. Description and data.....	1-4,1-7	1-1, 1-10
CHAPTER	2. GROUND CREW OPERATING INSTRUCTIONS		
SECTION	I. Installation and removal of armament subsystem.....	2-1, 2-6	2-1, 2-3
SECTION	II. Controls and instruments .....	2-7, 2-8	2-8
SECTION	III. Operational checks .....	2-9, 2-11	2-9
SECTION	IV. Boresighting.....	2-12, 2-14	2-10
SECTION	V. Operational services .....	2-15, 2-17	2-13
CHAPTER	3. SERVICE AND MAINTENANCE INSTRUCTIONS		
SECTION	I. Service upon receipt of material.....	3-1, 3-2	3-1
SECTION	II. Repair parts, tools, and equipment.....	3-3, 3-4	3-4
SECTION	III. Lubrication .....	3-5	3-4
SECTION	IV. Preventive maintenance.....	3-6	3-4
SECTION	V. Troubleshooting .....	3-7	3-6
SECTION	VI. Maintenance of gun assembly.....	3-8, 3-10	3-14
SECTION	VII. Maintenance of machine gun M134.....	3-11, 3-12	3-14, 3-17
SECTION	VIII. Maintenance of delinking feeder MAU-56/A.....	3-13, 3-14	3-20
SECTION	IX. Maintenance of gun electric drive assembly.....	3-15, 3-16	3-21
SECTION	X. Maintenance of fairing assembly.....	3-17, 3-19	3-22
SECTION	XI. Maintenance of mount assembly.....	3-20, 3-22	3-24
SECTION	XII. Maintenance of helicopter reflex sight XM70E1.....	3-23, 3-26	3-31, 3-32
CHAPTER	4. AMMUNITION		
SECTION	I. General.....	4-1, 4-2	4-1
SECTION	II. Classification .....	4-3, 4-4	4-1
SECTION	III. Identification .....	4-5, 4-7	4-2
SECTION	IV. Care, handling, and preservation .....	4-8, 4-9	4-2, 4-8
CHAPTER	5. ADMINISTRATIVE STORAGE AND DESTRUCTION OF MATERIEL TO PREVENT ENEMY USE		
SECTION	I. Administrative storage .....	5-1, 5-3	5-1
SECTION	II. Destruction of materiel to prevent enemy use.....	5-4, 5-8	5-1, 5-2
APPENDIX	A. REFERENCES .....		A-1
APPENDIX	B. BASIC ISSUE ITEMS LIST .....		B-1
APPENDIX	C. MAINTENANCE ALLOCATION CHART.....		C-1
APPENDIX	D. ELECTRICAL SYMBOLS.....		D-1
INDEX	.....		I-1

## CHAPTER 1

### INTRODUCTION

#### Section I. GENERAL

##### 1-1. Scope

a. This manual contains information and instructions for operator and organizational maintenance of high rate 7.62 millimeter machine gun helicopter armament subsystem XM27E1.

b. Maintenance responsibilities will apply as reflected in the maintenance allocation chart and by allocation of repair parts and special tools.

##### 1-2. Forms and Records

a. *Authorized Forms.* DA Forms and procedures used for equipment maintenance will be only those prescribed in TM 38-750, Army Equipment Record Procedures. Refer to DA Pam 310-2 for listing of all forms.

**Note. List the serial numbers of both the housing and rotor when completing DA Form 2408-4. The true serial number of the weapon, preceded by SN, is impression stamped on rotor face (not the chamfered edge). Serial numbers on**

**earlier models were electrically penciled and may not be preceded by SN.**

b. *Recommendations for Maintenance Manual Improvements.* Report of errors, omissions, and recommendations for improving this publication by the individual user is encouraged. Reports should be submitted on DA Form 2028 (Recommended Changes to DA Publications) and forwarded direct to: Commanding General, U. S. Army Weapons Command, ATTN: AMSWE-SMM-P, Rock Island, Illinois 61201.

##### 1-3. Equipment Serviceability, Storage, and Destruction

a. *Equipment Serviceability Criteria.* Refer to TM 9-1005-298-ESC for armament subsystem serviceability criteria.

b. *Administrative Storage.* Refer to Chapter 5 of this manual for storage instructions.

c. *Destruction to Prevent Enemy Use.* Refer to Chapter 5 of this manual for instructions concerning degree of destruction, priorities, and methods.

#### Section II. DESCRIPTION AND DATA

##### 1-4. Description

The high rate 7.62 millimeter machine gun helicopter armament subsystem XM27E1 is used on the OH-6A helicopter. The gun is located on the left side of the aircraft, attached to the external portion of the mount assembly (fig. 1-1 and 1-2). See table 1-1 for a listing of main components of the subsystem.

a. *Gun Assembly.* The main components of the gun assembly (fig. 1-2) are the 7.62 millimeter machine gun M134, delinking feeder MAU-56/A, gun electric drive assembly, sensing unit and the cable assembly, ejection chutes, and two gun mounting adapters.

(1) *7.62 millimeter machine gun M134.* The components of the 7.62 millimeter machine gun M134 (fig. 1-3) are the rotor assembly, six bolt assemblies, six removable bolt tracks, gun housing assembly, rear gun support, six barrels, barrel clamp assembly, safing

sector, housing cover, and two quick release pins. As the rotor turns within the stationary housing cover, the bolt assembly rollers follow the main cam path of the housing cover, causing the bolt assemblies to move along the accommodating tracks. Each barrel is mounted in the barrel clamp assembly, in a fixed position, in alignment with a bolt assembly.

(a) *Rotor assembly and removable bolt tracks.* The rotor assembly (fig. 1-4) is supported in the gun housing by ball bearings. Six bolt tracks are spaced equally around the rotor surface. Each bolt track is composed of front and center portions, which are grooves cut into the rotor, and a removable bolt track (fig. 1-5). The removable bolt tracks are attached to ribs along the rotor and are removed for installation or removal of bolt assemblies. An S-shape triggering cam, machined into the bottom of each bolt track, cocks and releases bolt firing pins.

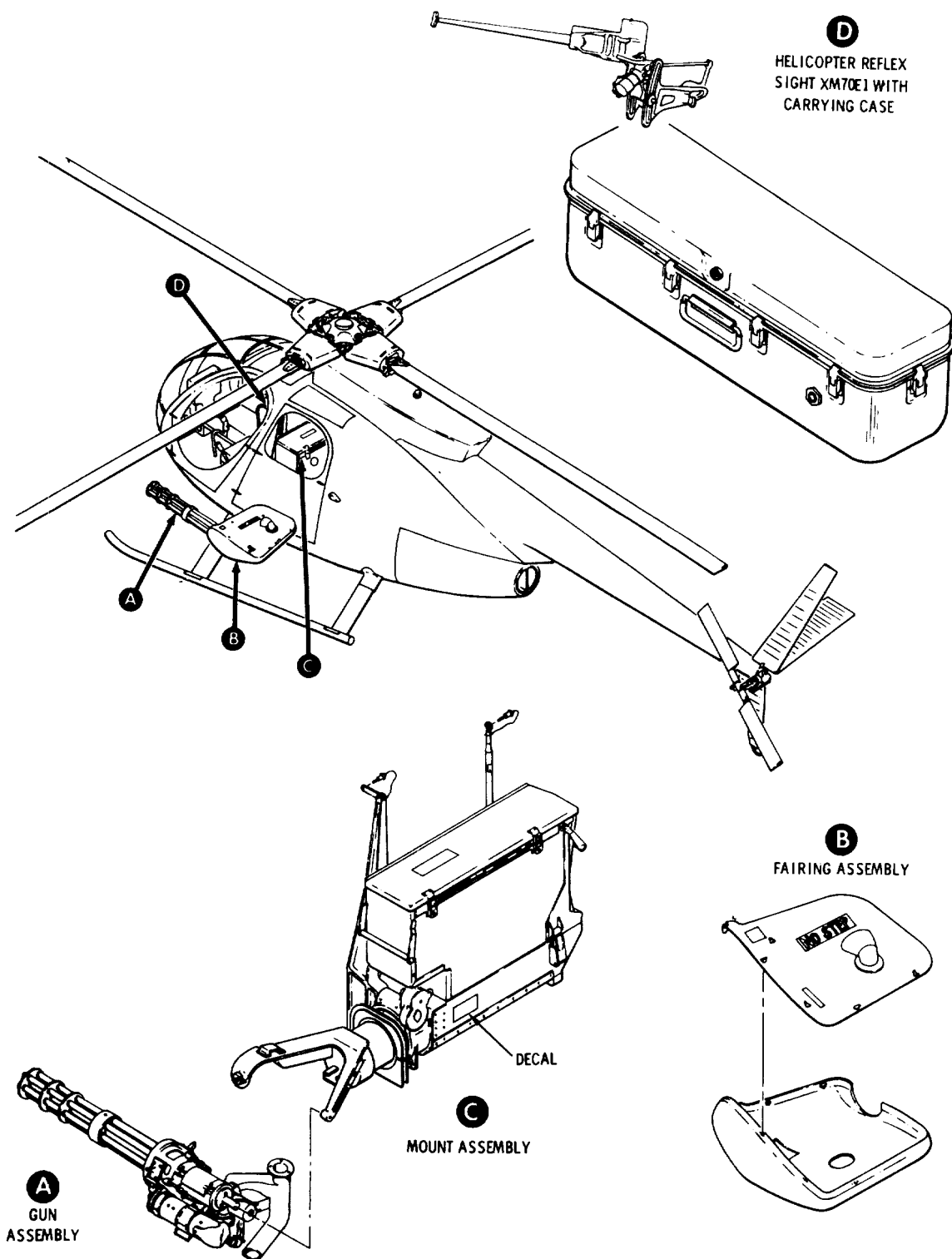

Figure 1-1. Components of armament subsystem XM27E1.

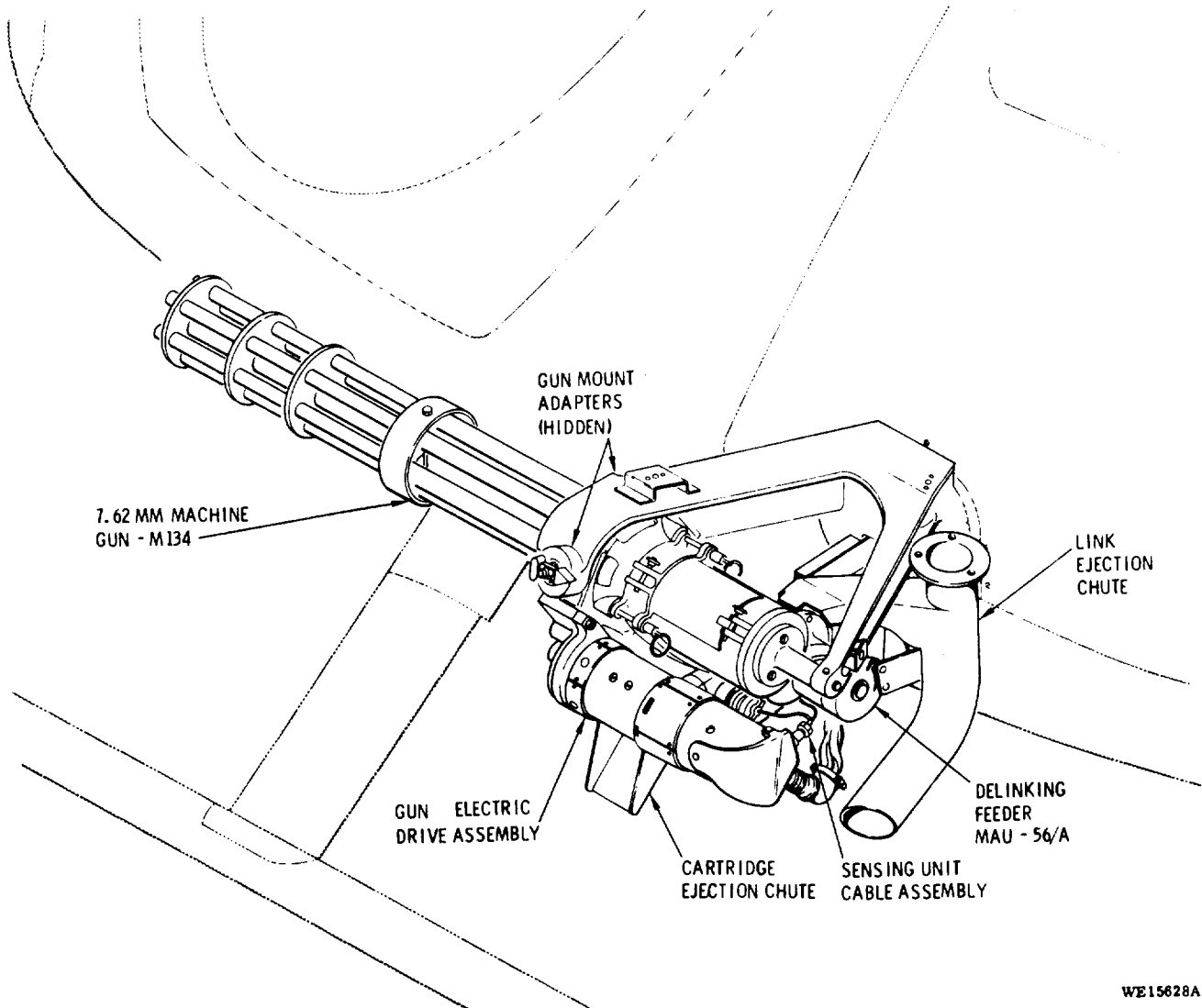

Figure 1-2. Components of gun assembly.

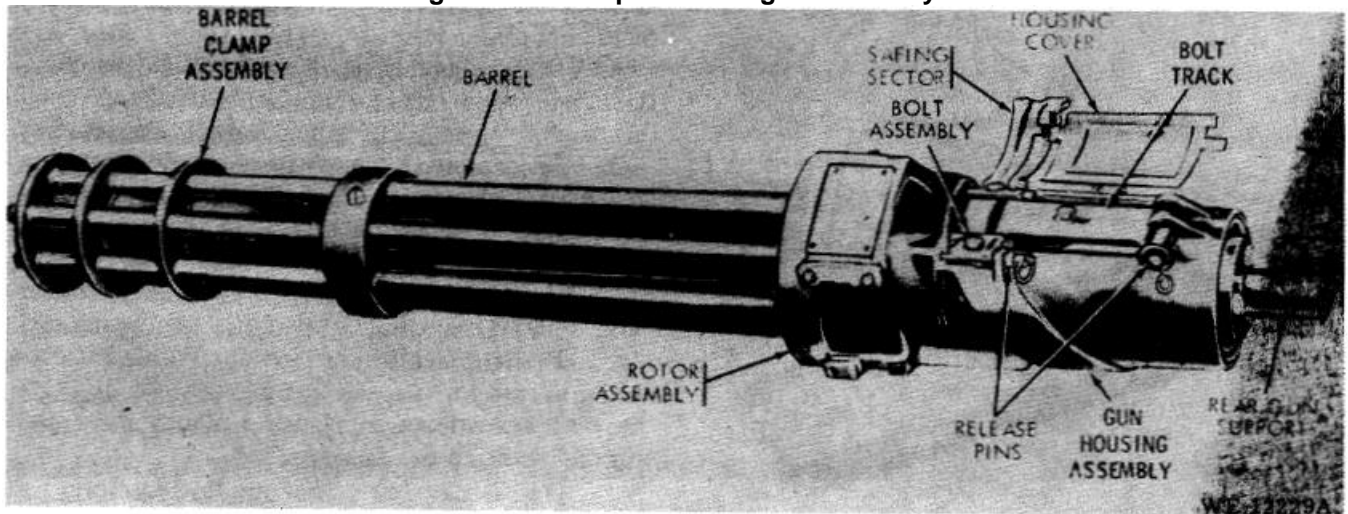
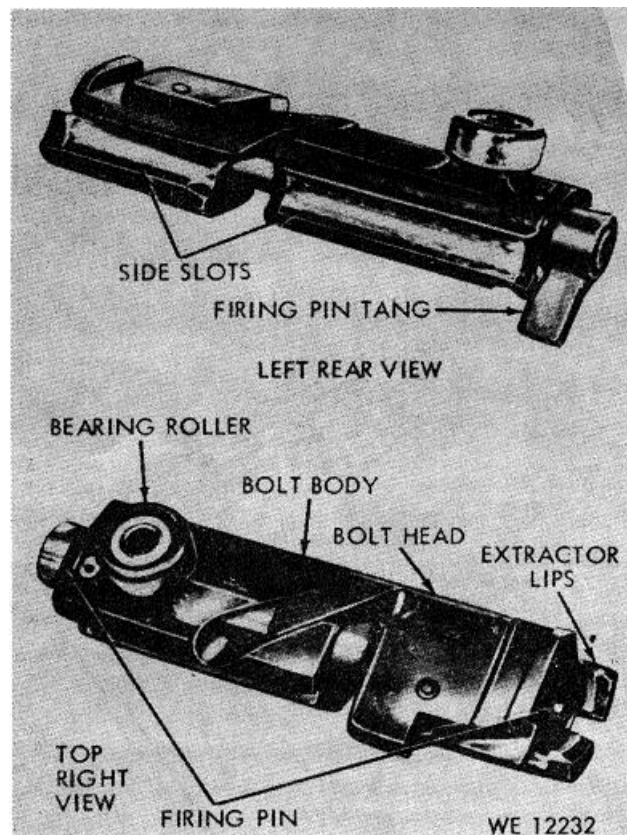

Figure 1-3. Components of 7.62 millimeter machine gun M134.

**Table 1-1. Main Components of Armament Subsystem XM27E1.**

Nomenclature	Quantity Per Subsystem	Fig. No. Reference
Gun Assembly	1	1-1
Fairing Assembly	1	1-1
Mount Assembly	1	1-1
Sight, Assembly, Reflex:	1	1-1
XM70E1, (w/carrying case)	1	1-1
Decal	1	1-1



**Figure 1-6. Bolt assembly-left rear and top right views.**

(b) *Bolt assemblies.* The bolt assemblies (fig. 1-6) are of rotary-head and fixed extractor design, with side slots engaging the bolt tracks in the rotor assembly. The angular position of the firing pin relative to the bolt head is controlled by the action between the firing pin tang and the triggering cam in the rotor. The firing pin extends through the bolt body into the bolt head and connects the two parts during ramming and extraction. Extractor lips, machined in the bolt head, extract spent cartridge cases.

(c) *Gun, housing assembly.* The gun housing assembly (fig. 1-7) is a one-piece casting which

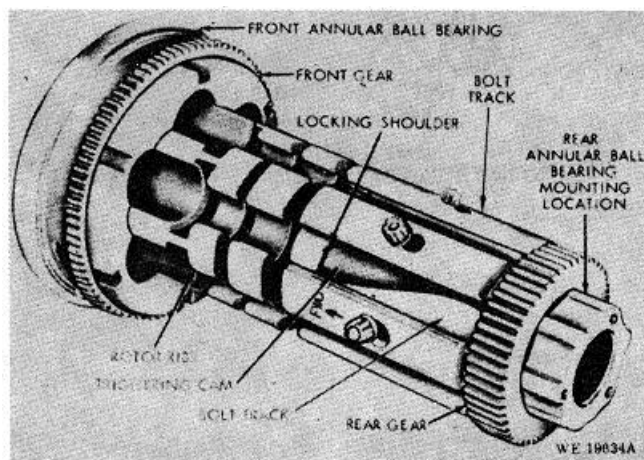

**Figure 1-4. Rotor assembly**

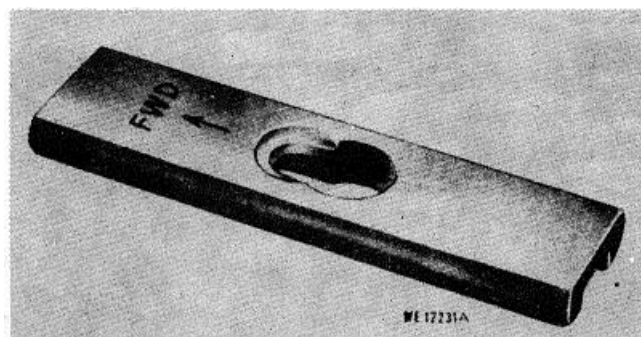

**Figure 1-5. Bolt track.**

covers the rotor assembly and provides a mount for the safing sector, housing cover, and guide bar. The inner surface of the gun housing assembly carries the elliptical main cam of the gun which controls bolt assembly motion.

(d) *Safing sector.* The safing sector (fig. 1-8) is attached to the gun housing assembly by two-quick release pins and acts as a safing device for the gun. The inner surface of the safing sector contains the segment of the cam path which brings bolt assemblies into battery position and allows firing pins to be cocked. When the safing sector is removed, bolt assemblies cannot be cammed into battery by manual or mechanical rotation of the barrels, nor can firing pins be cocked and released by the triggering cam in the rotor assembly.

(e) *Housing cover.* The housing cover (fig. 1-9) is secured to the gun housing assembly and safing sector by two quick-release pins and provides an inspection and service access to the bolt assemblies in position along the upper surface of the rotor assembly.

(f) *Guide bar.* The guide bar (fig. 1-10) is held to the gun housing assembly by a permanently installed pin at the front end and a screw at the rear.

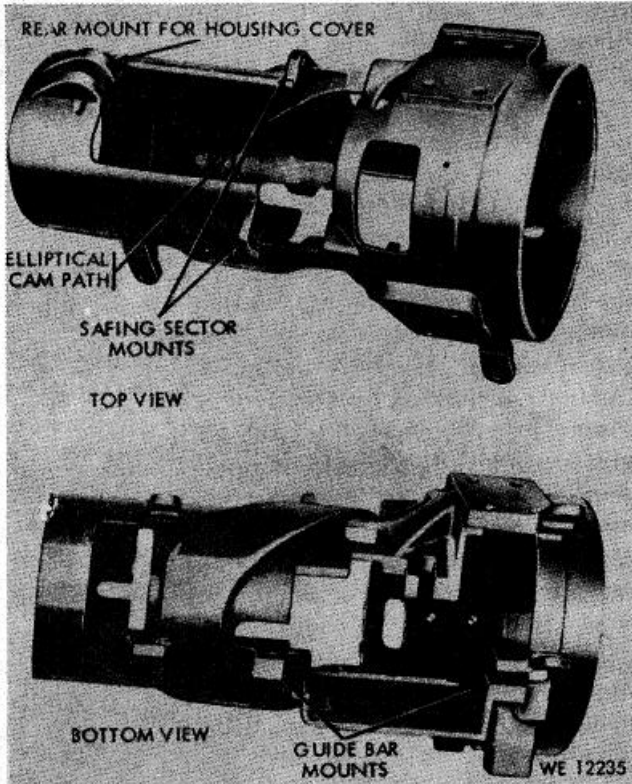

Figure 1-7. Gun housing assembly.

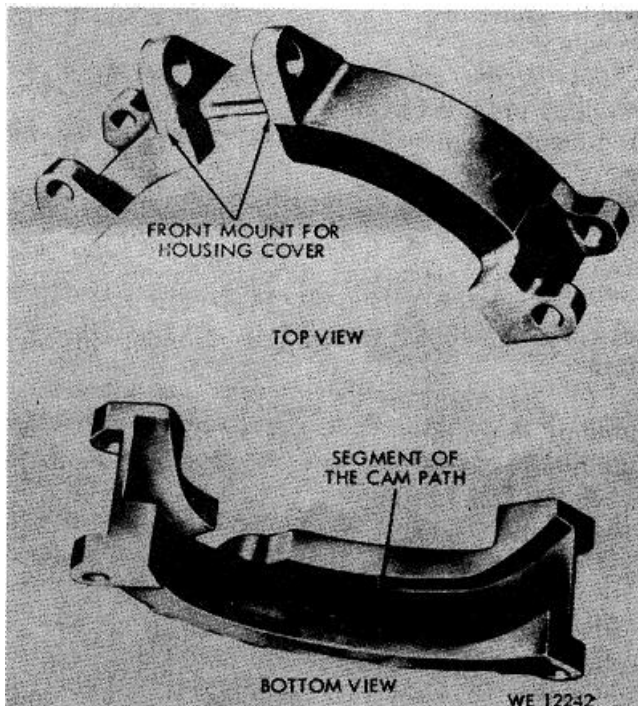

Figure 1-8. Safing sector.

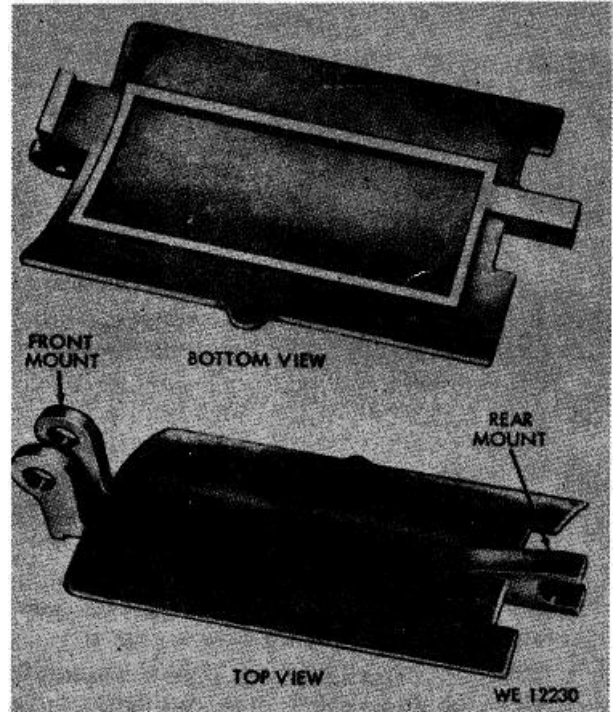

Figure 1-9. Housing cover.

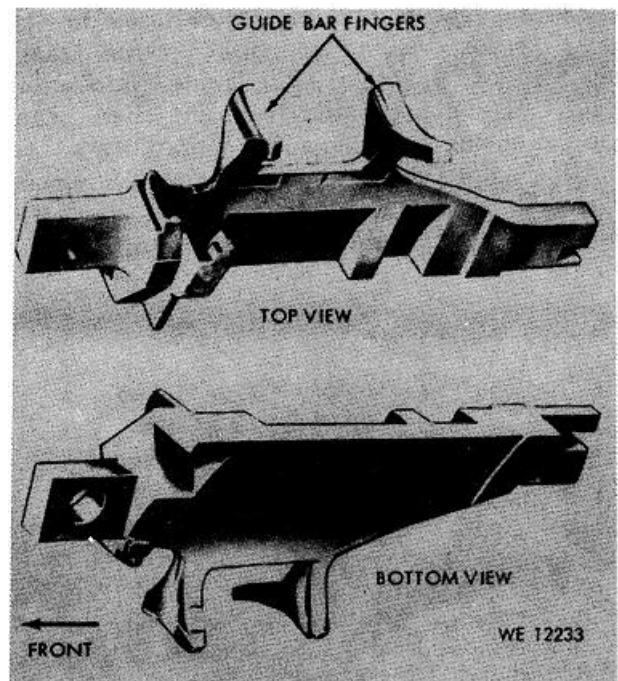

Figure 1-10. Guide bar.

The guide bar fingers direct cartridge cases out of the extractors into the ejection chute.

(g) *Rear gun support.* The rear gun support (fig. 1-11), secured to the rear of the rotor assembly, retains the rotor assembly in the gun housing and serves as the rear support point for the gun.

(h) *Barrel and barrel clamp assembly* (fig. 1-12). Barrels are chambered for the 7.62-MM NATO cartridge. A flange, located near the breech end of the barrel, locks in a rotor groove while the barrel is inserted in the rotor assembly and given a half-turn. Steps along the barrel and at the muzzle provide mounting for the barrel clamp assembly which is locked in place on the barrel cluster by a bolt and self-locking nut.

(2) *Delinking feeder* (fig. 1-2). The delinking feeder conveys the ammunition from the ammunition chute, strips and ejects the links, and feeds the cartridges into the gun.

(3) *Gun electric drive assembly* (fig. 1-2). The gun electric drive consists of an electric motor with a gear housing and a gun drive control assembly. The motor is a dual commutator type and has both series and parallel windings. Motor connections are electronically switched by the control assembly to permit rates of fire of 2,000 rounds per minute (series connection) or 4,000 rounds per minute (parallel connection).

(4) *Sensing unit and cable assembly* (fig. 1-2). The sensing unit and cable assembly (gun clear sensor) is a magnetic pickup that is mounted on a special nose guide plate on the gun. This unit permits counting live rounds ejected during a fire-to-clear operation by transmitting a 1.4 volt pulse as each round is cleared. The cable is permanently attached to the sensing unit and incorporates two connector plugs.

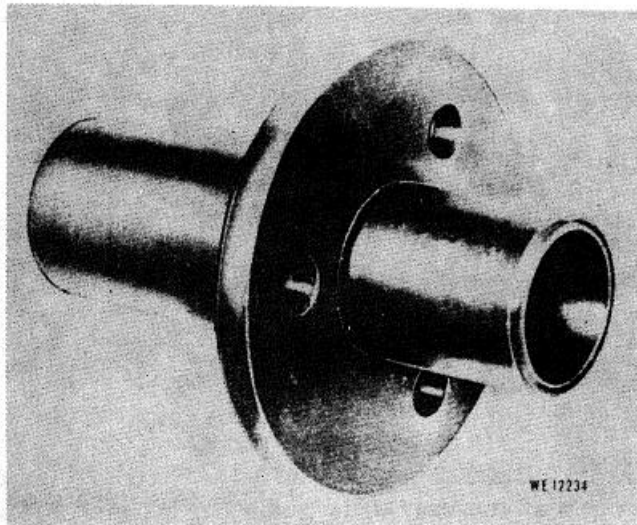

Figure 1-11. Rear gun support.

(5) *Ejection chutes* (fig. 1-2). Two ejection chutes are attached to the delinking feeder to direct ejected links and empty or live cartridges from the gun to the exterior of the fairing.

(6) *Gun mounting adapter* (fig. 1-2). Two adapter fittings are provided to permit quick attachment of the machine gun to the gun mount assembly. One adapter fits into a neoprene lined shock isolator in the mount assembly. The other adapter mates with a single half-turn gun mount lock to secure the weapon in the mount assembly.

b. *Fairing Assembly* (fig. 1-1). The gun fairing assembly is an aerodynamic shaped fiberglass cover which encloses the aft portion of the gun assembly. It consists of upper and lower assemblies. The upper assembly is secured to the mount assembly by means of three wing-type (turn-lock) fasteners. The lower assembly is attached to the upper assembly by seven wingtype (turnlock) fasteners. A ram air duct, bonded to the upper fairing assembly, directs high velocity air into the link ejection chute, insuring that ejected links are thrown clear of the aircraft.

**Warning:** The fairing assembly must be installed for all weapon firing missions, since in-flight firing without ram air duct may result in damage to aircraft tail rotor.

c. *Mount assembly* (fig. 1-13). The mount assembly consists of the following main components:

(1) *Door filler assembly.* A door filler assembly is provided to fair in the opening between the mount assembly torque tube and the aircraft door. The door filler assembly is constructed of flexible plastic and is split on one side so that it can be sprung over the torque tube. The door filler assembly is attached to the aircraft door with five screws. The screws removed from the aircraft armament door are reused in this installation.

(2) *Ammunition container assembly.* The ammunition container is a spotwelded and riveted aluminum assembly with a capacity of 2,000 rounds of ammunition. The assembly includes three spring-loaded ammunition levelers in each of two compartments. Rollers, and an integral crossover chute direct linked ammunition into a mating elbow shaped chute on the housing. The lower forward leveler assembly is provided with an actuating block which extends through the bottom of the container to actuate the ammunition low sensor switch. The ammunition container assembly mounts on top of the housing by

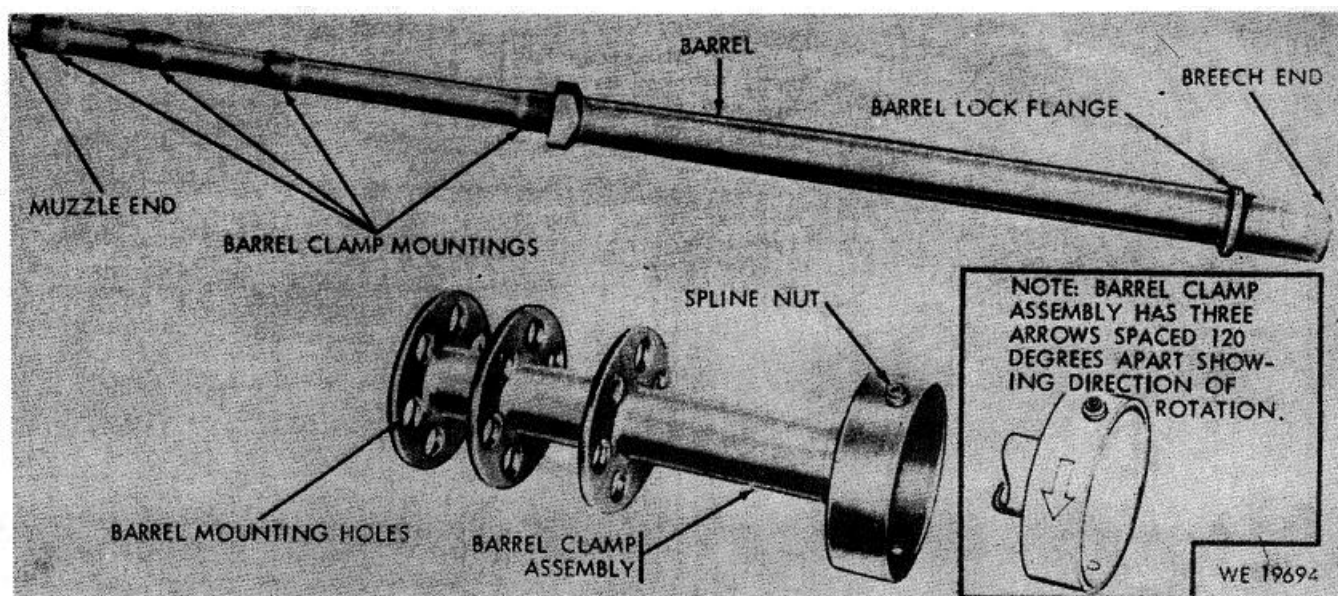

Figure 1-12. Barrel and barrel clamp assembly.

means of two aligning pins, a rectangular shaped locator block, and two latches (fig. 3-17).

(3) *Electrical system assembly.* The electrical system assembly consists basically of the control box assembly and the gun drive cable. The control box assembly is mounted on the front side of the housing assembly and provides electrical control functions and electrical distribution required by the subsystem. The gun drive cable provides electrical connection between the control box assembly and the gun drive control assembly. The gun drive cable consists of a six conductor harness with two electrical connectors.

(4) *Housing and tube assembly.* The housing and tube assembly is a rectangular sheet aluminum structure into which castings are riveted for bearing support and mounting points. It is secured to the helicopter at three points by means of quick release pins. The assembly is provided with bearings which contact a bearing surface around the tube assembly on which the gun is mounted. Rotation of the tube within the housing provides the elevation and depression of the weapon. Rotation is accomplished by an electric motor driven clutch and worm gear mating with a gear segment on the tube assembly. The elevation motor assembly is mounted on the housing and includes an ammunition low sensor switch. Stops are provided on the gear segment to limit elevation to 10 degrees and depression to 24 degrees. A sight drive fitting, part of the tube assembly, is provided for attachment of the sight control rod. An ammunition chute adapter assembly and a torsionally flexible aluminum feed chute

are mounted in the tube assembly. Ammunition, from the ammunition container assembly, passes through the adapter assembly and ammunition feed chute to the delinking feeder.

(5) *Control Rod Assembly.* The control rod assembly provides a link between the tube assembly of the housing and tube assembly and the sight assembly. Thus, movement of the tube assembly in elevation and depression causes corresponding movement of the sight assembly.

d. *Helicopter Reflex Sight XM70E1 (fig. 1-14).* The helicopter reflex sight XM70E1 is an optical sighting instrument synchronized with the movement of the weapon in elevation and depression by a control rod. The sight is adjustable in elevation for ranges of 250 to 1000 meters. The sight mount can be adjusted and locked to a height convenient to the user. A reticle image projector and a beamsplitter plate provide a reticle image that appears superimposed on the target when the weapon is properly aimed. Electrical power for the projector is supplied through a cable connected to the control box assembly. The beamsplitter arm is moved to the left to its stowed position when the sight is not being used.

e. The beamsplitter arm is moved to the left to its stowed position when the sight is not being used.

### 1-5. Armament Subsystem Controls

The following information pertains to controls that are components of the aircraft and are not provided in the subsystem kit.



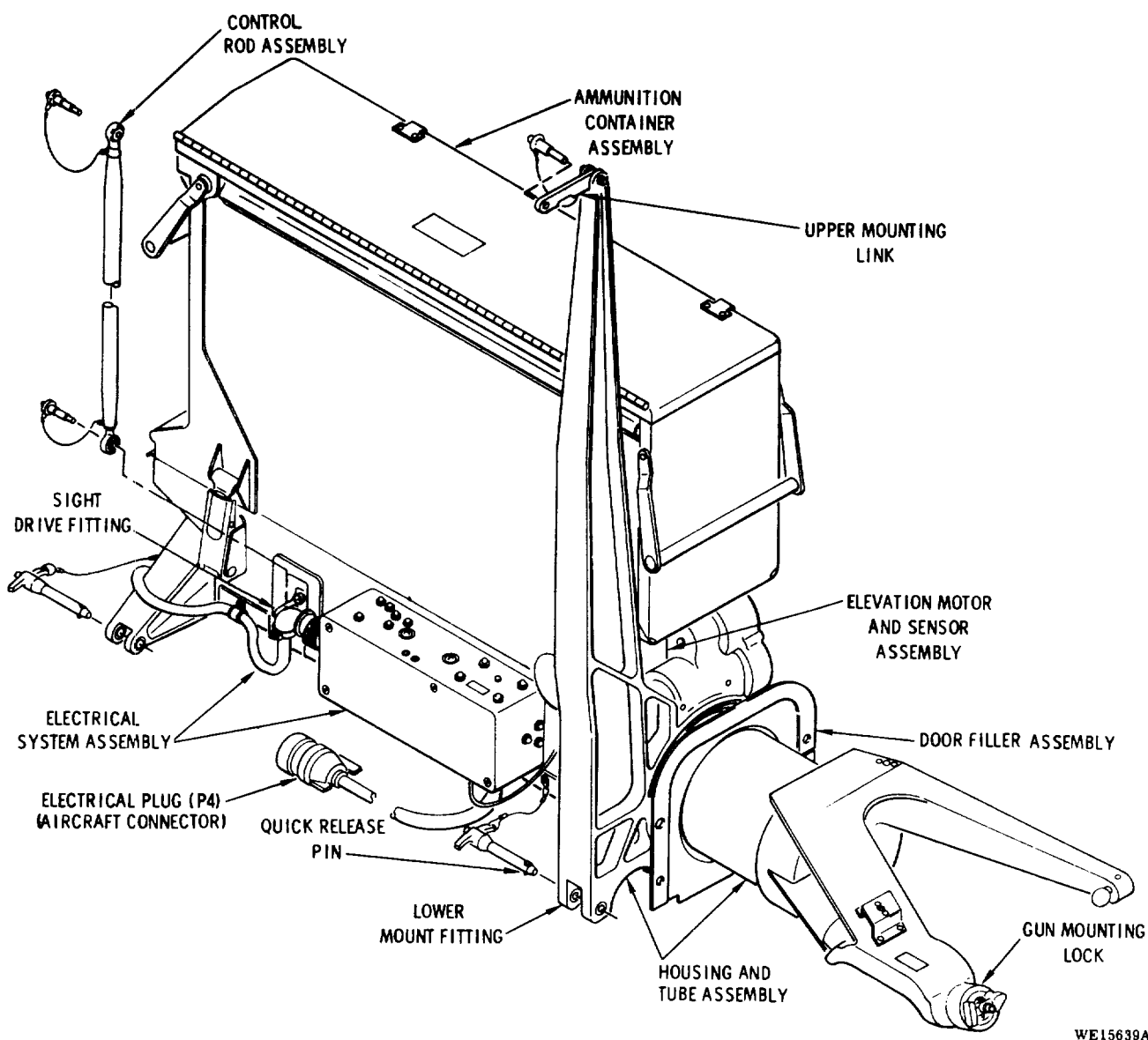

Figure 1-13. Mount assembly.

a. *Electrical Console and Circuit Breaker Panel (fig. 1-15).* Control for external or battery power is provided through the BATT-OFF-EXT (electrical power) switch, the ARM POWER circuit breaker (50 amps), and the ARM circuit breaker (10 amps). Power is 28-volts DC. Additionally, brightness of the armament panel edgelights is controlled by the SW PANEL, a rheostat type switch, on the LIGHTS panel.

b. *Armament Control Panel (fig. 1-16).* The armament control panel provides the following warning lights: GUN NOT CLEARED, ARMED, and AMMO LOW. The SYSTEM MODE MASTER, a rotary type switch, provides for selection of OFF, FIRE TO CLEAR, and FIRE NORM positions and controls power

application to the ARMED-SAFE switch. The ARMED-SAFE switch is a two position, safety toggle type and permits selection of the ARMED position only after the toggle is pulled outward. Power is applied to the pilots trigger switch when the switch is in the ARMED position.

c. *Cyclic Stick Switches (fig. 1-17).* The trigger switch, a guarded type, is located on the forward side of the pilots cyclic stick grip. The switch is pressed to a first or second position, providing a low rate of fire (2000 spm) in the first position and a high rate of fire (4000 spm) in the second position. The switch is safe and inactive until the system is armed. The ELEV-DEP switch is a sliding type located on the upper aft



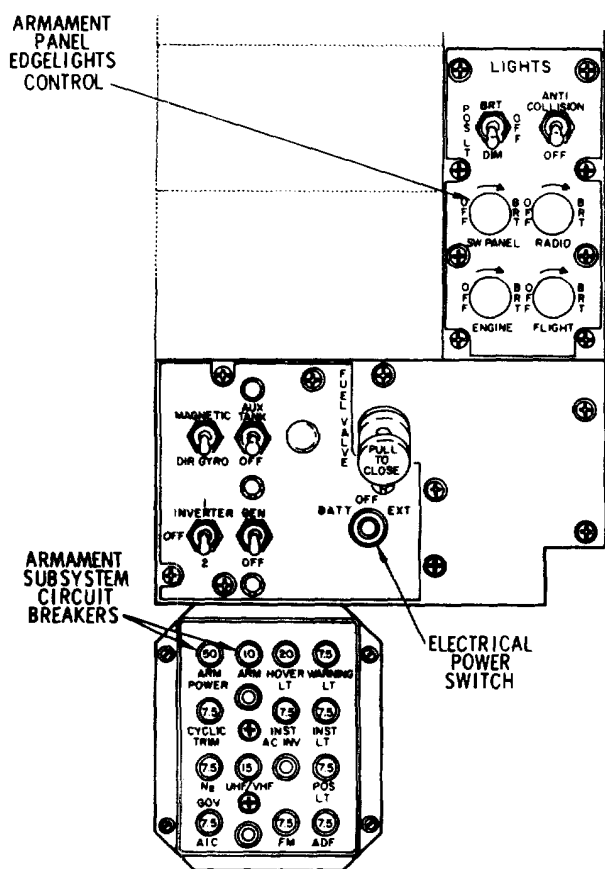

WE 15633

Figure 1-15. Electrical console and circuit breaker panel

f. Subsystem Electrical Characteristics.

- Operating voltage ..... 22-30 Volts DC
  - Drive motor (steady state)..... 40 amp (slow rate max.)  
75 amp (fast rate max.)
  - Lamp (sight) ..... 0.68 amp (each filament)
  - Subsystem temperature range:  
Operable ..... -65 deg F to +165 deg F  
Storage ..... -80 deg F to +165 deg F
- g. Ammunition. Refer to table 4-1.

1-7. Name, Caution, and instruction Plates

Refer to table 1-2.

Table 1-2. Name, Caution, and Instruction Plates

Name	Function or use	Location and/or reference
Identification plate	Nomenclature and serial number	On mount assembly housing
Control box identification plate	Nomenclature and serial number	On bottom of control box
Wiring diagram decal	Control box wiring diagram	On control box cover
Helicopter reflex sight XM70E1 identification decal	Nomenclature and serial number	On side of projector housing
Ammunition box loading procedure	Shows proper method of folding ammunitions into ammunition container	On inside of ammunition container cover
Caution decal	Caution regarding opening of ammunitions container	On ammunition container cover
Delinking feeder MAU-56/A identification plate	Nomenclature and serial number	Between mounting lugs at front of delinking feeder
Delinking feeder MAU-56/A instruction plate	Depicts the correct position of cartridges and links when entering feeder	On forward curved surface of the housing
Drive motor identification	Nomenclature and serial number	On side of motor
No step deal	Designates no step area	On upper fairing assembly
Caution decal	Caution regarding removal of fairing assembly	On upper fairing assembly
Warning decal	Warning regarding region of barrels	On gun support cradle
Caution decal	Caution regarding sight removal	On sight support assembly
Weapon serial number	Weapon identification	On rotor face (para 1-2a)

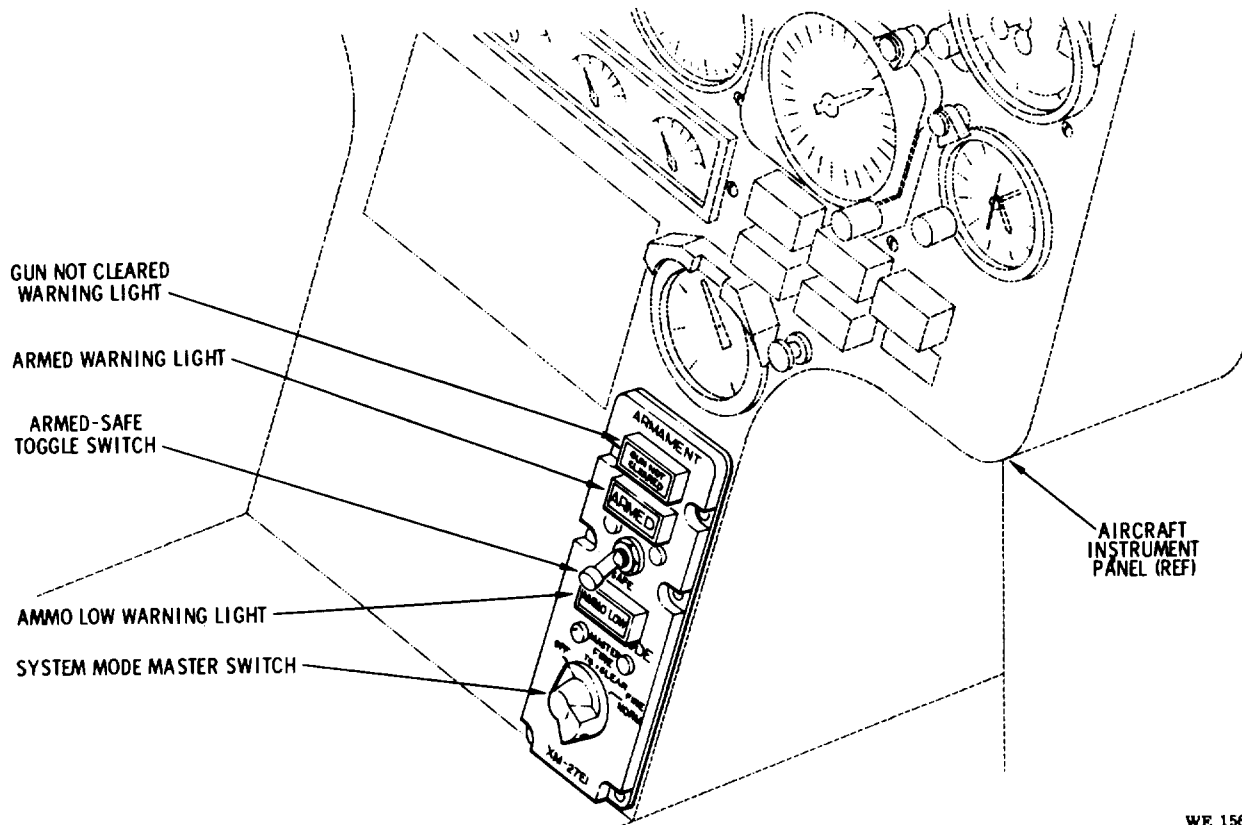

WE 15834

Figure 1-16. Armament control panel

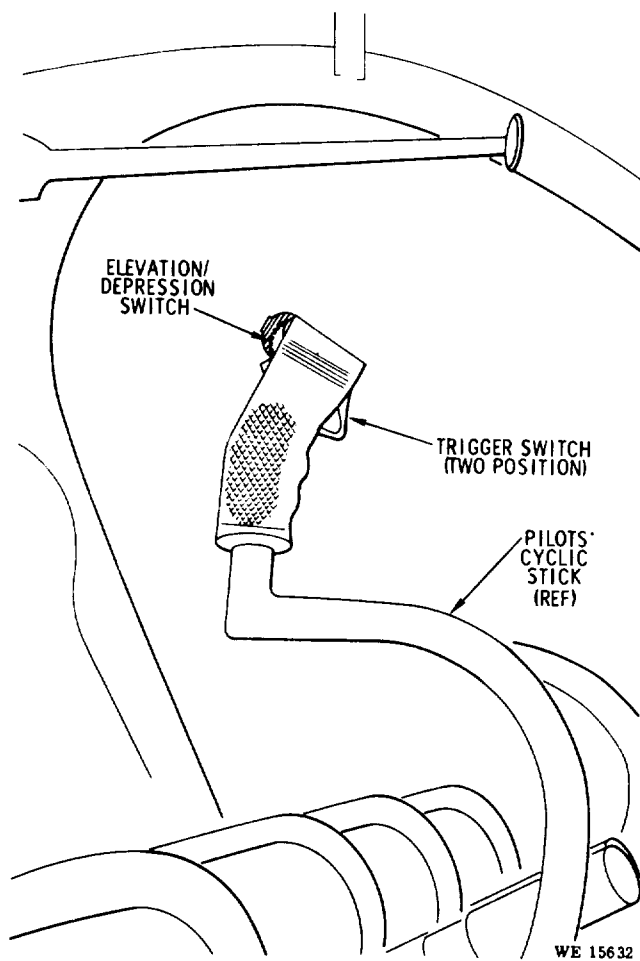

Figure 1-17. Cyclic stick switches.

CHAPTER 2

GROUND CREW OPERATING INSTRUCTIONS

Section I. INSTALLATION AND REMOVAL OF ARMAMENT SUBSYSTEM

2-1. General

The subsystem is installed and prepared for operation using the procedures listed in table 2-1. The procedures referenced provide necessary details for proper installation, removal is accomplished in essentially the reverse order.

2-2. Installation/Removal of Mount Assembly (fig. 2-1).

The following procedure outlines installation of the mount assembly; removal is accomplished in reverse order.

a. If the left cargo door is installed on the aircraft, remove it as follows:

(1) Unlatch and open the left cargo door.

(2) Support the door and remove hinge pins by pulling the jettison control handle inside the aircraft cargo compartment-near the upper forward edge of the door.

(3) Remove the cargo door from the aircraft.

(4) Remove the armament door from the cargo door by removing five screws. Retain these screws for reinstallation.

b. Place the mount assembly in the aircraft and position for attachment to floor fittings and to the upper link fitting on the canted frame (aircraft Sta 78.50).

c. Install two quick-release pins to attach mount assembly to the aircraft cargo floor fittings. Install one quick-release pin to attach upper link to the fitting on the aircraft canted frame. All pins are retained on the mount assembly by lanyards.

d. Connect electrical plug (P4) on harness from mount assembly control box, to the receptacle J200 on aircraft canted frame.

e. Place door filler assembly in position on the mount assembly torque tube.

Table 2-1. Subsystem Installation

Step	Action	Reference
1	Perform initial service and inspection	Table 3-1
2	Install mount assembly	Para 2-2
3	Install reflex sight XM70E1	Para 2-
4	Prepare gun assembly for installation.	Para 2-4
5	Install gun assembly	Para 2-5
6	Perform power off functional check.	Para 2-10
7	Perform power on operational check.	Pars 2-11
8	Install fairing assembly	Para 2-
9	Boresight	Pars 2-12
10	Load the subsystem (if required).	Para 2-16

f. Place aircraft left cargo door in position and support it. Engage the two hinge pins and latch the door securely.

g. Install the door filler assembly in the cargo door using the five screws removed from armament door (para a.(4)) above.

2-3. Installation/Removal of Reflex Sight (fig. 2-2)

The following procedure outlines installation; removal is accomplished in reverse order.

**Caution: Use care when handling the sight to avoid bending the beamsplitter arm or damaging the projector.**

a. Lift the sight into position and engage the two support pins in the aircraft canted frame fitting.

b. Depress the pushbutton in the knob of the sight fastener stud and insert in the aircraft fitting. Release the pushbutton then tighten the knob.

*Note.* The set screw adjacent to the retaining pin is adjusted during bore-sighting procedure.

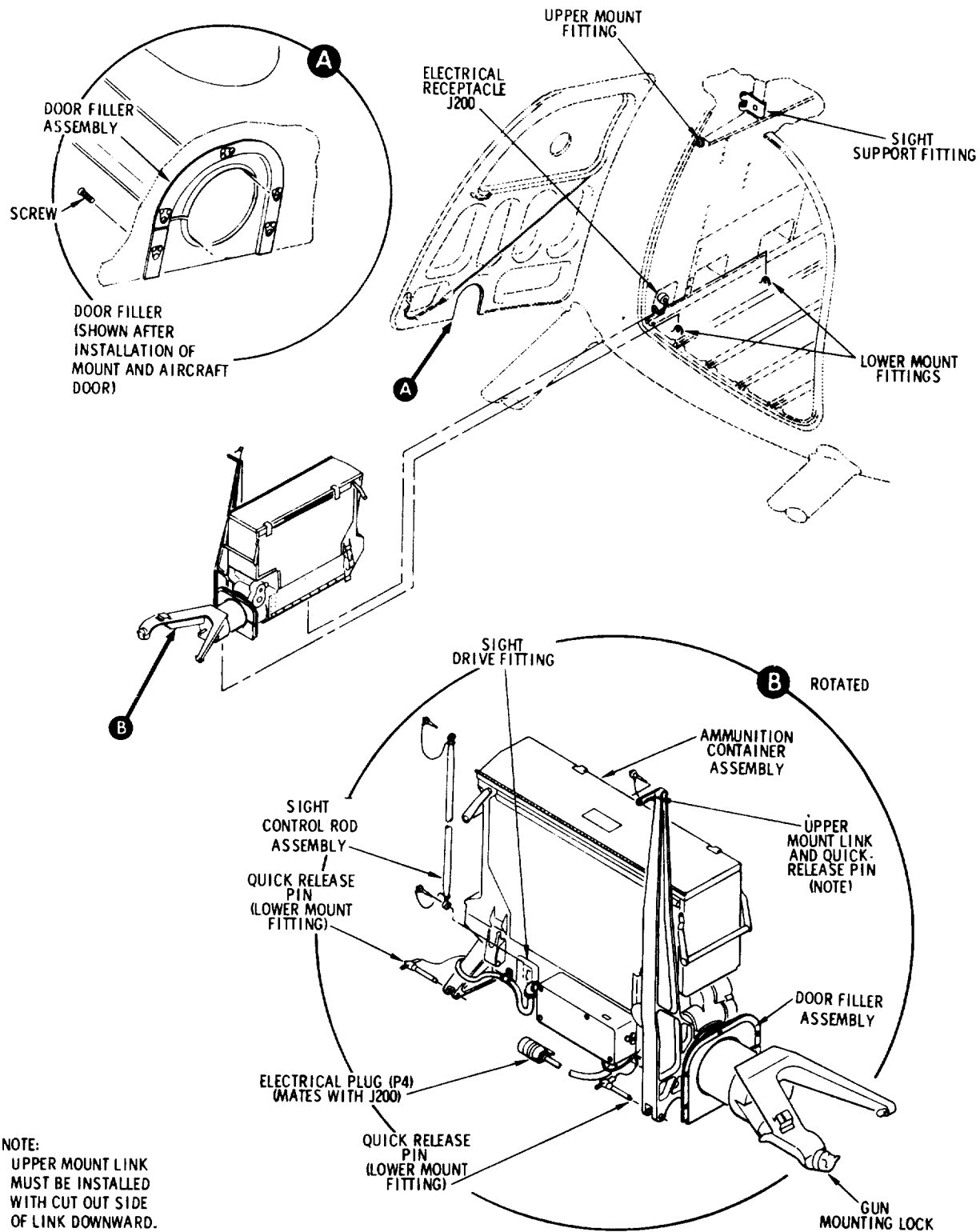

WE15624A

Figure 2-1. Installation/removal of mount assembly.

c. Install the control rod assembly between the sight and mount assembly using the two quick-release pins attached to the control rod assembly. The end of the control rod assembly marked UP shall connect to (the sight bellcrank. Do not change length of control rod assy; boresighting adjustment will be affected.

d. Route the sight electrical harness through the spring clips on the control rod assembly and connect the electrical plug (P3) to the mount assembly control box receptacle (J3).

#### 2-4. Preparation for Installation/Removal of Gun Assembly

The following procedure outlines installation of assemblies and making up the gun assembly. Removal is accomplished in the reverse order.

*Note.* During installation observe torque and safety wiring requirements shown in figure 2-3.

a. Install the following on the gun (27, fig. 2-3):

(1) Install the gun mounting adapters (23) with bolts (21) and washers (22).

(2) Install gun electric drive assembly (26) with bolts (24) and washers (25).

b. Install the following on the delinking feeder (20):

(1) Remove existing nose guide 11686381 and install replacement nose guide 11697451 (11) with screw (10).

(2) Attach cartridge ejection chute (19) with three existing screws (18) at forward end of the delinking feeder.

(3) Install sensing unlit and cable assembly (17) on nose guide (11) with two screws (9).

*Note.* The lower screw (9) extends through the aft attaching point for cartridge ejection chute (19).

(4) Lockwire the screws (9 and 10).

(5) Secure the cable of the sensing unit and cable assembly (17) with clamp (13) and screw (12) and with clamp (15) and screw (14).

(6) Connect electrical plug ((P6) 16) to the gun feed solenoid on the delinking feeder (20).

(7) Attach lanyard (6) to plug ((P5) 7) opposite ground wire, with existing connector screw (4) and nut (5). Attach aft delinking feeder release pin (8) to lanyard (6).

*Note.* The lanyard prevents damage to the sensing unit by preventing removal of the delinking feeder prior to the removal of connector (P5) from the gun electric drive assembly. Make certain that the lanyard is properly installed.

(8) Attach link ejection chute (3) with two existing screws (2) in link guide and two screws (1) in feeder cam housing of the delinking feeder (20).

#### 2-5. Installation/Removal of Gun Assembly (fig. 2-4)

The following procedure outlines installation of the gun assembly. Removal is accomplished in reverse order.

*Note.* Support gun assembly before rotating mount lock lever to unlocked position (red arrow pointing forward) during removal.

a. Hold gun, as assembled (para 2-4a), in position under the mount and engage the aft mount ball.

b. Lift the barrel end of the gun assembly and engage the inboard side mount; then engage the outboard side mount. Turn the side mount lock handle to locked position (red arrow pointing aft). Check the gun assembly for security.

c. Connect gun drive cable connector (P1) to the gun electric drive assembly.

d. Time the gun (fig. 2-5).

*Note.* Additional barrel rotation prior to installation of delinking feeder is cause for retiming.

e. Rotate delinking feeder until feeder timing pin can be depressed.

f. Install delinking feeder, as assembled (para 2-4b), with quick-release pins as shown in figure 2-4.

*Note.* If gun timing pin and delinking feeder timing pin cannot be depressed at the same time, remove delinking feeder and repeat stepsd, e, and f above.

g. Connect electrical plug (P5), part of sensing unit and cable assembly, to the gun electric drive assembly. Check that all other electrical connections are secure.

h. Pull ammunition feed chute to the delinking feeder and connect with the spring pin latch.

#### 2-6. Installation/Removal of Fairing Assembly (fig. 2-4)

The following outlines installation of the flaring assembly, removal is accomplished in the reverse order.

a. Install upper fairing assembly by engaging three turnlock fasteners attaching it to the mount assembly.

b. Install lower fairing assembly by engaging seven turnlock fasteners attaching it to the upper fairing assembly.

**Caution:** When removing upper fairing assembly be sure to unlatch the hidden fastener inside and at the rear of the fairing assembly.



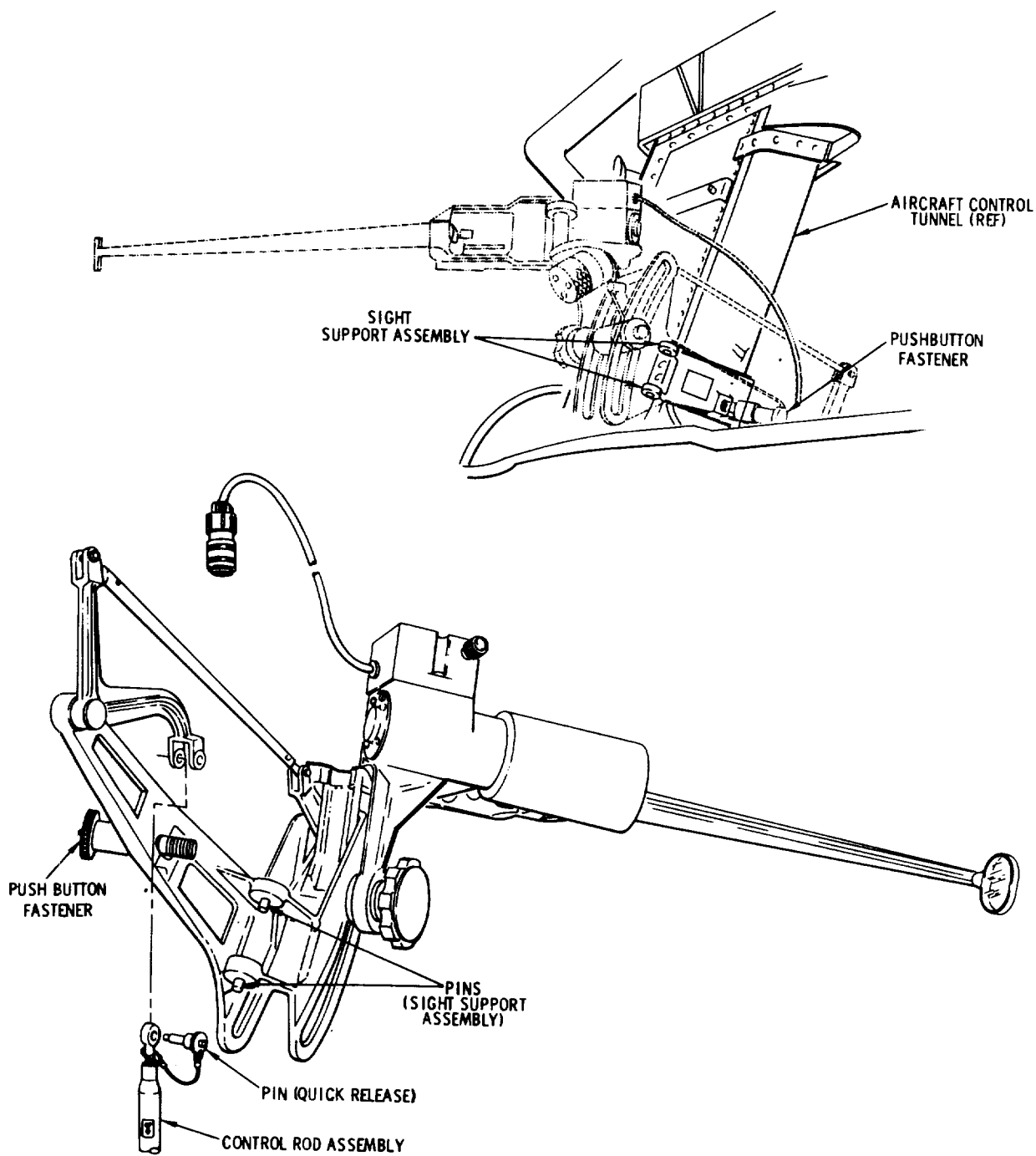

WE 15626A

Figure 2-2. Installation/removal of reflex sight XM70E1.

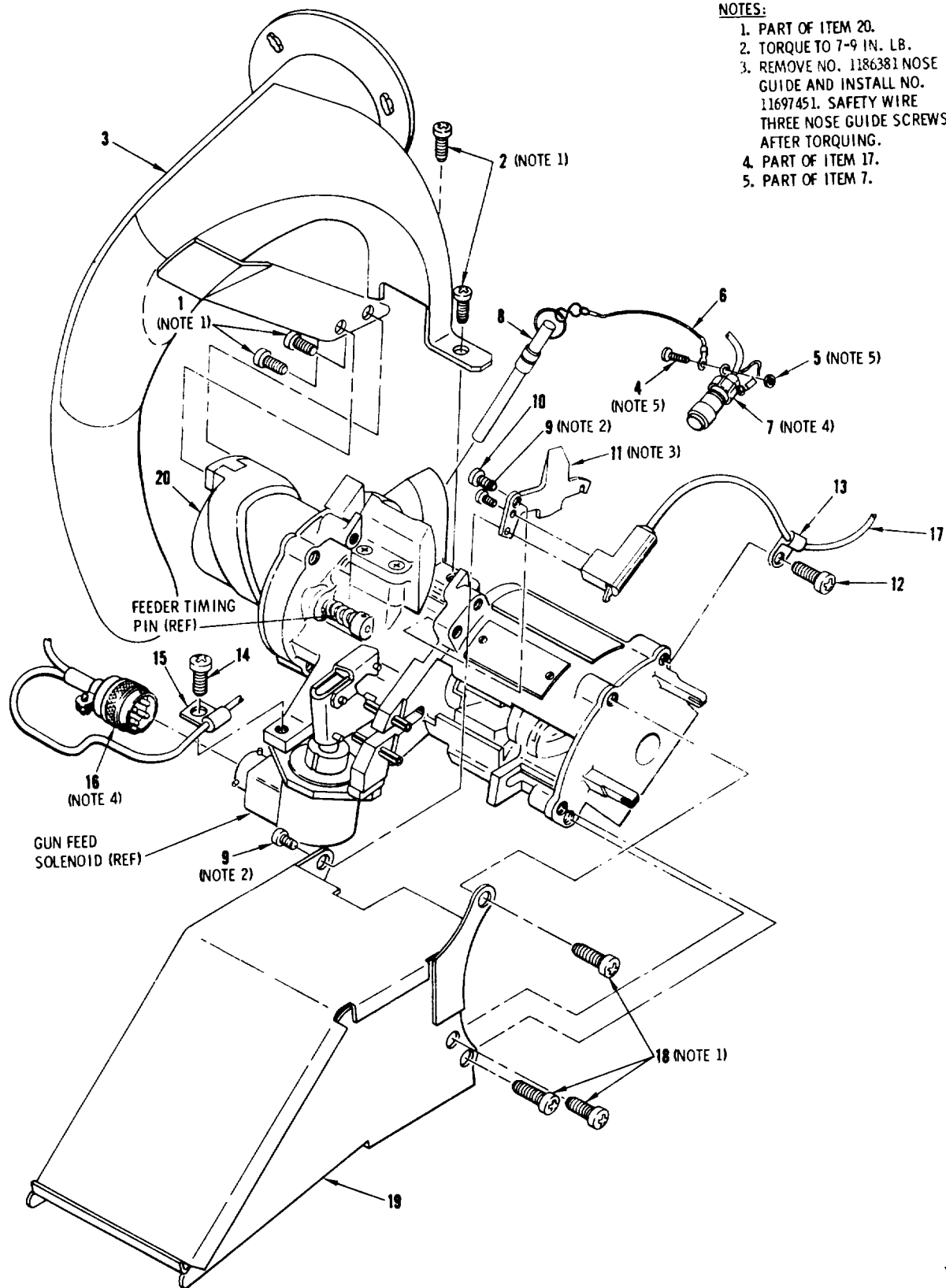
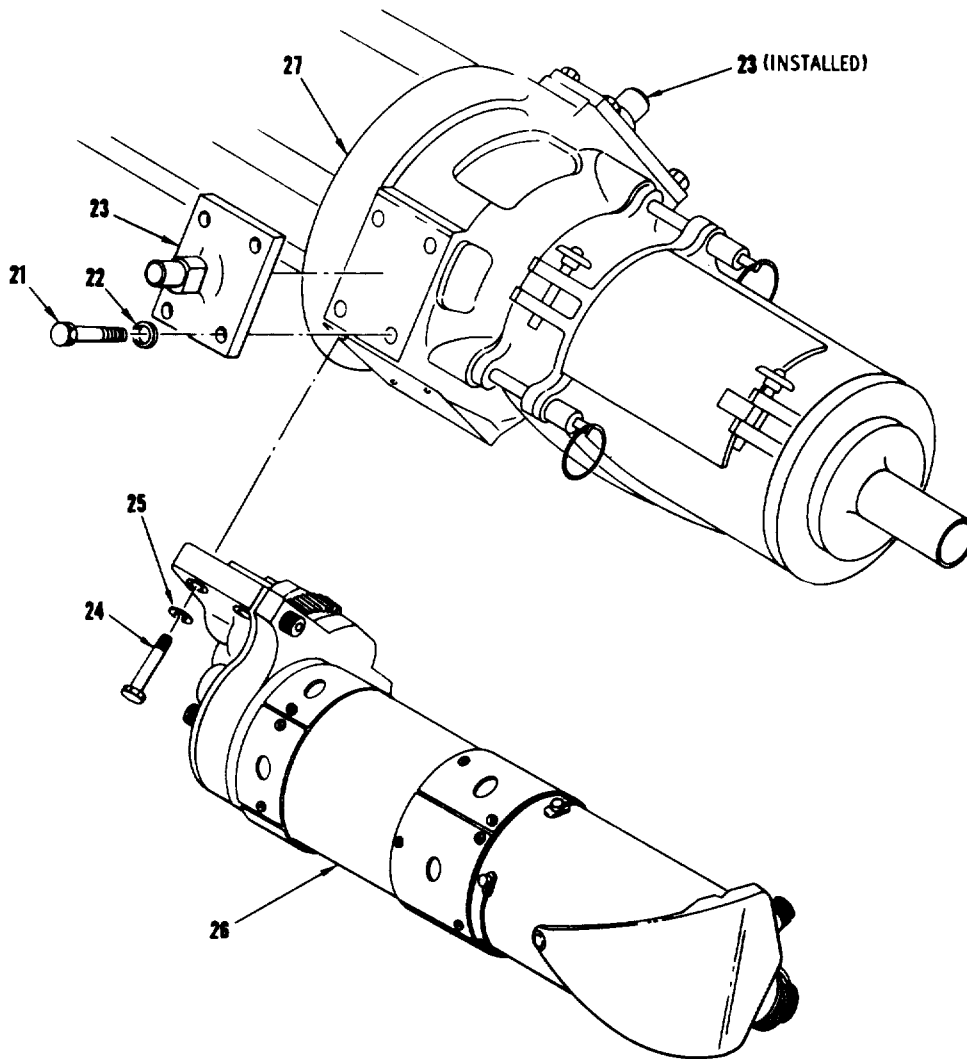

Figure 2-3. Assembly of gun assembly for installation (sheet 1 of 2).



- |                        |                                 |
|------------------------|---------------------------------|
| 1. SCREWS              | 15. CLAMP                       |
| 2. SCREWS              | 16. PLUG (P6)                   |
| 3. LINK EJECTION CHUTE | 17. CABLE AND SENSOR ASSEMBLY   |
| 4. SCREW               | 18. SCREWS                      |
| 5. NUT                 | 19. CARTRIDGE EJECTION CHUTE    |
| 6. LANYARD             | 20. DELINKING FEEDER MAU-56/A   |
| 7. PLUG (P5)           | 21. BOLT                        |
| 8. AFT RELEASE PIN     | 22. WASHER                      |
| 9. SCREWS              | 23. ADAPTER                     |
| 10. SCREW              | 24. BOLT                        |
| 11. NOSE GUIDE         | 25. WASHER                      |
| 12. SCREW              | 26. GUN ELECTRIC DRIVE ASSEMBLY |
| 13. CLAMP              | 27. MACHINE GUN M134            |
| 14. SCREW              |                                 |

WE81296

Figure 2-3. Assembly of gun assembly for installation (sheet 2 of 2)

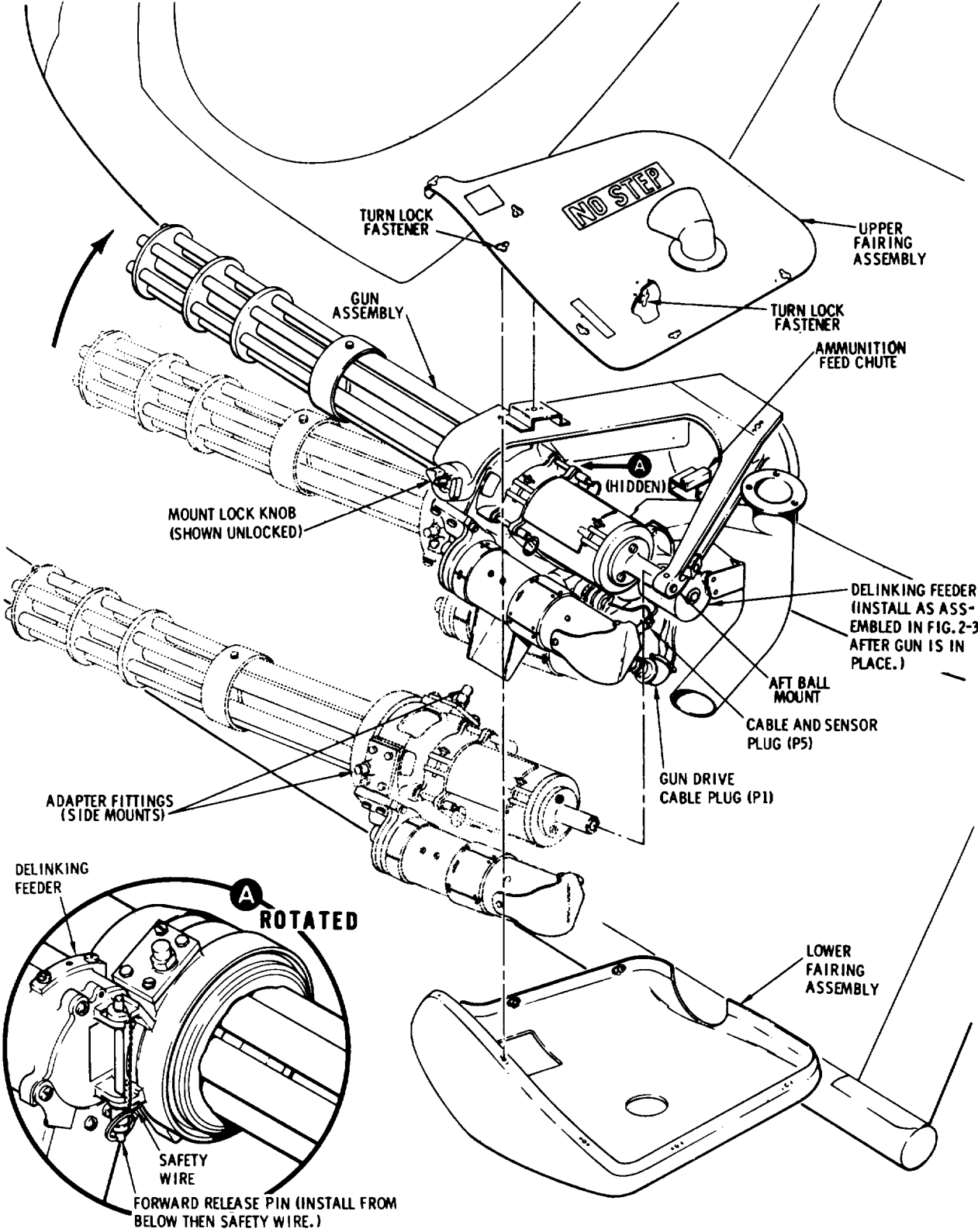

WE 15629A

Figure 2-4. Installation/removal of gun assembly and fairing assembly.

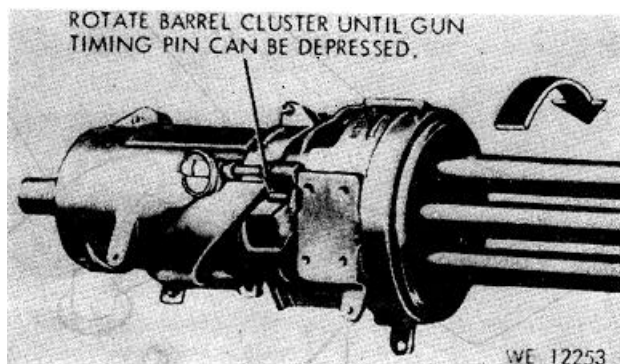

Figure 2-5. Timing the gun.

**Section II. CONTROLS AND INSTRUMENTS**

**2-7. General**

This section describes, locates, illustrates, and furnishes essential information pertaining to the various controls and indicators provided for the proper operation of the subsystem.

pilots compartment of the aircraft. Some of the controls, which are permanent components of the aircraft, are described in paragraph 1-5. The subsystem does not include instruments; however, table 2-2 lists and describes the function of indicating lights and all units that perform any type of control with which the operator should be familiar.

**2-8. Controls and Indicators**

All primary controls for the subsystem are located in the

**Table 2-2. Controls and Indicators**

Control or Instrument	Function	Ref.
	<b>7.62 MILLIMETER MACHINE GUN M134</b>	
Timing pin	Used to establish the firing cycle of the gun.	Fig. 2-5
Safing sector	When safing sector is removed, bolt assemblies cannot be cammed into battery or firing pins cocked and released by rotation of the gun mechanism.	Fig. 1-3
	<b>DELINKING FEEDER MAU-56/A</b>	
Timing pin	Used in conjunction with gun timing pin to synchronize ammunition feed with firing cycle of the gun.	Fig. 2-3
Gun clear sensor	Senses rounds cleared from delinking feeder during gun clearing operation.	Fig. 2-3
	<b>MOUNT ASSEMBLY</b>	
Low ammunition sensor switch	Illuminates a light on armament control panel indicating less than approximately 400 rounds of ammunition remaining.	Fig. 3-17
Reset button	Resets counter (gun cleared logic module) in control box to extinguish GUN NOT CLEAR warning light. Use only after a manual clearing operation has been accomplished.	Fig. 3-19
Manual elevation control	Access door in elevation gear box cover allows manual elevation or depression using a 1/4-inch socket wrench handle.	Fig. 3-17
	<b>ARMAMENT CONTROL PANEL AND CYCLIC STICK SWITCHES</b>	
SYSTEM MODE MASTER switch	Provides mode selections of OFF, FIRE TO CLEAR and FIRE NORM. Operation in fire-to-clear mode is used to clear the gun by preventing gun feeding and by ejecting the live rounds. Operation in fire normal mode or fire-to-clear is limited to 3.0-second burst when the trigger is depressed.	Fig. 1-16

Table 2-2. Controls and Indicators-Continued

Control or Instrument	Function	Ref.
	<b>ARMAMENT CONTROL PANEL AND CYCLIC STICK SWITCHES-Continued</b>	
ARMED/SAFE switch	ARMED position makes the system fully operable.	Fig. 1-16
ARMED light	When illuminated, indicates system is in armed condition and will fire when trigger is depressed.	Fig. 1-16
GUN NOT CLEARED light	When illuminated, indicates that less than seven live rounds have been cleared from the delinking feeder and that ammunition may remain in the gun; consequently the gun will fire if manually rotated. <b>Warning: When the GUN NOT CLEARED light is extinguished, the weapon will not fire during manual rotation; however, if the trigger is depressed the weapon will immediately chamber a round and fire.</b>	Fig. 1-16
AMMO LOW light	When illuminated, indicates less than approximately 400 rounds remaining.	Fig. 1-16
Elevation depression switch	Provides pilot and/or copilot with control of elevation and depression of weapon (may be operated any time aircraft electrical power is on and ARM circuit breaker is depressed).	Fig. 1-17
Trigger switches (on cyclic stick grips)	Permits pilot or copilot to fire at 2000 spm (on first detent) or 4000 spm (on second detent).	Fig. 1-17
Height adjusting knob	<b>HELICOPTER, REFLEX SIGHT XM70E1</b> Permits sight to be moved up or down and locked in place for height adjustment.	Fig. 1-14
Plunger assembly and detent	Provides a means for locking the sight in operating position.	Fig. 1-14
Elevation knob	Used to set the estimated range into the sight. Clockwise rotation elevates the sight.	Fig. 1-14
Range detent plunger	Provides a means of locking the elevation control assembly in the appropriate range scale and provides an audible click at each range setting.	Fig. 1-14
Reticle illumination knob	Controls the intensity of the reticle pattern. Clockwise rotation increases the light intensity (MODE MASTER switch at FIRE TO CLEAR OR FIRE NORM).	Fig. 1-14
Filament selector switch	Provides switching for dual filament reticle projector lamp. If light fails during operation, the second filament can be selected by throwing the switch to the opposite position. Normal switch position is forward.	Fig. 1-14
Boresight adjustment screw	Provides azimuth adjustment.	Fig. 3-22

### Section III. OPERATIONAL CHECKS

#### 2-9. General

Perform operational checks when specified during preventative maintenance (table 3-3) and when directed in other procedures in this manual.

#### 2-10. Operational Check-Power Off

- a. Remove fairing assembly (para 2-6).
- b. Rotate barrel cluster until gun timing pin can be depressed; simultaneously depress gun and delinking feeder timing pin.
- c. Manually clear at least five dummy rounds through delinking feeder; check that moving parts operate smoothly, dummy rounds are ejected without binding or catching, and is not dented.

- d. Manually cycle at least 10 dummy rounds through weapon; check that moving parts operate smoothly, dummy rounds transfer without binding or catching, and brass is not dented.

- e. Install fairing assembly (para 2-6).

#### 2-11. Operational Check-Power On

**Warning: Do not attempt to perform operational checks with ammunition present in gun, delinking feeder, ammunition chutes, or container.**

- a. Connect 28 volt DC power to the aircraft and place BATT-OFF-EXT switch at EXT.
- b. Depress ARM and ARM POWER circuit breakers.

**Caution: Gun operation without ammunition (dry firing) shall be held to a minimum to avoid damaging firing pins. The gun safing sector must be installed to prevent gun jamming and damage to bolt assemblies.**

c. Refer to table 2-3 for check procedure. See figures referenced for location of controls.

**Table 2-3. Operational Checks**

Check sequence	Control	Operation and check	Fig. No.
1	ARMED/SAFE switch	Place in SAFE position	1-16
2	SYSTEM MODE MASTER switch	Place in OFF position. GUN NOT CLEARED, ARMED, AND AMMO LOW lights should be out.	1-16
3	SYSTEM MODE MASTER switch	Place in FIRE TO CLEAR position. AMMO LOW light illuminates. GUN NOT CLEARED and ARMED lights should be out.	1-16
4	ARMED/SAFE switch	Pull out switch and place in ARMED position. ARMED light illuminates.	1-16
5	Cyclic stick trigger switch	Press trigger to fire, either 2,000 or 4,000 spm position. Gun rotates for approximately 3 seconds. GUN NOT CLEARED light illuminates.	1-17
6	SYSTEM MODE MASTER switch	Place in FIRE NORMAL position	1-16
7	Cyclic stick trigger switch	Press trigger to fire. GUN NOT CLEARED light remains on. Gun rotates for approximately 3 seconds if trigger is held down.	1-17
8	SYSTEM MODE MASTER switch	Place in FIRE TO CLEAR position	1-16
9	Cyclic stick trigger switch	Press trigger to fire then immediately release. Gun rotates for approximately 1/4 second after trigger is released. GUN NOT CLEARED light will remain on since seven rounds of ammunition must be expelled to activate the gun cleared logic circuit. Press RESET button on control box to extinguish GUN NOT CLEARED light.	1-17
10	ARMED/SAFE switch	Place in SAFE position	1-16
11	SYSTEM MODE MASTER switch	Place in either FIRE TO CLEAR or FIRE NORMAL position.	1-16
12	Reflex sight filament selector switch	Place in either filament position. Reticle lamp comes on. Switch to other filament position. Reticle lamp comes on. Return switch to the forward position.	1-14
13	Reflex sight reticle illumination knob	Rotate knob. Intensity of light should increase when turning clockwise.	1-14
14	Reflex sight elevation knob -	Rotate knob to increased range, sight depresses. Rotate knob to low range, sight elevates.	1-14
15	Cyclic stick elevation/depression switch	Push aft on switch, weapon and sight elevate. Push forward on switch, weapon and sight depress.	1-17
16	Low ammunition sensor switch	Open cover on ammunition container and depress the lower forward ammunition leveling assembly. AMMO LOW light shall go out.	3-17
17	SYSTEM MODE MASTER switch	Place in OFF position. Check that gun is depressed so it will not interfere with the copilot's door if opened. Turn off helicopter 28 VDC supply.	1-16 1-15

**Section IV. BORESIGHTING**

**2-12. General**

Boresighting should be accomplished under the following circumstances:

a. When reports of firing missions indicate that a boresighting discrepancy may exist.

b. After installing a new or used armament subsystem.

c. After repair, replacement, or a change in length of the control rod assembly.

### 2-13. Boresighting-Distant Aiming Point Method

**Warning: All ammunition must be removed from all parts of the subsystem prior to boresighting.**

a. Select a well defined point target at a distance of 750 meters (820 yards).

*Note.* In areas where space limitations preclude employing a distance of 750 meters for boresighting, refer to paragraph 2-14 for alternative ranges.

b. Remove upper and lower failing assemblies if installed (fig. 2-4). Time gun by depressing timing pin (fig. 2-5); install the adapter (with streamer attached) and boresight (fig. 2-6) in the topmost gun barrel (12 o'clock position).

c. Swing aside the small access door (fig. 3-17) in the elevation gearbox cover. Use a 1/4 inch socket drive handle through the access opening to manually adjust gun elevation.

*Note.* An assistant will be required to observe the distant aiming point through the boresight while adjustment is being made.

d. Sighting through the boresight scope, move helicopter laterally on ground handling wheels until vertical reticle line is centered on target. Adjust gun elevation manually with socket drive handle until the horizontal reticle line is centered on the target.

*Note.* Helicopter leaving is not required, but cant angle should be as small as possible. Weapon elevation position not critical and can be at the elevation required to acquire the point target, but should be kept as near horizontal as practical.

e. Align 750 on the white scale of the elevation knob (fig. 1-14) with the white arrow. The sight is now in boresighting position.

f. Place both the ARM and the ARM POWER circuit breakers (fig. 1-15) in the on position. Place BATT-OFF-EXT switch at BATT (fig. 1-15) and SYSTEM MODE MASTER switch (fig. 1-16), at FIRE-TO-CLEAR to illuminate reticle pattern.

g. Position height of sight for convenient observation of the reticle pattern. Adjust reticle illumination knob (fig. 1-14) for proper reticle intensity.

h. Loosen pushbutton fastener and adjust boresight adjustment screw (fig. 3-22) until the center of the reticle image pattern is coincident with a vertical line running through a point four reticle line widths (2.6 meters) to the left of the point target, as described in step d. Tighten pushbutton fastener stud. Recheck reticle image pattern to make sure the position has remained fixed.

i. Remove sight electrical cable from clips on control rod tube assembly (fig. 3-21). Manually adjust control rod assembly by turning the tube assembly until center of reticle pattern corresponds with a point three reticle line widths (2.1 meters) below the point target, as described in step d.

j. Recheck to make sure the weapon and the sight still indicate the set points described in steps d, h, and i.

k. Remove the boresight, adapter assembly, and streamer from gun. Place electrical controls actuated in step f, above to off position. Install sight electrical cable, removed in step i, above, in control rod assembly clips.

*Note.* The sight to gun relationship has been optimized for the aircraft in flight (100 knots at 100 ft altitude) and therefore the sight will not indicate the proper impact point under static conditions.

### 2-14. Boresighting-Short Range Aiming Point Method

When boresight range limitations dictate the use of boresight points closer than 750 meters, the following deviations in the procedure (para 2-13) must be observed.

a. Use the 750 meter setting on the range knob regardless of the boresight point distance.

b. Loosen the height adjustment knob and lower the sight support assembly to the bottom of its travel.

c. Set the sight reticle image to the azimuth value indicated on the azimuth correction curve (fig. 2-7) appropriate for the distance to the target used by adjusting the boresight (azimuth) adjustment screw (fig. 3-22).

d. Set the sight reticle image to the elevation value indicated on the elevation correction curve appropriate for the distance to the target used by adjusting length of control rod assembly.

*Note.* These curves compensate for the range setting of 750 meters, the elevation displacement of the sight versus gun, and the similar azimuth displacement, for any range up to 750 meters. Examples (using the correction curves) are as follows:

1. For a target distance of 120 meters the sight aim point must be 3.5 mils above and 6.0 mils to the right of the gun boresight point.
2. For a target distance of 360 meters the sight aim point must be 1.6 mils below and 1.6 mils to the left of the gun boresight point.



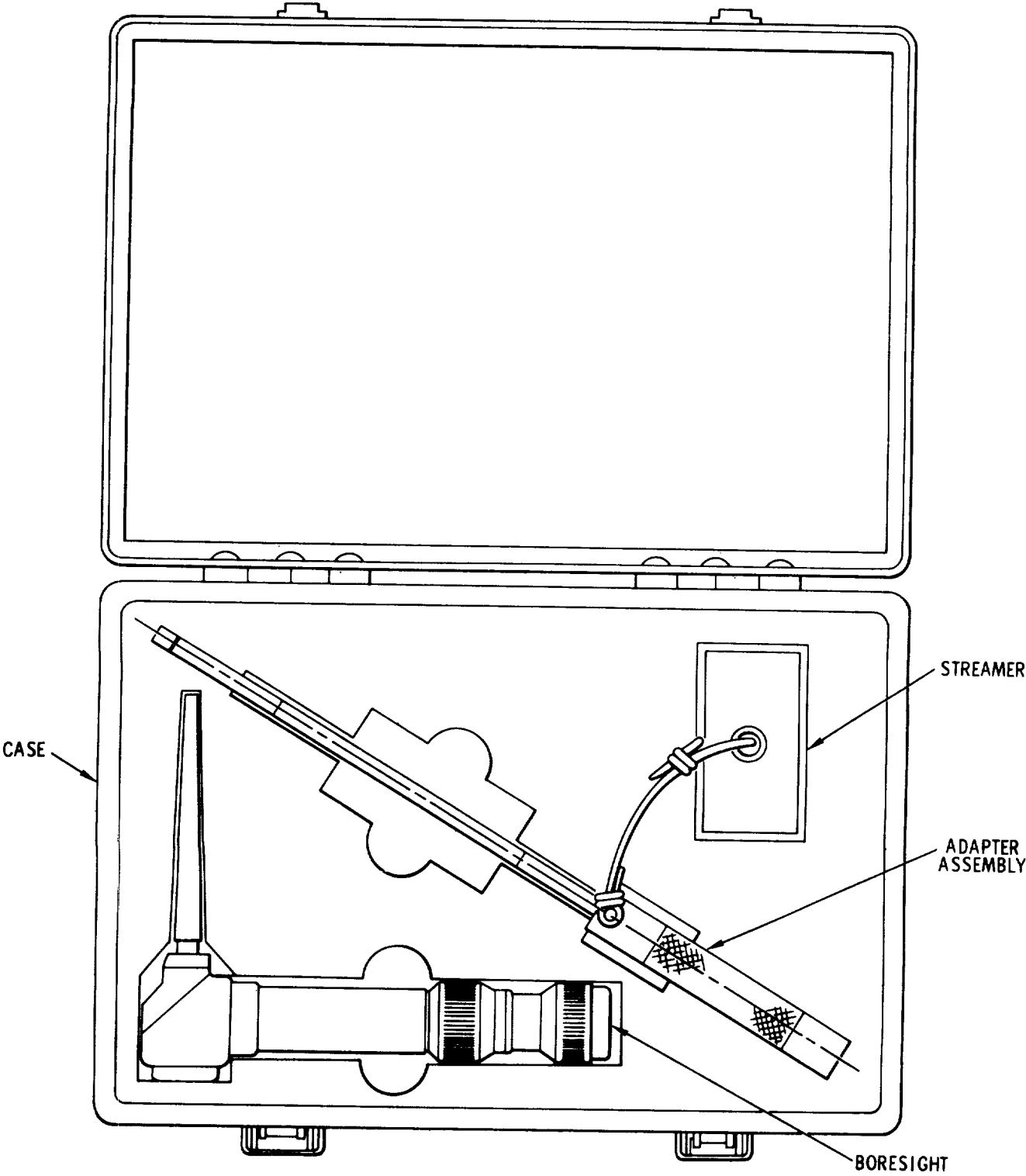

WE 15822

Figure 2-6. Boresight kit.

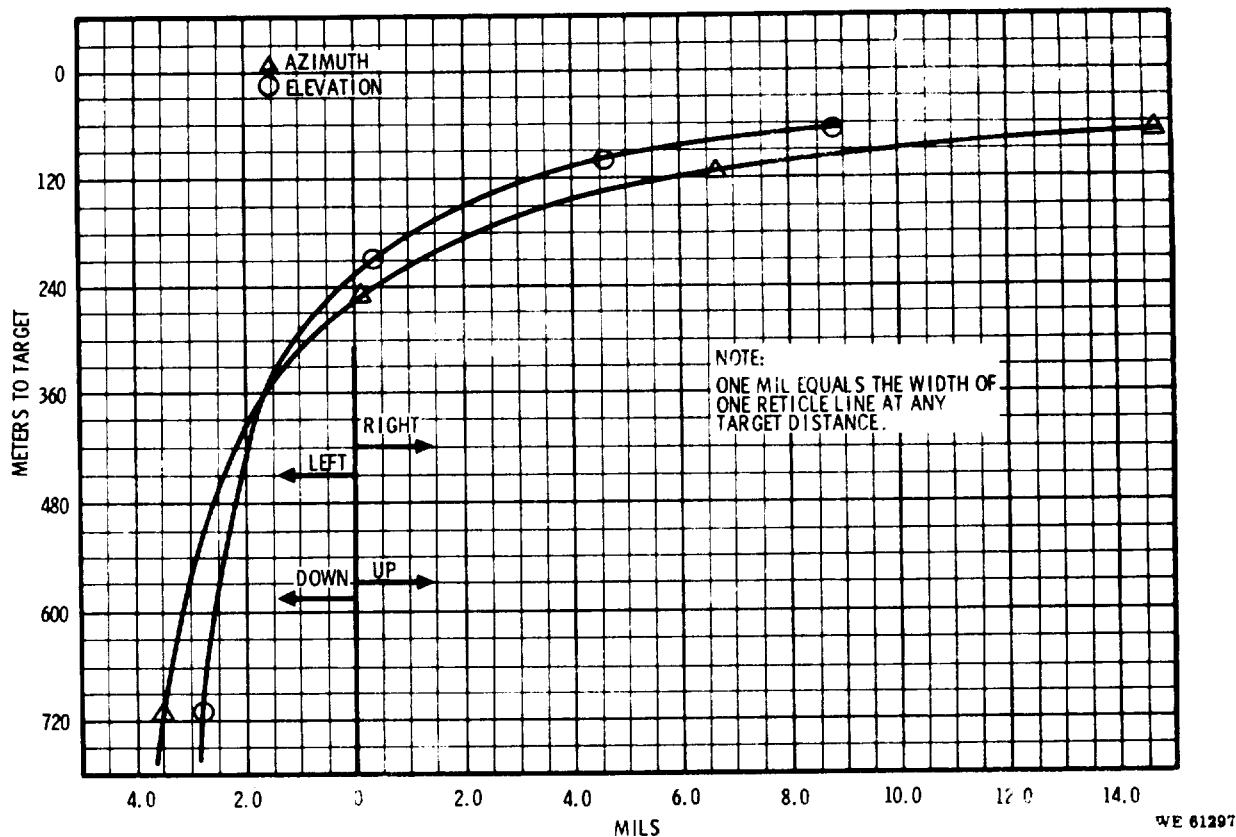

Figure 2-7. Sight-to-boresight relationship for short range targets.

### Section V. OPERATIONAL SERVICES

#### 2-15. Preparation for Loading or Unloading

Load and unload the subsystem only in areas designated for such operations. The helicopter should be headed toward a clear area with the gun directed downward. Electrical power is not required and should not be connected. No other work operations, such as aircraft servicing or maintenance, should be performed while the armament subsystem is being loaded or unloaded.

#### 2-16. Loading Instructions

**Caution: Loading in excess of 2000 rounds can cause jamming.**

a. Prior to loading the gun, check to make sure the following conditions exist:

- (1) Helicopter BATT-OFF-EXT switch OFF.
- (2) Armament SYSTEM MODE MASTER switch OFF and ARMED/SAFE switch in SAFE position.
- (3) Warning lights out.

b. Fold ammunition belt into ammunition container assembly (fig. 2-8) and work it through ammunition

chutes to the delinking feeder.

c. Remove fairing assembly from mount assembly as shown in figure 2-4.

d. Remove safing sector and housing cover from gun as shown in figure 3-5.

**Caution: Do not force a round into the delinking feeder. The first round will be picked up by feeder rotation.**

e. Feed ammunition to delinking feeder by working through open top of ammunition chute.

f. Rotate gun barrels counterclockwise (as viewed from rear of gun) until a round drops from the delinking feeder.

g. Install safing sector and housing cover on gun and install fairing assembly. Close and latch ammunition container assembly cover.

#### 2-17. Unloading and Cleaning Instructions

a. Prior to unloading and clearing the gun, check to make sure the following conditions exist:

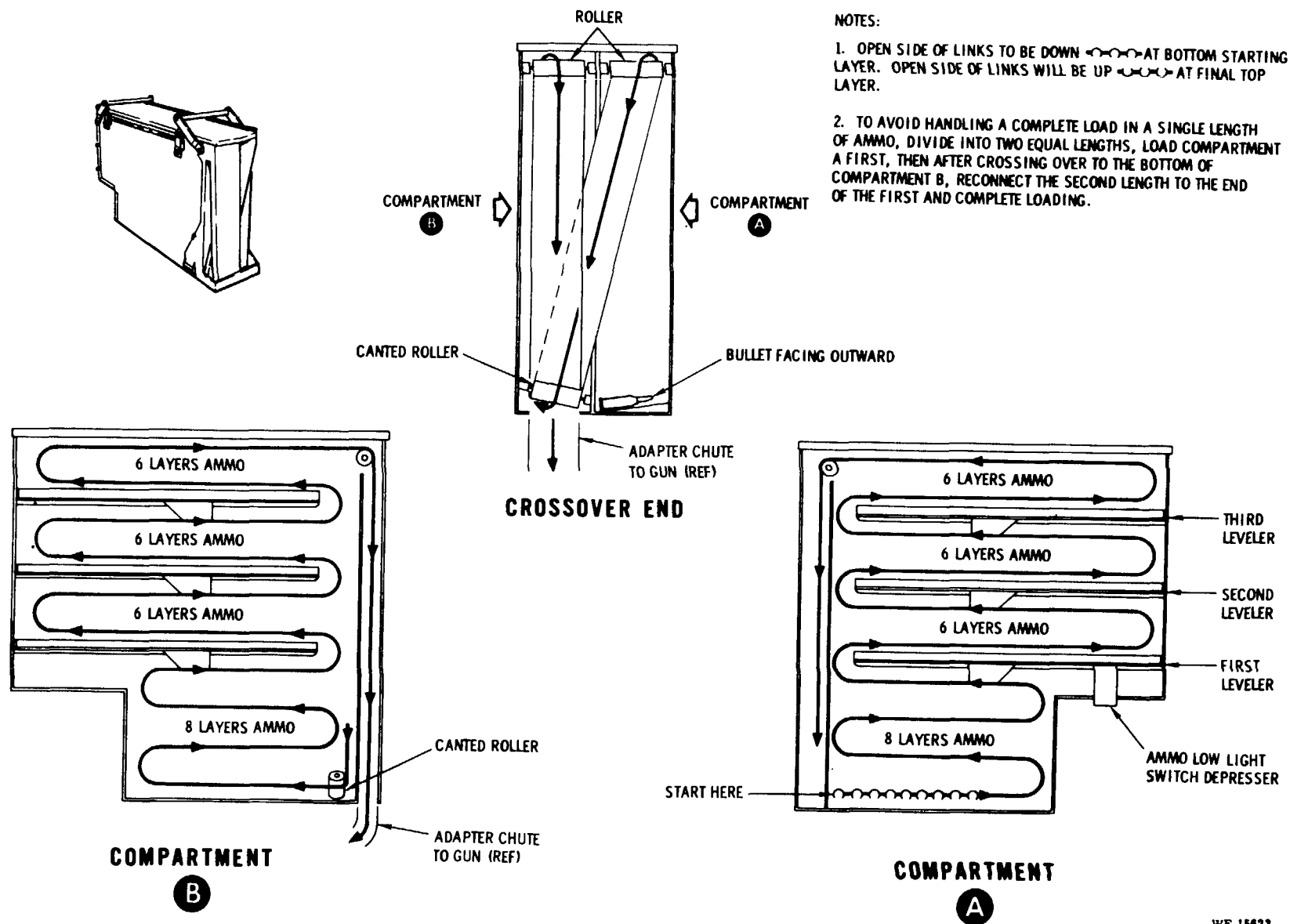

WE 15823

Figure 2-8. Method of loading ammunition container assembly.

- (1) Helicopter BATT-0,FF-EXT switch: OFF.
- (2) SYSTEM MODE MASTER switch: OFF.
- (3) ARMED/SAFE switch: SAFE.
- (4) Warning lights out.

**Warning:** A firing pin may be cocked and ready to be released. Before removing safing sector and housing cover, rotate barrels clockwise (opposite firing direction) slightly to prevent firing. Failure to adhere to these instructions explicitly, can result in discharge of the weapon.

b. Remove fairing assembly (fig. 2-4) from mount assembly and remove safing sector and housing cover from the gun (fig. 3-5).

c. Release ammunition chute from delinking feeder and remove one cartridge from the linked cartridges.

d. Manually rotate barrels counterclockwise, viewed from breech end (firing direction), until remaining cartridges are cleared from delinking feeder and the gun.

e. Open cover on ammunition container assembly and pull linked ammunition from chutes and into ammunition container assembly. Remove ammunition container assembly if required.

## CHAPTER 3

## SERVICE AND MAINTENANCE INSTRUCTIONS

## Section I. SERVICE UPON RECEIPT OF MATERIAL

**3-1. General**

When the subsystem is first received by the using organization, inspect all assemblies and accessories to be sure they are properly assembled, secure, clean, and lubricated. Make a record of any missing parts and of any malfunctions. The shipping containers may be retained for re-use.

**3-2. Initial Service and Inspection**

Refer to table 3-1 for a listing of services and inspections to be performed in order to prepare the subsystem for installation.

*Note.* VCI wrapped weapons, equipment, and parts not for immediate use will be kept stored in the VCI package.

**Table 3-1. Initial Service and Inspection**

Step	Action	Reference
1	Remove components from shipping containers.	Fig. 3-1 and 3-2
2	Remove VCI and clean.	
3	Check for missing or damaged parts.	Appendix B
4	Touch up damaged paint surface.	TM 9-213
5	Lubricate.	LO 9-1005-298-12

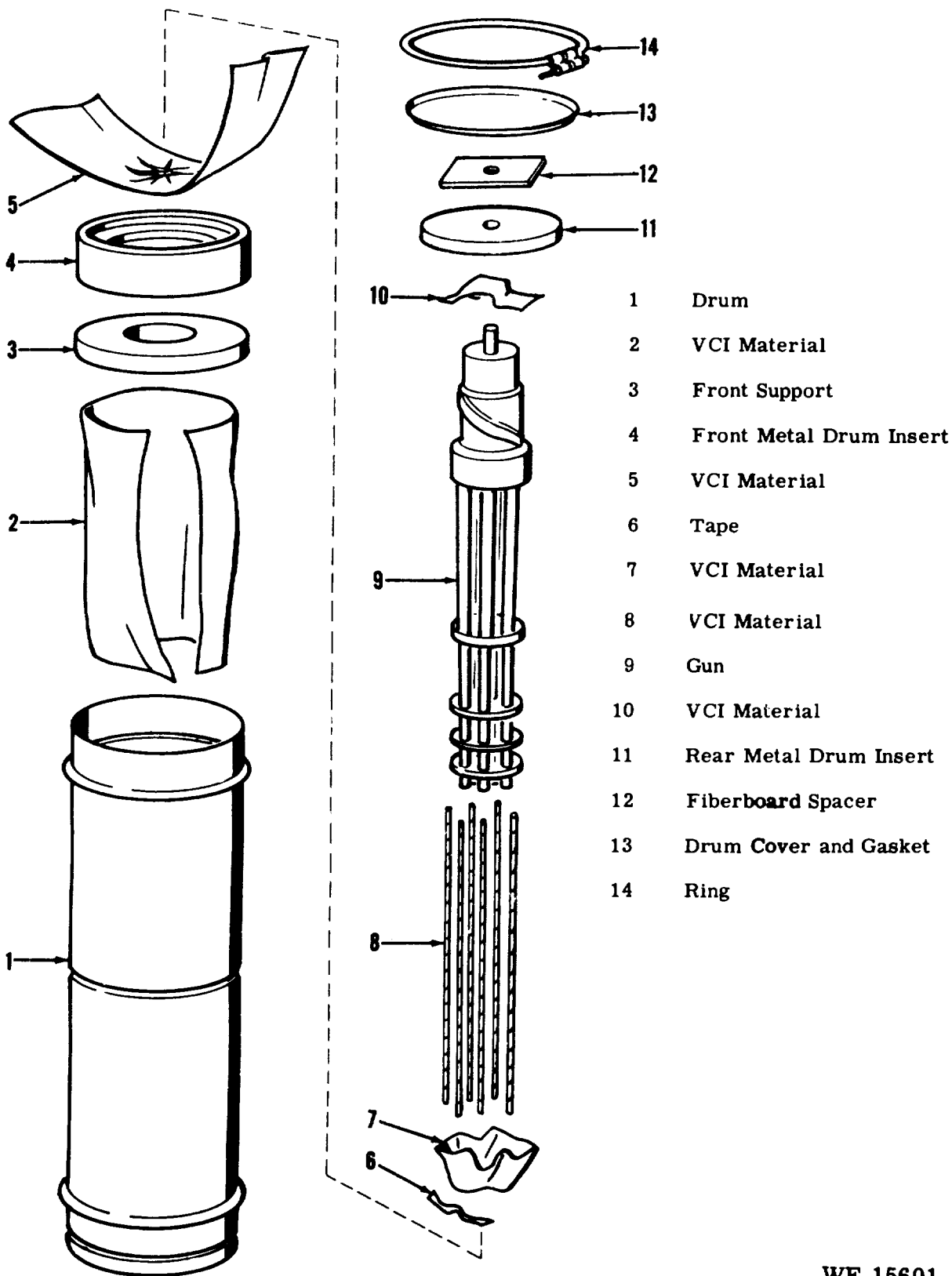
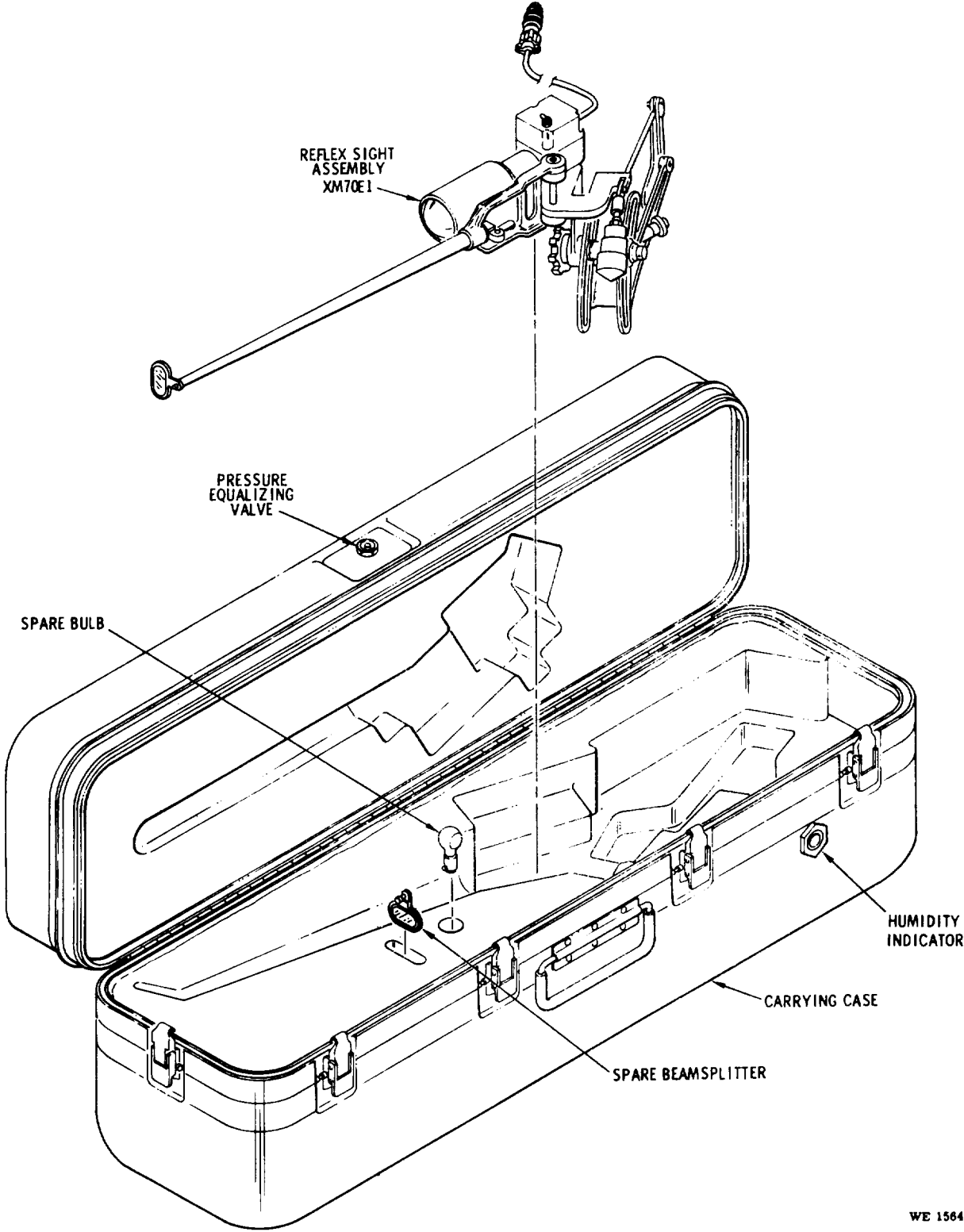

Figure 3-1. Gun and packaging materials.

WE 15601



WE 15640

Figure 3-2. Reflex sight XM70E1 and carrying case.

**Section II. REPAIR PARTS, TOOLS, AND EQUIPMENT**

**3-3. Maintenance Repair Parts**

Refer to TM 9-1005-298-20P for organizational maintenance repair parts.

**3-4. Tools and Equipment**

Refer to table 3-2 for a list of special tools and equipment. Appendix B lists basic issue tools and equipment. Figure 3-3 illustrates tools and equipment used for gun cleaning and maintenance.

**Table 3-2. Special Tools and Equipment**

Item Identifying No.	Reference		Name and use
	Figure	Paragraph	
1 4931-065-1110	3-23	3-26	Nitrogen regulator, hose, and adapter for purging of projector assembly.
2 6830-264-9086	3-23	3-26	Container with dry nitrogen for purging of projector assembly.
3 4931-936-4283	3-23	3-26	Adapter for purging of projector assembly.

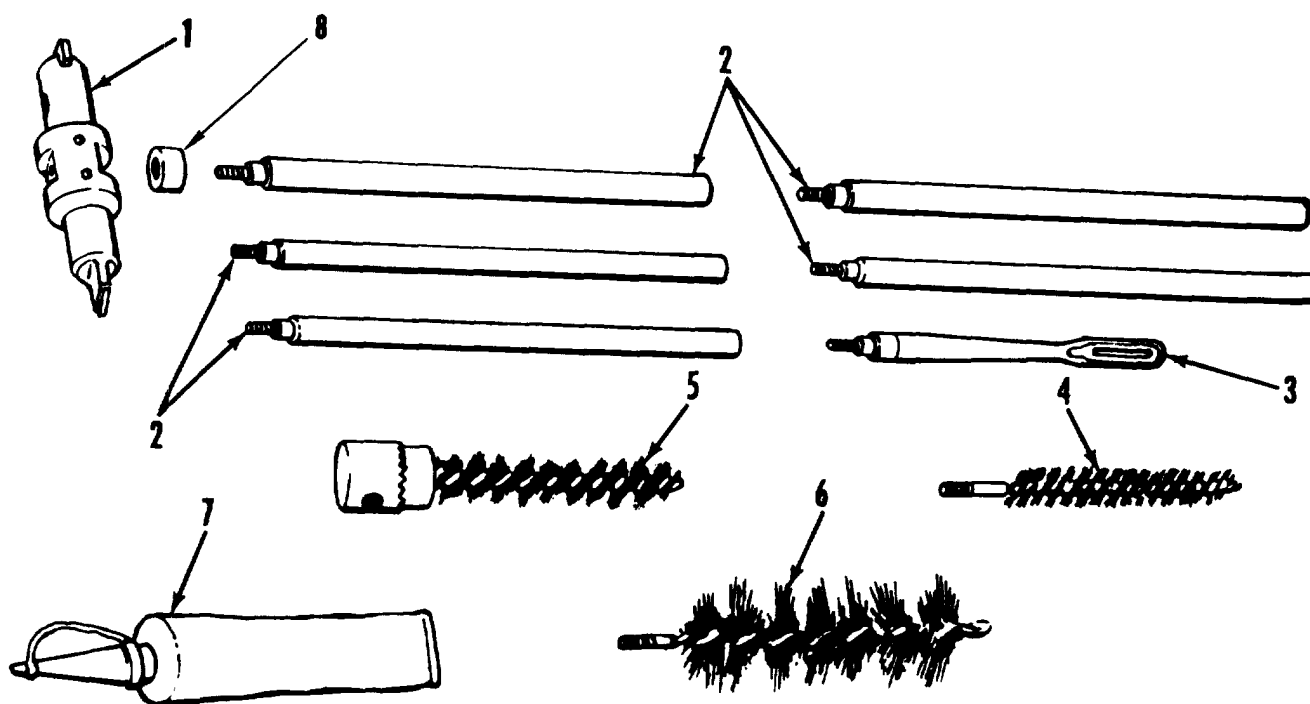

WE 15589B

- 1—Handle assembly
- 2—Rod section
- 3—Swab holder

- 4—Bore brush
- 5—Chamber brush
- 6—Rotor brush

- 7—Lubricating oil
- 8—Buffer

**Figure 3-3. Tools and equipment.**

**Section III. LUBRICATION**

**3-5. General**

Refer to LO 9-1005-298-12 for lubrication and cleaning information.

**Section IV. PREVENTIVE MAINTENANCE CHECKS AND SERVICES**

**3-6. General**

a. Preventive in maintenance is the systematic cleaning, lubricating, and inspection of equipment to

maintain it in serviceable condition, to prevent breakdown, and assure maximum operational readiness. Specific requirements for inspection and service are



and service are found in table 3-3. The item number column provides identification numbers for use in reporting uncorrected deficiencies on DA Form 2404. Intervals of inspection are indicated by an X. The letters designating intervals are defined on the upper right hand column of the table.

**Warning: Do not attempt to perform maintenance operations on a loaded gun.**

b. A schedule for recommended parts replacement is provided in table 3-4.

**Table 3-3. Preventive Maintenance Checks and Services**

Item Number	Interval						B-Before Operation D-During Operation	A-After Operation W-Weekly	M-Monthly Q-Quarterly
	Operator				Org				
	B	D	A	W	M	Q	Item to be inspected	Procedure	Reference
1	X	--	--	--	--	--	Gun barrels	Wipe dry to remove oil, dirt, and other foreign matter from bore and chamber.	Para 3-12a
2	X	--	--	--	--	--	Rotor assembly, bolt assembly, and removable bolt track	Manually rotate gun barrels and inspect moving parts for freedom of movement. Inspect for lubrication.	Para 3-12a
3	X	--	--	--	--	--	Safing sector	Inspect for secure attachment	Para 3-11a
4	X	--	--	--	--	--	Gun and feeder timing pins	See that pins can be depressed at same time.	Para 2-10b
5	--	--	X	--	--	--	Gun barrels	Clean powder fouled surfaces with solvent, wipe dry, and lightly coat with oil.	Para 3-5
6	--	--	X	--	--	--	Gun	Clean external surfaces with solvent and lightly coat with oil.	Para 3-5
7	--	--	--	X	--	--	Gun (overall)	Inspect for dented, loose, or cracked parts	Para 3-10 and 3-12
9	--	--	--	X	--	--	Rotor assembly and bolt assemblies	Manually cycle at least ten rounds of dummy ammunition through gun, checking to see that moving parts operate smoothly; that rounds chamber without binding or catching; that dummy ammunition is not dented or cracked by the operation.	Para 2-10d
10	--	--	--	--	X	--	Gun (overall)	Disassemble, clean with solvent, wipe dry, and lubricate.	Para 3-5 and 3-11
11	X	--	--	--	--	--	Delinking feeder	Manually cycle at least five rounds of dummy ammunition through the delinking feeder. Check that rounds are ejected smoothly without binding or catching and that brass is not dented.	Para 2-10c
13	--	--	--	X	--	--	Sensing unit	Inspect sensor arm and spring for lubrication.	Para 3-5
14	X	--	--	--	--	--	Electrical cable assemblies	Check for damage and loose connections.	Para 2-4 and 3-10b
15	X	--	--	--	--	--	Mount assembly	Check for secure attachment	Para 2-2
16	X	--	--	--	--	--	Ammunition container assembly	See that cover is secure. Check for dents, bulges or damage that would cause ammunition to bind. Check rollers for freedom of rotation and levelers for broken springs.	Para 3-21a and 3-22b
17	X	--	--	--	--	--	Ammunition chutes	Check for proper mating between ammunition container and adapter chute and between the delinking feeder and ammunition feed chute. Check for damage that would restrict ammunition flow.	Para 3-21c and 3-22b

**Table 3-3. Preventative Maintenance Checks and Services-Continued**

Item Number	Interval						B-Before Operation D-During Operation	A-After Operation W-Weekly	M-Monthly Q-Quarterly
	Operator			Org					
	Daily						Item to be inspected	Procedure	Reference
	B	D	A	W	M	Q			
18	--	--	--	--	X	--	Aft ball mount and side mount lock Reflex sight XM70E1	Remove gun and lubricate Clean exterior surfaces and wipe dry. Clean exposed optical surfaces with lens tissue. Check both filaments of reticle lamp; replace if unserviceable. Return switch to forward position. Check detent to insure that sight locks in stowed and operating positions. Clean accumulation of dirt and dust; wipe dry and lubricate.	Para 3-5 Para 3-25
19	X	--	--	--	--	--			
20	--	--	--	--	X	--	Projector linkage	Visually inspect components of the system for damage or missing parts. Check for secure attachments. Clean and lubricate in accordance with lubrication order, LO 9-1005-298-12.	Para 3-25 Para 3-5
21	X	--	X	--	--	--	Subsystem (overall)		
22	--	--	--	X	--	--	Sealed screws and hermetically sealed assemblies.	Check for sealant deterioration. Do not tamper with screws. Check for evidence of internal moisture (lens fogging). Clean and apply light film instrument lubrication oil.	Para 3-26 Para 3-25
23	--	--	--	X	--	--	Mounting surfaces		
24	--	--	--	--	X	--	Painted surfaces	Touch up to prevent corrosion or rust.	TM 9-213

**Table 3-4. Component Replacement Schedule**

Part name	Part number	Replacement schedule (rounds fired)
Machine gun M134	65F9877	Indefinite (500,000 plus)
Pin and spring sets parts kit	5910873	100,000*
Bolt subassembly	63B9865	180,000
Bolt head	65B9867	180,000

**Table 3-4. Component Replacement Schedule-Cont**

Part name	Part number	Replacement schedule (rounds fired)
Removable bolt track	65C9749	180,000
Barrels (6)	11701204	100,000 total (approx 17,000 per barrel)

\*100,000 rounds applies to the life of a new firing pin. Replace spring 63BR10721 as necessary (approx. 50,000 rounds).

**Section V. TROUBLESHOOTING**

**3-7. General**

Troubleshooting is presented in two tables. Table 3-5 provides troubleshooting for defective mechanical components and table 3-6 provides troubleshooting for the electrical system. The tables include tests and corrective actions applicable to the operator and organizational level of maintenance. Generally, organizational level is authorized to test and replace complete assemblies while higher maintenance levels are responsible for operations that require testing, disassembly, and replacement of detail components within assemblies. Notify direct support or general support levels of maintenance for replacement of components not procurable at the organizational level of maintenance. Refer to Maintenance Allocation Chart,

Appendix B, for additional information concerning maintenance responsibilities.

a. When performing electrical troubleshooting, test equipment will be required. The schematic diagram (fig. 3-4) should be used as an aid in tracing the circuits.

b. When troubleshooting calls for energizing the system, connect 28 VDC electrical power to the aircraft to prevent excessive battery drain. The armament control panel and aircraft controls will be positioned as follows:

**Warning: Do not attempt to troubleshoot a loaded weapon. Remove all ammunition from the subsystem before applying electrical power.**

- (1) BATT-OFF-EXT switch at EXT (or BATT if external power is not available).
- (2) ARM and ARM POWER circuit breakers depressed.
- (3) SYSTEM MODE MASTER switch at FIRE NORM.
- (4) ARMED/SAFE switch at ARMED.
- (5) Normal indications at this time are GUN NOT CLEAR light off and AMMO LOW light on.

**Note.** A preliminary test of all indicator lights on the armament control panel can be made by depressing the LIGHTS TEST pushbutton at the upper center of the aircraft instrument panel.

c. When electrical troubles are isolated to the aircraft components, notify the aircraft electrical equipment repairman.

**Table 3-5. Troubleshooting Mechanical Components**

Malfunction	Probable causes	Corrective action
	<b>GUN ASSEMBLY</b>	
Fails to rotate or fire	Defective electrical system component Damaged cartridge in gun  Foreign material in barrel chamber(s)  Damaged bolt assemblies Damaged delinking feeder	Refer to table 3-6. Clear gun and check ammunition for damaged cartridges. Remove material and clean barrel(s) and chamber(s). Replace as required. Repair by replacing broken shear pins or replace delinking feeder.
Rotates but will not fire	Damaged or unserviceable cartridges Linked cartridges separated  Broken firing pin Broken firing pin spring Damaged bolt heads Burred firing pins or bolt heads	Clear gun and check ammunition lot. Link cartridges or replace defective links. Replace Replace Replace Remove burrs
Gun does not clear during fire-to-clear operation	Gun stops rotating too quickly due to dirty or damaged mechanism. Gun clear sensor arm or spring damaged.	Disassemble, clean, check for damaged parts, lubricate, and reassemble. Replace damaged parts
Fires but rate is low	Defective electrical system Gun dirty, not properly lubricated, or both. Burred or damaged bolt assemblies	Refer to table 3-6. Clean and lubricate.  Inspect and remove burrs replace bolt assemblies.
Stops firing	Burred or damaged cam tracks in rotor assembly housing. Damaged cartridge Bolt head separated from bolt assembly.	Inspect and remove burrs; repair or replace as required. Clear gun. Remove bolt head and replace firing bolt head assembly.
Fails to feed	Damaged rotor assembly Damaged or broken guide bar Delinking feeder mistimed   Bent or broken fingers on gun housing. Damaged or broken extractor on bolt head.	Replace gun. Notify DS Maintenance Retime delinking feeder. After a stoppage, the gun should be timed with all associated feed units in each of the six timing positions. If binding or resistance is observed with either the gun timing pin or the delinking feeder timing pin, check for bent pins in the rotor assembly and check for bent pins in the delinking feeder. Notify DS Maintenance.  Replace bolt assembly.

**Table 3-5. Troubleshooting Mechanical Components-Continued**

Malfunction	Probable causes	Corrective action
Flails to extract	<p align="center"><b>GUN ASSEMBLY-Continued</b></p> Damaged or broken extractor on bolt head. Bent or broken guide bar allows round to feed ahead of bolt assembly. Damaged rim on cartridge	Replace bolt assembly.  Notify DS Maintenance.  Clean gun. Inspect for bent or damaged parts which would damage rim on cartridge.
Fails to eject	Bent or broken guide bar Damaged gun housing assembly	Notify DS Maintenance. Notify DS Maintenance.
Excessive dispersion of bullets	Barrels heat warped or excessively worn rifling. Loose barrel clamp allows barrel movement.	Replace barrels.  Tighten barrel clamp.
Mount will not; elevate or depress	<p align="center"><b>MOUNT ASSEMBLY</b></p> Defective electrical system component Defective gear segment or mechanical stop. Defective clutch assembly Torque tube binds in housing	Refer to table 3-6. Notify DS Maintenance.  Notify DS Maintenance Notify DS Maintenance.
Ammunition does not feed properly	Dirty or damaged ammunition chutes or container assembly.	Clean and make required replacements.
Firing rate low	Excessive pull required on linked ammunition.	Replace defective ammunition chutes, rollers, or leveler assemblies.
No light visible in reticle projector	<p align="center"><b>REFLEX SIGHT XM70E1</b></p> Defective electrical system component One filament burned out	Refer to table 3-6 Switch to other filament; replace bulb.
Light does not reach full brightness	Lamp positioned incorrectly area adjacent to lenses.	Remove and insert lamp with frosted
Light does not reach full brightness	Defective rheostat No lamp in reticle projector Support arm improperly positioned or detent loose.	Notify DS Maintenance. Install lamp. Insure that arm assembly is locked in operating position. Tighten detent in arm.
Reticle pattern not sharp or clear	Optical elements may be dirty, wet, or fogged.	Clean with lens tissue.
Elevation knob binds	Optical elements not positioned properly. Improper lubrication	Notify DS Maintenance. Notify DS Maintenance.
Looseness between fitted parts	Bent shaft Excessive wear Screws not secure	Notify DS Maintenance. Notify DS Maintenance. Notify DS Maintenance.

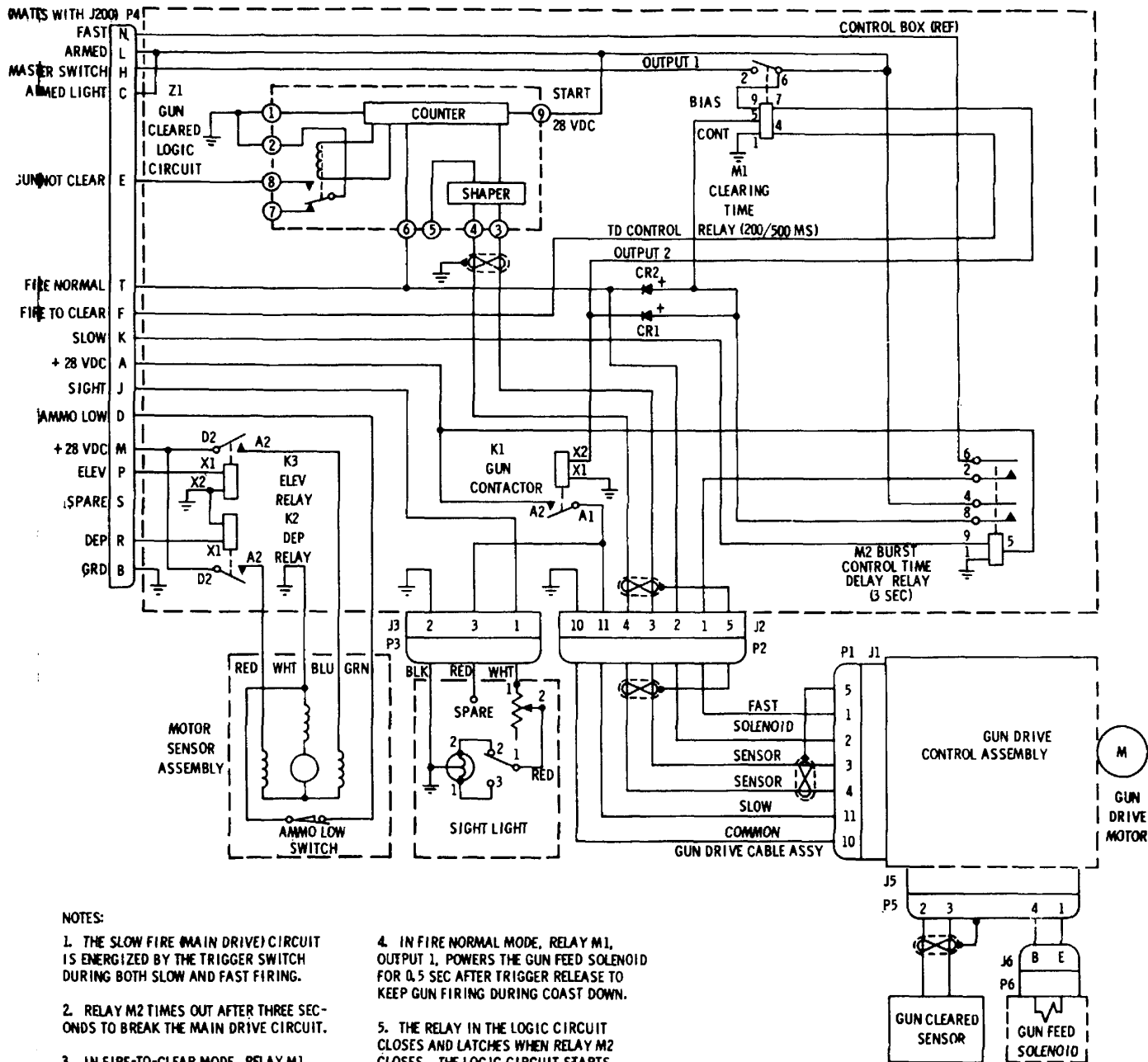

WE15619A

Figure 3-4. Armament subsystem XM27E1-schematic diagram.

**Table 3-6. Troubleshooting Electrical Checks**

Malfunction	Probable cause	Action required for check	Check between	Normal meter reading (supply voltage 28 VDC)	Procedure	
					Meter reading normal	Meter reading abnormal
Gun does not rotate (circuit breakers may open)	Defective motor or speed control.	Determine that gun is not mechanically jammed, refer to table 3-56.	<b>Motor and Speed Control</b> P1-10 and P1-11 (trigger at first detent)	28 VDC	Isolate fault to motor or speed control.	Refer to heading: CIRCUITRY.
		Disconnect plug (P1) at motor speed control.	P1-10 and P1-11.	28 VDC		
		Energize system.	P1-10 and P1-11 (trigger at second detent)	28 VDC		
<i>Note.</i> During electrical troubleshooting, do not operate gun drive motor unless specifically required. Disconnect plug P1 to prevent operation.						
Gun rotates at slow rate but will not change to fast rate.	Defective speed control.	Remove speed control from motor. Reconnect plug (P1) to speed control. See figure 3-15.	SCR1 and E1 (trigger at first detent)	28 VDC	Continue speed control checks.	Replace speed control
		Install jumper between SCR1 and SCR2.	CR4 and E1 (trigger at first detent)	28 VDC		
		Remove jumper.	SCR2 and SCR1 (trigger at second detent)	28 VDC		
Gun rotates at slow rate but will not change to fast rate.	Defective speed control.	Disconnect plug (P1) at speed control.	P1 and P1-10 P1 and P1-11 (trigger at second detent)	28 VDC 28 VDC	Replace speed control.	Refer to heading: CIRCUIT FAULTS.
		Defective control box, wiring, or armament control panel.	Disconnect plug (P2) at control box and energize system.	<b>Circuitry</b> J2-10 and J11		
J2-210 and J2-2 (trigger at first detent)	28 VDC					
J2-10 and J2-U	28 VDC					
J2-10 and J2-2	28 VDC					
Gun does not rotate (fault not in gun motor or speed control).	Defective control box, wiring, or armament control panel.	Disconnect plug (P2) at control box and energize system.	J2-10 and J2-1 (trigger at second detent)	28 VDC	Replace gun drive cable.	Faulty control box or aircraft circuit.
			J2-10 and J2-1 (trigger at second detent)	28 VDC		

Table 3-6. Troubleshooting Electrical Check-Continued

Malfunction	Probable cause	Action required for check	Check between	Normal meter reading (supply voltage 28 VDC)	Procedure	
					Meter reading normal	Meter reading abnormal
Circuitry-Continued						
Gun does not fire circuit (ejects live ammunition).	Defective gun feed solenoid or circuit.	Disconnect plug (P4) at aircraft receptacle (J200).	J200-M and GRD	28 VDC	Continue circuit checks.	Master or ARM/SAFE witch faulty.
			J200-M and GRD	28 VDC		
			J200-A and GRD	28 VDC		
			J200-K and GRD (trigger at first detent)	28 VDC		
			J200-K and GRD	28 VDC		
			J200-K and GRD (trigger at second at detent)	28 VDC		
Gun NOT CLEARED light remain on after firing to clear.	Gun not clear (less than seven live rounds ejected).	Disconnect plug (P6) at gun feed solenoid. Energize system. Disconnect plug (P1) at gun motor speed control. Disconnect plug (P2) at control box. detent) Disconnect plug (P4) at aircraft receptacle.	P6-B and P6E	28 VDC	28 VDC faulty (if linkage Replace speed control.	Gun feed solenoid checks. not jammed). Continue circuit checks.
			P1-2 and P1-10 (trigger detent)	28 VDC		
			J2-2 and J2-10	28 VDC		
			J200-N and J200-B	28 VDC		
GUN NOT CLEARED light remain on after firing to clear.	Defective gun cleared sensor.	Clear the gun (refer to gun unloading and clearing procedure). Press RESET button on control box to extinguish GUN NOT CLEARED light. Disconnect plug (PS) at motor speed control and plug (P2) at control box.	J5-2 and P2-3 J5-3 and P24	Continuity	Gun drive cable or	Replace gun drive checks. Trigger switch or aircraft circuit faulty. speed control wiring faulty. Replace sensing unit assembly if there are no apparent mechanical faults such as a broken spring or arm.

Table 3-6. Troubleshooting Electrical Check-Continued

Malfunction	Probable cause	Action required for check	Check between	Normal meter reading (supply voltage 28 VDC)	Procedure	
					Meter reading normal	Meter reading abnormal
Gun rotates for excessive length of time after trigger release during fire to clear.	M1 relay time delay inadequate or faulty logic module (Z1). Defective control box (M1 clearing time relay).	Disconnect plug (P1) at motor speed control. Energize system on FIRE TO CLEAR.	P1-10 and P1-11 (trigger at first detent then release)	28 VDC (for approx 1/4 second after trigger is released)	No fault.	Replace control box if 28 VDC is observed for excessive time after trigger release.
Gun elevation motor operation faulty.	Defective control box (relay K2) or aircraft circuit.	Disconnect plug (P4) at aircraft receptacle (J200). Energize system	J200-M and GRD	28 VDC	Continue check	Aircraft ARM circuit breaker or wiring faulty.
AMMO LOW light inoperative (bulb okay).	Defective ammo low switch or wiring.	Remove control box cover.	J200-R and GRD (Pilot's switch at DEP)	28 VDC	Continue checks.	Aircraft wiring or elevate-depress switch faulty.
			J200-R and GRD (Pilot's switch at ELEV)	28 VDC	Continue checks.	Aircraft wiring or elevate-depress switch faulty.
			Red wire at TB1-Fp and GRD (Pilot's switch at DEP)	28 VDC	Replace elevation motor.	Replace control box (relay K2 faulty).
Sight light inoperative.	Defective bulb.	Remove ammunition container assembly and determine that there are no defects. Remove control box cover. Energize system. Disconnect plug (P3) at control box. Energize system.	Blue wire at TB1-Ep and GRD (Pilot's switch at ELEV)	28 VDC	Replace elevation motor.	Replace control box (relay K3 faulty).
			Apply ground to green wire at TB1-A19	AMMO LOW light illuminated	Replace elevation motor and sensor assy (witch faulty).	Aircraft wiring or control panel faulty.
			J3-1 and J3-2	28 VDC	Replace sight bulb. If operation not normal, make continuity check on sight cable.	Aircraft wiring or control panel faulty.



## Section VI. MAINTENANCE OF GUN ASSEMBLY

### 3-8. Installation/Removal (fig. 2-4)

Refer to paragraph 25.

### 3-9. Disassembly/Assembly (fig. 2-3)

Refer to paragraph 2-4 for procedures detailing the assembly or disassembly of the gun assembly into its major components. Disassembly, assembly, cleaning, inspection, and repair of the machine gun M134, delinking feeder MAU-56, and gun electric drive assembly are found in Sections VII, VIII, and IX (respectively). The remaining components for the gun assembly require no assembly or disassembly.

### 3-10. Cleaning, Inspection, and Repair

a. *Cleaning.* Clean components in accordance

with LO 9-1005-298-12.

#### Caution:

**Do not allow cleaning solvent to enter sensing unit.**

b. *Inspection.*

(1) Inspect sensing unit and cable assembly for frayed insulation, broken wires, and damaged connector pins.

(2) Inspect nose guide for bends, breaks, or cracks.

(3) Inspect ejection chutes for cracks, dents, or bends that can restrict ejection.

c. *Repair.* Repairs are limited to replacement of parts available at organizational level. Refer to TM 9-1005-298-20P

## Section VII. MAINTENANCE OF MACHINE GUN M134

### 3-11. Disassembly/Assembly

The order of disassembly is in accordance with illustration index number sequence of the referenced illustrations. Assembly is in reverse order of disassembly sequence, unless otherwise indicated.

a. *Housing Cover and Safing Sector (fig. 3-5).*

(1) Remove two release pins (1) securing safing sector (4) to housing assembly (21).

(2) Remove two release pins (3) securing housing cover (2) to housing assembly and housing cover to safing sector; separate housing cover from safing sector.

b. *Removable Tracks and Bolts.*

(1) Rotate barrel cluster in direction shown on housing assembly until a bolt assembly is positioned as shown in figure 3-6. The self-locking nuts securing the removable tracks shall be removed from the rotor studs only if unserviceable.

#### Note

**Rotate firing pin tang to left prior to removal of tracks.**

(2) Remove the six removable tracks and six bolts assemblies as shown in figure 3-6.

c. *Guide Bar (fig. 3-5).* Remove the machine screw (8) securing the rear flange of the guide bar (9) to the housing assembly. Slide the guide bar down and away from the spring pin (10).

#### Note

**The spring pin (10) shall be removed from the housing assembly only if unserviceable. Install replacement pin with the seam facing the barrel end of the gun.**

d. *Barrel Clamp and Barrels (fig. 3-5).*

(1) Remove the barrel clamp bolt (11) from the barrel clamp (12) and remove the barrel clamp.

#### Note

**If barrel clamp is tight around barrels, tap clamp with a soft-faced hammer to loosen.**

(2) Starting with any of the six barrels (13), turn barrel one-half turn to free barrel flange from its slot in the rotor assembly; withdraw barrel from rotor assembly. Repeat to remove remaining five barrels.

(3) If the spline nut in barrel clamp (12) is damaged, replace it as follows:

(a) Remove the spline nut by driving it free from the inside with a punch and hammer.

(b) Install replacement nut by placing washers on bolt (11) until the bolt length is adjusted to grip on thread of the nut. Tighten the bolt to install the nut. Inspect the barrel clamp to verify secure attachment prior to firing the weapon. If the nut becomes loose, staking is permissible.

(4) When assembling the barrels and barrel clamp, observe the following instructions:

#### Note

**When installing gun barrels in barrel clamp, make sure that flat surfaces of barrels contact inside rings of barrel clamp (12). Assembly will be simplified if flat surface of barrel locking flange is parallel with its counterpart.**

(a) Install gun barrels so, that the flat surface of the barrel will contact the inside of ring barrel clamp.

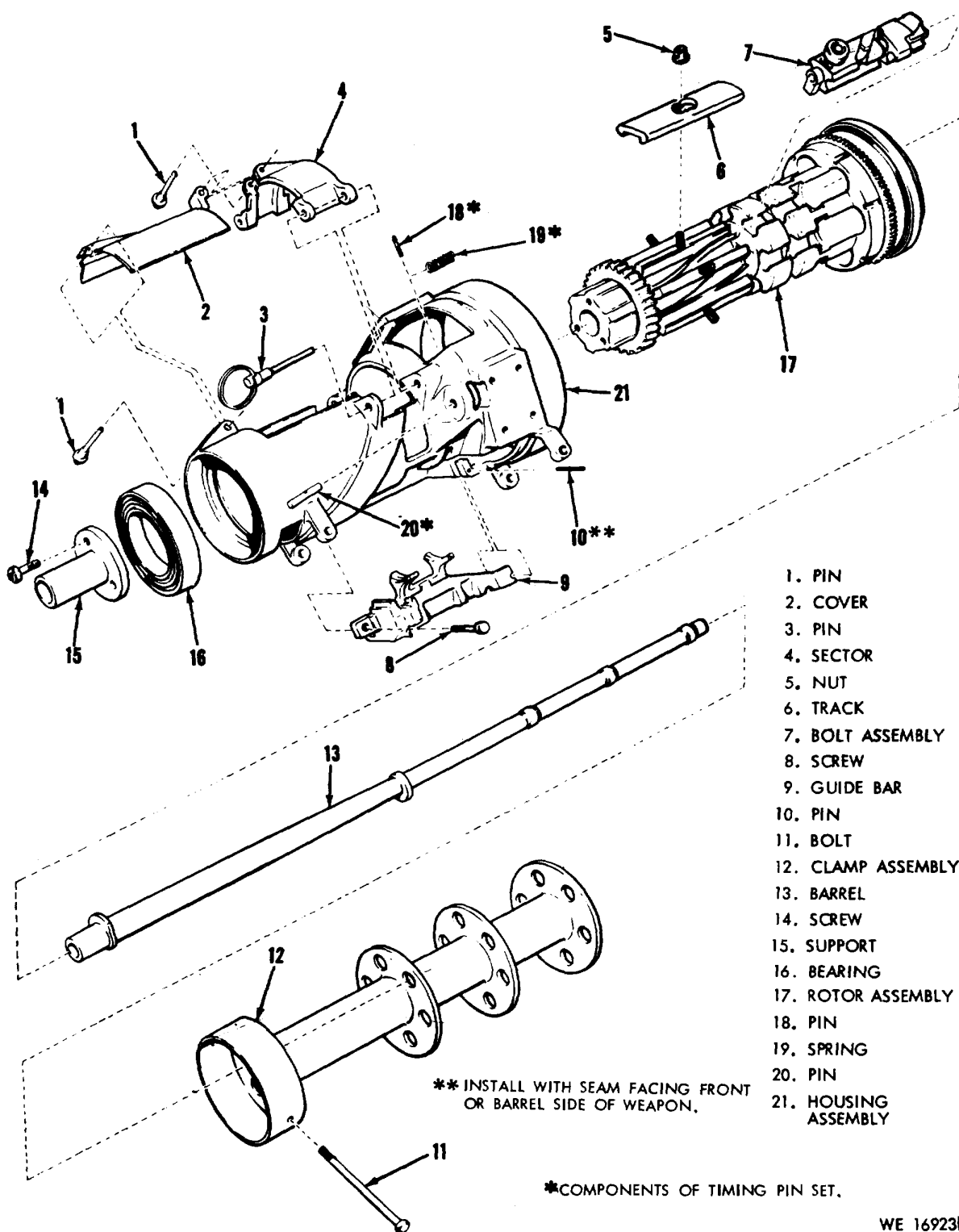

Figure 3-5. 7.62 Millimeter machine gun M14--partially exploded view.

(b) The barrel clamp bolt, which secures the barrel clamp, is tightened until flush with

clamp; then an additional 1/2 turn completes installation.



Figure 3-6. Installation/removal of track bolt assembly.

**Caution:**

**Overtightening can cause bolt to break during operation.**

e. *Rear Support (fig. 3-5).* Remove the three machine screws (14) securing the rear support (15) to the rotor assembly. (16) and remove the rear support as shown in figure 3-7.

f. *Rotor Assembly.* Remove the rotor assembly from the gun housing as shown in figure 3-8; then disassemble the rotor assembly in the order shown in figure 3-9. The following additional procedures are of use in disassembly or assembly.

(1) Place gun housing on a wooden surface, a bench or large block of wood, positioning the housing vertically with the forward end up (fig. 3-10).

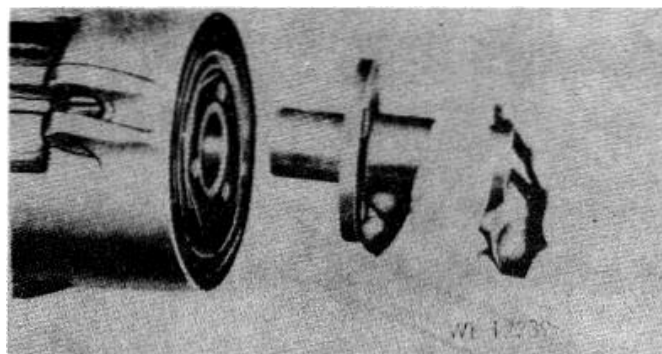

Figure 3-7. Installation/removal of rear support

(2) Place the rotor assembly, bearing first, into the front of the housing assembly until the bearing is positioned securely against the housing assembly.

(3) Place a block of wood against the back of the rotor assembly and strike the block squarely with a hammer to free the bearing.

**Caution:**

**Do not attempt to completely remove the bearing at this time. The bearing can be dislocated only 7/8inch using the housing assembly and additional effort results in damage.**

(4) Position a punch, of sufficient diameter to prevent slipping into the bearing shield, on the inner race of the bearing (fig. 3-11). Trap the punch with a hammer and remove bearing from rotor assembly.

(5) When installing bearing, position the rotor assembly face down on a wooden surface (fig. 3-12). Place the bearing in position on the

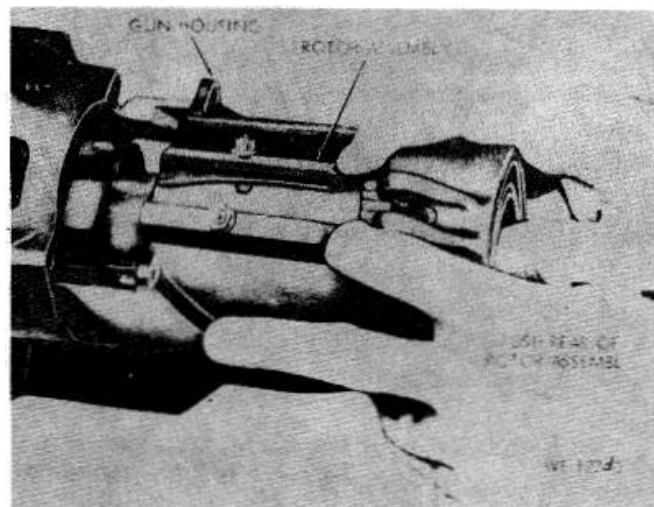
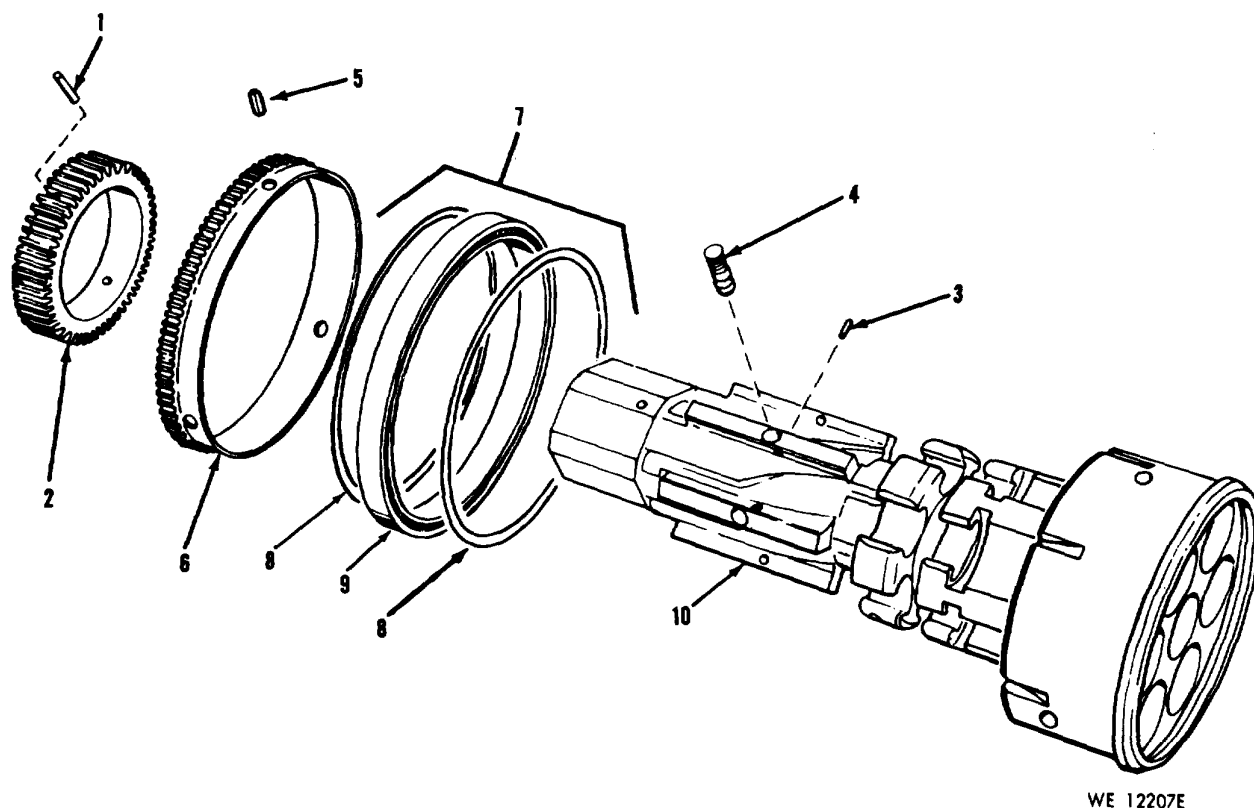

Figure 3-8. Removing rotor assembly from housing.



1-Spring pin  
2-Rear gear -Front gear  
3-Spring pin  
4-Track stud

5-Spring pin  
6-Front gear  
7-Front annular ball bearing  
8-Shield

9-Bearng  
10-Rotor

**Figure 3-9. Rotor assembly-exploded view.**

rotor and use the housing assembly, a wooden block, and a hammer to drive the bearing into position.

(6) During installation of the front gear (6, fig. 3-9) onto the rotor (10), do not drive spring pins (5) inward so far that they interfere during barrel installation.

**Note**

**Install spring pins (3) in track studs (4) with pin seams toward barrel end of rotor. This provides a better fit and prevents loosening of the studs.**

*g. Timing Pin (Not Normally Removed):*

(1) Tap out spring pin (18, fig. 3-5) securing timing -pin (20) in gun housing assembly.

(2) Remove timing pin (20) and helical compression spring (19).

(3) After installation of components is complete, see that the timing pin can be depressed (fig. 2-5) with a barrel at 12 o'clock position.

*h. Bolt Assembly.*

(1) When required, disassemble the bolt assembly as shown tin figure 3-13.

**Caution**

**Exercise care when removing spring pin (5) from spring stop (6) to prevent loss of spring stop. The stop is forcibly ejected by spring tension.**

**Note**

**Do not disassemble bolt subassembly (9). Roller and thrust washer are permanently secured to bolt body.**

(2) When assembling the bolt, install pin (5) with the seam facing the bolt roller. This prevents chafing of the slot in firing pin (8).

**3-12. Cleaning, Inspection, and Repair**

*a. Cleaning.* The gun will be disassembled for cleaning.

**Caution: Do not submerge ball bearings in solvent.**

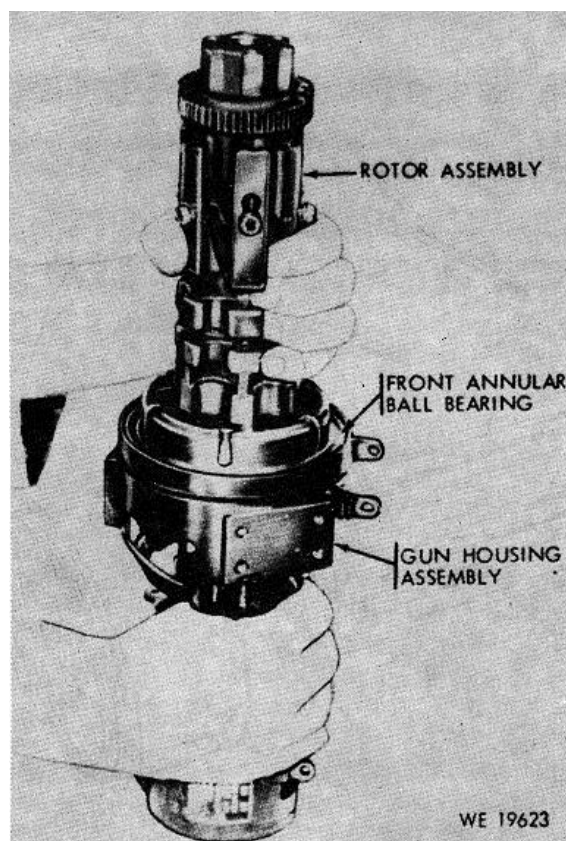

**Figure 3-10. Disengaging bearing from rotor assembly.**

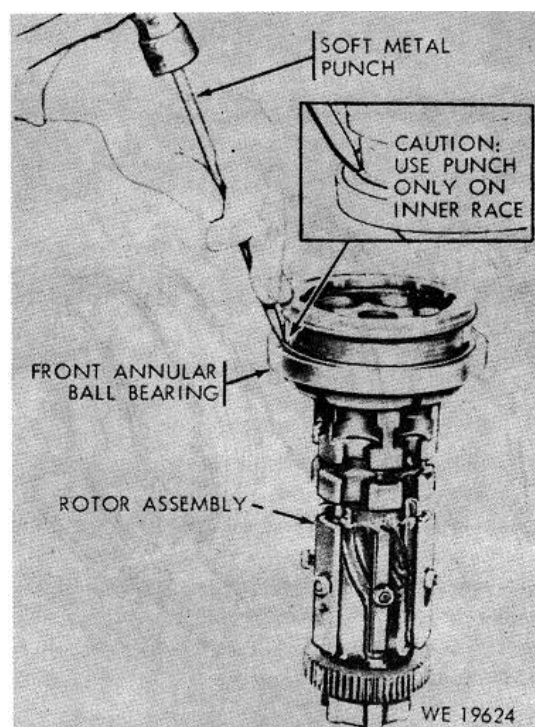

**Figure 3-11. Removing bearing from rotor assembly.**

(1) Special attention will be given to powder-fouled parts such as bolt assemblies and barrels. Immediately after cleaning, parts will be dried thoroughly to remove cleaning solutions or residual moisture.

(2) Immediately after firing, thoroughly clean bore and chamber of each barrel with solvent cleaning compound (CR). Wipe dry and lightly coat with oil PL-S. Every 30 days thereafter, when gun is not being fired, clean with CR, wipe dry, and lightly coat with oil.

(3) After cleaning the barrels, inspect chambers by holding the barrel perpendicular, chamber up, and placing a dummy round, M172, in the chamber. Observe that the cartridge enters the chamber with only the rim and extraction groove protruding. Note that the round is easily removed from the barrel.

(4) If this inspection ((3) above) cannot be

accomplished, clean the chamber again.

**Note**

**If gun cannot be cleaned between missions, coat exterior surfaces of the barrels, barrel clamp, and other parts exposed to the heat of firing with oil PLS, to prevent rusting.**

(5) Wipe ball bearings clean with a suitable solvent in lieu of CR.

*b. Inspection.* Specific points for inspection are listed in table 3-7.

*c. Repair.* Burrs will be removed and the part used whenever possible. Pits or chip marks should be stoned and if part functions properly, it should be retained in service. If pitting, chipping, or Brinell marks are severe, the item will be discarded. Cracked parts will be discarded and new parts installed where authorized. If parts are not authorized, replace with next higher assembly that is authorized.

**Table 3-7. Machine Gun Inspection Points**

Component	Figure and item	Inspect for
Housing cover	3-5-2	1. Distortion, cracks, and bends. 2. Deformation of slot in end of housing cover.
Safing sector	3-5-4	1. Nicks, cracks, or breaks. 2. Camming surfaces which do not align with gun housing.

**Table 3-7. Machine Gun Inspection Points-Continued**

Component	Figure and Item	Inspect for
Removable bolt tracks	3-5-6	1. Cracks, breaks, and distortion.
Bolt assemblies	3-3-4	1. Worn or elongated firing pin hole, damaged or broken extractor lip, and worn or burred pins and locking surfaces on bolt head.
	3-13-4	2. Nicks, burrs, and signs of galling in track ways.
	3-13-9	
	8-13-7	3. Cracks, breaks, and loss of tension in spring (free length must be no less than 1.67 inches).
	3-13-8	4. Worn or broken striker, burrs, and worn tang on firing pin.
	3-13-9	5. Worn or damaged roller on bolt subassembly.
	3-13-2	6. Worn, bent, or upset spring pins.
3-13-3		
3-13-5		
Guide bar	3-5-9	1. Nicks, burrs, cracks or bends. 2. Proper control of rounds by rim guide.
Rear support	3-5-15	1. Breaks, dents, galling, or cracks in tubular walls. 2. Warped face.
Barrel clamp assembly	3-5-12	1. Worn, stripped, or damaged threads in spline nut 2. Distribution, cracks, and breaks in barrel rings or central shaft.
Barrels	3-5-13	1. Cracks, breaks, or burrs on barrel flange. 2. Pitting, scoring, excessive wear of lands, and bulges in barrel bore.
Rotor assembly	3-9-2, -6	1. Cracked, broken, or chipped teeth on front and rear gears.
	3-9-7	2. Free rotation of ball bearing.
		3. Nicks, burrs, and signs of galling in bolt tracks of rotor.
		4. Wear on triggering cam surfaces of rotor.
Bearing	3-5-16	Free rotation.
Timing pin	3-5-20	Bent or broken components.
Gun housing assembly	3-5-21	Nicks, burrs, abnormal rubbing, or wear of camming surfaces.

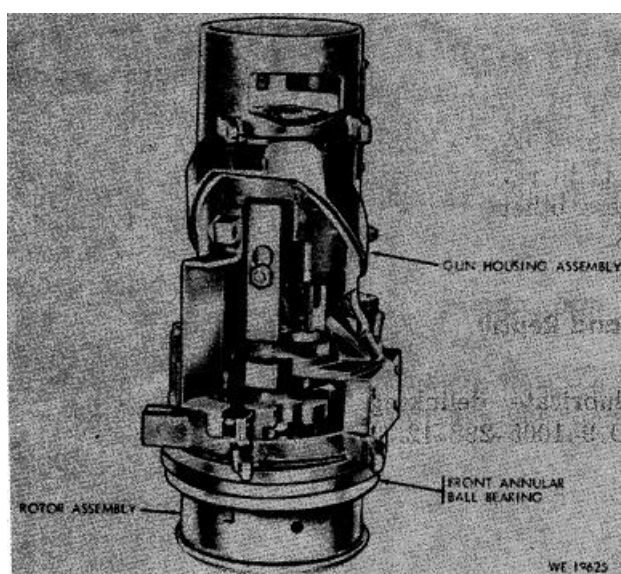

**Figure 3-12. Installing bearing on rotor assembly.**

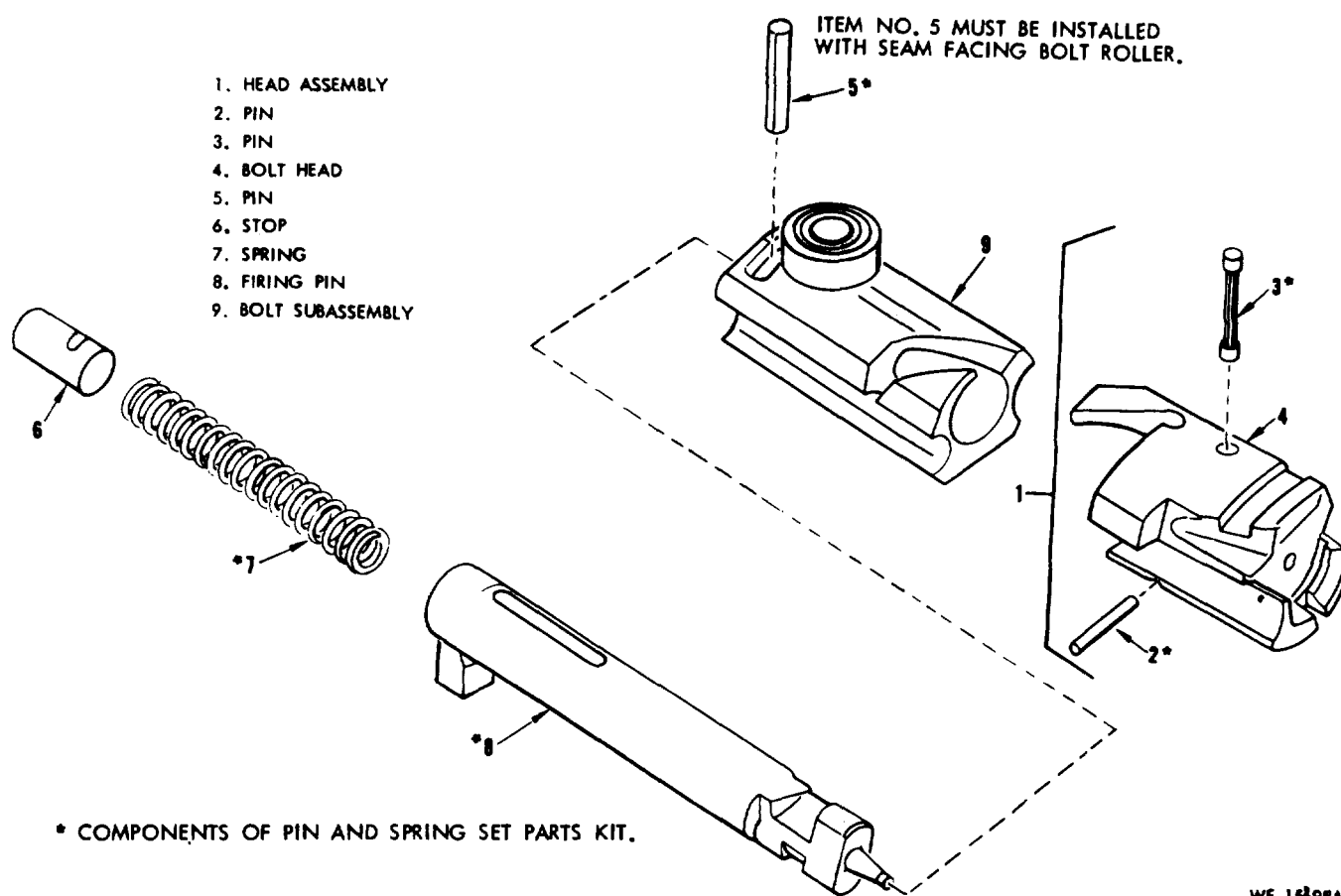

Figure 313. Bolt assembly-exploded view.

Section VIII. MAINTENANCE OF DELINKING FEEDER MAU-56/A

3-13. Disassembly/Assembly (fig. 3-14)

The order of disassembly is in accordance with illustration index number sequence of the referenced illustrations. Assembly is in reverse order of disassembly sequence, unless otherwise indicated.

3-14. Cleaning, Inspection, and Repair

a. *Cleaning.* Clean and lubricate delinking feeder in accordance with LO 9-1005-298-12.

**Caution:**

Do not allow cleaning solvent to

enter gun feed solenoid, gun cleared sensor, or sealed bearings.

b. *Inspection.* Inspect delinking feeder drive gear (fig. 3-14) for chipped or broken teeth, drive pins (14 and 15) bent or sheared, excessive wear of push rod (9) or roller (8), damaged bearings, and feed solenoid linkage for excessive wear.

c. *Repair.* Repairs are limited to replacement of parts available at organizational level; refer to TM 9-109-698-20P.

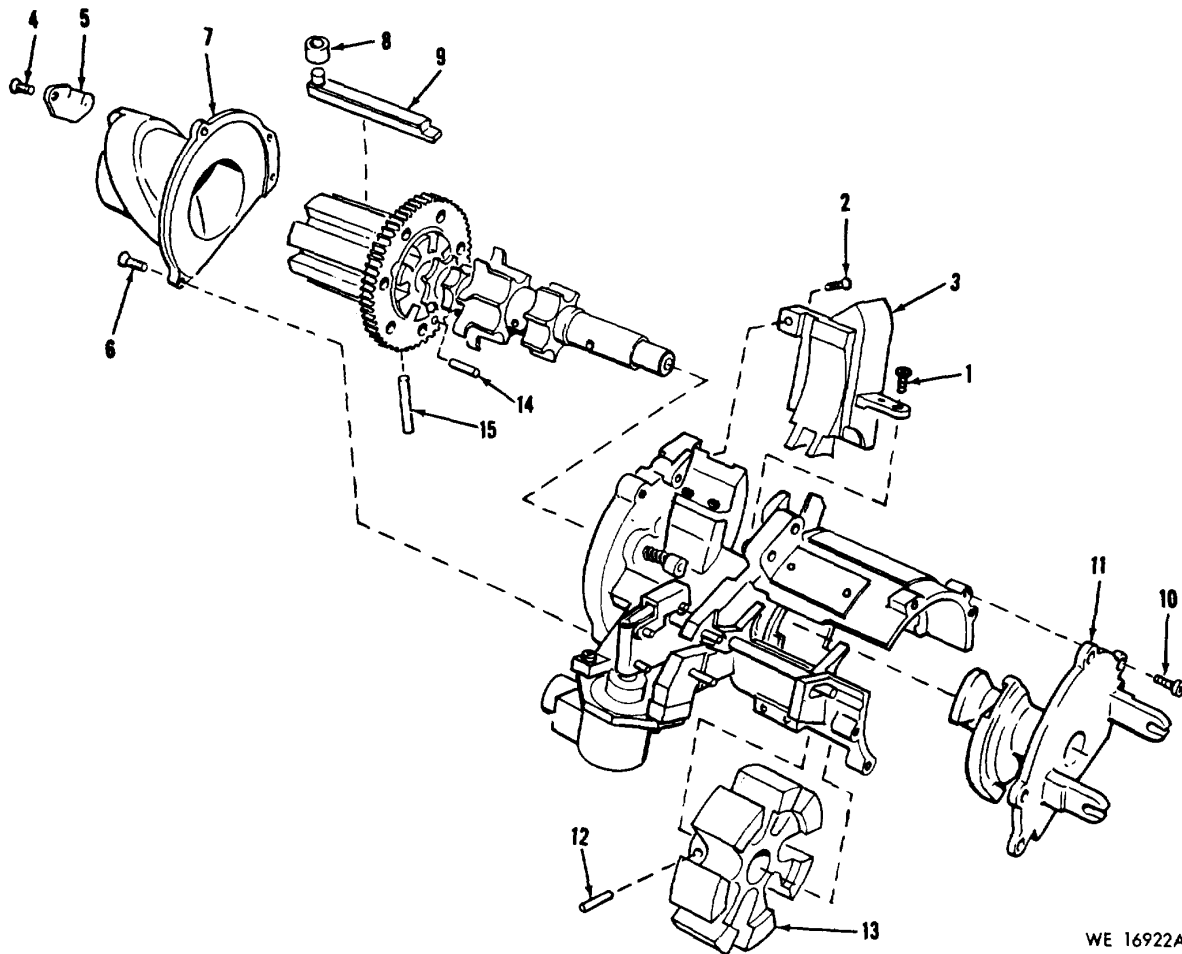

WE 16922A

1-Screw  
2-Screw  
3-Guide  
4-Scrcw  
5-Insert

6-Screw  
7-Housing  
8-Roller  
9-Push rod  
10-Screw

11-Plate  
12-Pin  
13-Sprcket  
14-Pin  
15-Pin

Figure 5-14. Delinking feeder MA U-56/A-partially exploded view.

Section IX. MAINTENANCE OF GUN ELECTRIC DRIVE ASSEMBLY

3-15. Disassembly/Assembly (fig. 3-15)

a. Remove safetywire, screws, and washers attaching gun drive control assembly to motor.

b. Disconnect electrical wires from motor to gun drive control assembly.

**Note**

When installing a replacement gun drive control assembly be sure to connect colored wires from motor to appropriately marked studs. Observe torque requirements shown in figure 3-15. Lock-ire screws.

a. Clean and lubricate drive gear in accordance with LO 9-1005-298-12.

**Caution:**

Do not allow cleaning solvent to enter the motor, gun drive control assembly, or electrical connectors.

b. Inspect drive gear for chipped or broken teeth, and gun drive control assembly housing for external damage.

c. Paint surfaces in accordance with TM 9213.

d. Repairs are limited to replacement of parts available at organizational level. Refer to TM 9-1005-298-20P.

3-16. Cleaning, Inspection, and Repair



**NOTES:**

1. TORQUE TO 15-18 FT-LBS
2. TORQUE TO 65-70 IN-LBS
3. TORQUE TO 22-25 IN-LBS

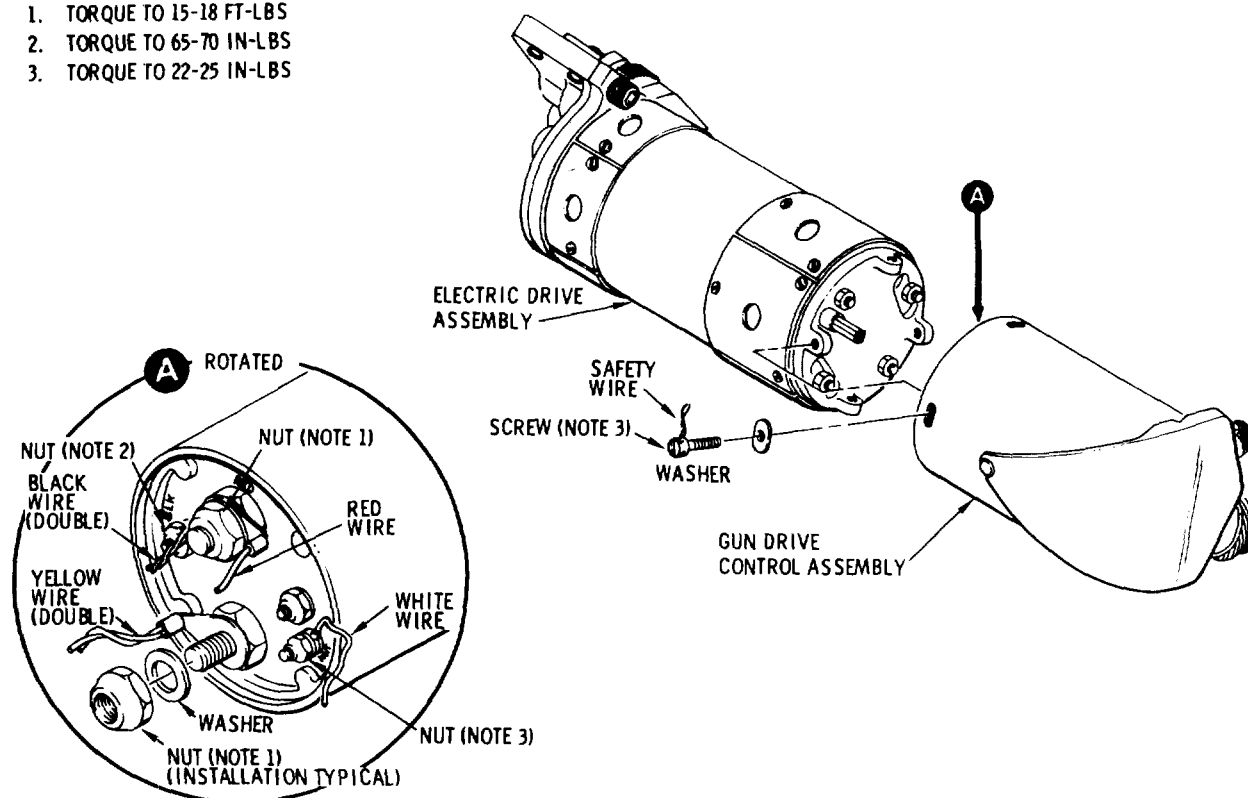

Figure 3-15. Gun electric drive assembly-partially exploded view.

WE 15630A

**Section X. MAINTENANCE OF FAIRING ASSEMBLY**

**3-17. Removal/Installation**

Refer to paragraph 2-6.

**3-18. Disassembly/Assembly**

See figure 3-16.

**3-19. Cleaning, Inspection, and Repair**

a. *Cleaning.* None required.

b. *Inspection.* Inspect for cracks, tears, and missing fasteners. Inspect ram air duct for obstructions.

c. *Repair.* Repairs are limited to replacement of parts available at organizational level. Refer to TM 9-1005-298-20P.

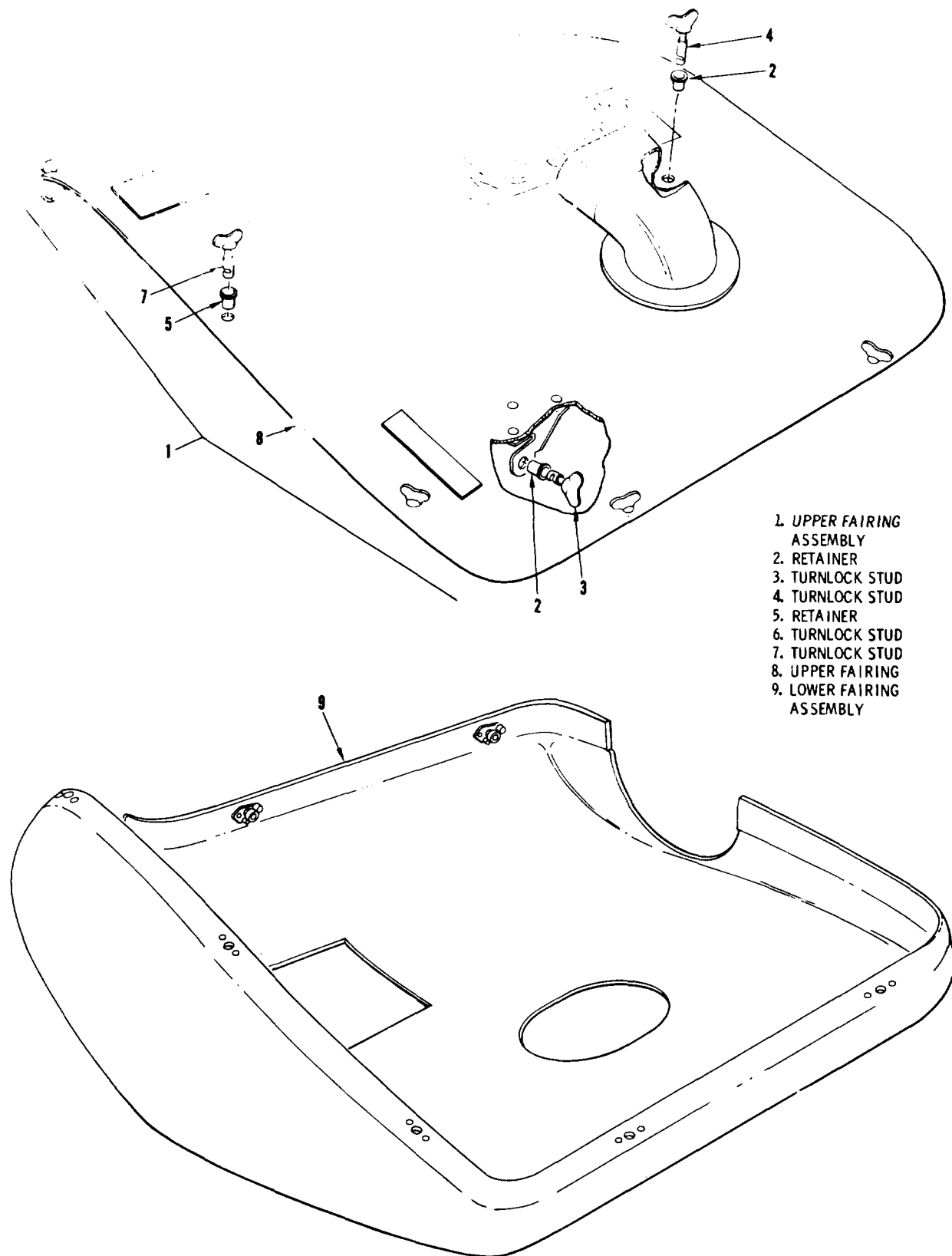

- 1. UPPER FAIRING ASSEMBLY
- 2. RETAINER
- 3. TURNLOCK STUD
- 4. TURNLOCK STUD
- 5. RETAINER
- 6. TURNLOCK STUD
- 7. TURNLOCK STUD
- 8. UPPER FAIRING
- 9. LOWER FAIRING ASSEMBLY

Figure 3-16. Fairing assembly-partially exploded view.

WE 15661A

## Section XI. MAINTENANCE OF MOUNT ASSEMBLY

**3-20. Removal/Installation**

Refer to paragraph 2-2.

**3-21. Disassembly/Assembly**

See figures 3-17 through 3-21. The order of disassembly is in accordance with illustration index number sequence of the referenced illustrations. Assembly is in reverse order of disassembly sequence, unless otherwise indicated.

*a. Ammunition Container Assembly (fig. 317).*

(1) Unlatch the two latches on the sides and near the inboard end of the container assembly.

(2) Lift the inboard end of the container assembly slightly to disengage locator block then slide the container assembly inboard until pins retaining the lower outboard end are clear.

(3) Remove the ammunition container assembly.

(4) Disassemble ammunition container assembly in the sequence shown in figure 3-18.

*b. Electrical System Assembly (fig. 3-19).*

(1) Remove cover from control box assembly.

(2) Disconnect elevation motor wire terminals from terminal block using extraction tools, from Supplemental Tool Set MOS 45J. The wires are TB1-Fn (white wire), TB1-Ep blue wire, TB1-Fp (red wire), and TB1-A19 (green wire).

(a) Slip extraction tool over wire; then, push tool into the terminal block socket cavity until contact retaining clip is compressed.

(b) Pull tool and wire, with contact, out of terminal block.

**Note**

**To insert, slip insertion tool over wire and contract retaining clip, then, push tool and contact into socket cavity. Hold wire while withdrawing tool.**

(3) Loosen clamp and pull disconnected wires through the grommet and out of the control box assembly.

(4) Disconnect all electrical plugs from control box receptacles.

(5) Remove screws attaching the control box assembly to the mount assembly and remove control box assembly.

(6) Disconnect gun drive cable assembly from gun electric drive assembly.

(7) Remove clamp securing cable assembly to housing and tube assembly.

(8) Remove ammunition feed chute assembly and adapter chute as outlined in paragraph 3-21c (2).

(9) Remove gun drive cable assembly from torque tube.

*c. Housing and Tube Assembly.* Disassemble the housing and tube assembly as shown in figure 3-20 and in accordance with the following:

(1) *Elevation motor and sensor assembly (fig. 3-19 and 3-20).*

(a) Remove cover assembly from the control box assembly, disconnect elevation motor wire terminals from terminal blocks, and remove wires from control box (para 3-21b).

(b) Remove clamp (8, figure 3-20) to free elevation motor wires.

(c) Use a 1/8-inch punch to drive out spring pin (10) which retains the elevation motor in the mount assembly casting.

(d) Remove motor and sensor assembly (11) with key (12).

*Note* Disassembly of motor and sensor assembly is not authorized at the organizational maintenance level.

(2) *Ammunition chutes (fig. 3-20).*

(a) Remove feed chute (20) by pulling outward through gun torque tube.

(b) Remove adapter chute (19) by removing attaching screws (13).

(c) Disassemble adapter chute as shown in figure 3-20.

**Note**

**At assembly, install cotter pin (15) as shown.**

*d. Door Filler Assembly (fig. 3-17).* The door filler assembly is normally installed in the aircraft left cargo door and requires no disassembly at the organizational level of maintenance.

*e. Control Pod Assembly.* Disassemble or assemble the control rod assembly as shown in figure 3-21.

**Note**

**Replacement of control rod assembly or rod ends makes boresighting necessary (para 2-12).**

**3-22. Cleaning, Inspection, and Repair****Caution:**

**Do not allow solvent to enter electrical connectors, control box, or elevation motor.**

*a. Cleaning.* Clean mount assembly components by wiping with a cloth moistened with dry cleaning solvent (SD). Lubricate in accordance with LO 9-1005-298-12.

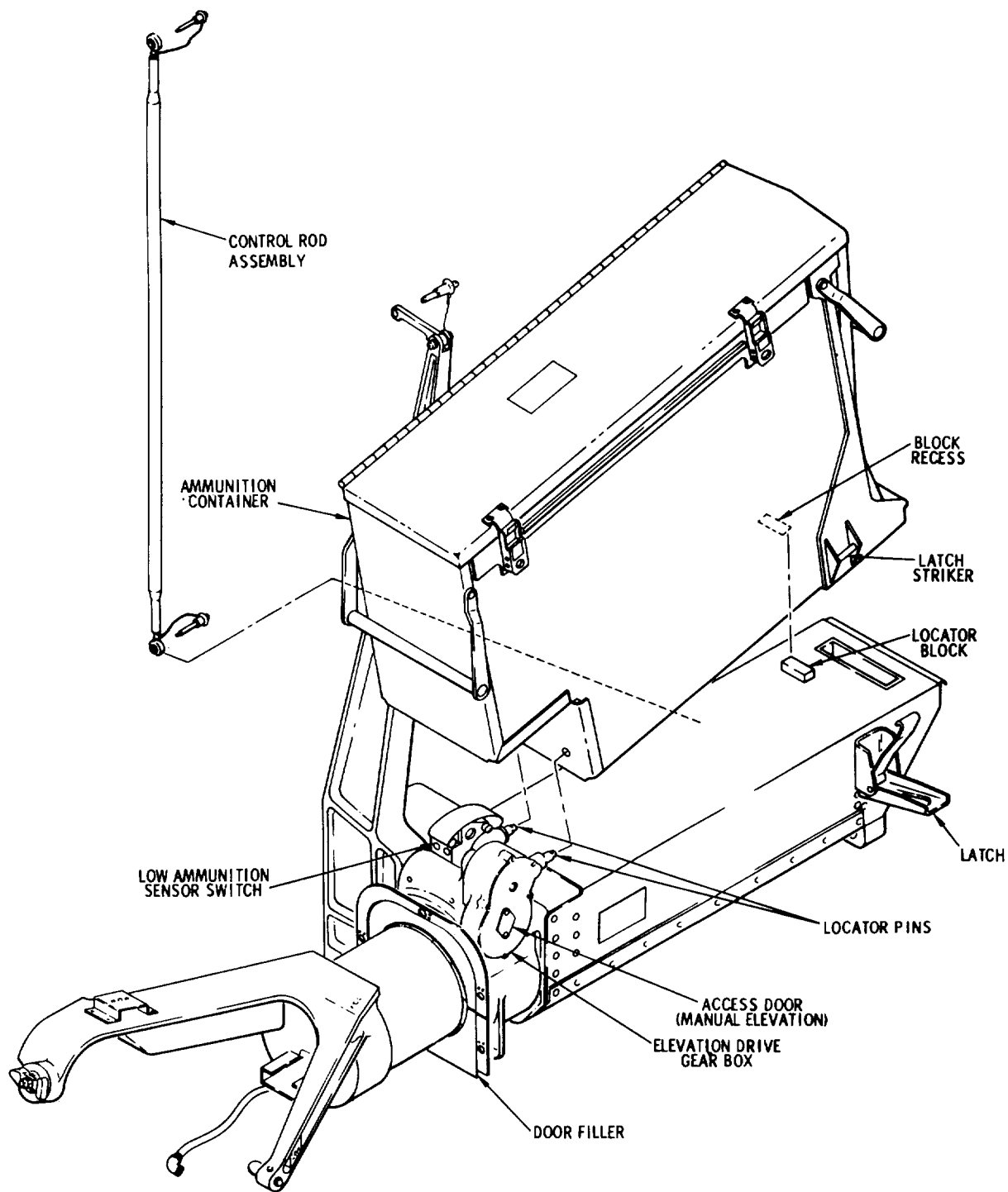

WE15656A

Figure 3-17. Mount assembly-partially exploded view.

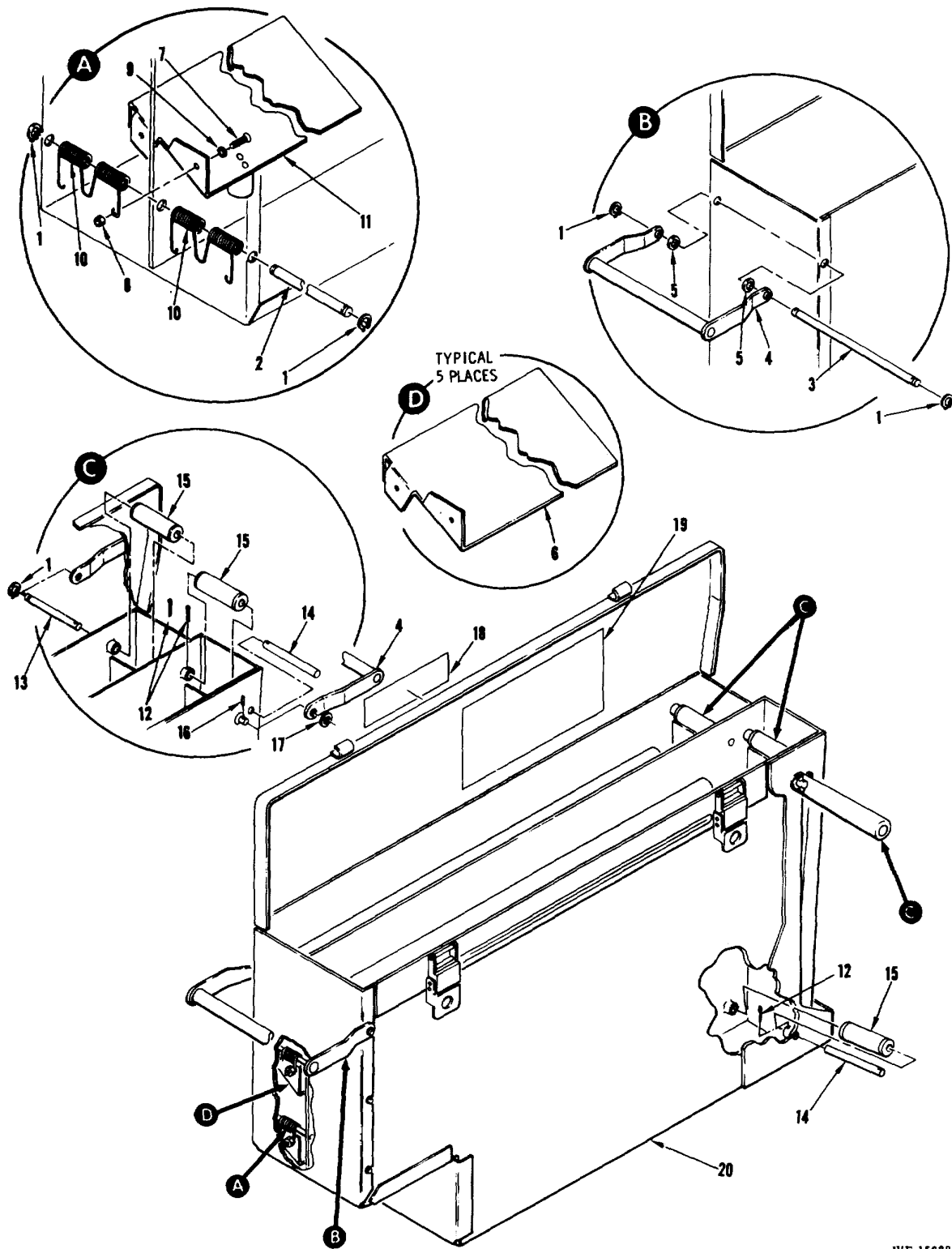

1-Retaining ring  
 2-Grooved pin  
 3-Grooved pin

4-Handle  
 5-Washer  
 6-Leveler

7-Screw  
 8-Nut  
 9-Washer

Figure 3-18. Ammunition container assembly-partially exploded view.

10-Spring  
 11-Leveler assembly, ammo sensor  
 12-Cotter pin  
 13-Grooved pin

14-Straight pin  
 15-Roller assembly  
 16-spring pin  
 17-Washer

18-Caution decal  
 19-Loading decal  
 20-Ammunition container structure

**Figure 3-18 Continued**

b. *Inspection.* Refer to table 3-8.

c. *Repair.*

(1) Repairs to the housing and tube assembly are limited to replacement of authorized parts such as the ammunition chutes, mounting pins and lanyards, gun side mount lock parts, and shock isolator.

(2) Replace door filler assembly if damage prevents use.

(3) Repair ammunition container assembly by

straightening dents and replacing damaged components such as leveler assemblies, springs, pins and rollers.

(4) No repairs to the elevation motor sensor assembly, the gun drive cable assembly, or to the control box assembly are authorized.

(5) Repair control rod assembly by replacing damaged components such as rod ends, release pins, and tube.

**Table 3-8. Mount Assembly Inspection Points**

Component	Figure and item	Inspect for
Housing and tube assembly	3-20	Dents, cracked castings, loose or missing rivets, bearing looseness or binding, bent mounting pins, and damaged gun mount shock isolator or lock.
Door filler assembly	8-17	Cracks, tears, and missing fasteners.
Ammunition container assembly	3-18	Dents, cracks, broken levelers or springs, rollers excessively loose or binding and broken latches.
Ammunition chutes	3-20-19	Cracks, dents that could restrict ammunition flow, and roller excessively loose or binding.
Control box assembly	3-19	Damaged electrical receptacles and dents which could cause damage to internal components.
Gun drive cable assembly	3-19	Damaged electrical plugs, chaffed insulation or damaged wires.
Elevation motor and sensor assembly	3-20-11	Damaged sensor switch or actuator and damaged wiring.

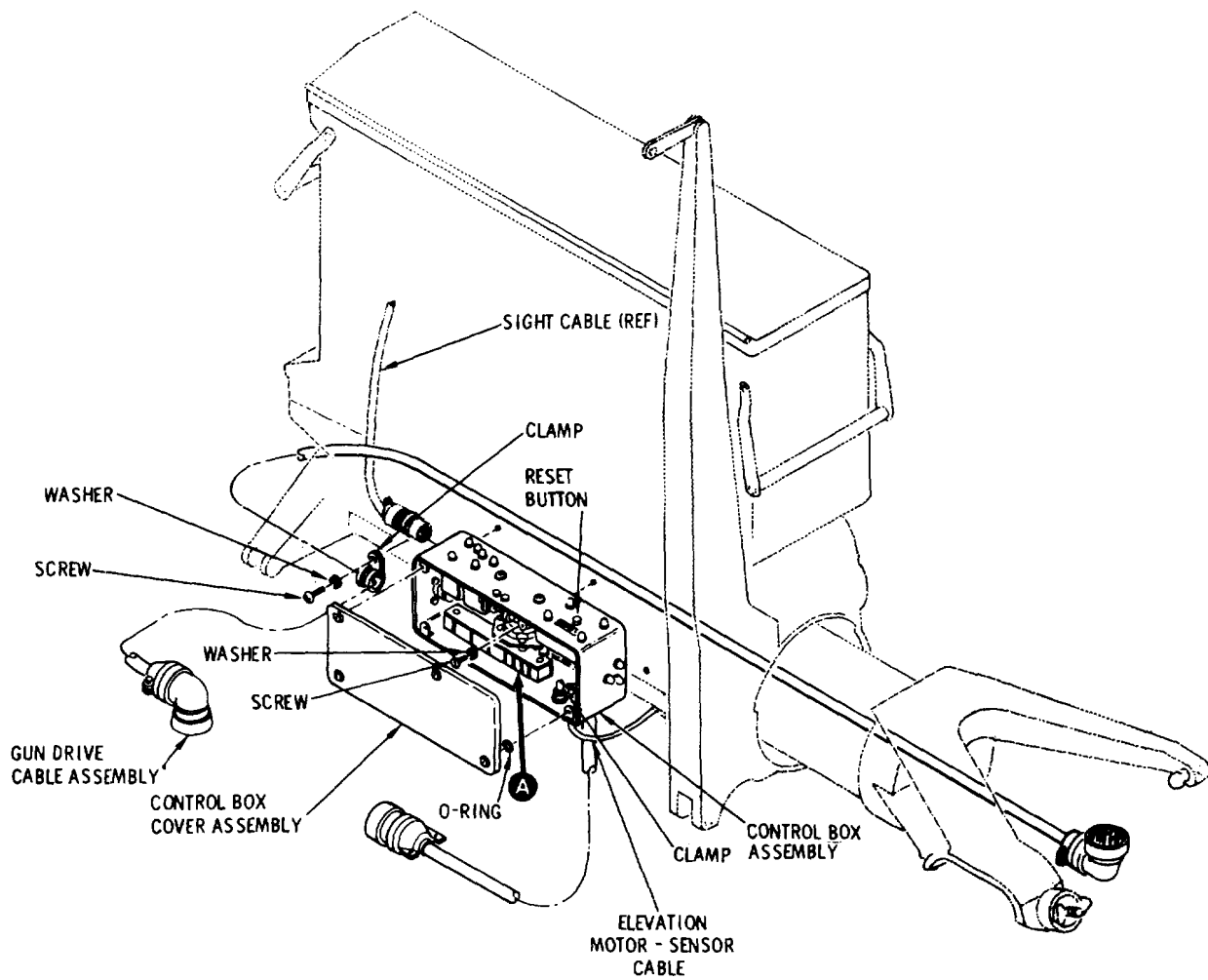
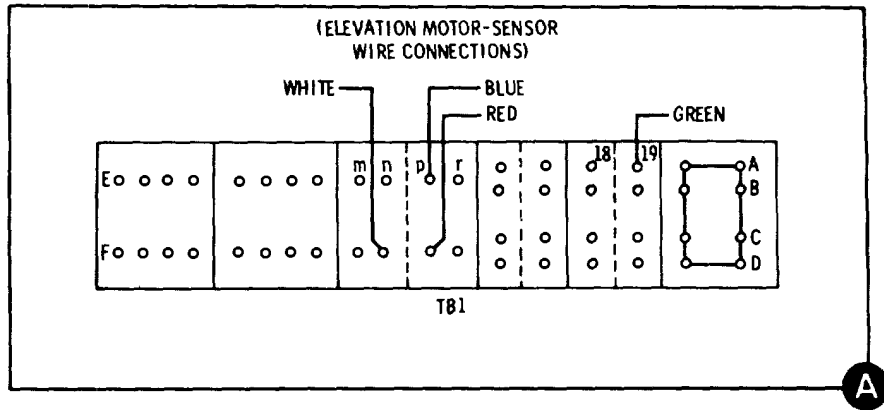

WE 15657A

Figure 3-19. Electrical system assembly-partially exploded view.

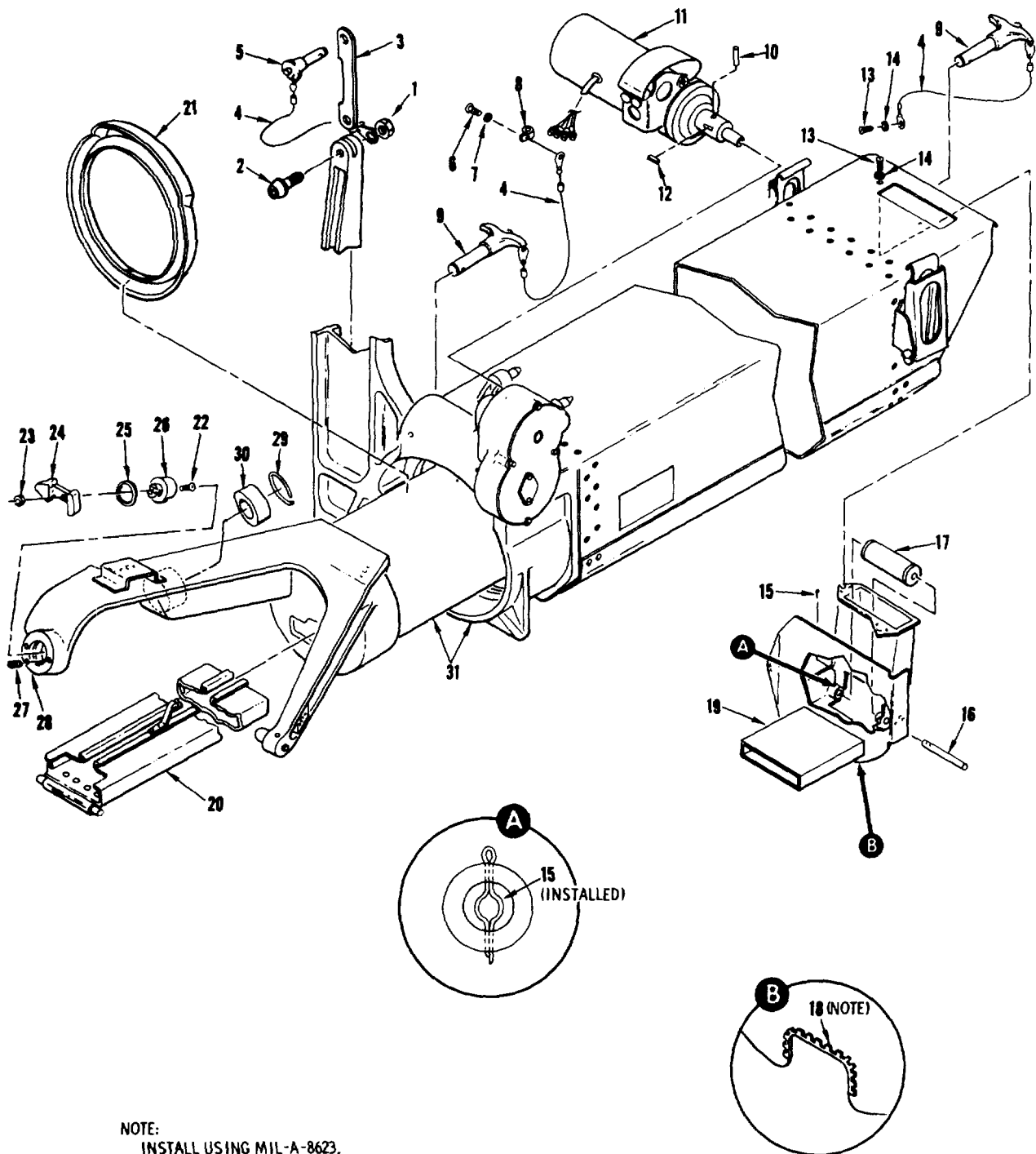

NOTE:  
INSTALL USING MIL-A-8623,  
TYPE I ADHESIVE.

1-Nut  
2-Bolt  
3-Link

4-Lanyard  
5-Release pin  
6-Screw

7-Washer  
8-Clamp  
9-Release pin

WE15650A

Figure 3-20. Housing and tube assembly-partially exploded view.



- |                     |                          |                              |
|---------------------|--------------------------|------------------------------|
| 10-Spring pin       | 18-Grommet               | 26-Cam                       |
| 11-Motor and sensor | 19-Adapter chute         | 27-Spring                    |
| 12-Key              | 20-Ammunition feed chute | 28-Ball                      |
| 13-Screw            | 21-Dust seal             | 29-Retainer                  |
| 14-Washer           | 22-Screw                 | 30-Shock isolator            |
| 15-Cotter pin       | 23-Nut                   | 31-Housing and tube assembly |
| 18-Roller pin       | 24-Lock handle           |                              |
| 17-Roller           | 25-Retainer              |                              |

Figure 3 -20 Continued

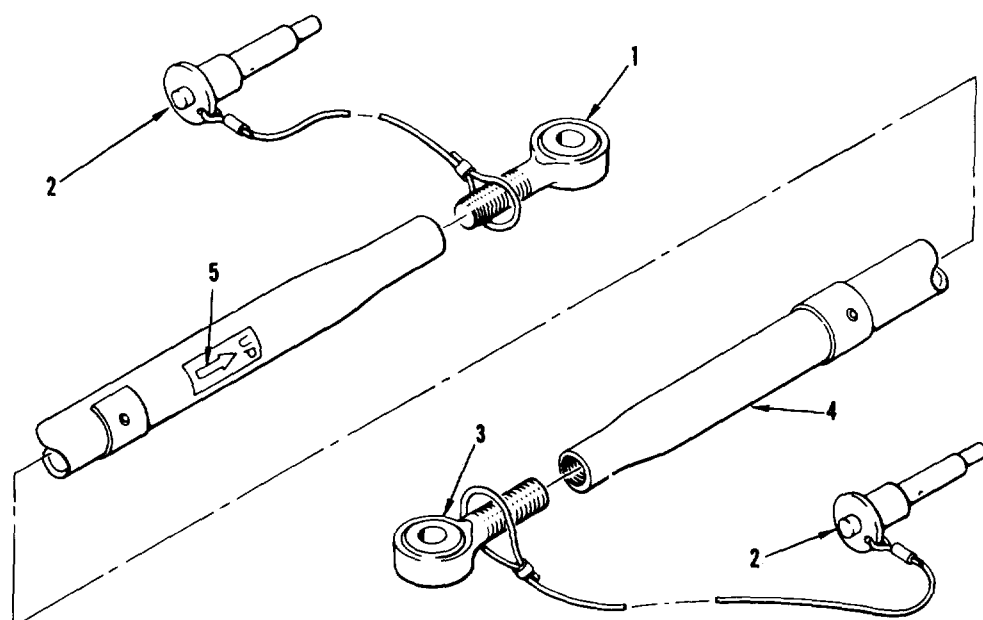

1. ROD END (R/H THREAD)
2. RELEASE PIN
3. ROD END (L/H THREAD)
4. TUBE ASSEMBLY
5. DECAL

WE 15665A

Figure 3-21. Control rod assembly-partially exploded view.

## Section XII. MAINTENANCE OF HELICOPTER REFLEX SIGHT XM70E1

### 3-23. Removal/Installation of Reflex Sight Assembly

Refer to paragraph 2-3.

### 3-24. Disassembly/Assembly (fig. 3-22)

Complete disassembly is not authorized at organizational level maintenance. Disassembly and assembly at organizational level is primarily for replacement of the following components, when defective.

a. *Beamsplitter.* The beamsplitter is replaced by loosening the single attaching screw at the end of the arm. A spare beamsplitter is included in the sight carrying case.

b. *Lamp.* The projector lamp is replaced by loosening three captive screws attaching the upper housing to the projector. Hold housing aside while replacing the bulb. Reinstall upper housing.

**Note. The frosted side of the bulb is to face the projector reticle.**

### 3-25. Cleaning, Inspection, and Repair

a. *Cleaning.* Clean and apply a light thin film of instrument lubrication oil to mounting surfaces, bare metal operating components, bearings, etc. Clean optical surfaces with lens tissue.

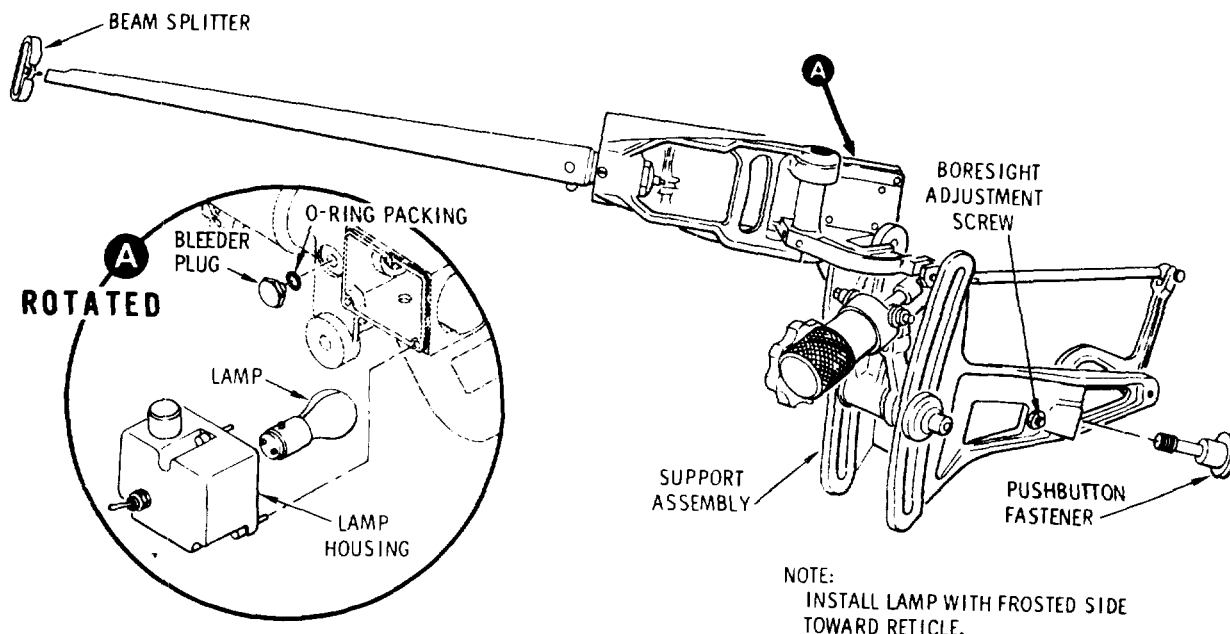

WE 15627A

**Figure 3-22. Reflex sight XM70E1--partially exploded view.**

*b. Inspection.* Check all items for damage, distortion, or other defects. Check electrical components for proper operation (para 2-11).

*c. Repair.* Repair primarily consists of replacement of parts listed in paragraph 3-24. Additionally, the projector assembly is purged whenever the internal optical elements are exposed to air. Purging procedures are outlined in paragraph 3-26.

**3-26. Purging of Projector Assembly (fig. 3-23)**

*a. Setup.*

(1) Obtain a tank of dry technical nitrogen (item 2, table 3-2) and remove the threaded protective cover from outlet of the tank. Open valve momentarily to rid valve seat of any foreign matter.

(2) Check nitrogen filling adapter for cleanliness and proper seating of gasket. Securely attach adapter (item 1) to tank valve and then secure regulator (item 1) to adapter.

(3) Remove can from low pressure port of regulator, and securely attach hose assembly to the same port.

(4) Rotate pressure regulator valve counterclockwise to the extreme closed position.

(5) Open the nitrogen tank valve slowly until pressure is registered on the high pressure gage.

**Note.** If pressure is less than 100 psi, obtain and use replacement tank.

(6) Slowly rotate pressure regulator valve clockwise until approximately 5 psi is registered on the low pressure gage. Close pressure regulator valve.

(7) Remove plug and packing from projector. Install purging adapter (item 3) in projector housing.

(8) Securely attach free end of hose assembly (item 1) to purging adapter.

*b. Purging.*

(1) Open pressure regulator valve until 5 psi is registered on the low-pressure gage. Allow this pressure to flush through the instrument for five minutes. Check that nitrogen is being forced out through bleed hole adjacent to the adapter fitting.

(2) Reduce regulator pressure to between 0.5 to 1 psi.

(3) Temporarily block the bleed hole in projector housing using a suitable plug.

(4) Open pressure regulator valve until 5 psi is registered on the low pressure gage and apply this pressure to the instrument for five minutes. Check for any nitrogen leakage from the instrument.

(5) Close regulator and nitrogen tank valves.

(6) Remove hose assembly from purging adapter.

(7) Remove purging adapter (item 3) and bleed hole plug from projector. Install preformed packing and plug.

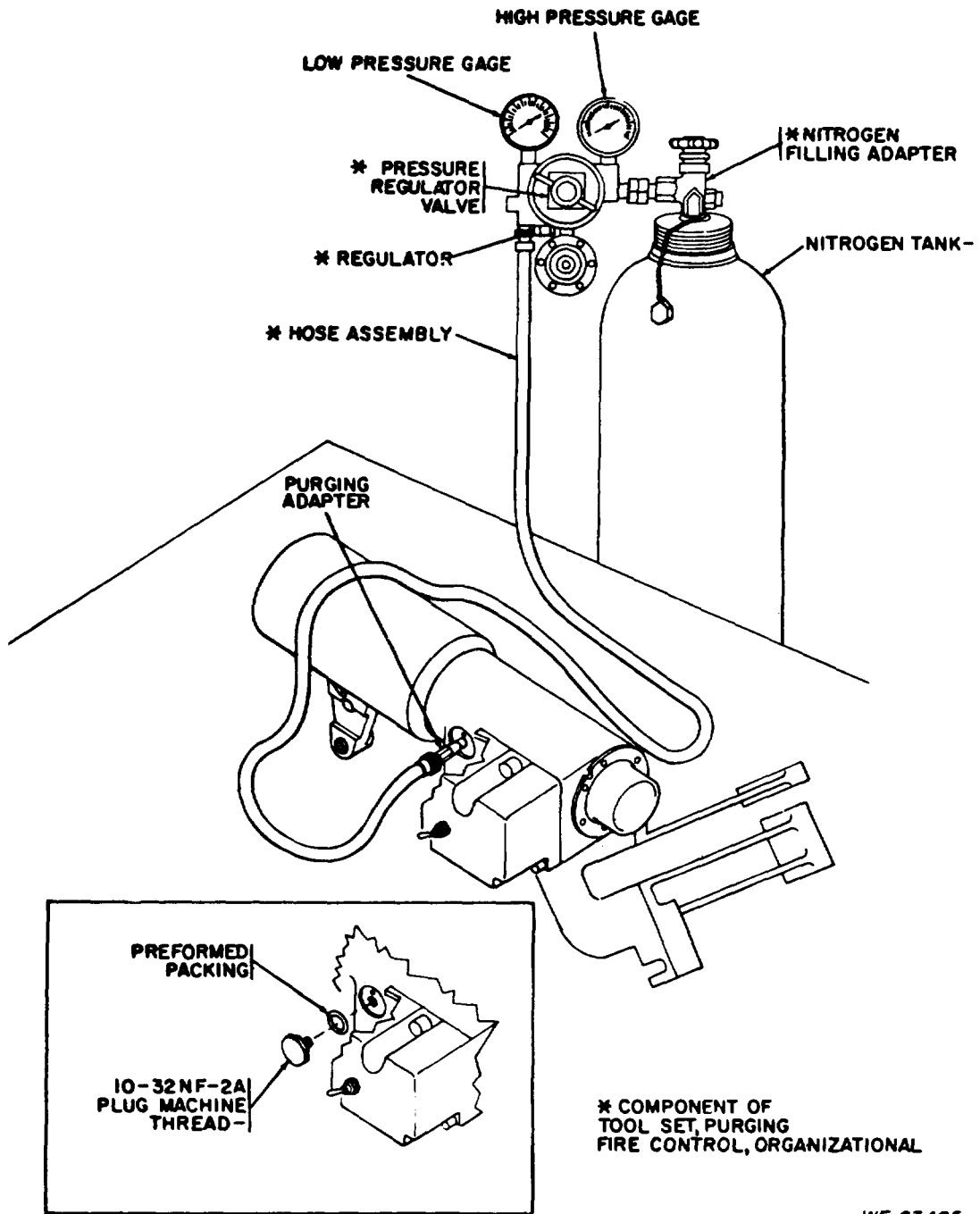

WE 23485

Figure 3-23. Equipment setup for purging projector assembly.

CHAPTER 4

AMMUNITION

Section I. GENERAL

**4-1. Scope** This chapter contains information on the 7.62 millimeter ammunition used in firing the machine gun M134.

**4-2. General** The 7.62 millimeter cartridge is a standard NATO size. It is designed for interchangeable use in the

rifle M14, machine guns M60 and M134 and in rifles and machine guns adopted by other NATO countries.

Section II. CLASSIFICATION

**4-3. Types**

The 7.62 millimeter ammunition authorized for use in the machine gun M134 and armament subsystem is of four distinct types (fig. 4-1).

**4-4. Tabulated Data**

Refer to table 4-1 for a tabular listing of 7.62 millimeter ammunition weights, dimensions, and ballistic data.

**Warning:** The cores of any 7.62 millimeter bullets which fail to penetrate may ricochet up to 100 yards.

a. *7.62 millimeter AP cartridge M61 (NATO).* The cartridge is intended for use against light armored or other bullet-resisting targets.

b. *7.62 millimeter ball cartridge M59 (NATO) and 7.62 millimeter ball cartridge M80 (NA TO).*

c. *7.62 millimeter tracer cartridge M62 (NATO).* The cartridge is intended for use primarily as visual means of observing the trajectories and points of target impact of other service type cartridges. It is also used as a means of signaling and is effective against unarmored targets and personnel.

d. *7.62 millimeter dummy cartridge M175 (Inert Loaded).* The cartridge is intended for use in training personnel in the loading and unloading procedures and in the operation and maintenance of weapons or weapon systems which use 7.62 millimeter ammunition.

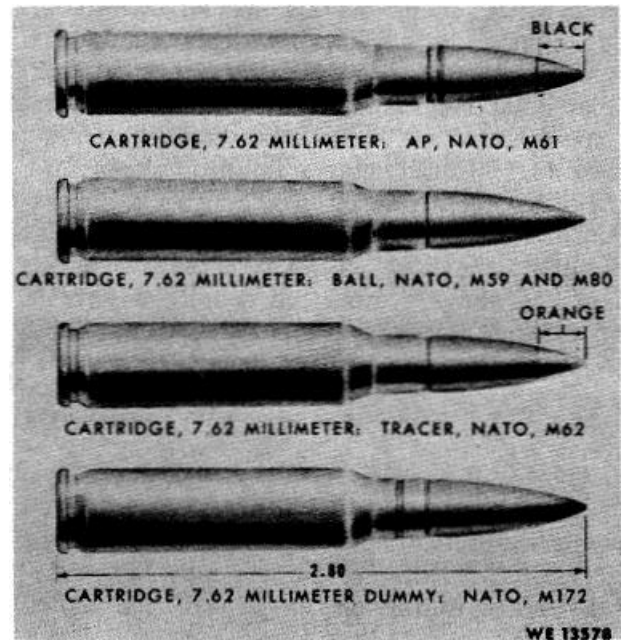

Figure 4-1. 7.62 Millimeter NATO cartridges.

Table 4-1. 7.62 Millimeter Ammunition Weights Dimensions, and Ballistic Data.

	Ball, M59	Ball, M80		Tracer, M62		AP. M61)	Dummy M1 72 (insert loaded)	
	G.M.	G.M.	G.M.C.S	G.M.	G.M.C.S.	G.M.	G.M	G.M.C.S.
Velocity (f/s)								
Muzzle .....	2809	2809	2809	2731	2804	N.R.	.....	.....
24 meters (78 ft) .....	2750	2750	2750	2680	2750	2750	.....	.....

Table 4-1. 7.62 Millimeter Ammunition Weights, Dimensions, and Ballistic Data-Continued.

	Ball M59	Ball M80		Tracer, M62		AP, M61	Dummy, M172 (Insert loaded)	
	G.M.	G.M.	G.M.C.S.	G.M.	G.M.C.S.	G.M.	G.M.	G.M.C.S.
550 meters (600 yds).....	1619	1614	1614	1681	1696	N.R.		
Maximum range								
Meters .....	3820	3930	3930	2340	2340	3820		
Yards .....	4180	4300	4300	2560	2560	4180		
Accuracy (mean radius in inches) measured at 550 meters (600 yds)								
Machine gun .....	7.5	7.5	7.5	15.0	15.0	7.5		
Rifle .....	7.5	5.0	516	16.0	15.0	7.5		
Drop in inches at 550 meters (600 yds)	116	116	116	117	112	N.R.		
Cartridge weight (gr).....	393	392	392	387	382	393	885	385
Bullet weight (gr).....	150	149	149	146	141	150	149	149
Propellant weight (gr)								
WC 846.....	46	46	46	46	46	46		
IMR 4475.....	41	41	41			41		
IMR 8138M .....		41.5	41.5					
Inert mix .....							46	46
Cartridge length (in).....	2.80	2.80	2.80	2.20	2.80	2.80	2.80	2.80
Bullet length (in.).....	1.28	1.18	1.14	1.35	1.35	1.28	1.19	1.14

Abbreviations: G.M.-Gilding Metal (Bullet Jacket Material)  
 G.M.C.S.-Gilding Metal, Clad Steel (Bullet Jacket Material)  
 N.R.-No record

**Section III. IDENTIFICATION**

**4-5. Cartridge Markings**

Ammunition intended for standardized NATO use is identified by means of a symbol resembling a plus sign in a circle (+). This symbol is stamped on the head of each service type 7.62 millimeter cartridge along with the manufacturer's mark and the year of manufacture. Interchangeable 7.62 millimeter ammunition (para 4-2) is further identified by means of a clover leaf symbol marked on the outer shipping containers. Ammunition of foreign manufacture, bearing both of the above symbols, is equally usable in U. S. weapons. Issue and use of individual cartridge lots, in the appropriate types of weapons, shall comply with the ammunition lot grades and authorizations noted in SC-1305-30-IL.

**4-6. Color Codes**

a. 7.62 millimeter cartridges removed from their original packing containers may be identified by color coding on the tip of the bullet (fig. 4-1); a black tip

**4-8. General**

a. Care must be used in the handling of any ammunition, however 7.62 millimeter ammunition for the machine gun M134, as compared with other types of ammunition, is not dangerous to handle.

identifies the M61, plain tips identify the M59 and M80, and the M62 has an orange tip.

b. The dummy cartridge, used to check the operation cycle through the delinking feeder MAU-56/A and machine gun M134 must be the smooth case M172. It is identified by its overall black oxide finish and contains an inert material in lieu of propellant to simulate the normal weight and balance of the ball cartridge. The dummy cartridge may be further identified by the absence of a primer, the omission of a vent hole under the primer pocket, and the lack of the NATO symbol stamped on the head.

**Caution: Do not use fluted case dummy cartridges.**

**4-7. Container Data**

Refer to SC 1305/30-IL for markings used to identify 7.62 millimeter ammunition packing cases and for other packing data.

**Section IV. CARE, HANDLING, AND PRESERVATION**

b. Ammunition is packed to withstand shipping, handling, and conditions ordinarily encountered in the field. Attention must be given to repairing any damaged containers to serviceable condition. If it is necessary to transfer ammunition to other containers, make certain that all markings are also transferred.

**4-9. Protection**

a. Precaution should be taken to assure that any cartridges used are free of foreign matter; are not dented or otherwise damaged; do not have loose bullets; or have not been overheated.

b. Do not open boxes until ammunition is to be used. Linked cartridges are ready to use when removed from packing material. Cartridges which were loaded into the armament subsystem and not fired will be

returned to their original packings or suitable packing boxes when removed from the armament subsystem. These cartridges should be the first used in subsequent firings.

c. Refer to TM 9-1300-206 for instructions on repacking, storing, inspection, and protection of ammunition.

## CHAPTER 5

**ADMINISTRATIVE STORAGE AND DESTRUCTION OF  
MATERIEL TO PREVENT ENEMY USE**

**Section I. ADMINISTRATIVE STORAGE**

**5-1. Storage**

a. Lack of time, trained personnel, or proper tools may result in a unit being incapable of performing maintenance for which it is responsible.

In such cases, unit commanders, with the approval of major commanders, may place the material in administrative storage or return it to supply agencies. When preparing for administrative storage, the commander will be responsible for processing the materiel, including all tools and equipment, in such a manner as to protect it against corrosion, deterioration, and physical damage.

b. With the exception of the reflex sight, all materiel, whether installed or removed from the armament subsystem XM27E1, will be cleaned, dried, and coated with a film of general purpose lubricating oil (PL Special) for temperatures above "0" degrees F; for temperatures below "0" degrees F, use weapons lubricating oil (LAW). Do not apply oil to the sight. Return sight to its carrying case whenever it is removed from the aircraft.

c. Administrative storage is restricted to a period of 90 days and must not be extended unless the materiel is reprocessed in accordance with instructions below.

d. Disassembly will be limited to that necessary to clean and coat surfaces with preservative (*b* above). Except as otherwise noted, and to the maximum extent consistent with safe storage, materiel will be placed in

administrative storage in as nearly a completely assembled condition as practicable.

e. Materiel should be stored in the most favorable location available, preferably one which affords protection from exposure to the elements and from pilferage.

f. Mark and tag materiel "Administrative Storage" and place tag in a convenient location. Materiel so marked will not be operated while in this category.

**5-2. Monthly Inspection**

a. Visual inspection of materiel in administrative storage must be conducted at least once each month. Disassembly, within scope of the organization, will be performed as necessary to fully ascertain the extent of deterioration or damage found. A record of these inspections will be maintained and attached thereto.

b. When rust or deterioration is found on any unpainted area, necessary reprocessing will immediately be accomplished. Painted surfaces showing evidence of rust, corrosion, etc., will be cleaned, dried, and repainted.

**5-3. Quarterly Service**

a. A quarterly preventive-maintenance service should be performed on all materiel. This consists of inspecting, cleaning, servicing, preserving, lubricating, adjusting, and replacement of repair parts, if required.

b. refer to TM 740-90-1 for supplemental instructions.

**Section II. DESTRUCTION OF MATERIEL TO PREVENT ENEMY USE**

**5-4. General**

**Note.** The information contained in the following paragraphs is in accordance with demolition information contained in

**International Standardization  
agreement STANAG 2113.**

a. It is essential to destroy to the maximum degree possible military technical equipment, abandoned on wartime operations, to prevent its eventual repair and use by the enemy.

**5-5. Degree of Damage**

a. Methods of destruction should achieve such damage to equipment and essential spare parts that it will not be possible to restore the equipment to a useable condition in the combat zone either by repair or cannibalization.

b. Classified equipment must be destroyed, whenever possible, in such degree as to prevent duplication by, or revealing means of operation or function to the enemy.

c. Any classified documents, notes, instructions, or other written materiel pertaining to function, operation, maintenance, or employment, including drawings or parts lists, must be destroyed in a manner to render them useless to the enemy.

**5-6. Priorities for Destruction**

a. Priority must always be given to the destruction of classified equipment and associated documents.

b. When lack of time and/or stores prevents complete destruction of equipment, priority is to be given to the destruction of essential parts, and the same parts are to be destroyed on all like equipment.

c. The priority for destruction of component parts for the armament subsystem XM27E1 shall be as follows:

- (1) Breech mechanism (rotor assembly).
- (2) Gun barrels.
- (3) Delinking feeder MAU-56/A.
- (4) Reflex sight XM70E1.
- (5) Mount assembly.

d. The same priority, for destruction of component parts of the armament subsystem XM27-E1, must be

given to the destruction of similar components in spare parts storage areas, if they can not be evacuated.

**5-7. Methods**

a. Ordinarily the armament should be destroyed in conjunction with the destruction of the helicopter.

b. If the materiel is off the helicopter, the armament subsystem can be destroyed by using one of the following methods:

(1) *Mechanical*. Requires axe, pick mattock, sledge, crowbar, or similar implement.

(2) *Burning*. Requires gasoline, oil, incendiary grenades, or other flammable, or welding or cutting torch.

(3) *Demolition*. Requires suitable explosives or ammunition.

(4) *Gunfire*. Includes artillery, machine guns, rifles using rifle grenades, and launchers using antitank rockets.

(5) *Disposal*. Requires burying in the ground, dumping in streams or marshes, or scattering so widely as to preclude recovery of essential parts.

**5-8. Authorization and Reporting**

a. The authority for ordering the destruction of equipment is vested in the divisional and higher commanders, who may delegate authority to subordinate commanders when the situation requires.

b. The reporting of the destruction of equipment is done through command channels.



## APPENDIX A

## REFERENCES

**1. Publication Indexes**

Consult each new issue of the following for the latest changes or revisions to publications listed in this appendix or for new publications on the materiel covered in this manual.

Index of Administrative Publications.....	DA Pam 310-1
Index of Blank Forms .....	DA Pam 310-2
Index of Doctrinal, Training, and Organizational Publications .....	DA Pam 310-3
Index of Supply Catalogs and Supply Manuals (excluding types 7, 8, and 9) .....	DA Pam 310-6
Index of Technical Manuals, Technical Bulletins, Supply Manuals (types 7, 8, and 9) Supply Bulletins, and Lubrication Orders .....	DA Pam 310-4

**2. Forms**

In addition to the forms required by the Department of the Army Equipment Record System (TM 38-750), the following forms pertain to this materiel:

Materiel Inspection Tag .....	DA Form 9-1
Recommended Changes to DA Publications .....	DA Form 2028
Report of Packaging and Handling Deficiencies .....	DD Form 6
Request for Issue or Turn-in .....	DA Form 2765 and DA Form 2765-1
Requirements for Army Aviation Publications .....	DA Form 12-31
Requisition for Publication's and Blank Forms .....	DA Form 17

**3. Other Publications**

The following publications contain information pertinent to this materiel and associated equipment.

*a. Ammunition*

Ammunition and Explosives .....	SC-1305/30-IL
Ammunition, General .....	TM 9-1900
Ammunition Service in the Theater of Operations .....	FM 9-6
Care, Handling, Preservation, and Destruction of Ammunition .....	TM 9-1300-206
Distribution of Ammunition for Training .....	AR 71-1300-1
Malfunctions Involving Ammunition and Explosives (reports control symbol AMC-132); .....	AR 700-1300-8
Regulations for Firing Ammunition for Training, Target Practice, and Combat (AFR 50-13) .....	AR 385-63

*b. Camouflage*

Camouflage, Basic Principles and Field Camouflage - .....	FM 5-20
---	---------

*c. Decontamination*

Chemical, Biological, and Radiological (CBR) Decontamination .....	TM 3-220
Chemical, Biological, and Nuclear Defense .....	FM 21-40

*d. Destruction to Prevent Enemy Use*

Explosives and Demolition .....	FM 5-25
---------------------------------	---------

*e. General*

Accident Reporting and Records ..... AR 385-40  
 Army Equipment Record System and Procedures ..... TM 38-750  
 Basic Cold Weather Manual..... FM 31-70

*f. Maintenance and Repair*

Cleaning of Ordnance Materiel..... TM 9-208-1  
 Command Maintenance Management Inspections ..... AR 750-8  
 Equipment Serviceability Criteria for Armament Subsystem, Helicopter: 7.62 Millimeter Machine Gun: High rate XM27E1 (Used on OH-6A Helicopter)..... TM 91005-298-ESC  
 General Maintenance Procedures for Fire Control Materiel ..... TM 9-254  
 Inspection, Care and Maintenance of Antifriction Bearings ..... TM 9-214  
 Lubrication of Ordnance Materiel ..... TM 9-273  
 Lubrication Order, Armament Subsystem, Helicopter, 7.62 Millimeter Machine Gun; High Rate, XM27E1 (1005-933-6242) ..... LO 9-105-298-12  
 Materials Used for Cleaning, Preserving, Abrading, and Cementing Ordnance Materiel: and Related Materials Including Chemicals ..... TM 9-247  
 Organization, Policies, and Responsibilities for Maintenance Operation ..... AR 750-5  
 Painting Instructions for Field Use ..... TM 9-213  
 Elementary Optics and Application to Fire Control Instruments ..... TM 9-258

*g. Operations*

Operation and Maintenance of Army Materiel in Extreme Cold Weather 0° to -65° F. .... TM 9-207

*h. Shipment and Storage*

DSU/Installation Stock Control and Supply Procedures (Army Field Stock Control Procedures) ..... AR 711-16  
 Preservation, Packaging, and Packing ..... AR 700-15  
 Requisitioning, Receipt, and Issue System ..... AR 725-50  
 Standards for Overseas Shipment or Domestic Issue of Small Arms, Aircraft Armament, Towed Howitzers, Mortars, Recoilless Rifles, Rocket Launchers, and Associated Fire Control Equipment ..... TB 9-1000-247-35  
 Storage and Materials Handling ..... TM 743-200-1

APPENDIX B

BASIC ISSUE ITEMS LIST

Section I. INTRODUCTION

1. Scope

This appendix lists items which accompany armament subsystem XM27E1 or are required for installation, operation, or operator's maintenance.

2. General

This Basic Issue Items List is divided into the following sections:

a. *Basic Issue Items-Section II.* A list of items which accompany the subsystem and are required by the operator/crew for installation, operation, or maintenance.

b. *Maintenance and Operating Supplies-Section III.* Not Applicable.

3. Explanation of Columns

The following provides an explanation of columns in the tabular list of Basic Issue Items, Section II.

a. *Source, Maintenance, and Recoverability Codes (SMR), Column 1:*

(1) Source code, indicates the selection status and source for the listed item. Source codes are:

Code	Explanation
P	Repair parts which are stocked in or supplied from the GSA/DSA, or Army supply system, and authorized for use at indicated maintenance categories,
P2	Repair parts which are procured and stocked for insurance purposes because the combat or military essentiality of the end item dictates that a minimum quantity be available in the supply system.
P9	Assigned to items which are NSA design controlled: unique repair parts, special tools, test, measuring and diagnostic equipment, which are stocked by the Army COMSEC logistic system, and which are not subject to the provisions of AR 380-41.
P10	Assigned to items which are NSA design controlled: special tools, test, measuring and diagnostic equipment for COMSEC support, which are accountable under the provisions of AR 380-41, and which are stocked and supplied by the Army COMSEC logistic system.
M	Repair parts which are not procured or stocked, but are to be manufactured at indicated maintenance levels.

Code	Explanation
A	Assemblies which are not procured or stocked as such, but which are made up of two or more units. Such component units carry individual stock numbers and descriptions, are procured and stocked separately and can be assembled to form the required assembly at indicated maintenance categories.
X	Parts and assemblies which are not procured or stocked and the mortality of which is below that of the applicable end item or component. The failure of such part or assembly should result in retirement of the end item from the supply system.
X1	Repair parts which are not procured or stocked. The requirements for such items will be filled by use of the next higher assembly or component.
X2	Repair parts which are not stocked. The indicated maintenance category requiring such repair parts will attempt to obtain same through cannibalization. Where such repair parts are not obtainable through cannibalization, requirements will be requisitioned, with accompanying justification through normal supply channels.
G	Major assemblies that are procured with PEMA funds for initial issue only as exchange assemblies at DSU and GSU level. These assemblies will not be stocked above DS and GS level or returned to depot supply level.
	(2) Maintenance Code, indicates the lowest category of maintenance authorized to install the listed item. The maintenance level codes are:
	Code                      Explanation
	C      Operator/Crew
	O      Organizational maintenance
	(3) Recoverability code, indicates whether unserviceable items should be returned for recovery or salvage. Items not coded are expendable. Recoverability codes are:
	Code                      Explanation
	R      Applied to repair parts (assemblies and components) which are considered economically repairable at Direct and General support main-

Code	Explanation
	tenance levels. When the maintenance capability to repair these items does not exist, they are normally disposed of at the GS level. When supply considerations dictate, some of these repair parts may be listed for automatic return to supply for Depot level repair as set forth in AR 710-50. When so listed, they will be replaced by supply on an exchange basis.
S	Repair parts and assemblies which are economically repairable at DSU and GSU activities and which normally are furnished by supply on an exchange basis. When items are determined by a GSU to be economically repairable they will be evacuated to a depot for evaluation and analysis before final disposition.
T	High dollar value recoverable repair parts which are subject to special handling and are issued on an exchange basis. Such repair parts normally are repaired or overhauled at depot maintenance activities.
U	Repair parts specifically selected for salvage by reclamation units because of precious metal content, critical materials, or high dollar value reusable casings or castings.
	<i>b. Federal Stock Number, Column 2.</i> This column indicates the Federal stock number assigned to the item and will be used for requisitioning purposes.
	<i>c. Description, Column 3.</i> This column indicates the Federal item name and any additional description of the item required. The abbreviation "w/e", when used as a part of the nomenclature, indicates that the Federal stock number includes all armament, equipment, accessories, and repair parts issued with the item. A part number or other reference number is followed by the applicable five-digit Federal supply code for manufacturers in parentheses.
	<i>d. Unit of Measure (U/M), Column 4.</i> A two character alphabetic abbreviation indicating the amount or quantity of the item upon which the allowances are based, e.g., ea, pr, ft, etc.
	<i>e. Quantity Incorporated in Unit, Column 5.</i> This column indicates the quantity of the item used in the assembly group. A "V" appearing in this column in lieu of a quantity indicates that a definite quantity cannot be indicated (e.g., shims, spacers, etc.).
	<i>f. Quantity Furnished With Equipment, Column 6.</i> This column indicates the quantity of an item furnished with the equipment.
	<i>g. Illustration, Column 7.</i> This column is divided as follows:

- (1) *Figure Number, Column 7a.* Indicates the figure number of the illustration in which the item is shown.
- (2) *Item Number, Column 7b.* Indicates the callout number user to reference the item in the illustration.

**4. Special Information**

*a. Major Combination and Components of Major Combination.*

(1) *Major combination.* Armament subsystem, helicopter, 7.62 millimeter machine gun: high rate XM27E1, w/e, FSN 1005-933-6242 is the major combination and is requisitioned for initial issue only.

(2) *Components of major combination.* The items listed below are issued as components of the major combination. Replacement items will be requisitioned separately under their individual stock numbers. When the major combination is turned in, all components will be turned in. The items are listed with quantity incorporated in the major combination, nomenclature, Federal stock number (FSN) or part number (PN) if unauthorized, and illustration reference.

- Gun Assembly PN 11697410 (fig. 1-1)
- Fairing Assembly PN 11697741 (fig. 1-1)
- Mount Assembly PN 11697405 (fig. 1-1)
- Sight, Reflex Assembly, XM70E1, w/carrying case, FSN 1270-832-5895 (fig. 1-1)
- Decal PN 11697403 (fig. 1-1)

**5. Abbreviations**

Abbreviation.....	Explanation
ASSY .....	assembly
EA .....	each
LSA-T .....	Lubricating oil, semifuild, low-friction
OZ .....	ounces
PN .....	part number
W/E .....	with equipment-indicates federal stock number includes all armament, equipment, and repair parts issued with the item.

**6. Federal Supply Code for Manufacturers**

Code	Manufacturer
02731	Hughes Tool Company-Aircraft Division Centinela at Teale Culver City, California 90230
19205	*Springfield Armory Springfield, Massachusetts *Responsibility for Springfield Armory (19205) has been assumed by Rock Island (19204).

Section II. BASIC ISSUE ITEMS

(1) SMR Code	(2) Federal Stock Number	(3) Description  Reference Number & Mfr. Code                      Usable On Code		(4) Unit of meas	(5) Qty inc in unit	(6) Qty furn with equip	(7) Illustration	
							(a) Fig No.	(b) Item No.
		<b>REPAIR PARTS FOR GUN ASSY</b>						
		NONE AUTHORIZED						
		<b>TOOLS AND EQUIPMENT FOR GUN ASSY</b>						
-P-C--	1005-556-4174	BRUSH, CLEANING, SMALL ARMS: bore, PN 5564174 (19205)		EA		2	3-3	4
-P-C--	1005-690-3115	BRUSH, CLEANING, SMALL ARMS: chamber, PN 7790-452(19205)		EA		1	3-3	5
-P-C--	1005-650-4508	BRUSH, CLEANING, SMALL ARMS: rotor, PN 7790342 (19205)		EA		2	3-3	6
-P-C--	1005-793-6761	HANDLE ASSY, PN 7266115 (19205)		EA		1	3-3	1
-P-C--	7510-763-5996	ENVELOPE, TRANSPARENT: MIL-E-43183 (81349)		EA		1		
-P-C--	1005-726-6109	SECTION, CLEANING ROD: PN 7266109 (19205)		EA		5	3-3	2
-P-C--	1005-726-7110	HOLDER, CLEANING PATCH: PN 7269110 (B19205)		EA		1	3-3	3
-P-C--	1005-694-1662	BUFFER, MUZZLE PROTECTOR: PN 7268275 (19205)		EA		1	3-3	8
-P-C--	9150-949-0323	LUBRICATING OIL, LSA-T, 8 OZ TUBE: PN R1APD688 (19205)		EA		1		
-P-C--	1005-933-6240	<b>REPAIR PARTS FOR MOUNT ASSY</b> CONTAINER, AMMUNITION PN 11697700 (02731)		EA		1	3-17	
		<b>TOOLS AND EQUIPMENT FOR MOUNT ASSY</b>						
		NONE AUTHORIZED						
		<b>REPAIR PARTS FOR SIGHT, REFLEX, ASSY XM70E1</b>						
		NONE AUTHORIZED: THE FOLLOWING REPAIR PARTS ARE STORED IN THE CARRYING CASE						
-P-C--	6240-155-7840	LAMP, 28 VDC DUAL FILAMENT: PN 10547031 (02731)		EA		1	3-2	
-P-C--	1270-902-3911	BEAMSPLITTER: PN 10547474 (02731)		EA		1	3-2	
		<b>MISCELLANEOUS MATERIAL</b>						
		ARMY TECHNICAL MANUAL TM 9-1005-298-12		EA		1		
		ARMY LUBRICATION ORDER LO 9-1005-298-12		EA		1		
		<b>AMMUNITION</b>						
		AMMUNITION FOR USE WITH THIS WEAPON IS LISTED IN SC-1305/301L. FOR TRAINING ALLOWANCE CONCERNING AMMUNITION OTHER THAN DUMMY CARTRIDGE, SEE TA 23-100. FOR ALLOWANCES CONCERNING M172 DUMMY CARTRIDGES (SMOOTH CASE), SEE TA 23-103.						

APPENDIX C

MAINTENANCE ALLOCATION CHART

**1. Scope**

The Maintenance Allocation Chart (DA Form 3047-R) identifies for each component and assembly of the end item the maintenance operations that must be performed, and assigns each of these operations to the lowest level of maintenance capable of performing the task in terms of the availability of time, tools, test and support equipment, skills, and employment of the item.

**2. General**

DA Form 3047-R is divided into four sections.

a. Section I of DA Form 3047-R contains definitions of the several classes of maintenance operations.

b. Section II is the maintenance assignment portion and contains the following data elements.

(1) *Functional group number.* The numerical scheme for grouping related components and assemblies as established by generation breakdown (item within next assembly) sequence of those elements.

(2) *Component assembly nomenclature.* A listing of the components and assemblies (less attaching parts) applicable to the end item and susceptible to maintenance.

(a) A component is a group of connected assemblies and parts which is capable of operation

independently, but which may be externally controlled or which may derive its power from another source.

(b) An assembly is a group of two or more physically connected or related parts which is capable of disassembly.

(3) *Maintenance function.* The assignment of each item's maintenance operations to the lowest level of maintenance is recorded in the appropriate column by the maintenance level symbol "O" for organizational, "F" for direct support, "H" for general support and "D" for depot maintenance.

(4) *Reference columns.* Columns are provided for referencing the special tool and test requirements and remarks that may be associated with each item's maintenance operations. A reference scheme is used in these columns to correlate the tools and test equipment or the remarks in sections III and IV with the associated maintenance operation assignments.

c. Section III provides listings and identification for any special tool or test requirement referenced in the "Tools and Equipment" column of Section II.

d. Section IV provides explanations and supplemental instruction for items referenced in the "Remarks" column of Section II.

**Section I. GENERAL**

This Maintenance Allocation Chart designates overall responsibility for the performance of maintenance functions on the identified end item or component. The

implementation of field Maintenance tasks upon this end item or component will be consistent with the assigned maintenance operations which are defined as follows:

Operation	Definition
Inspect	To verify serviceability and detect incipient electrical or mechanical failure by close visual examination.
Test	Verify serviceability and detect incipient failure by measuring the mechanical or electrical characteristics of the item and comparing those characteristics with authorized standards. Test will be made commensurate with test procedure and with calibrated tools or test equipment, section III.
Service	Operations required periodically to keep the item in proper operation condition, i.e., to clean, preserve, drain, paint, and replenish fuel, lubricants, hydraulic, and deicing fluids or compressed air supplies.

Operation	Definition
Adjust	To regulate periodically to prevent malfunction, adjustments will be made commensurate with adjustment procedures and associated equipment adjustment specifications.
Align	To adjust two or more components of an electrical or mechanical system so that their functions are properly synchronized.
Calibrate	To determine, to check, or to rectify the graduation of an instrument, weapon, or weapons system or components of a weapons system.
Install	Remove and install the same item for service or when required for the performance of other maintenance operations.
Replace	Substitute serviceable components, assemblies, and subassemblies for unserviceable counterparts.
Overhaul	Restore to a serviceable condition by replacing unserviceable parts or by any other action required, using available tools, equipment, and skills including welding, grinding, riveting, straightening, adjusting, and facing.
Rebuild	Restore an item to completely serviceable condition (as prescribed by serviceability standards developed and published by the commodity commands) by employing techniques of "Inspect and Repair Only as Necessary" (IROAN). Maximum use of diagnostic and test equipment is combined with minimum disassembly during overhaul. "Overhaul" may be assigned to any level of maintenance except organizational, provided the time, tools, equipment, repair parts authorization and technical skills are available at that level. Normally, overhaul as applied to end items, is limited to depot maintenance level.
Symbol C, O, F, H and D	Restore to a condition comparable to new by disassembling to determine the condition of each component part and assembling using serviceable, rebuilt, or new assemblies, subassemblies, and parts.
Symbol "%%"	The symbols Crew/Operator), O (Organizational), F (Direct Support), H (General Support), and D (Depot) placed in the appropriate column indicate the lowest maintenance level responsible for performing that particular maintenance operation, but do not necessarily indicate that repair parts will be stocked at that level. Maintenance levels higher than the indicated level are also authorized to perform the indicated operation.
Symbol "%%"	Indicates that organizational maintenance level may perform the particular maintenance function, provided the request originates from organizational level and is specifically authorized by the direct support maintenance officer. Use of the symbol will be strictly limited and will apply only to replacement of major assemblies within the capabilities of, and time available to organizational maintenance, but over which control is considered essential. In no case will the direct support maintenance officer require performance of a "%%" maintenance function by an organization unit, and in no case will a "%%" function authorize stockage of parts at organizational level.

**Armament Subsystem XM27E1  
SECTION II-MAINTENANCE ASSIGNMENT**

a G R O U P  N U M B E R	b  Functional Group	c  Maintenance functions										d  Tools and equipment	e  Remarks	
		I N S P E C T	T E S T	S E R V I C E	A D J U S T	A L I G N	C A L I B R A T E	I N S T A L L	R E P L A C E	R E P A I R	O V E R H A U L			R E B U I L D
1	Armament Subsystem, Helicopter, 7.62 Millimeter Machine Gun: XM27E1	O	--	O	--	O	--	O	--	O	H	D	1, 2, 3 & 4	
2	Gun Assembly	O	--	O	--	--	--	O	--	O	--	--	2	
3	Machine Gun, 7.62 Millimeter: M134	O	F	O	--	--	--	O	O	O	H	--	2 & 3	
4	Bolt Assembly	O	--	O	--	--	--	O	O	O	O	--	2	
5	Barrel	O	--	O	--	--	--	O	O	--	--	--	2	
6	Rotor Assembly	O	H	O	--	--	--	O	--	O	--	--	2 & 3	
7	Feeder Delinking MAU-56/A	O	--	O	--	--	--	O	O	O	--	--	2	
8	Drive Assembly, Electric Gun	O	--	O	--	--	--	O	--	O	D	--	2 & 3	
9	Fairing Assembly	O	--	O	--	--	--	O	--	O	--	--	2	
10	Container Assembly, Ammunition	O	--	O	--	--	--	O	O	O	--	--	2	
11	Chute, Ammunition	O	--	O	--	--	--	O	O	--	--	--	2	
12	Control Box Assembly	O	F	O	--	--	--	O	O	O	D	--	2 & 3	
13	Electric Cabling	O	F	O	--	--	--	O	O	F	--	--	2 & 3	
14	Rod Assembly, Control (Sight Drive)	O	--	O	--	--	--	O	O	O	--	--	2	
15	Housing and Tube Assembly	O	--	O	--	--	--	O	--	O	H	--	2, 3 & 4	
16	Housing Assembly	O	--	O	--	--	--	O	--	F	--	--	2, 3 & 4	
17	Tube Assembly	O	--	O	--	--	--	O	--	O	--	--	2 & 3	
18	Sight, Reflex: XM70E1	O	--	O	--	--	--	O	O	F	H	--	5, 6, 7 & 8	
19	Support Assembly	O	--	O	--	--	--	O	F	O	H	--		
20	Control Assembly, Elevation	O	--	O	--	--	--	O	F	F	H	--		
21	Projector Assembly	O	--	O	--	--	--	O	F	O	H	--		
22	Case, Carrying	O	--	O	--	--	--	--	F	--	--	--		

**SECTION III-TOOL TEST EQUIPMENT REQUIREMENTS**

Tool or Test Equipment Ref Code	Maintenance Category	Nomenclature	FSN	Tool Number
1	0	Boresight Kit:	4933-980-1957	
2	O-F-D	Tool Set, Aircraft Armament Repairman: MOS 45J Basic	4833-987-9816	
3	F-D	Tool Set, Aircraft Armament Repairman: MOS 45J Supplemental	4933-994-9242	
4	O-F-H-D	Wrench, Adjusting, Forward Bearing	5120-052-3873	
5	H-D	Collimating Adapter, Final Inspection	4931-936-5403	
6	H-D	Crossleveling and Elevation Fixture	4931-652-3553	
7	O-F-H-D	Kit, Adapter Assembly	4931-936-4283	
8	O-F-H-D	Tool Set, Purging Fire Control	4931-065-1110	













APPENDIX D

ELECTRICAL SYMBOLS

1. Electrical Symbols

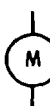
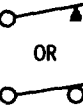
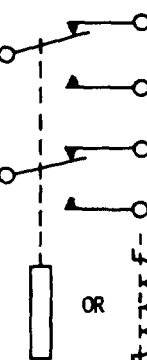
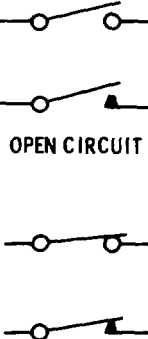
See figure D-1 for the graphic symbols used in the schematic wiring diagrams for the subsystem

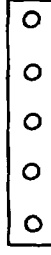
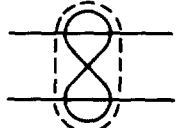
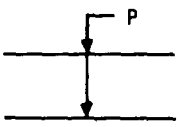
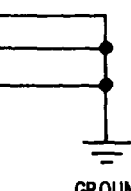
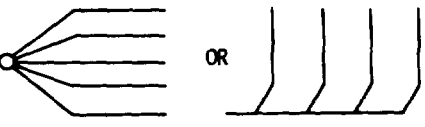
				
FIXED RESISTOR	VARIABLE RESISTOR	FIXED CAPACITOR	FIXED POLARIZED CAPACITOR	COIL
				
RECTIFIER DIODE	BREAKDOWN DIODE	DUAL FILAMENT LAMP	MOTOR	SWITCH
				
RELAY	CLOSED CIRCUIT	CONNECTOR PLUG	CONNECTOR RECEPTACLE	TERMINAL BOARD
				
SHIELDED CABLE	WIRES TWISTED PAIR	JUNCTIONS	GROUPING OF LEADS	
TWISTED PAIR		GROUND		

WE 15621A

Figure D-1. Electrical symbols.

## INDEX

	Paragraph	Pages
Adapter (See specific application)		
Adjustment		
Boresighting .....	2-12	2-10
Control Rod .....	3-21e	3-24
Elevation Knob .....	2-8	2-8
Height Control .....	2-8	2-8
Ammunition .....	4-1	4-1
Ammunition Chutes .....	3-21c	3-24
Ammunition Container		
Assembly .....	3-21a	3-24
Disassembly .....	3-21a	3-24
Installation .....	2-2	2-1
Loading .....	2-16	2-13
Removal .....	2-2	2-1
Repair .....	3-22c	3-27
Unloading .....	2-17	2-13
Assembly Procedures (See specific item)		
Ballistic Data .....	4-4	4-1
Barrel		
Installation .....	3-11d	3-14
Removal .....	3-11d	3-14
Repair .....	3-12c	3-18
Service .....	3-12	3-17
Barrel Clamp Assembly		
Installation .....	3-11d	3-14
Removal .....	3-11d	3-14
Repair (Also see Spline Nut) .....	3-12c	3-18
Beamsplitter .....	3-24a	3-31
Removal .....	3-24a	3-31
Installation .....	3-11h	3-17
Bearing (See specific application)		
Bolt Assembly		
Assembly .....	3-11h	3-17
Disassembly .....	3-11h	3-17
Installation .....	3-11b	3-14
Removal .....	3-11b	3-15
Repair.....	3-12c	3-18
Bolthead (See Bolt Assembly)		
Boresighting .....	2-12	2-10
Boresight Adapter .....	2-13	2-11
Boresight Scope .....	2-13	2-11
Cable Assembly (See specific application) .....	2-13	2-11
Cam Housing (See Delinking Feeder)		
Carrying Case (See Reflex Sight assembly)		
Cartridge .....	4-3	4-1
Cartridge Ejection Chute		
Installation .....	2-4a	2-3
Removal .....	2-4a	2-3
Repair .....	3-10c	3-14
Caution Plate (See Information Plate)		
Chute (See specific item)		
Clamp (See specific item)		
Cleaning Tools (See Gun Cleaning Tools)		
Clearing (See Unloading) .....	2-17	2-13
Container (See specific item)		
Controls .....	2-8	2-8

Control Assembly, Gun Electric Drive		
Installation .....	3-15	3-21
Removal .....	3-15	3-21
Repair .....	3-16d	3-21
Control Box Assembly		
Installation .....	3-21b	3-24
Removal .....	3-21b	3-24
Repair .....	3-22	3-24
Control Rod		
Delinking Feeder		
Assembly .....	3-13	3-20
Disassembly .....	3-13	3-20
Installation .....	2-5f	2-3
Removal .....	2-5f	2-3
Repair .....	3-14c	3-20
Timing .....	2-5d	2-3
Destruction of Equipment		
Authorization .....	5-8a	5-2
Degree of Damage .....	5-5	5-2
Methods .....	5-7	5-2
Priorities .....	5-6	5-2
Reporting .....	5-8b	5-2
Disassembly (See specific item)		
Door Filler		
Installation .....	2-2	2-1
Removal .....	2-2	2-1
Repair .....	3-22c	3-27
Dual Filament Lamp (See Reflex Sight Lamp)		
Dummy Cartridge .....	4-3d	4-1
Gun Electric Drive Assembly		
Assembly .....	3-15	3-21
Disassembly .....	3-15	3-21
Installation .....	2-4	2-3
Removal .....	2-4	2-3
Repair .....	3-16d	6-21
Electrical Schematic Diagram .....	3-7a	3-6
Electrical Symbols .....	3-7a	3-6
Fairing Assembly		
Assembly .....	3-18	3-22
Disassembly .....	3-18	3-22
Installation .....	2-6	2-3
Removal .....	2-6	2-3
Repair .....	3-19c	3-22
Feeder Sprocket (See Delinking Feeder)		
Firing Pin (See Bolt Assembly)		
Forms .....	1-2a	1-1
Guide (See specific item)		
Guide Bar		
Installation .....	3-11c	3-14
Removal .....	3-11c	3-14
Repair .....	3-12c	3-18
Gun (M134)		
Assembly .....	3-11	3-14
Components (See specific item)		
Disassembly .....	3-11	3-14
Loading Procedures (See Loading)		
Repair .....	3-12c	3-18
Timing .....	2-5d	2-3
Gun Assembly		
Assembly .....	2-4	2-3
Components (See specific item)		
Disassembly .....	2-4	2-3
Installation .....	2-5	2-3
Removal .....	2-5	2-3
Repair .....	3-10c	3-14

Gun Bearing		
Installation .....	3-11f	3-16
Removal .....	3-11f	3-16
Gun Cleaning Tools		
Gun Drive Cable		
Installation .....	3-21b	3-24
Removal .....	3-21b	3-24
Gun Drive (See Gun Electric Drive Assembly)		
Gun Housing		
Installation .....	3-11f	3-16
Removal .....	3-11f	3-16
Repair .....	3-12c	3-18
Height Adjustment (See Adjustment)		
Housing (See Gun Housing)		
Housing and Tube Assembly (See Mount Assembly)		
Identification Plate .....	1-7	1-10
Information Plate .....	1-7	1-10
Installation (See specific item)		
Instruction Plate .....	1-7	1-10
Lamp		
Reflex Sight .....	3-24b	3-31
Spare for Reflex Sight (See Reflex Sight-Carrying Case)		
Link Ejection Chute		
Installation .....	2-4b	2-3
Removal .....	2-4b	2-3
Repair .....	3-10c	3-14
Link Guide (See Delinking Feeder)		
Loading .....	2-16	2-13
Lubrication .....	3-5	3-4
Motor and Sensor Assembly .....	3-21c	3-24
Mounting Adapters		
Installation .....	2-4a	2-3
Removal .....	2-4a	2-3
Repair .....	3-10c	3-14
Mount Assembly		
Assembly .....	3-21	3-24
Disassembly .....	3-21	3-24
Installation .....	2-2	2-1
Removal .....	2-2	2-1
Repair .....	3-22c	3-27
Nose Guide		
Installation .....	2-4b	2-3
Removal .....	2-4b	2-3
Repair .....	3-10c	3-14
Operation Procedure.		
With Power .....	2-11	2-9
Without Power .....	2-10	2-9
Packing Material .....	3-2	3-1
Purging (See Reflex Sight Assembly)		
Pushbutton Fastener Stud .....	2-3	2-1
Push Rod (See Delinking Feeder)		
Push Rod Roller (See Delinking Feeder)		
Rear Gun Support		
Installation .....	3-11e	3-16
Removal .....	3-11e	3-16
Repair .....	3-12c	3-18
Reflex Sight Assembly		
Assembly .....	3-24	3-31
Carrying Case .....	3-2	3-1
Disassembly .....	3-24	3-31
Installation .....	2-3	2-1
Purging .....	3-26	3-32

Removal .....	2-3	2-1
Repair .....	3-25c	3-32
Removable Tracks		
Installation .....	3-11b	3-14
Removal .....	3-11b	3-14
Repair .....	3-12c	3-18
Rotor Assembly		
Assembly .....	3-11f	3-16
Disassembly .....	3-11f	3-16
Components .....	3-11f	3-16
Installation .....	3-11f	3-16
Removal .....	3-11f	3-16
Repair .....	3-12c	3-18
Safing Sector		
Installation .....	3-11a	3-14
Removal .....	3-11a	3-14
Repair .....	3-12c	3-18
Schematic Diagram .....	3-7	3-6
Sensing Unit and Cable Assembly		
Installation .....	2-4b	2-3
Removal .....	2-4b	2-3
Repair .....	3-10c	3-14
Sight (See Reflex Sight Assembly)		
Sight Control Rod		
Adjustment Procedure (See Adjustment)		
Assembly .....	3-21e	3-24
Disassembly .....	3-21e	3-24
Installation .....	2-3c	2-3
Removal .....	2-3c	2-3
Repair .....	3-22c	3-27
Solenoid (See Delinking Feeder)		
Spline Nut		
Installation .....	3-11d	3-14
Removal .....	3-11d	3-14
Storage.....	5-1	5-1
Symbols (See Electrical Symbols)		
Timing (See specific item)		
Tracks (See Removable Tracks)		
Troubleshooting Procedures.....	3-7	3-6

By Order of the Secretary of the Army:

W. C. WESTMORELAND,  
*General, United States Army,*  
*Chief of Staff.*

Official:

KENNETH G. WICKHAM,  
*Major General, United States Army,*  
*The Adjutant General.*

Distribution:

To be distributed in accordance with DA Form 12-31 (qty rqr Block #128), Organizational maintenance requirements for Armament Subsystem XM27E1.

RECOMMENDED CHANGES TO EQUIPMENT TECHNICAL PUBLICATIONS



*THEN...JOT DOWN THE DOPE ABOUT IT ON THIS FORM. CAREFULLY TEAR IT OUT, FOLD IT AND DROP IT IN THE MAIL.*

**SOMETHING WRONG WITH PUBLICATION**

FROM: (PRINT YOUR UNIT'S COMPLETE ADDRESS)

DATE SENT

PUBLICATION NUMBER

PUBLICATION DATE

PUBLICATION TITLE

**BE EXACT PIN-POINT WHERE IT IS**

PAGE NO.	PARA-GRAPH	FIGURE NO.	TABLE NO.

**IN THIS SPACE, TELL WHAT IS WRONG AND WHAT SHOULD BE DONE ABOUT IT.**

PRINTED NAME, GRADE OR TITLE AND TELEPHONE NUMBER

SIGN HERE

## The Metric System and Equivalents

### *Linear Measure*

1 centimeter = 10 millimeters = .39 inch  
 1 decimeter = 10 centimeters = 3.94 inches  
 1 meter = 10 decimeters = 39.37 inches  
 1 dekameter = 10 meters = 32.8 feet  
 1 hectometer = 10 dekameters = 328.08 feet  
 1 kilometer = 10 hectometers = 3,280.8 feet

### *Weights*

1 centigram = 10 milligrams = .15 grain  
 1 decigram = 10 centigrams = 1.54 grains  
 1 gram = 10 decigrams = .035 ounce  
 1 decagram = 10 grams = .35 ounce  
 1 hectogram = 10 decagrams = 3.52 ounces  
 1 kilogram = 10 hectograms = 2.2 pounds  
 1 quintal = 100 kilograms = 220.46 pounds  
 1 metric ton = 10 quintals = 1.1 short tons

### *Liquid Measure*

1 centiliter = 10 milliliters = .34 fl. ounce  
 1 deciliter = 10 centiliters = 3.38 fl. ounces  
 1 liter = 10 deciliters = 33.81 fl. ounces  
 1 dekaliter = 10 liters = 2.64 gallons  
 1 hectoliter = 10 dekaliters = 26.42 gallons  
 1 kiloliter = 10 hectoliters = 264.18 gallons

### *Square Measure*

1 sq. centimeter = 100 sq. millimeters = .155 sq. inch  
 1 sq. decimeter = 100 sq. centimeters = 15.5 sq. inches  
 1 sq. meter (centare) = 100 sq. decimeters = 10.76 sq. feet  
 1 sq. dekameter (are) = 100 sq. meters = 1,076.4 sq. feet  
 1 sq. hectometer (hectare) = 100 sq. dekameters = 2.47 acres  
 1 sq. kilometer = 100 sq. hectometers = .386 sq. mile

### *Cubic Measure*

1 cu. centimeter = 1000 cu. millimeters = .06 cu. inch  
 1 cu. decimeter = 1000 cu. centimeters = 61.02 cu. inches  
 1 cu. meter = 1000 cu. decimeters = 35.31 cu. feet

## Approximate Conversion Factors

<i>To change</i>	<i>To</i>	<i>Multiply by</i>	<i>To change</i>	<i>To</i>	<i>Multiply by</i>
inches	centimeters	2.540	ounce-inches	Newton-meters	.007062
feet	meters	.305	centimeters	inches	.394
yards	meters	.914	meters	feet	3.280
miles	kilometers	1.609	meters	yards	1.094
square inches	square centimeters	6.451	kilometers	miles	.621
square feet	square meters	.093	square centimeters	square inches	.155
square yards	square meters	.836	square meters	square feet	10.764
square miles	square kilometers	2.590	square meters	square yards	1.196
acres	square hectometers	.405	square kilometers	square miles	.386
cubic feet	cubic meters	.028	square hectometers	acres	2.471
cubic yards	cubic meters	.765	cubic meters	cubic feet	35.315
fluid ounces	milliliters	29.573	cubic meters	cubic yards	1.308
pints	liters	.473	milliliters	fluid ounces	.034
quarts	liters	.946	liters	pints	2.113
gallons	liters	3.785	liters	quarts	1.057
ounces	grams	28.349	liters	gallons	.264
pounds	kilograms	.454	grams	ounces	.035
short tons	metric tons	.907	kilograms	pounds	2.205
pound-feet	Newton-meters	1.356	metric tons	short tons	1.102
pound-inches	Newton-meters	.11296			

### Temperature (Exact)

°F	Fahrenheit temperature	5/9 (after subtracting 32)	Celsius temperature	°C
----	---------------------------	-------------------------------	------------------------	----



**PIN: 026418-000**

This fine document...

Was brought to you by me:



## [Liberated Manuals -- free army and government manuals](#)

Why do I do it? I am tired of sleazy CD-ROM sellers, who take publicly available information, slap “watermarks” and other junk on it, and sell it. Those masters of search engine manipulation make sure that their sites that sell free information, come up first in search engines. They did not create it... They did not even scan it... Why should they get your money? Why are not letting you give those free manuals to your friends?

I am setting this document FREE. This document was made by the US Government and is NOT protected by Copyright. Feel free to share, republish, sell and so on.

I am not asking you for donations, fees or handouts. If you can, please provide a link to [liberatedmanuals.com](http://liberatedmanuals.com), so that free manuals come up first in search engines:

<A HREF=<http://www.liberatedmanuals.com/>>Free Military and Government Manuals</A>

– Sincerely  
Igor Chudov  
<http://igor.chudov.com/>