

Applications of Arrays (1A)

Copyright (c) 2022 - 2010 Young W. Lim.

Permission is granted to copy, distribute and/or modify this document under the terms of the GNU Free Documentation License, Version 1.2 or any later version published by the Free Software Foundation; with no Invariant Sections, no Front-Cover Texts, and no Back-Cover Texts. A copy of the license is included in the section entitled "GNU Free Documentation License".

Please send corrections (or suggestions) to youngwlim@hotmail.com.

This document was produced by using LibreOffice.

Array **a** vs array pointer **A**

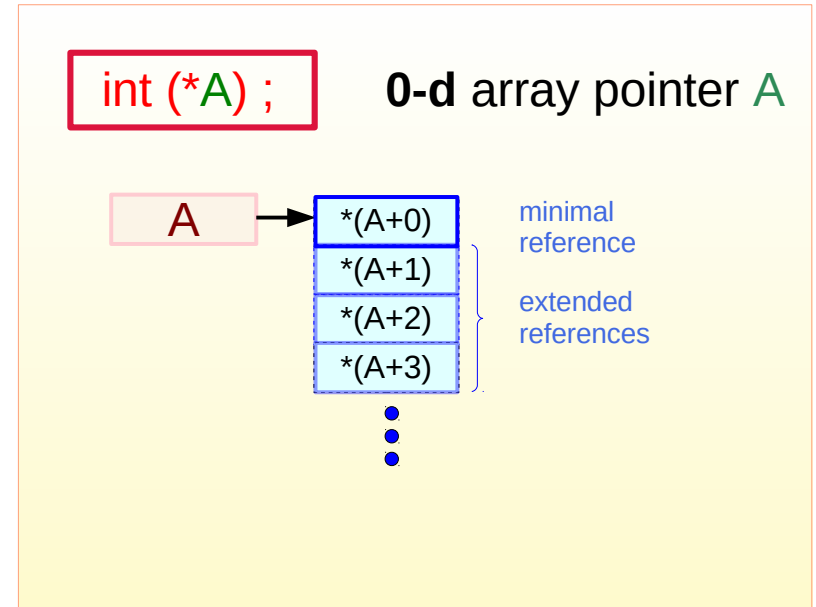
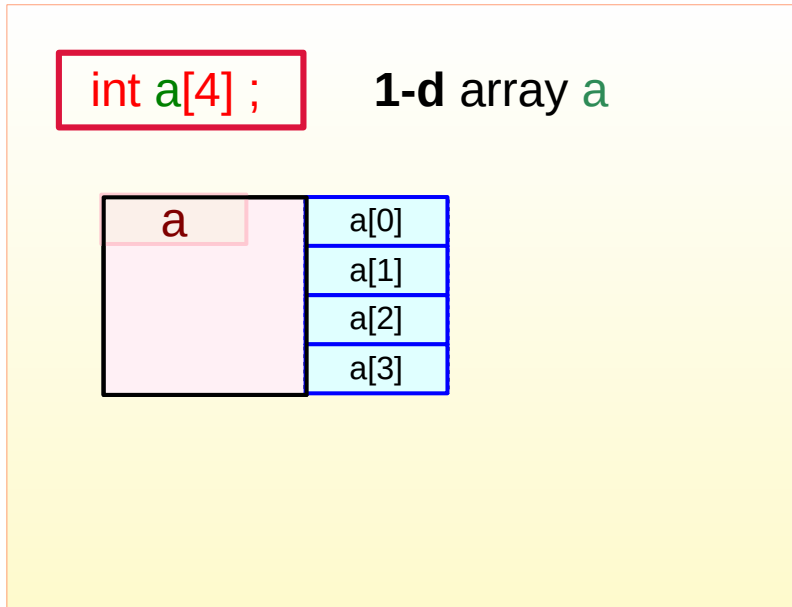

`int (*)` **a** as a 0-d array pointer

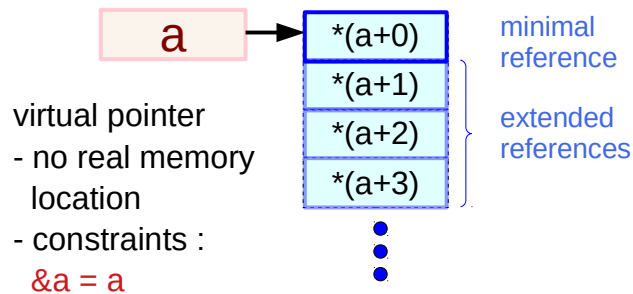

`int [N]` **A** as a 1-d array

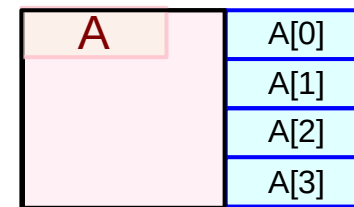

N is not fixed to 4

`sizeof(A)` is not the size of the array but the size of a pointer variable

Array **a** and array pointers **A**

`int a[4];` **1-d** array **a**

- `sizeof(a)` = an array size
= 4 * 4 bytes
- # of 0-d arrays = fixed
= 4

`int (*A);` **0-d** array pointer **A**

- `sizeof(A)` = a pointer size
= 4 / 8 bytes
- # of 0-d arrays = not fixed
= at least 1

`int (*)` **a** as a **0-d** array pointer

a is not a real pointer

- `sizeof(a)` = an array size
- `a = &a`

`int [N]` **A** as a **1-d** array

A is not a real array

- `sizeof(A)` = a pointer size
- `A ≠ &A`

The name of a 2-d array

```
int    a [4];
```

```
int    c [4] [4];
```

1. the name of the nested array (recursive definition)
2. a double pointer
3. a pointer to an array

2-d array access

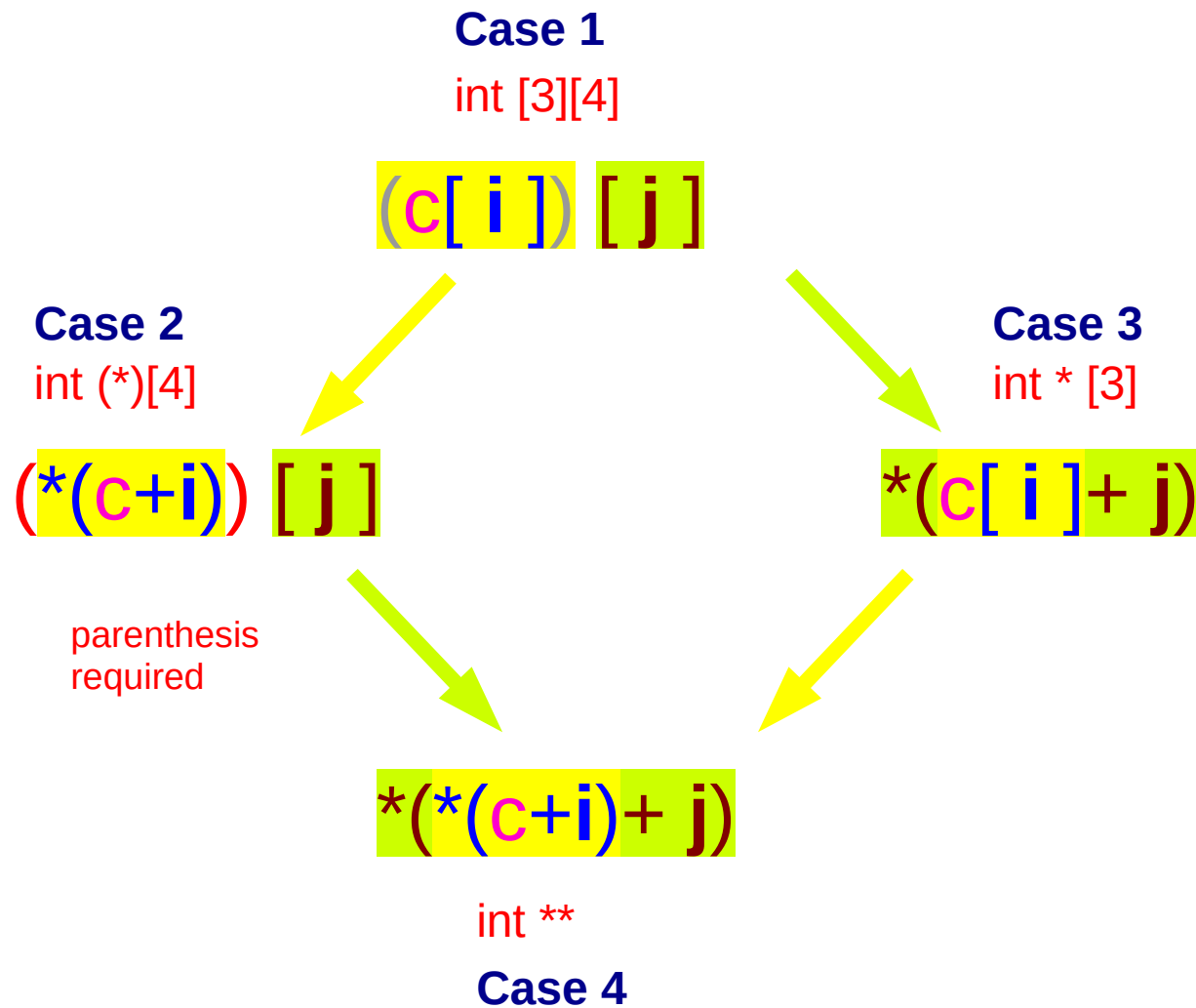

Case 1) 2-d array c, 1-d array c[i]

int c [3] [4]

c 2-d array

type : int [3][4]

int c [3] [4]

c[i] 1-d array

type : int [4]

(c[i])[j]

int [3][4]

int [4]

int

c	c[0]	c[0][0]
		c[0][1]
		c[0][2]
		c[0][3]
	c[1]	c[1][0]
		c[1][1]
		c[1][2]
		c[1][3]
	c[2]	c[2][0]
		c[2][1]
		c[2][2]
		c[2][3]

Case 2) 1-d array pointer **c**, 1-d array **c[i]**

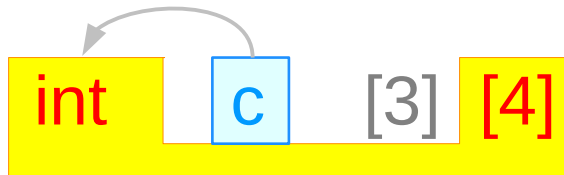

c 1-d array pointer

type : `int (*) [4]`

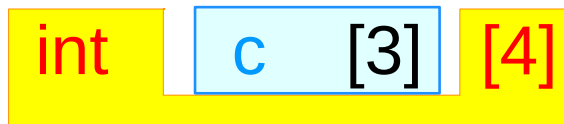

c[i] 1-d array

type : `int [4]`

`(*(c+i)) [j]`

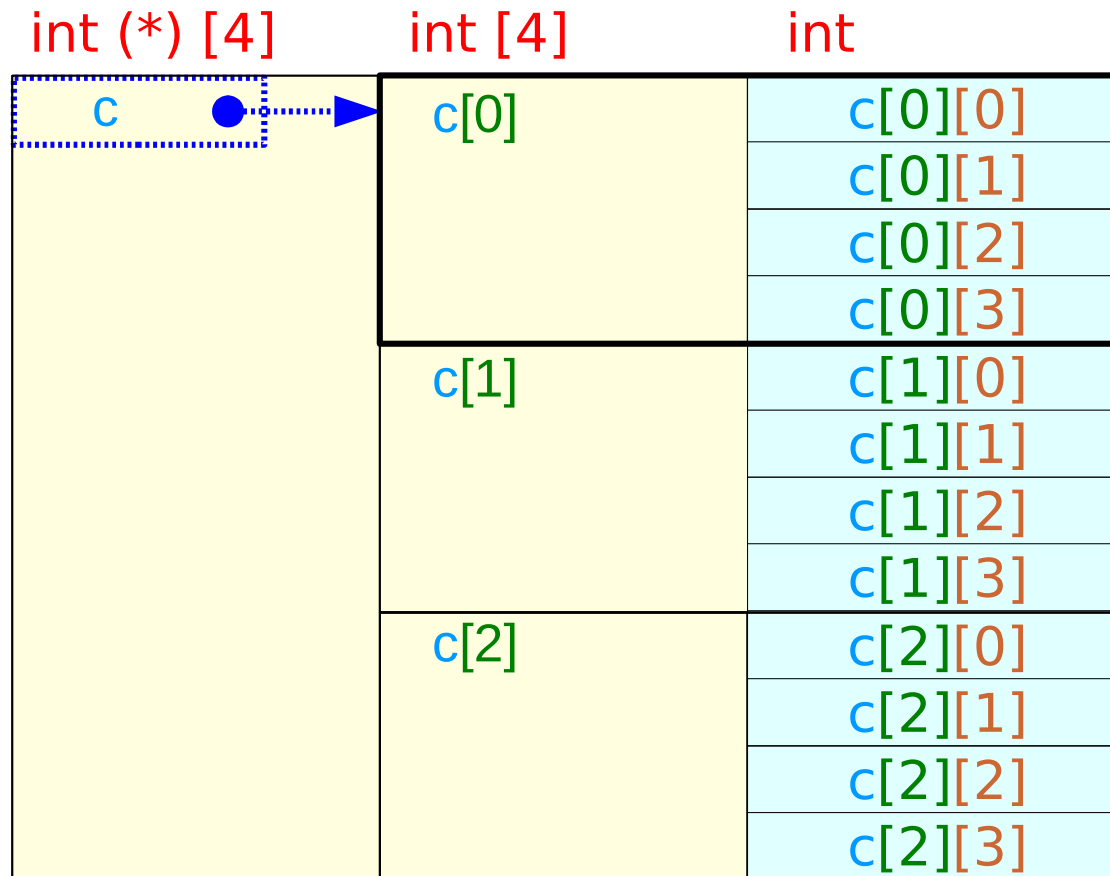

Case 3) 1-d array c, pointer c[i]

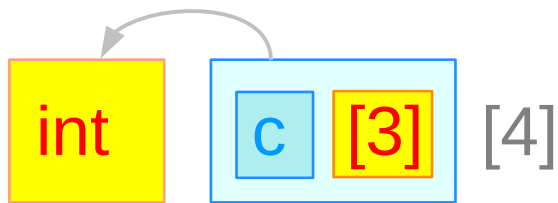

c 1-d array

type : int * [3]

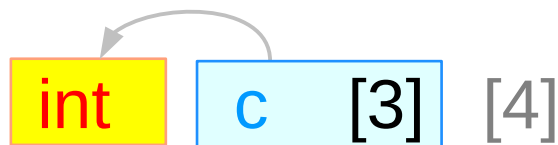

c[i] pointer

type : int *

***(c[i] + j)**

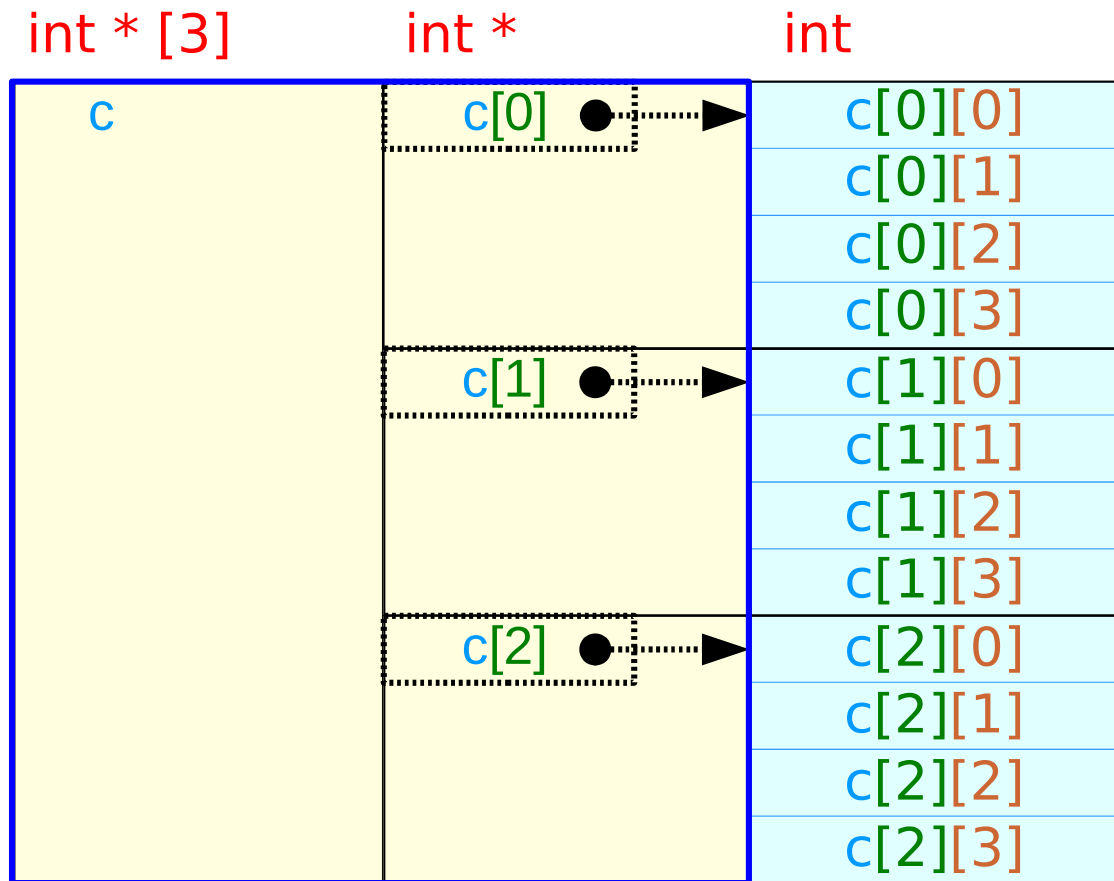

Case 4) double pointer **c**, pointer **c[i]**

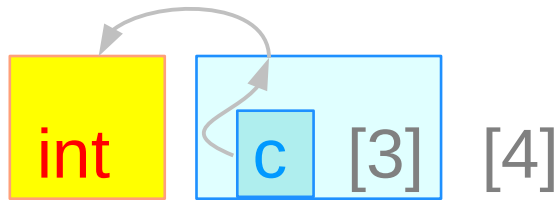

c double pointer

type : **int ****

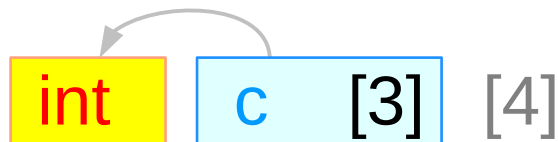

c[i] pointer

type : **int ***

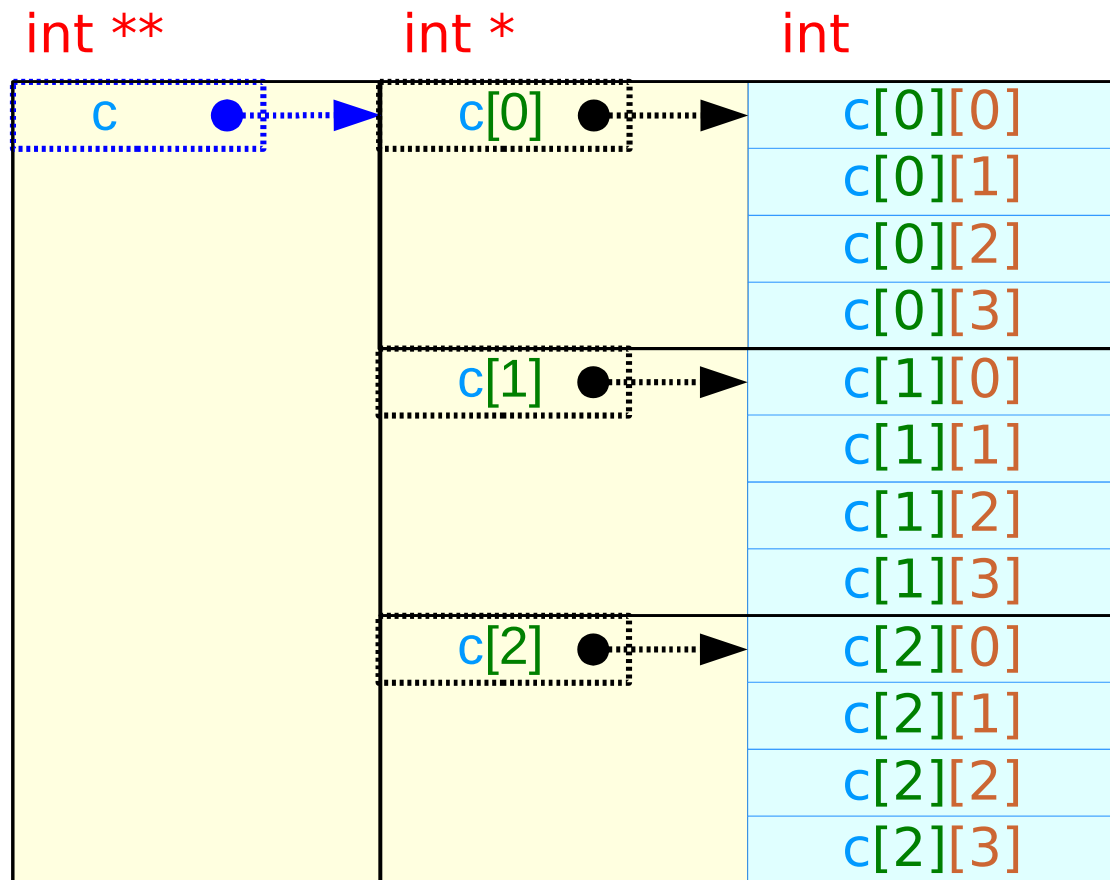

$*(*(c+i)+j)$

Types in a 2-d array

int c [3] [4]

C 2-d array

type : int [3][4]

size : 3 * 4 * 4

value : &c[0][0]

relaxing the 1st dimension



int c [3] [4]

C 1-d array pointer (virtual)

type : int (*) [4]

size : 3 * 4 * 4

value : &c[0][0]

int c [3] [4]

C[i] 1-d array

type : int [4]

size : 4 * 4

value : &c[i][0]

relaxing the 1st dimension



int c [3] [4]

C[i] 0-d array pointer (virtual)

type : int (*)

size : 4 * 4

value : &c[i][0]

c is a double pointer and a **1-d** array pointer

$*(*(\mathbf{c}+\mathbf{0})+\mathbf{0})$



****c**

a double pointer

$(*(\mathbf{c}+\mathbf{0}))[\mathbf{0}]$



(*c)[0]

a **1-d** array pointer

2-d array access via a double indirection

Case 1

int [3][4]

(c [i])[j]



Case 2

int (*)[4]

(*(c+i))[j]



Case 4

int **

((c+i)+j)

relax the 1st dimension

(c [i]) = (*(c+i))

contiguous memory locations are assumed

relax the 2nd dimension

(_) [j] = *((_)+j)

contiguous memory locations are assumed

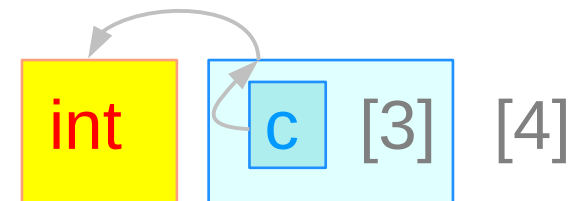
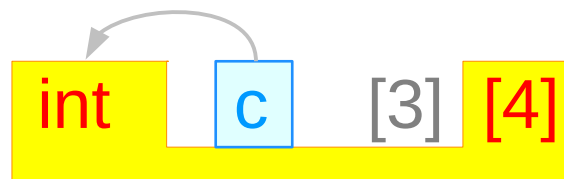

2-d array access via a double indirection

Case 1

int [3][4]

(c [i])[j]

relax the 2nd dimension

()[j] = *(+j)

contiguous memory
locations are assumed

Case 3

int * [3]

*((c [i])+j)

relax the 1st dimension

(c [i]) = (*(c+i))

contiguous memory
locations are assumed

Case 4

int **

((c+i)+j)

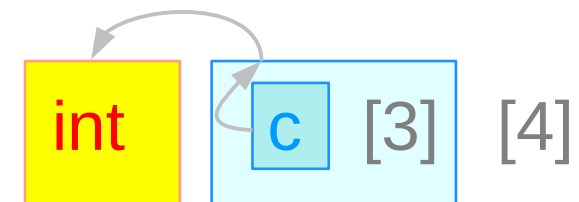
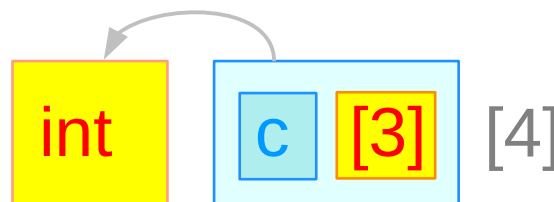
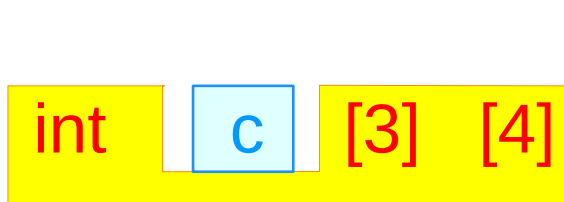

Cases 1, 2, 4

```
int c [3] [4];
```

```
int (*p) [4];
```

Case 1

int [3][4]

(c [i]) [j]

p = c

(p [i]) [j]

Case 2

int (*) [4]

(*(c+i)) [j]

equivalence

(*(p+i)) [j]

Case 4

int **

((c+i)+j)

((p+i)+j)



p[0]=c[0],
p[1]=c[1],
p[2]=c[2];

Cases 1, 3, 4

```
int c [3] [4];
```

```
int **p, *q[3];
```

Case 1

int [3][4]

(c [i])[j]

p = q;

(p [i])[j]

q[0]=c[0],
q[1]=c[1],
q[2]=c[2];

must be allocated
and initialized

Case 3

int * [3]

*((c [i])+j)

*((p [i])+j)

Case 4

int **

((c+i)+j)

((p+i)+j)

2-d array access using an array pointer p

```
int c [3] [4];
```

```
int (*p) [4];
```

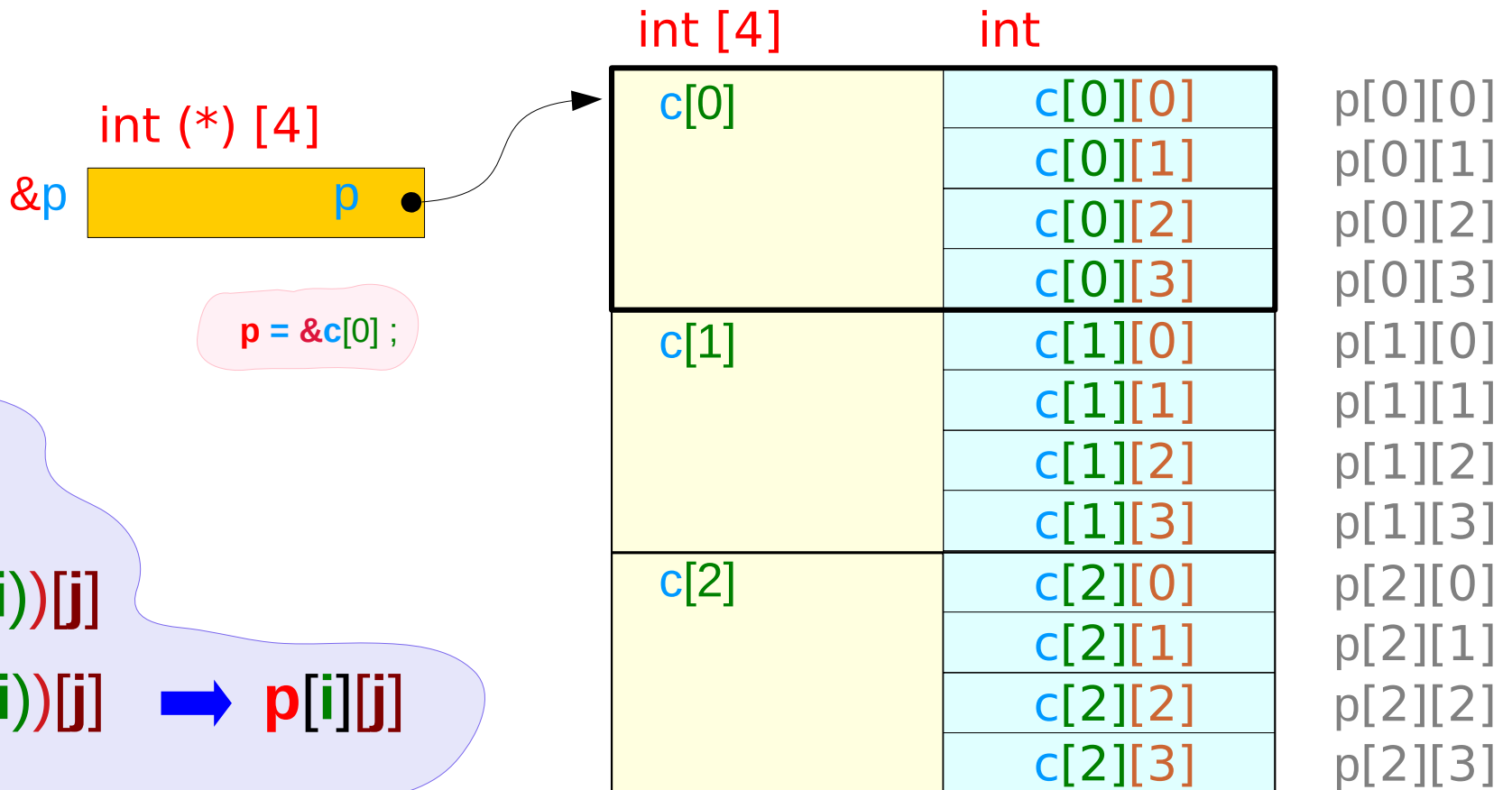

2-d array access using a pointer array q

```
int c [3] [4];
```

```
int *q[3];
```

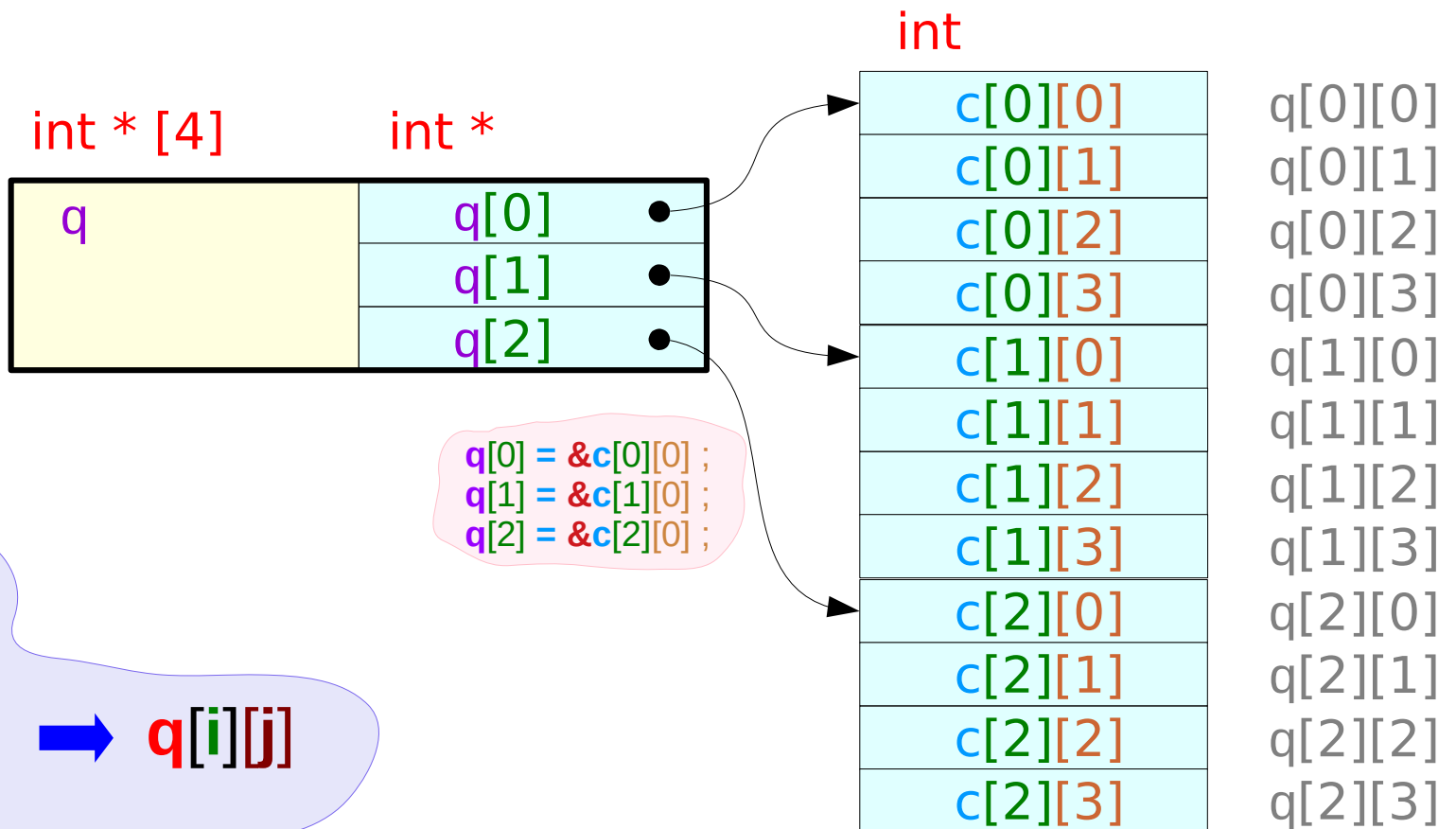

2-d array access using double pointers q

```
int c [3] [4];
```

```
int **p, *q[4];
```

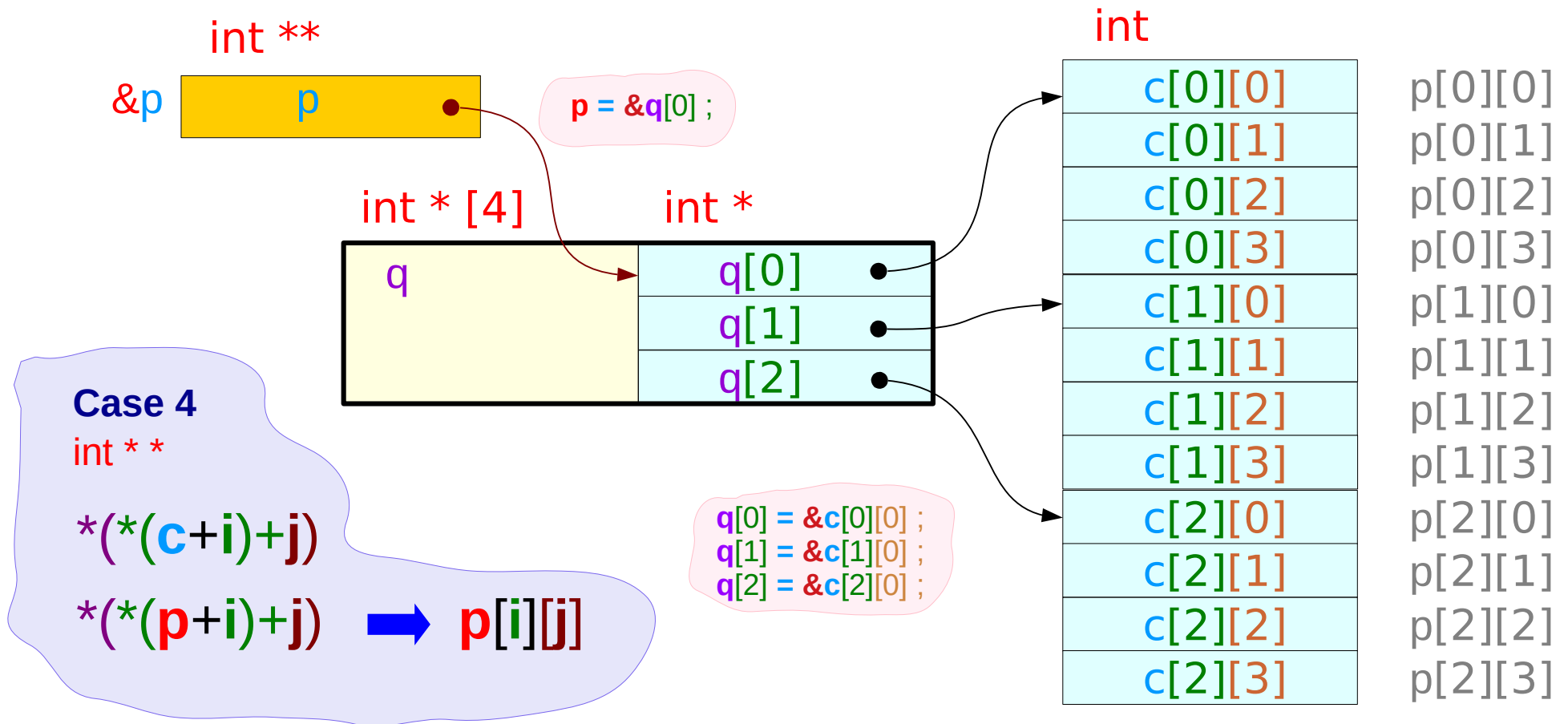

A Linear Memory Address

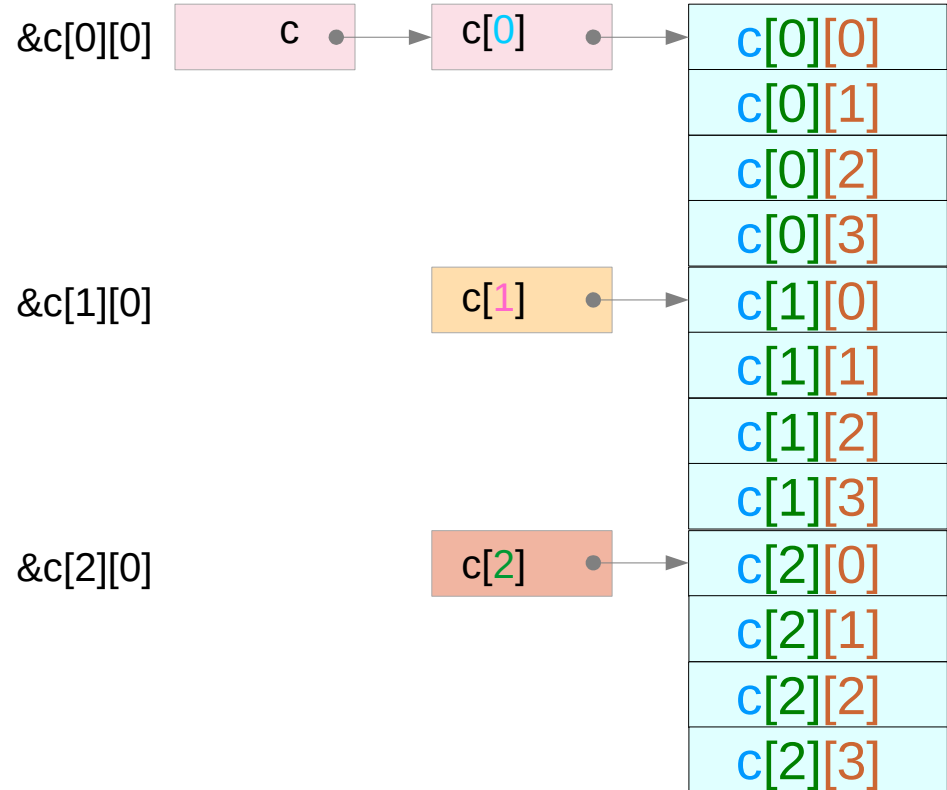
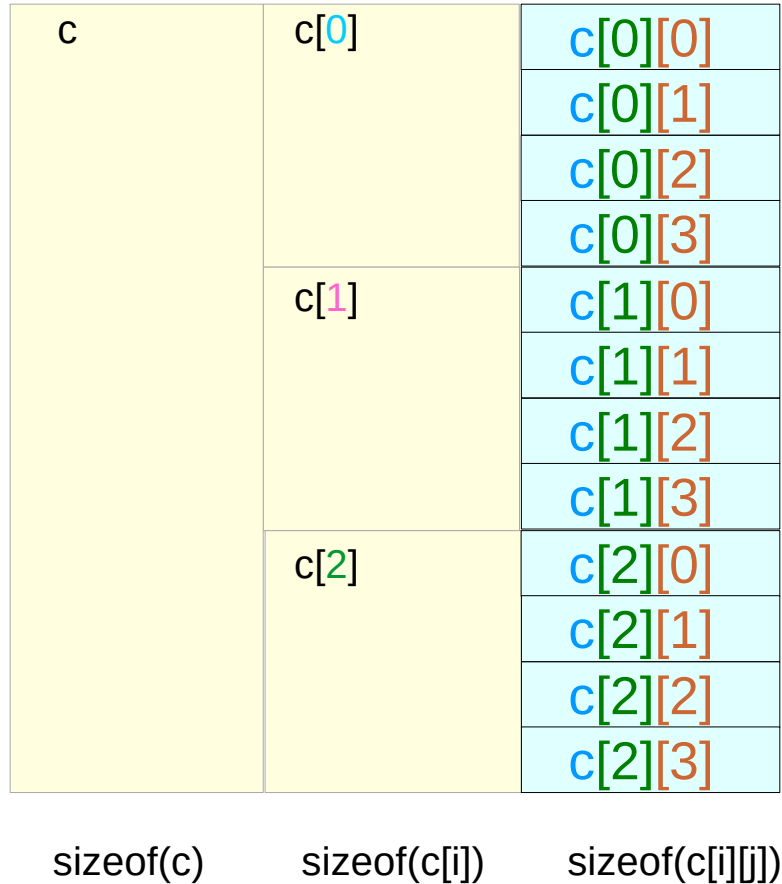

A 2-d array stored as a 1-d array (row major order)

```
int c [3] [4];
```

```
c[i][j]
```

$$[i*4+j]$$

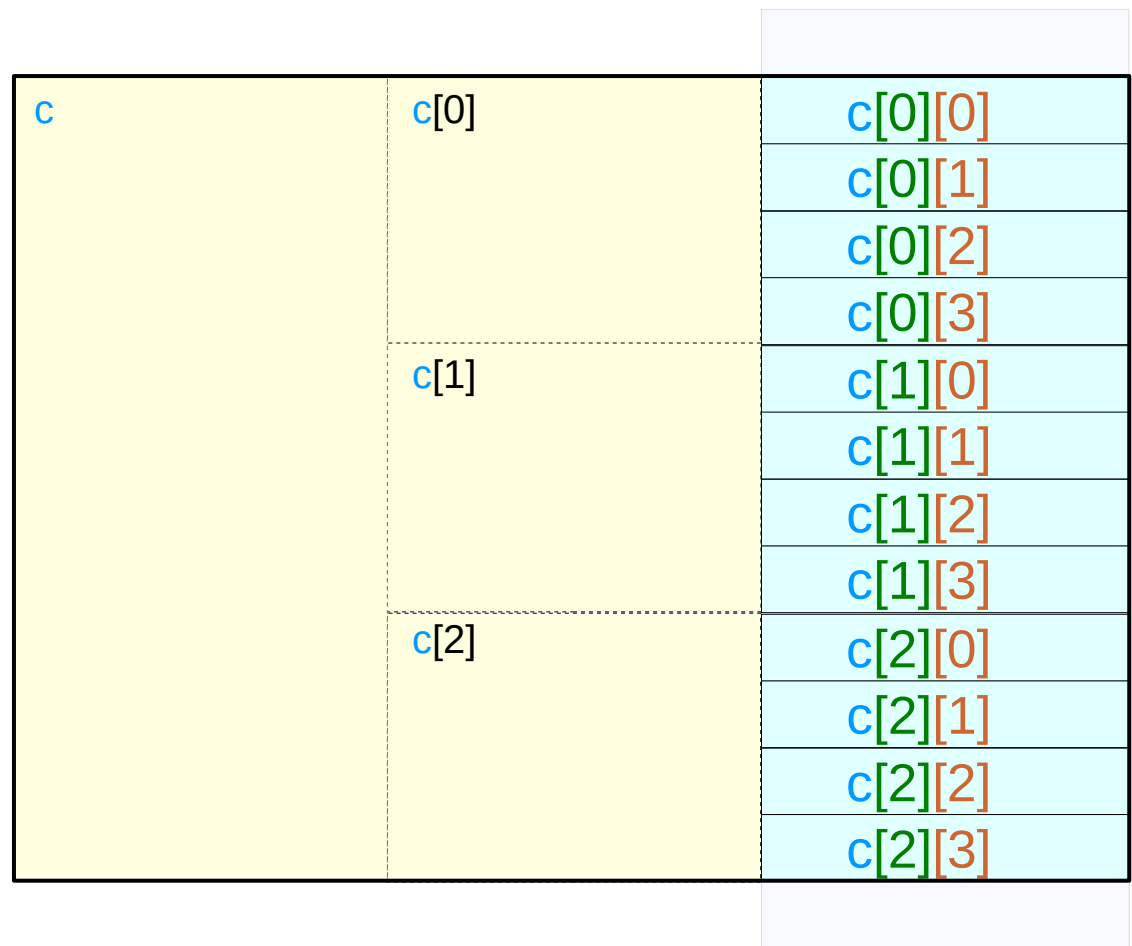

index values

0	= [0*4+0]
1	= [0*4+1]
2	= [0*4+2]
3	= [0*4+3]
4	= [1*4+0]
5	= [1*4+1]
6	= [1*4+2]
7	= [1*4+3]
8	= [2*4+0]
9	= [2*4+1]
10	= [2*4+2]
11	= [2*4+3]

A 2-d array stored as a 1-d array (row major order)

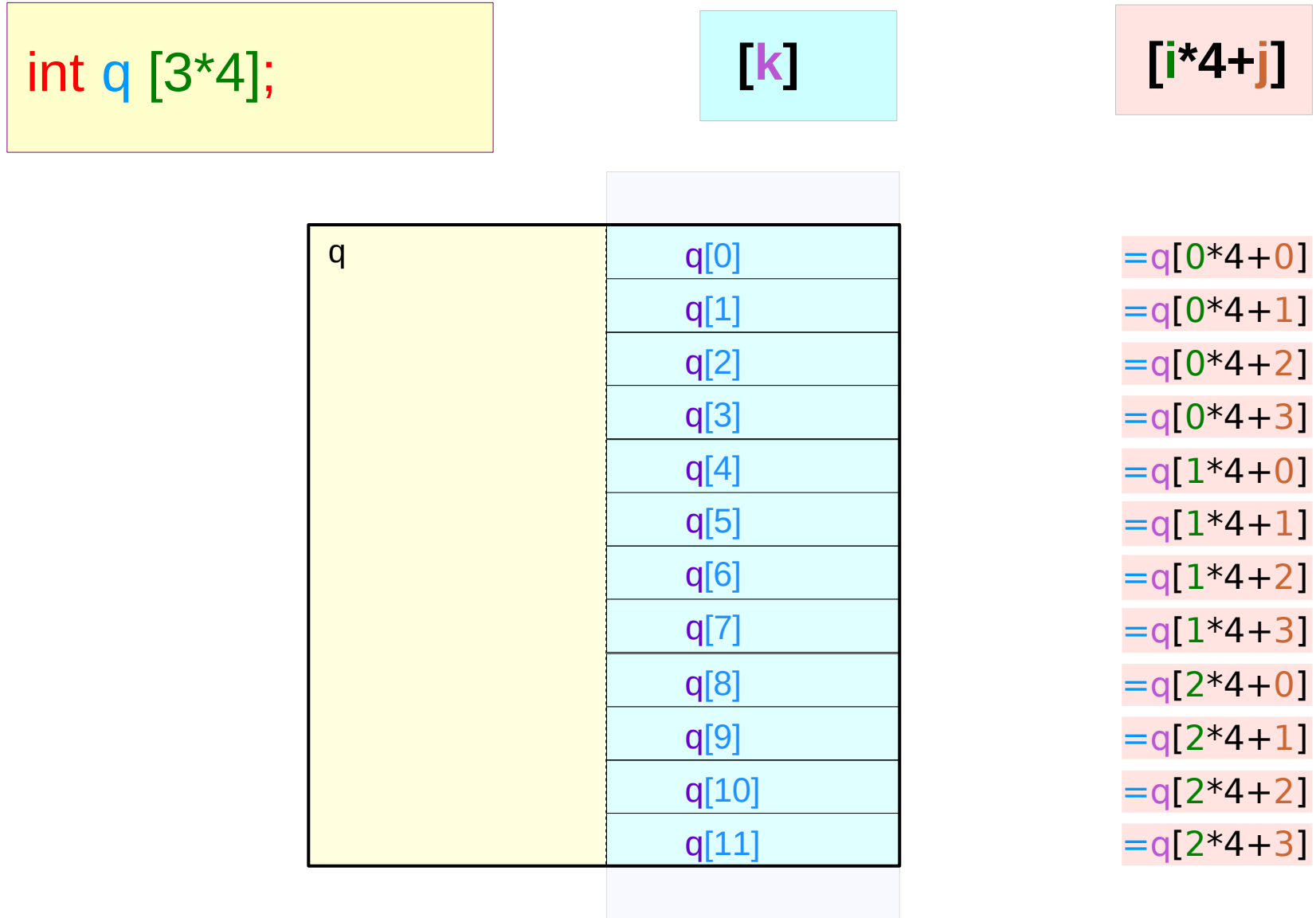

2-d and 1-d interpretations of linear memory

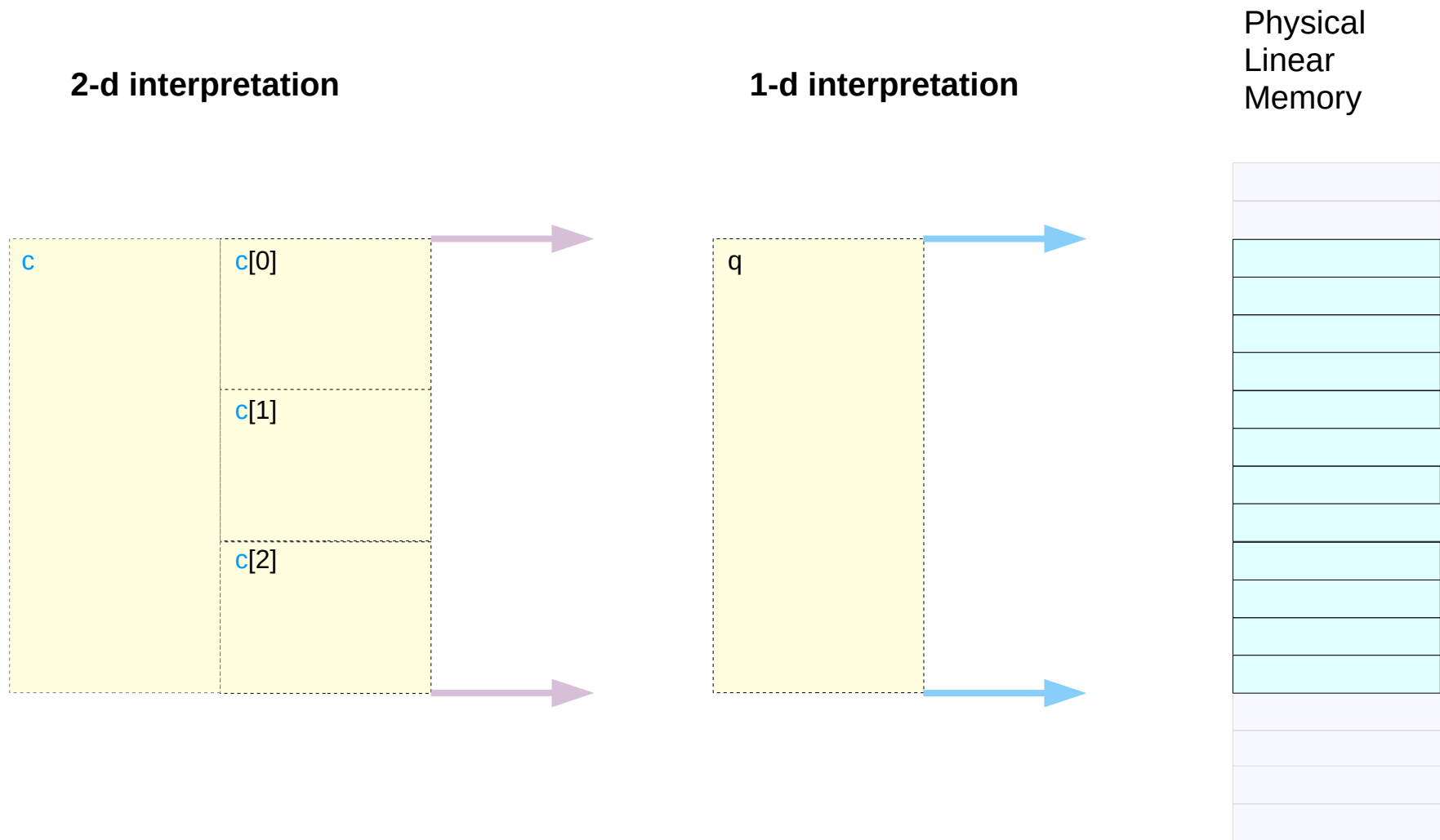

A 2-d array stored as a 1-d array (row major order)

```
int c [3] [4];
```

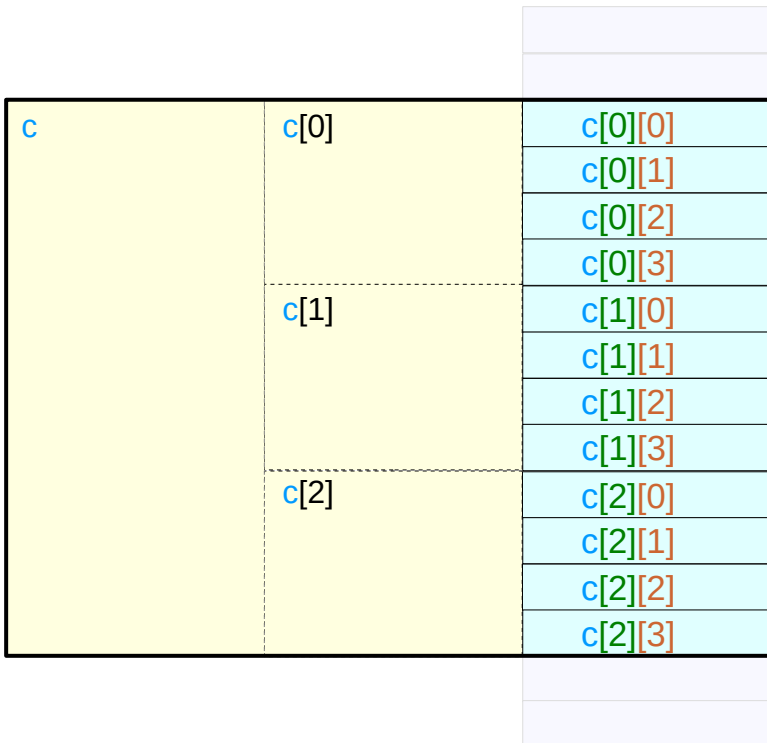

```
int q [3*4];
```

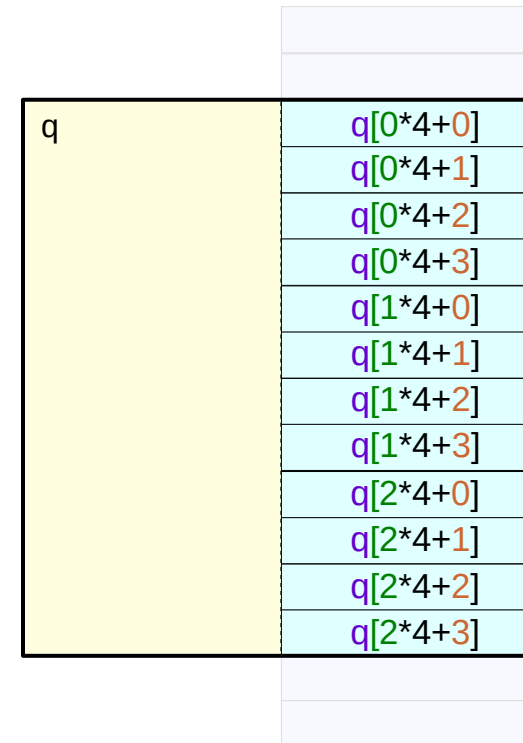

`sizeof(c) = sizeof(c[i]) * 4`

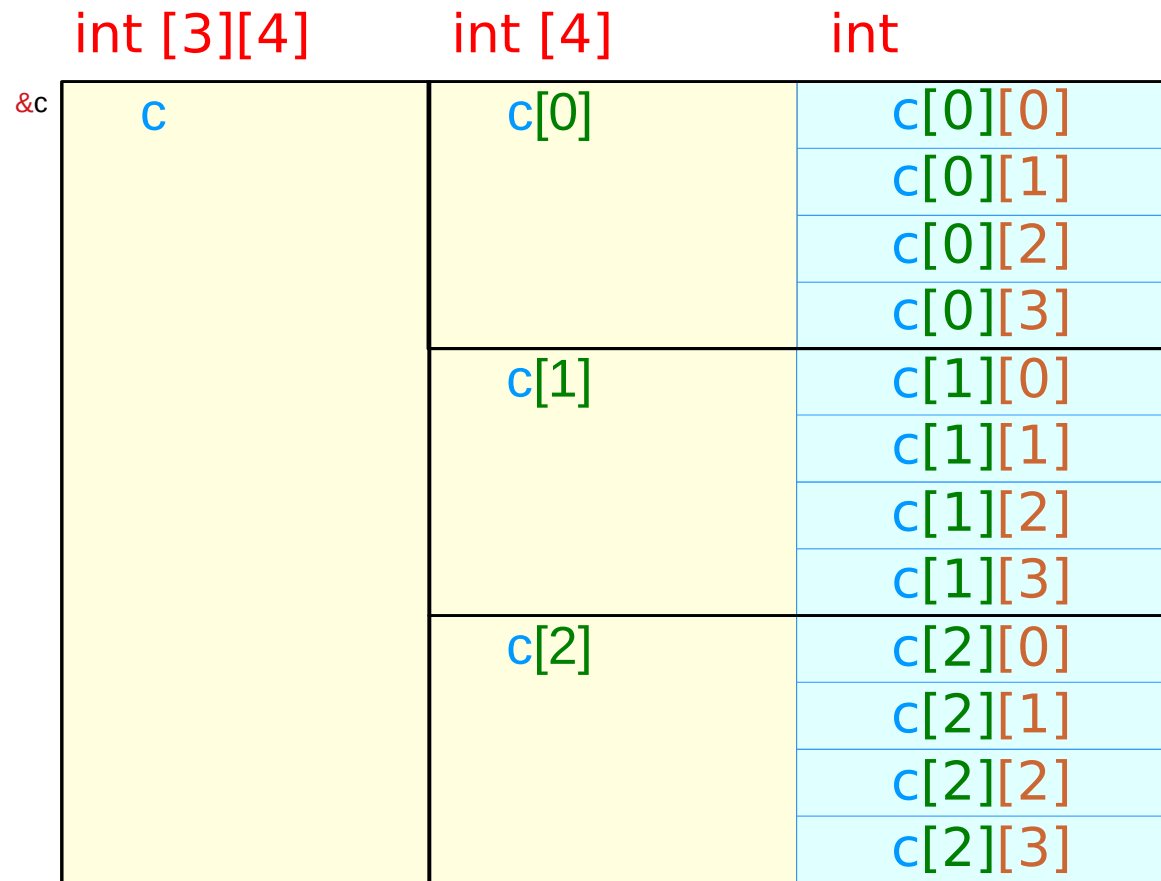

A Linear Memory Address

```
int c[3][4];
```

```
sizeof(c)
```

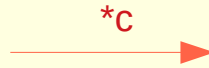

```
int c[3][4];
```

```
sizeof(c[0]) * 3
```

```
int c[3][4];
```

```
sizeof(c[0])
```

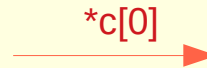

```
int c[3][4];
```

```
sizeof(c[0][0]) * 4
```

```
sizeof(c)
```

```
sizeof(c[0]) * 3
```

```
sizeof(c[0][0]) * 3 * 4
```

```

c = c[0] = &c[0][0]
c[1] = &c[1][0]
c[2] = &c[2][0]
c[3] = &c[3][0]

```

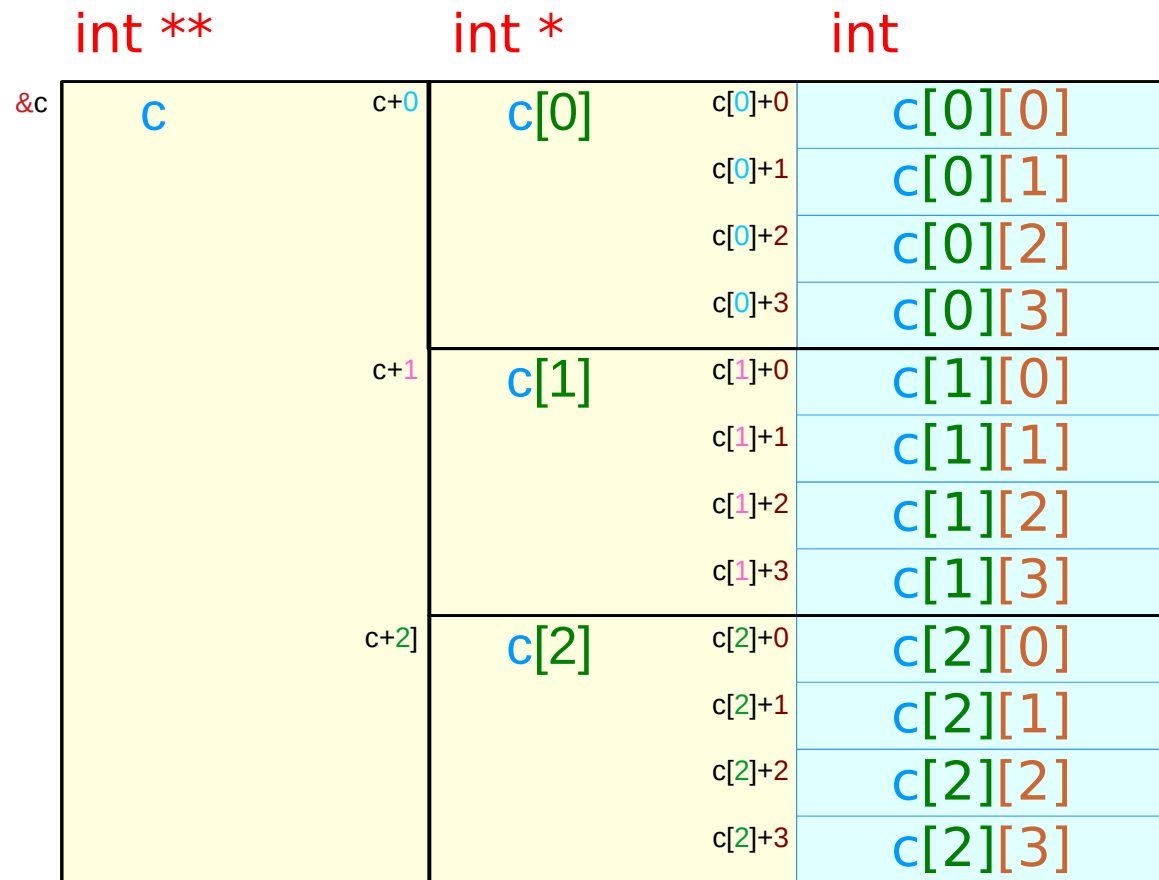

A 2-d array stored as a 1-d array (row major order)

```
int q [4*4];
```

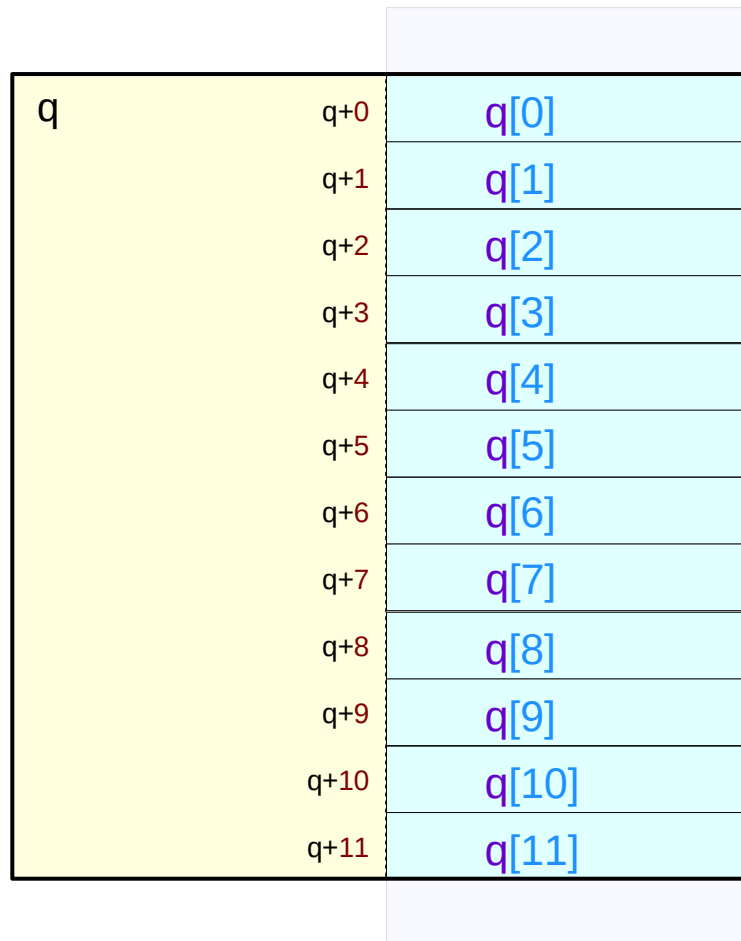

A linearization of a 2-D array

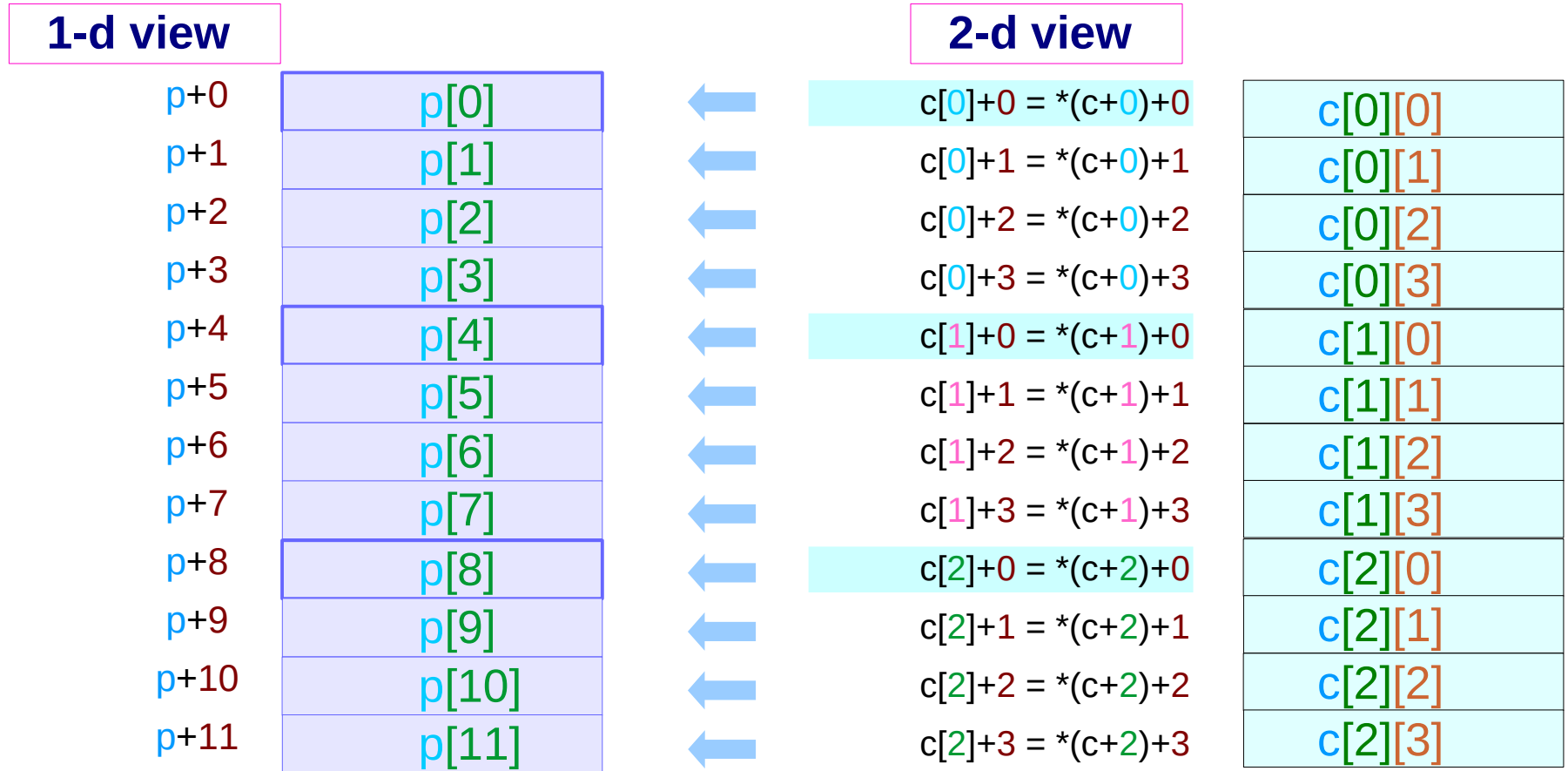

2-d array access via a single pointer

```
int *p = c[0];
```



```
int c [3][4];
```

```
p[ i*4 + j ]
```



```
c[ i ][ j ]
```

```
*(p + i*4 + j)
```



```
*(*(c+i) + j)
```

```
*(p + k)    i = k / 4;  
            j = k % 4;
```

A 2-d array stored as a 1-d array (row major order)

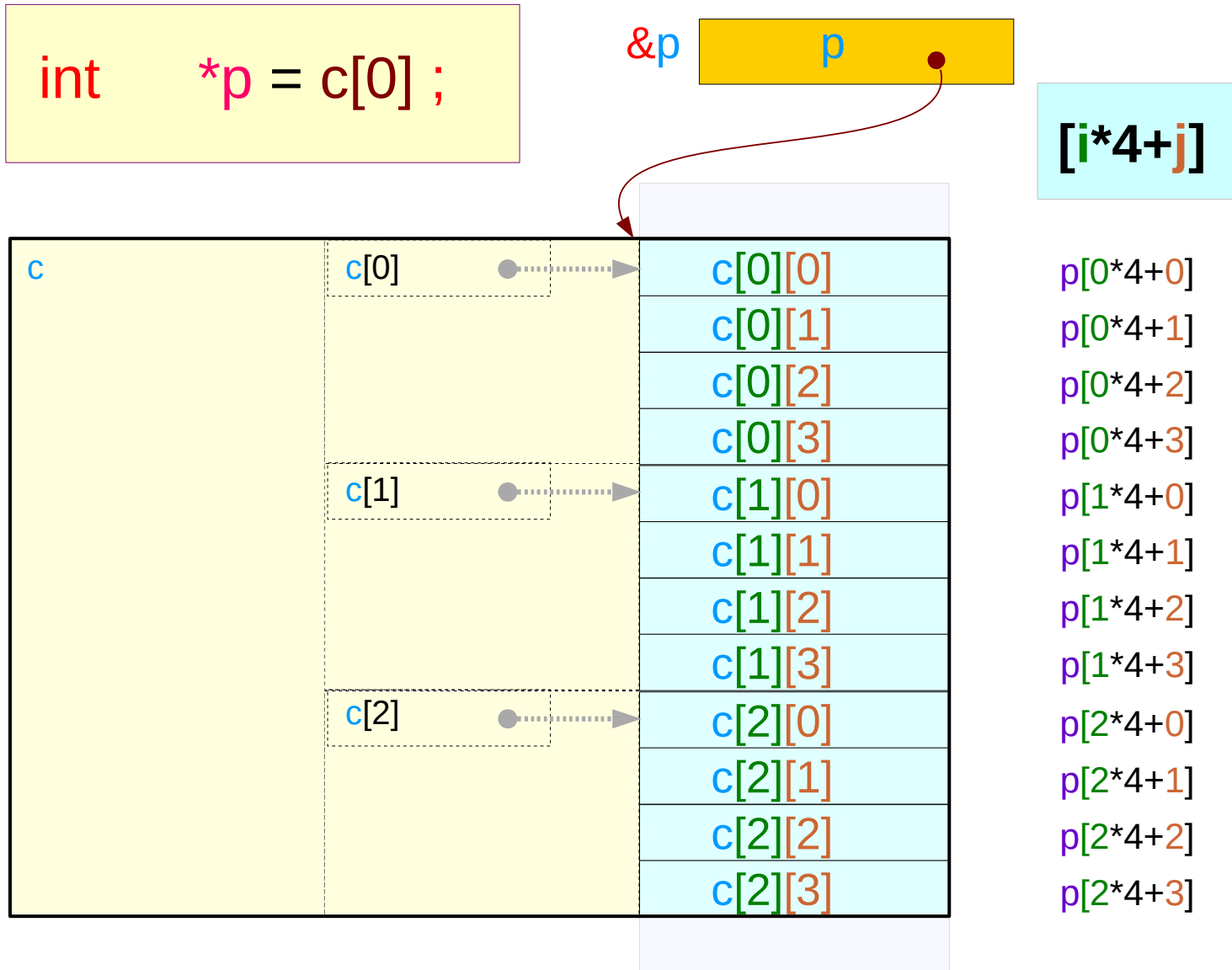

2-d array index vs 1-d array index

```
int c [3] [4];
```

```
int *p=c[0];
```

```
c[i][j]
```

```
p[i*4+j]
```

c[0]	c[0][0]
	c[0][1]
	c[0][2]
	c[0][3]
c[1]	c[1][0]
	c[1][1]
	c[1][2]
	c[1][3]
c[2]	c[2][0]
	c[2][1]
	c[2][2]
	c[2][3]

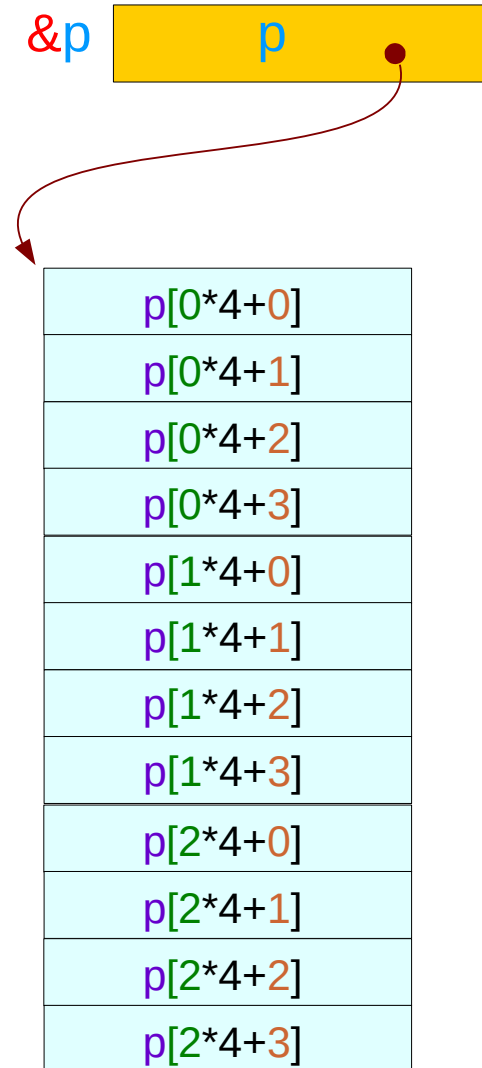

2-d array access via pointers

```
int c [3][4];
```

1. recursive pointers

```
c [ i ][ j ]
```

```
(*(c+i))[ j ]
```

→ int (*p)[4];

```
*(c[ i ]+ j)
```

```
*(*(c+i)+ j)
```

→ int **q;

```
int *p = c[0] ;
```

2. linear array pointers

```
p[ i*4 + j ]
```

```
*(p+ i*4 + j)
```

Static Allocation of a 2-d Array

```
int A [3][4];
```

A in %eax,
i in %edx,
j in %ecx

```
sall    $2, %ecx           ;; j * 4  
leal   (%edx, %edx, 2), %edx  ;; i * 3  
leal   (%ecx, %edx, 4), %edx  ;; j * 4 + i * 12  
movl   (%eax, %edx), %eax    ;; read M[ XA+4(3i +j) ]
```

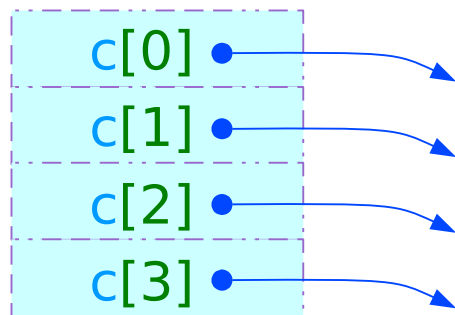

The pointer array :
not allocated
in the memory

c[0]+0	*(c [0]+0)
c[0]+1	*(c [0]+1)
c[0]+2	*(c [0]+2)
c[0]+3	*(c [0]+3)
c[1]+0	*(c [1]+0)
c[1]+1	*(c [1]+1)
c[1]+2	*(c [1]+2)
c[1]+3	*(c [1]+3)
c[2]+0	*(c [2]+0)
c[2]+1	*(c [2]+1)
c[2]+2	*(c [2]+2)
c[2]+3	*(c [2]+3)

Dynamic Memory Allocation of 2-d Arrays

1. method 1

```
int ** c ;  
c = malloc(3 * sizeof (int *) ) ;  
c[0] = malloc(4 * sizeof (int) ) ;  
c[1] = malloc(4 * sizeof (int) ) ;  
c[2] = malloc(4 * sizeof (int) ) ;
```

2. method 2

```
int (*p) [3] ;  
p = malloc(3 * 4 * sizeof (int) ) ;
```

3. method 3

```
int ** c ;  
int * p ;  
c = malloc( 3 * sizeof(int *) ) ;  
p = malloc( 4 * 4 * sizeof(int) ) ;  
for (i=0; i<M; i++) c[i] = p + i*N;
```

2-d array dynamic allocation : method 1 (a)

```
int ** c ;  
  
c = malloc(3 * sizeof (int *)) ;
```

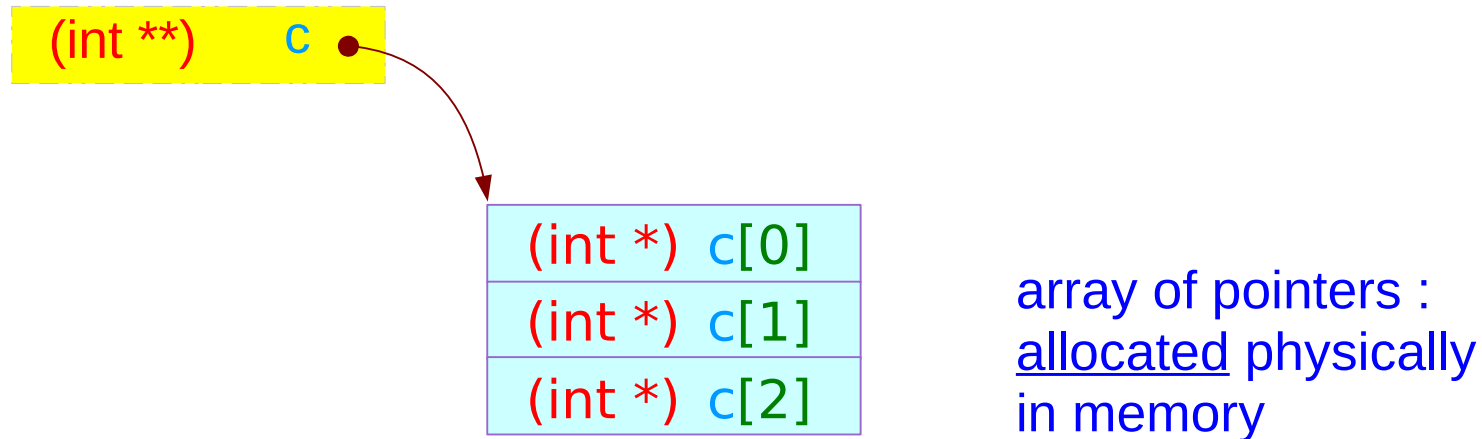

c: an array of
integer pointers

2-d array dynamic allocation : method 1 (b)

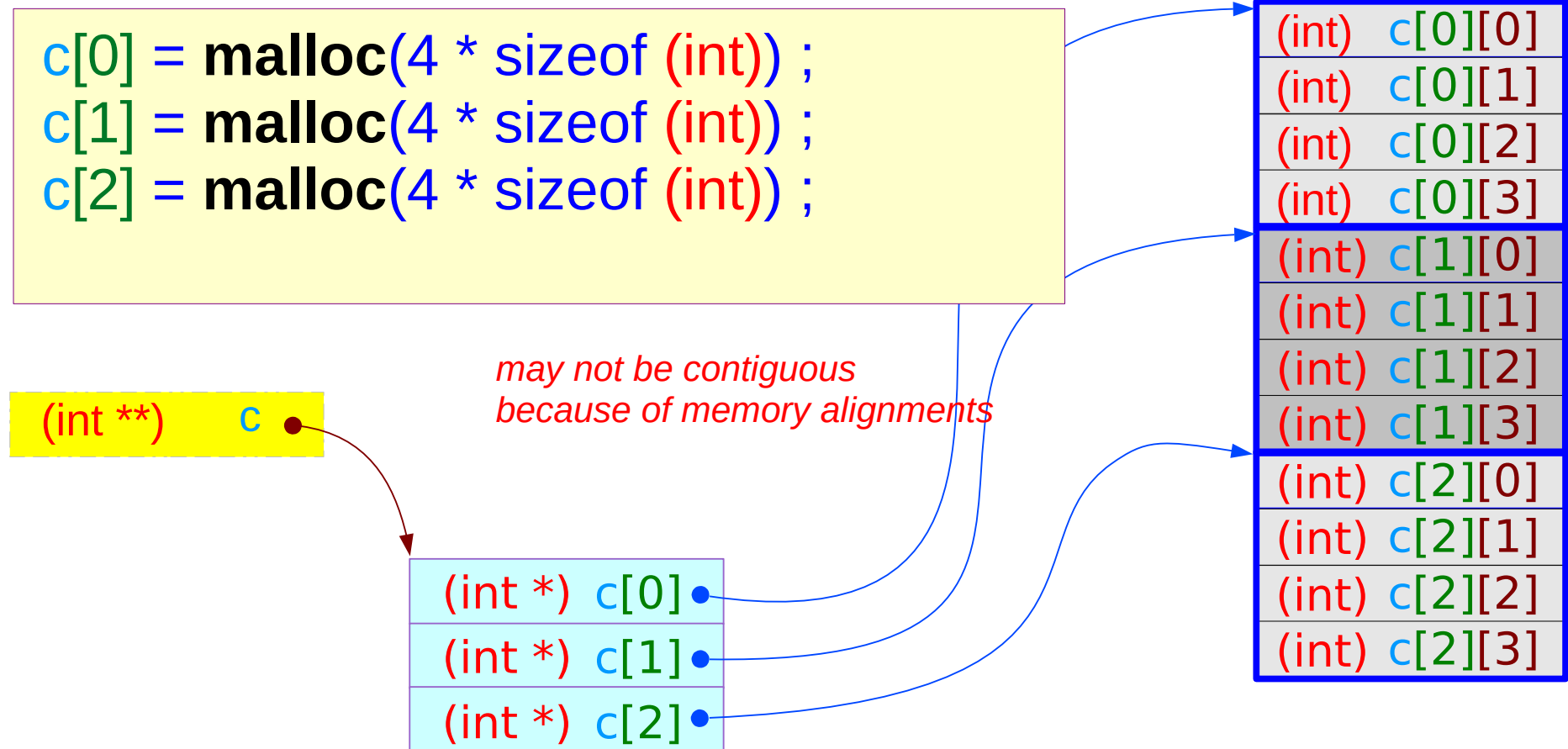

c: an array of
integer pointers

2-d array dynamic allocation : method 2

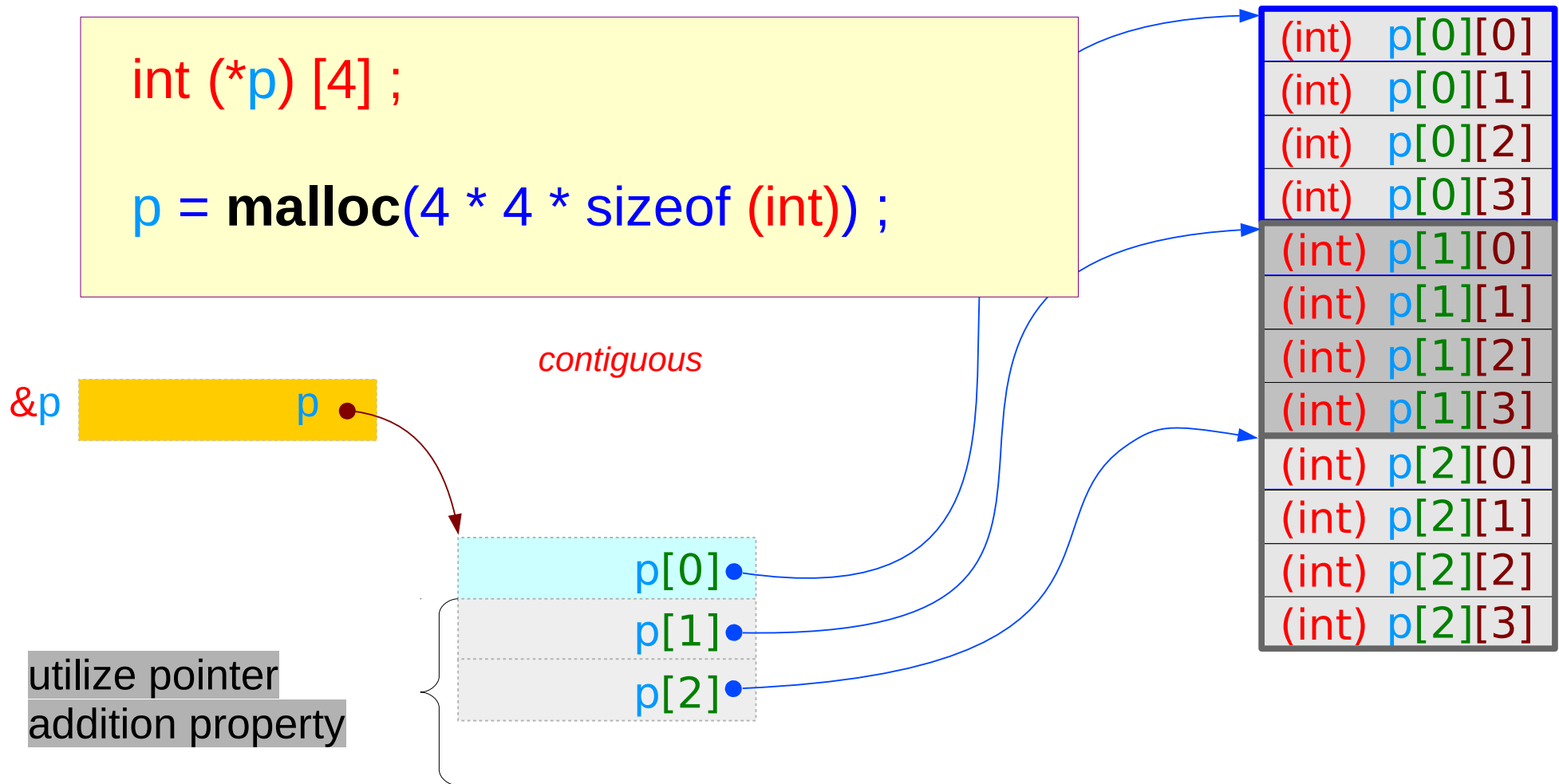

Pointer to Arrays :
No physical allocation

2-d array dynamic allocation : method 3 (a)

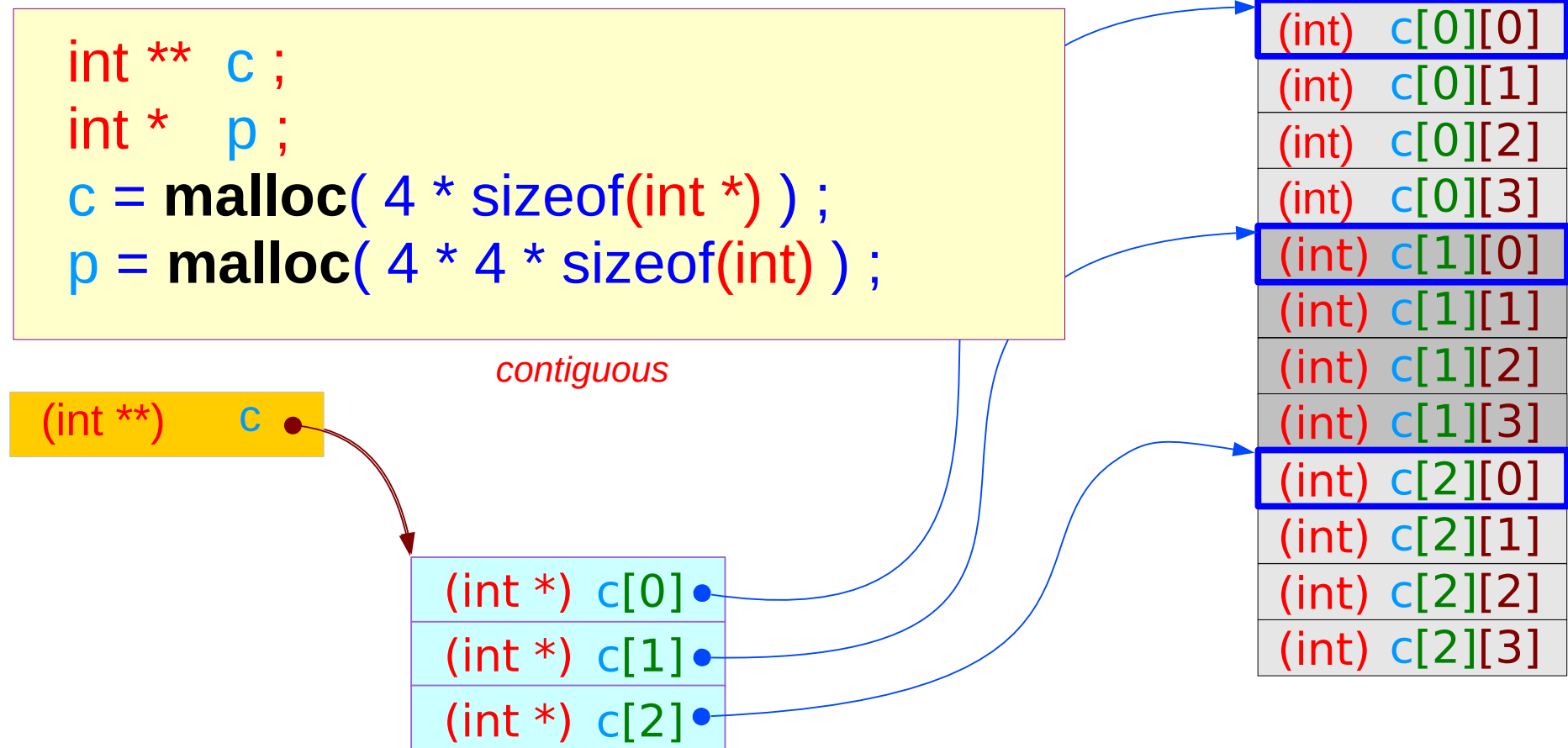

array of pointers
allocated physically in memory

2-d array dynamic allocation : method 3 (b)

```
for (i=0; i<M; i++)  
    c[i] = p + i*N;
```

manual assignments of pointers

(int **) c

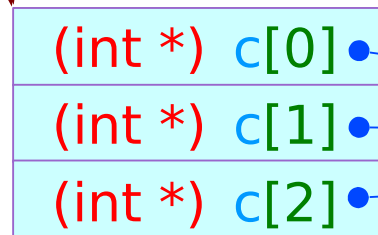

(int *) p

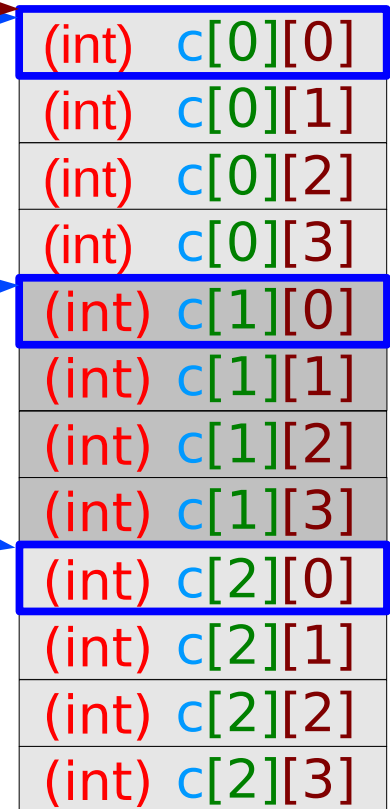

c: an array of integer pointers

Limitations

No index Range Checking

Array Size must be a constant expression

Variable Array Size

Arrays cannot be Copied or Compared

Aggregate Initialization and Global Arrays

Precedence Rule

Index Type Must be Integral

References

- [1] Essential C, Nick Parlante
- [2] Efficient C Programming, Mark A. Weiss
- [3] C A Reference Manual, Samuel P. Harbison & Guy L. Steele Jr.
- [4] C Language Express, I. K. Chun
- [5] <https://pdos.csail.mit.edu/6.828/2008/readings/pointers.pdf>