

# FPGA Carry Chain Adder (1A)

---

- 
-

Copyright (c) 2010 -- 2020 Young W. Lim.

Permission is granted to copy, distribute and/or modify this document under the terms of the GNU Free Documentation License, Version 1.2 or any later version published by the Free Software Foundation; with no Invariant Sections, no Front-Cover Texts, and no Back-Cover Texts. A copy of the license is included in the section entitled "GNU Free Documentation License".

Please send corrections (or suggestions) to [youngwlim@hotmail.com](mailto:youngwlim@hotmail.com).

This document was produced by using OpenOffice and Octave.

# FPGA Carry Chain Cell

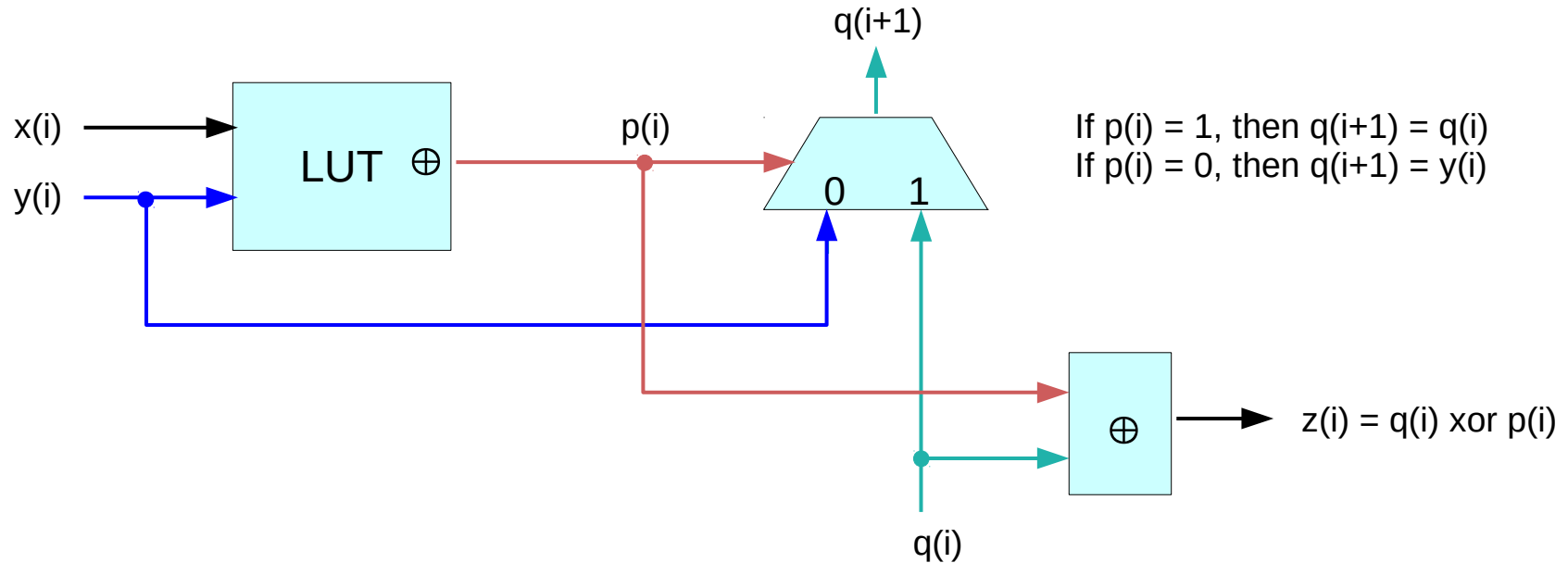

$$s_i = (a_i \oplus b_i) \oplus c_i = p_i \oplus c_i$$

$$c_{i+1} = (a_i \cdot b_i) + (a_i \oplus b_i) c_i = \bar{p}_i \cdot g_i + p_i \cdot c_i = \bar{p}_i \cdot a_i + p_i \cdot c_i = \bar{p}_i \cdot b_i + p_i \cdot c_i$$

when  $\bar{p}_i = 1$ , then  $a_i = b_i$

when  $g_i = 1$ , then  $a_i = b_i = 1$

$p(i)$	0	1
0	0	1
1	1	0

$g(i)$	0	1
0	0	0
1	0	1

# FPGA Carry Chain Cell

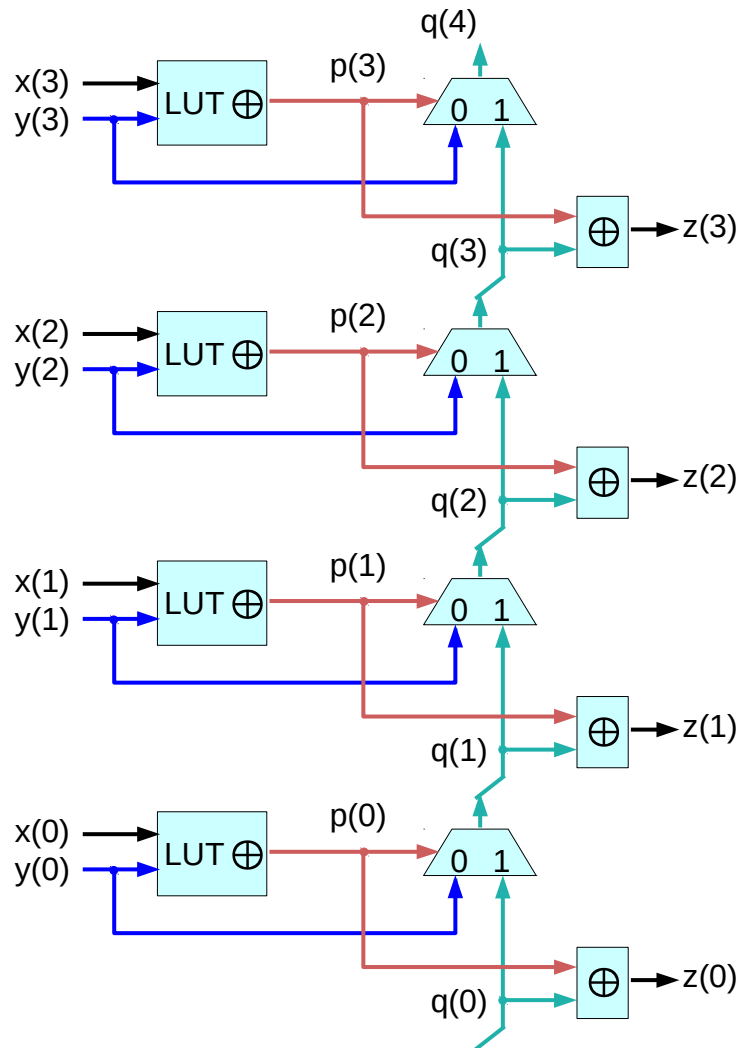

Synthesis of Arithmetic Circuits: FPGA, ASIC and Ebedded Systems, J-P Deschamps et al

# FPGA Carry Chain

FPGAs generally contain dedicated computation resources for generating fast adders

The Virtex family programmable arrays include logic gates (**XOR**) and **multiplexers** that along with the general purpose **lookup tables** allow one to build effective carry-chain adders

The carry chain is made up of multiplexers belonging to adjacent configurable blocks

the lookup table is used for implementing the exclusive or function

$$p(i) = x(i) \text{ xor } y(i)$$

[https://en.wikipedia.org/wiki/Carry-lookahead\\_adder](https://en.wikipedia.org/wiki/Carry-lookahead_adder)

# FPGA Carry Chain Cell

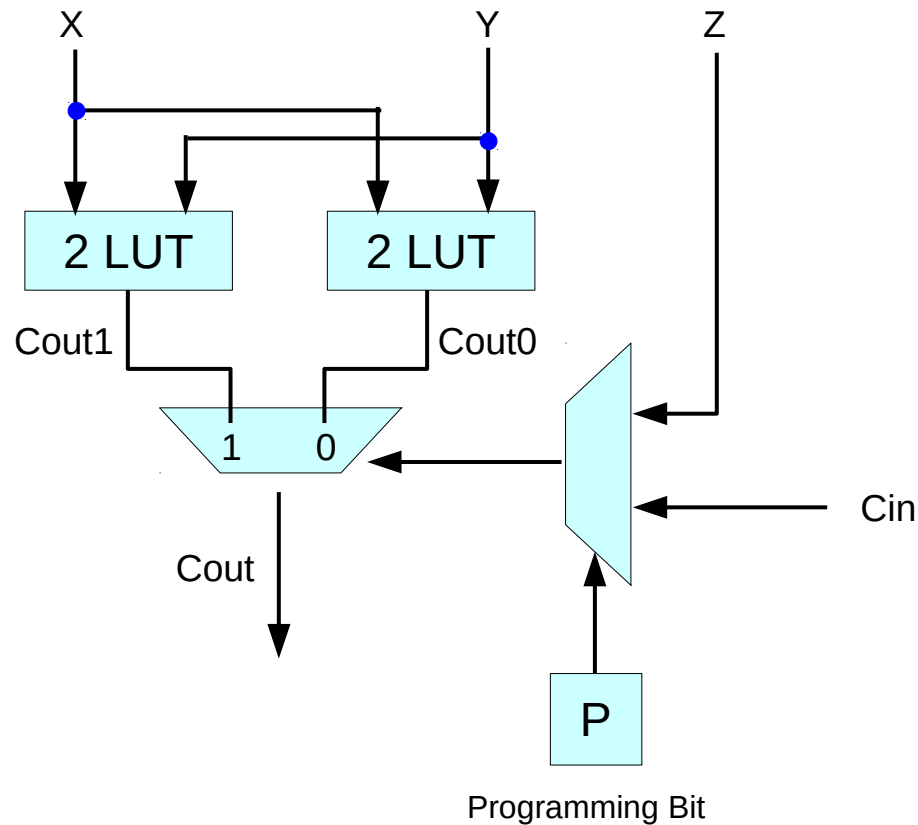

Cout1, Cout2 : functions of X, Y, Cin

Cout1 = X+Y when Cin=1

Cout0 = X Y when Cin=0

Cout = (X + Y) Cin + X Y  $\overline{\text{Cin}}$

Cout = P' Cin + G  $\overline{\text{Cin}}$  ... P' = relaxed P

Cout1	Cout0	Cout	Name
0	0	0	Kill
0	1	$\overline{\text{Cin}}$	Inverse Propagate
1	0	Cin	Propagate
1	1	1	Generate

High Performance Carry Chains for FPGAs, S. Hauck, M. M. Hosler, T. W. Fry

# FPGA Carry Chain Cell

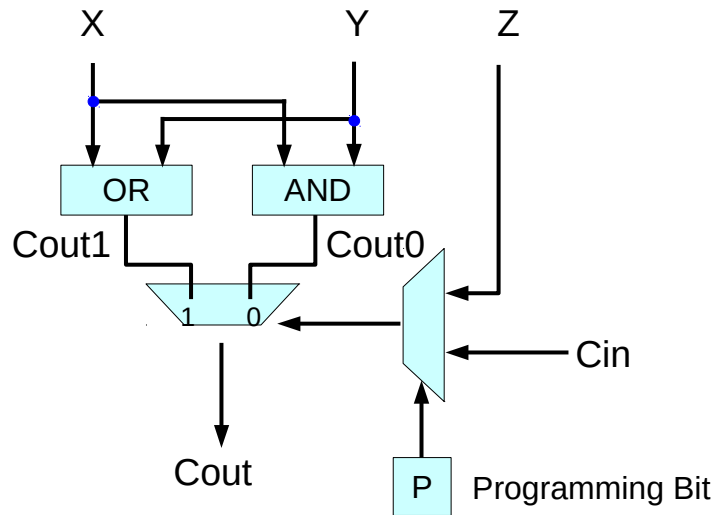

X	Y	Cin	$\overline{\text{Cin}}$	$\overline{X} \overline{Y}$
		Cout1	Cout0	
0	0	0	0	$\overline{X} \overline{Y}$
0	1	1	0	$\overline{X} Y$
1	0	1	0	$X \overline{Y}$
1	1	1	1	$X Y$

Cout : functions of X, Y, Cin

$$\text{Cout}(X, Y, 1) = \text{Cout1} = X + Y$$

$$\text{Cout}(X, Y, 0) = \text{Cout0} = X Y$$

$$\text{Cout1} = X + Y \text{ when Cin}=1$$

$$\text{Cout0} = X Y \text{ when Cin}=0$$

$$\text{Cout1} = P' \text{Cin} \dots P' = \text{relaxed } P$$

$$\text{Cout0} = G \overline{\text{Cin}}$$

$$\text{If Cin, then Cout} = (\overline{X} Y + X \overline{Y} + X Y)$$

$$\text{If } \overline{\text{Cin}}, \text{ then Cout} = X Y$$

$$\text{Cin} (X + Y) + \overline{\text{Cin}} X Y$$

$$\text{Cin} (\overline{X} Y + X \overline{Y} + X Y) + \overline{\text{Cin}} X Y$$

$$\text{Cin} (\overline{X} Y + X \overline{Y}) + (\text{Cin} + \overline{\text{Cin}}) X Y$$

$$P \text{Cin} + G$$

$$\text{Cin} (X + Y) + \overline{\text{Cin}} X Y$$

$$\text{Cin } P' + \overline{\text{Cin}} G$$

$$\dots P' : \text{relaxed } P$$

High Performance Carry Chains for FPGAs, S. Hauck, M. M. Hosler, T. W. Fry

# FPGA Carry Chain Cell

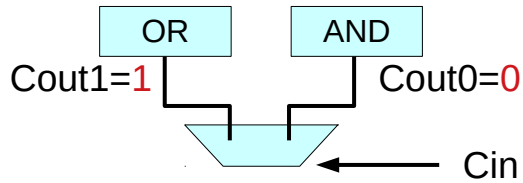

$Cout1=1$  when  $Cin=1$   
 $Cout0=0$  when  $Cin=0$   
 $Cout = Cin$

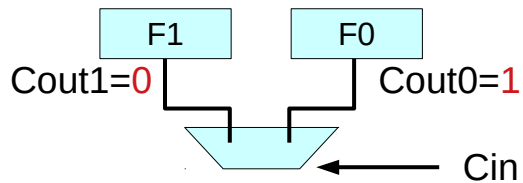

$Cout1=0$  when  $Cin=1$   
 $Cout0=1$  when  $Cin=0$   
 $Cout = \overline{Cin}$

Cout0	Cout1	Cout	Name
0	0	0	Kill
0	1	$\overline{Cin}$	Propagate
1	0	$Cin$	Inverse Propagate
1	1	1	Generate

Cout1	Cout0	Cout	Name
0	0	0	Kill
0	1	$\overline{Cin}$	Inverse Propagate
1	0	$Cin$	Propagate
1	1	1	Generate

High Performance Carry Chains for FPGAs, S. Hauck, M. M. Hosler, T. W. Fry



# Carry Chain

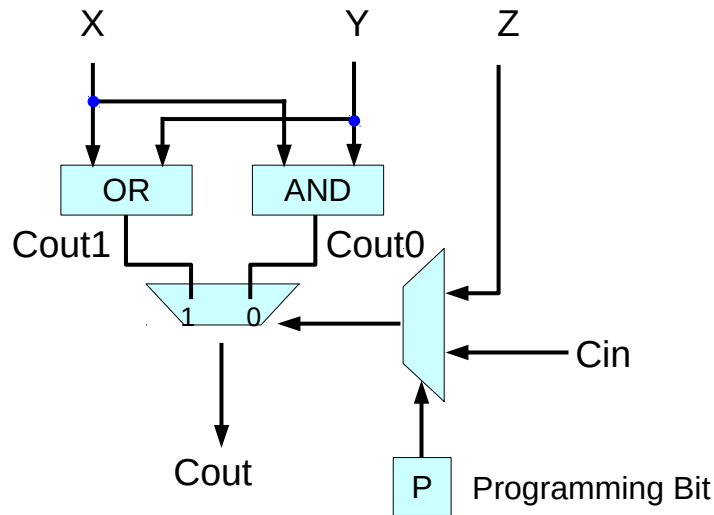

Carry Out

X	Y	Cin	Cout
0	0	Cin	$\overline{\text{Cin}}$
0	1	Cin	$\overline{\text{Cin}}$
1	0	Cin	$\overline{\text{Cin}}$
1	1	Cin	Cin

X	Y	Cin	$\overline{\text{Cin}}$	$\overline{\text{X}} \overline{\text{Y}}$
		Cout1	Cout0	
0	0	0	0	$\overline{\text{X}} \overline{\text{Y}}$
0	1	1	0	$\overline{\text{X}} \text{Y}$
1	0	1	0	$\text{X} \overline{\text{Y}}$
1	1	1	1	$\text{X} \text{Y}$

Cout1	Cout0	Cout	Name
0	0	0	Kill
0	1	$\overline{\text{Cin}}$	Inverse Propagate
1	0	Cin	Propagate
1	1	1	Generate

Cout1=1 when Cin=1

Cout0=0 when Cin=0

Cout = Cin      propagate

Cout1=0 when Cin=1

Cout0=1 when Cin=0

Cout =  $\overline{\text{Cin}}$       inverse propagate

# Parity Checker

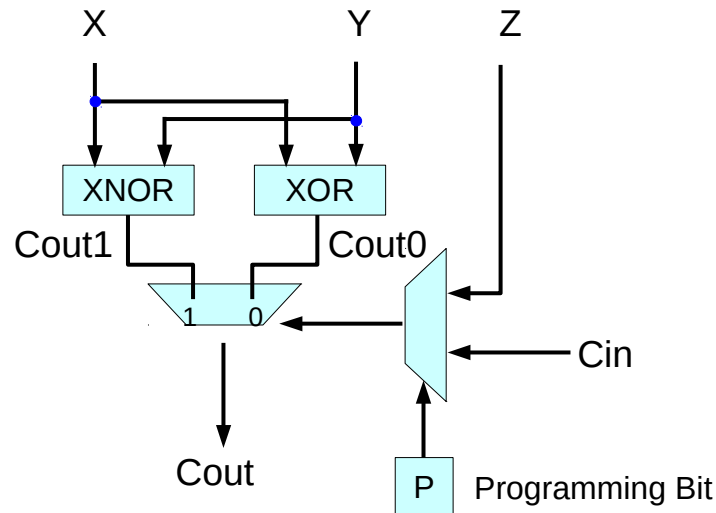

X	Y	Cin	$\overline{\text{Cin}}$	
		Cout1	Cout0	
0	0	1	0	$\overline{X} \overline{Y}$
0	1	0	1	$\overline{X} Y$
1	0	0	1	$X \overline{Y}$
1	1	1	0	$X Y$

Cout1	Cout0	Cout	Name
0	0	0	Kill
0	1	$\overline{\text{Cin}}$	Inverse Propagate
1	0	Cin	Propagate
1	1	1	Generate

## Computing Parity

$X \oplus Y \oplus \text{Cin}$	
$0 \oplus 0 \oplus \text{Cin}$	$\overline{\text{Cin}}$
$0 \oplus 1 \oplus \text{Cin}$	$\overline{\text{Cin}}$
$1 \oplus 0 \oplus \text{Cin}$	$\overline{\text{Cin}}$
$1 \oplus 1 \oplus \text{Cin}$	Cin

Cout1=1 when Cin=1

Cout0=0 when Cin=0

Cout = Cin propagate

Cout1=0 when Cin=1

Cout0=1 when Cin=0

Cout =  $\overline{\text{Cin}}$  inverse propagate

# Ripple Carry Chain

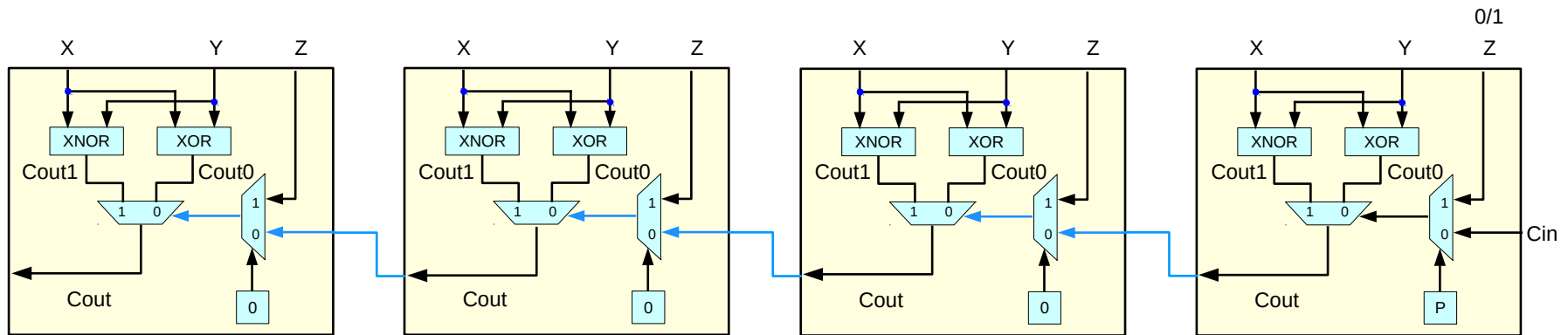

the **first cell** in the chain

High Performance Carry Chains for FPGAs, S. Hauck, M. M. Hosler, T. W. Fry

# FPGA Carry Chain Cell

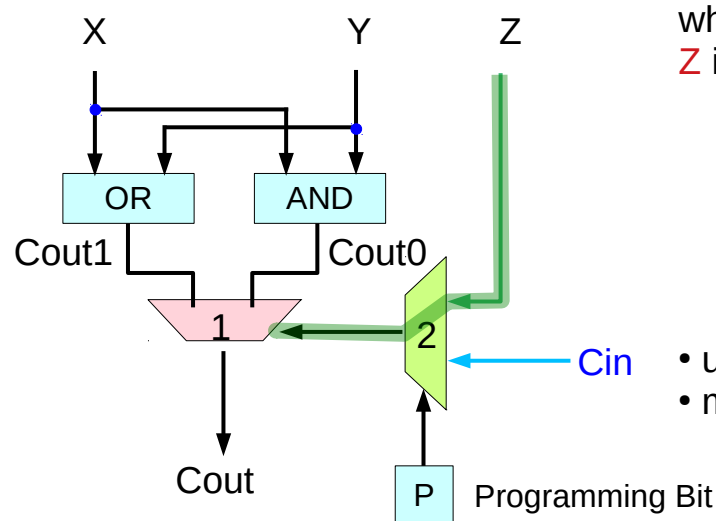

when Cin is ignored,  
Z is routed to mux1

- used in **combined adder/subtractors**
- must be ignored, otherwise

the logic cells - resources to compute a function  
the exact location of logic cells depends on the user.  
a user can start or end a carry computation  
at any place in an fpga.

But in many carry computations,  
the first cell has only 2 inputs,  
and forcing the carry chain  
to wait for the arrival of an additional,  
unnecessary input Z will only needlessly  
slow down the circuit's computation.

High Performance Carry Chains for FPGAs, S. Hauck, M. M. Hosler, T. W. Fry

# FPGA Carry Chain Cell

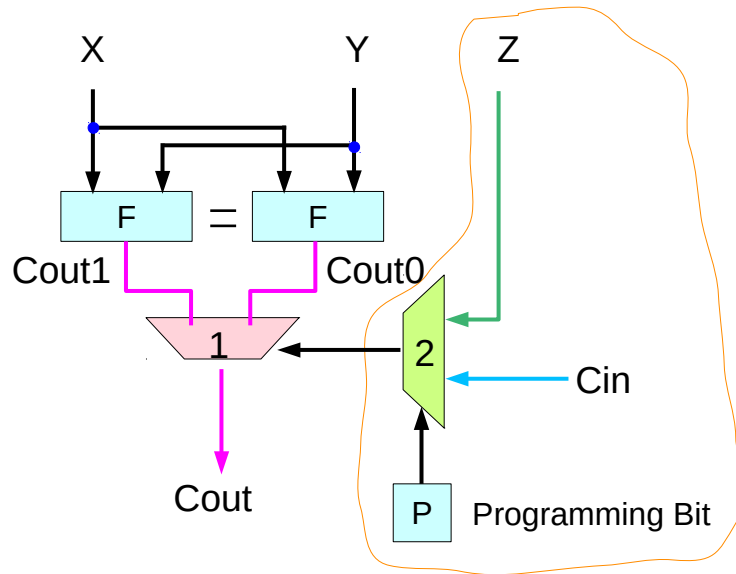

when **Cin** is ignored,  
**Z** can also be ignored  
by having the same LUTs

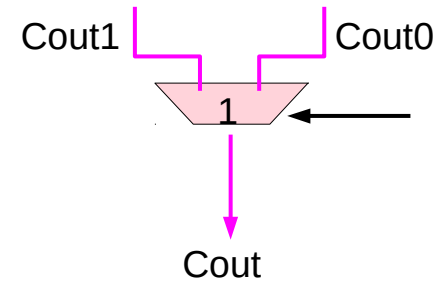

the **first cell** in the chain

the same LUTs

the same output  
regardless of **Z** and **Cin**

$Cout1 = Cout0 = Cout$   
regardless of the select

# Ripple Carry Chain

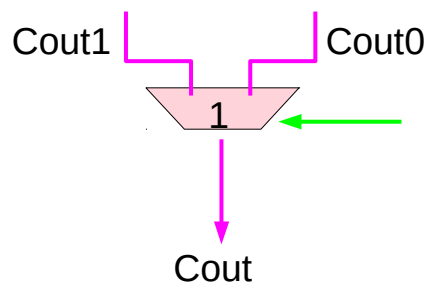
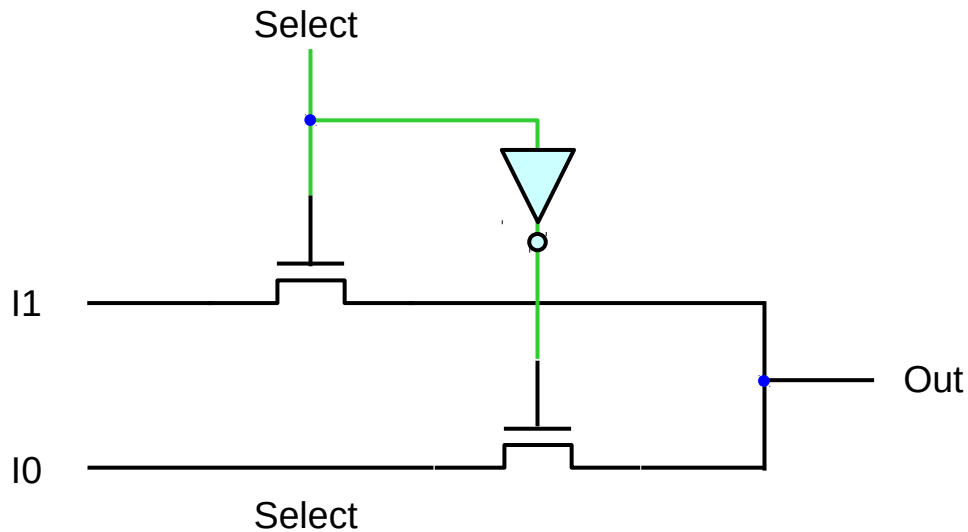

fig1b shows an implementation of a mux that does not obey this requirement

since the carry chain is part of an fpga, the input to this mux could be connected to some **unused logic** in another row which is generating **unknown values**.

if that unused logic had **multiple transitions** which caused the signal to change **quicker** than the gate could react, then it is possible that **the select signal** to this mux could be stuck midway between true and false (2.5V for 5V CMOS)

in this case, it will not be able to pass a true value from the input to the output and thus will not function properly for this application.

# Ripple Carry Chain

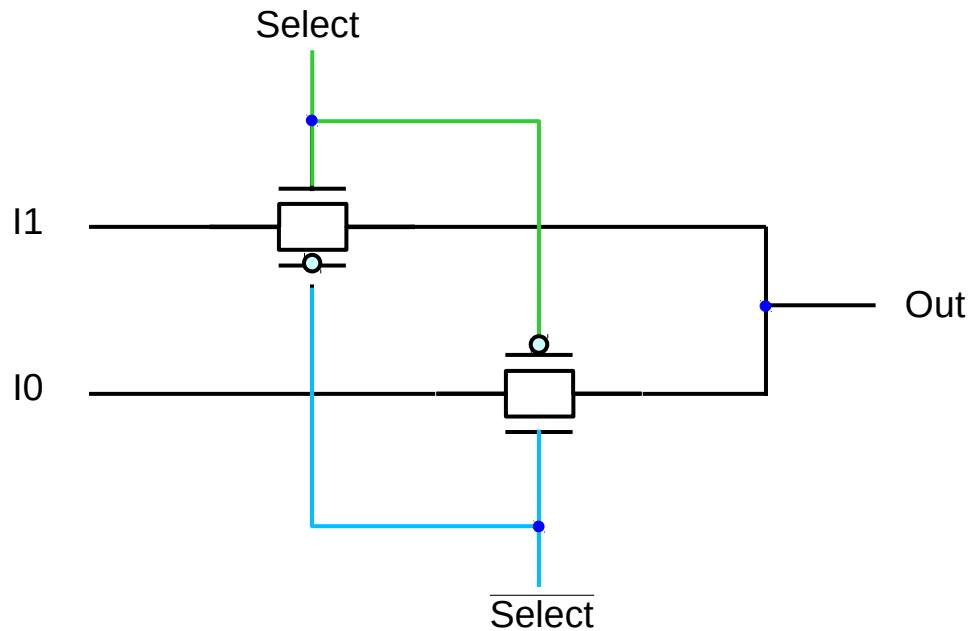

however a mux built with both n-transistor and p-transistor pass gates will operate properly for this case

assume this mux implementation will be used

tristate driver based muxes could be used, which restore signal drive and cut series RC chains

# Unit Gate Delay Model

All simple gate of two or three inputs that are directly implementable in **one logic level** in CMOS are considered to have a **delay of one**.

All other gate must be implemented by such gates, and have the delay of the underlying circuit.

## Delay of one

- inverters and
- 2 to 3 input NAND
- 2 to 3 input NOR gates

A **2:1 mux** has a **delay of one** from the I0 or I1 inputs to the output, But has a **delay of two** from the select input to the output due to the Inverter delay

## Delay of zero (constant delay)

- the delay of the 2-LUTs,
- any routing leading to them,

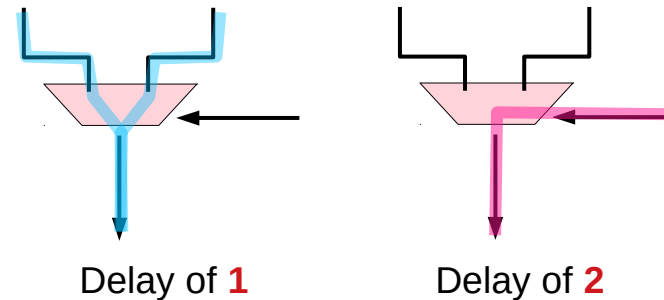
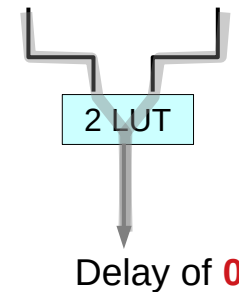



# FPGA Carry Chain Cell

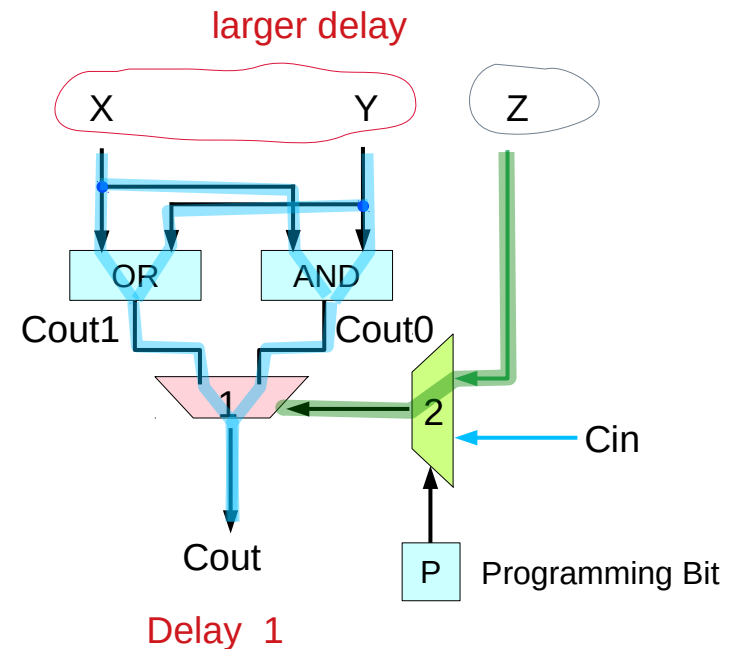
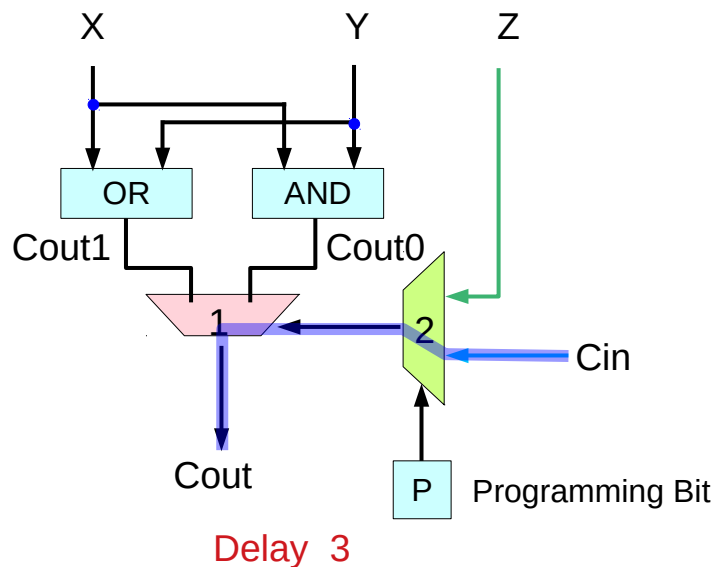

Significantly slower  
**two muxes** on the carry chain in each cell

Delay **1** for first cell  
Delay **3** for each additional cell in the carry chain  
delay **1** for mux2  
delays **2** for mux1

Overall  $3n-2$  for an n-cell carry chain

The critical path comes from the 2-LUTs  
and not from the input Z  
since the delay through the 2-LUTs  
will be larger than through mux 2 in the first cell

# FPGA Carry Chain Cell

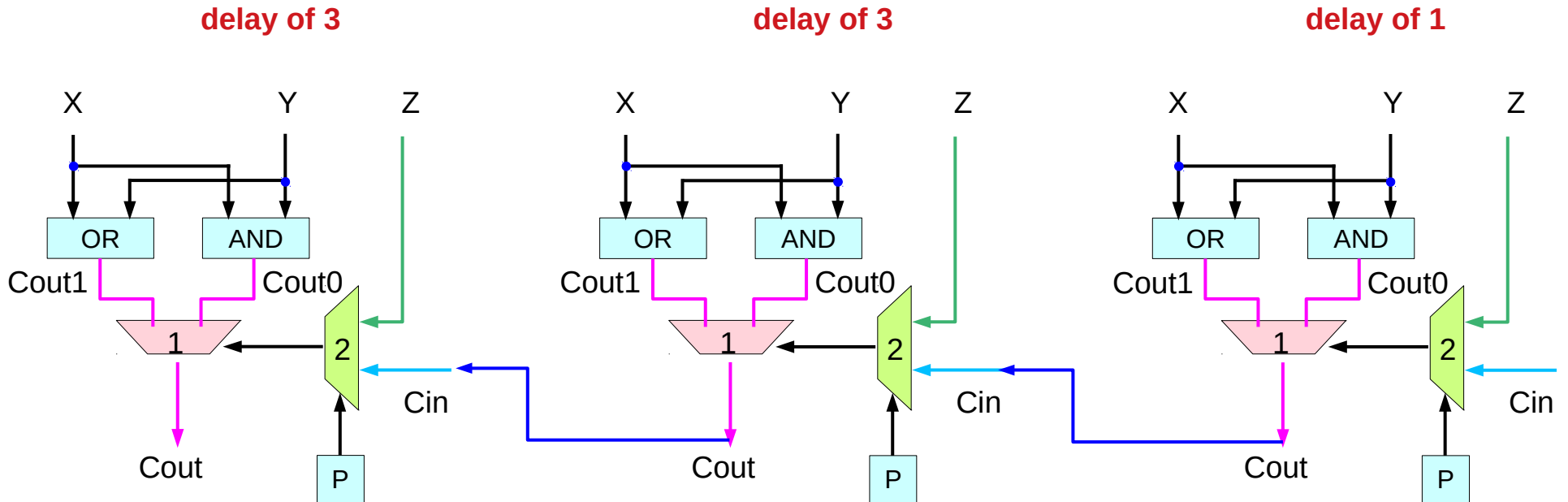

**delay of  $3n-2$**  for an  $n$ -bit ripple carry chain

High Performance Carry Chains for FPGAs, S. Hauck, M. M. Hosler, T. W. Fry

# FPGA Carry Chain Cell

to optimize a ripple carry chain structure for use in FPGAs  
while this provides some performance gain over the basis ripple carry scheme  
found in many current FPGAs, it is still much slower than what is done in custom logic  
There have been tremendous amounts of work done on developing alternative  
carry chain scheme that overcome the linear delay growth of ripple carry adders  
Although these techniques have not yet been applied to FPGAs,  
demonstrate how these advanced adder techniques can be integrated into reconfigurable logic

High Performance Carry Chains for FPGAs, S. Hauck, M. M. Hosler, T. W. Fry

# Design A

to reduce the delay of the ripple carry chain

- remove **mux2** from the carry path.
- no need to choose between **Cin** and **Z** for the select line to the output **mux1**

- two separate muxes, **mux1** and **mux2**, controlled by **Cin** and **Z**, respectively.
- the circuit chooses between these outputs with **mux3**.

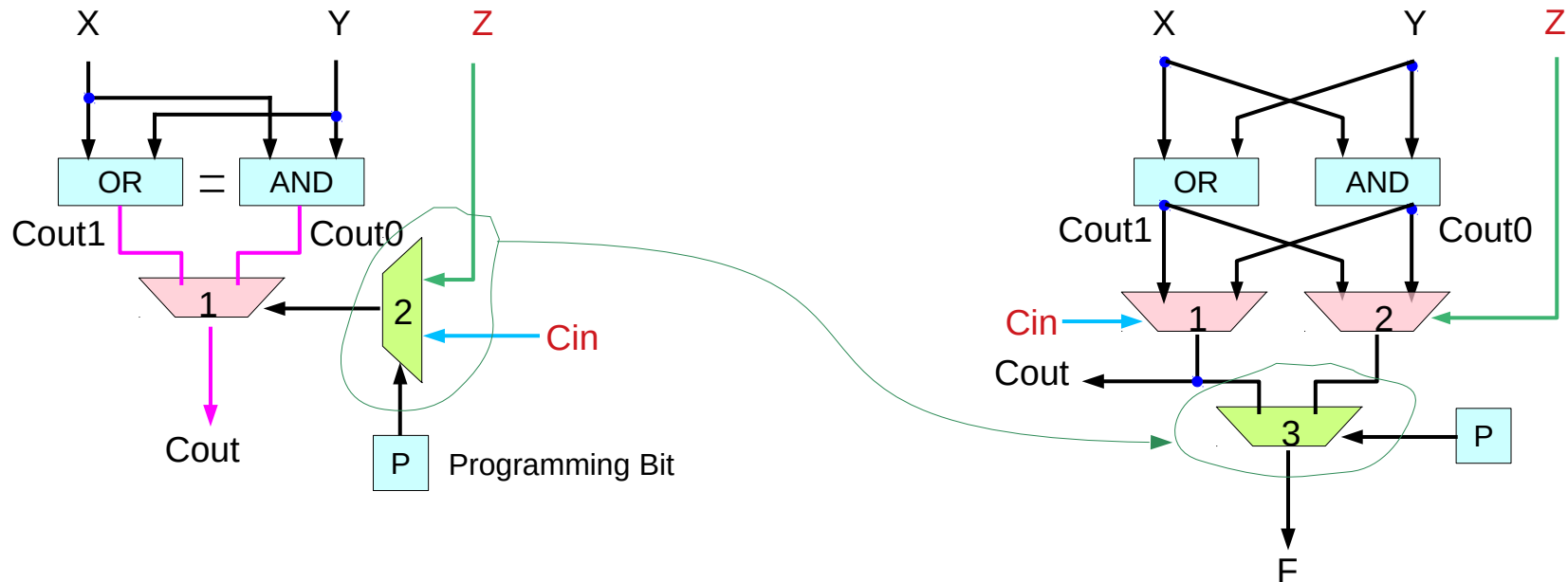

High Performance Carry Chains for FPGAs, S. Hauck, M. M. Hosler, T. W. Fry

# Design A

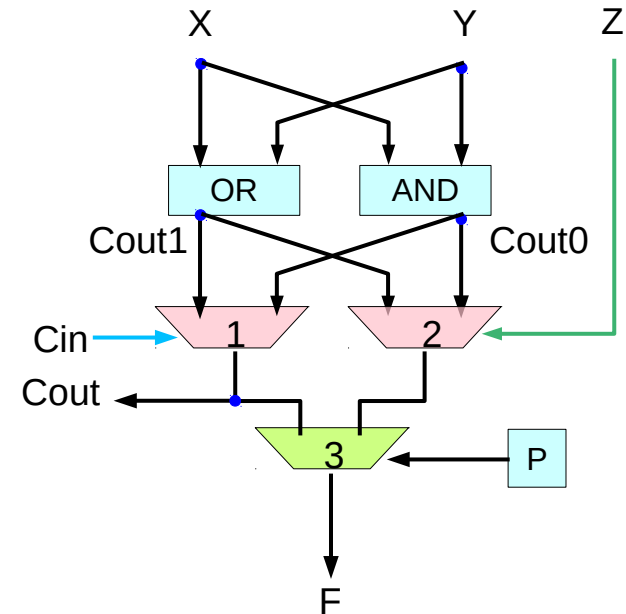
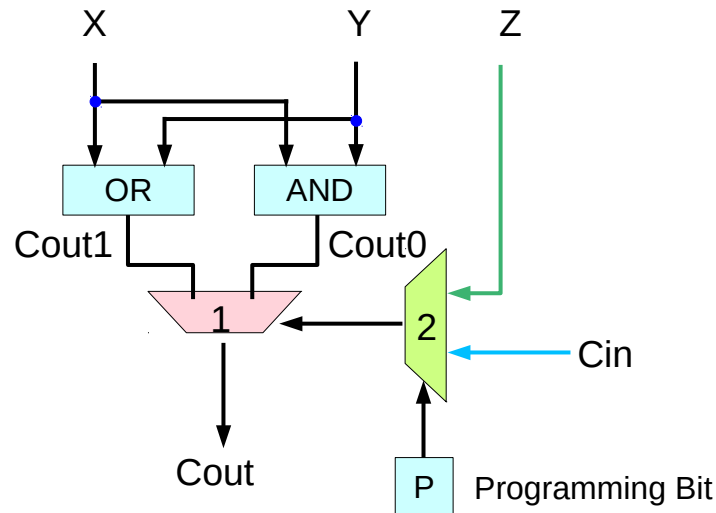

- not logically equivalent
- no longer use the **Z** input in the first cell since **Z** is only attached to **mux2** and **mux2** does not lead to the carry cells
- no longer use the **Cin** input in the first cell since **Cin** is only attached to **mux1** and **mux1** does not lead to the carry cells

High Performance Carry Chains for FPGAs, S. Hauck, M. M. Hosler, T. W. Fry

# Design A

delay of 2

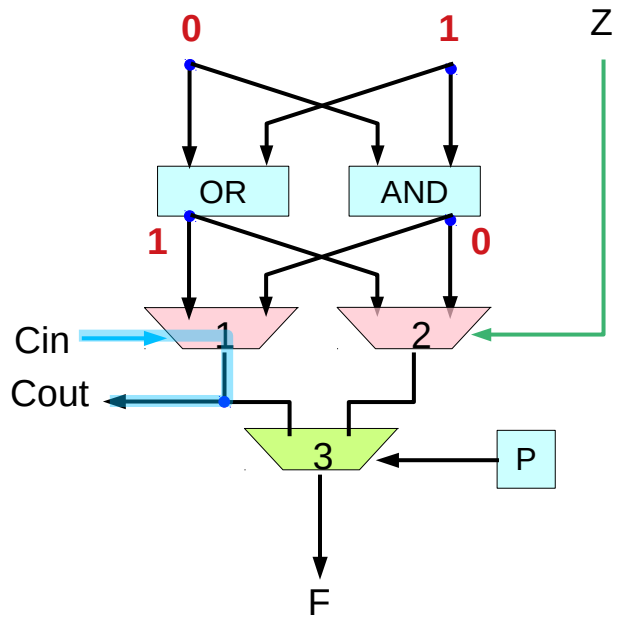

an additional cell  
for generating Cin

delay of 2

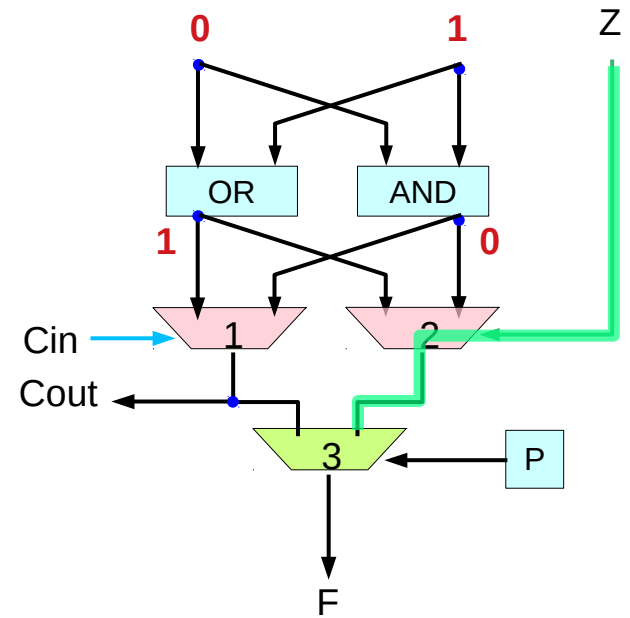

an additional cell  
for generating Cin



# Design A

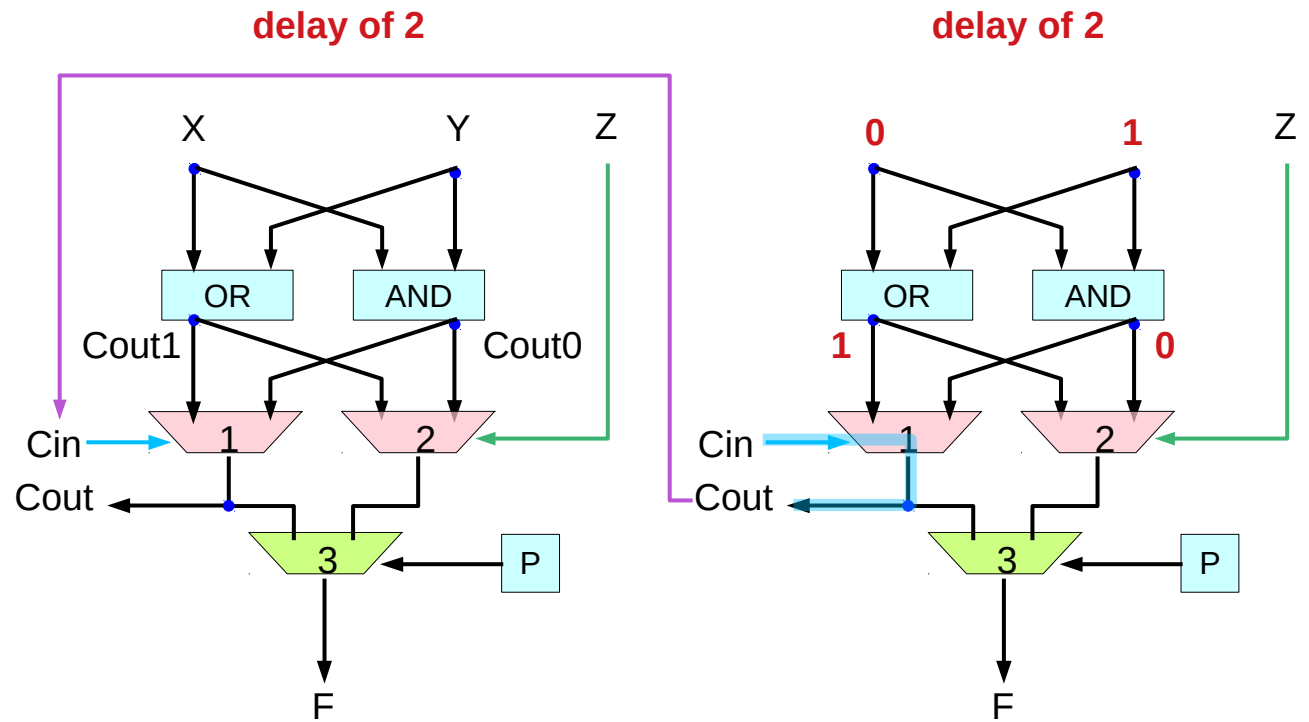

an additional cell  
for generating Cin

High Performance Carry Chains for FPGAs, S. Hauck, M. M. Hosler, T. W. Fry



# Design A

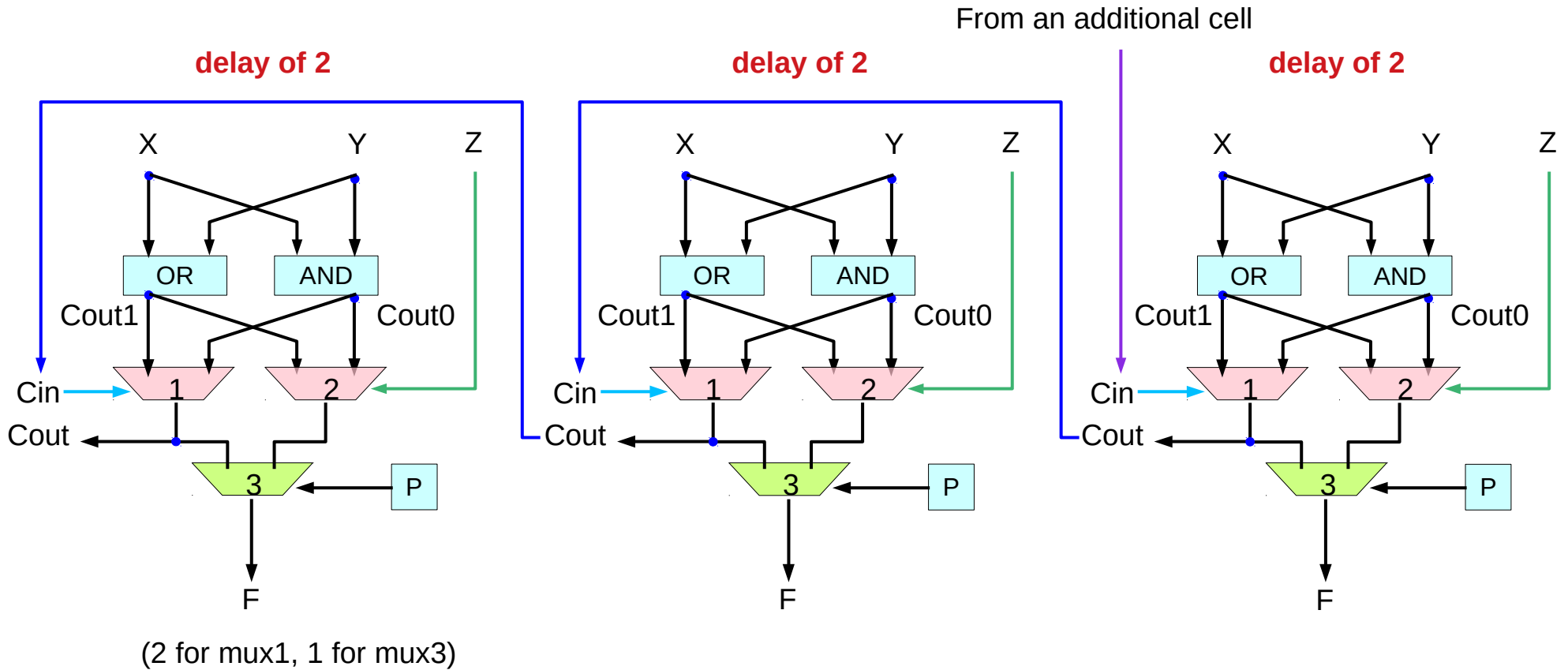

delay of  $2(n+1)$  for an  $n$ -bit ripple carry chain

High Performance Carry Chains for FPGAs, S. Hauck, M. M. Hosler, T. W. Fry

# Design B

thus, although this design is 1 gate delay slower than that of fig 2a, it provides the ability to have a carry input to the first cell in a carry chain, something that is important in many computations.

Also, for carry computations that do not need this feature, the first cell in a carry chain built from fig 2b can be configured to bypass mux1, reducing the overall delay to  $2n$ , which is identical to that of fig2a.

on the other hand, in order to implement a  $n$ -bit carry chain with a carry input, the design of fig 2a requires an additional cell at the beginning of the chain to bring in this input, resulting in a delay of  $2(n+1)=2n+2$ , which is lower than that of the design in fig2b thus, the design of fig 2b is the preferred ripple carry design among those presented so far

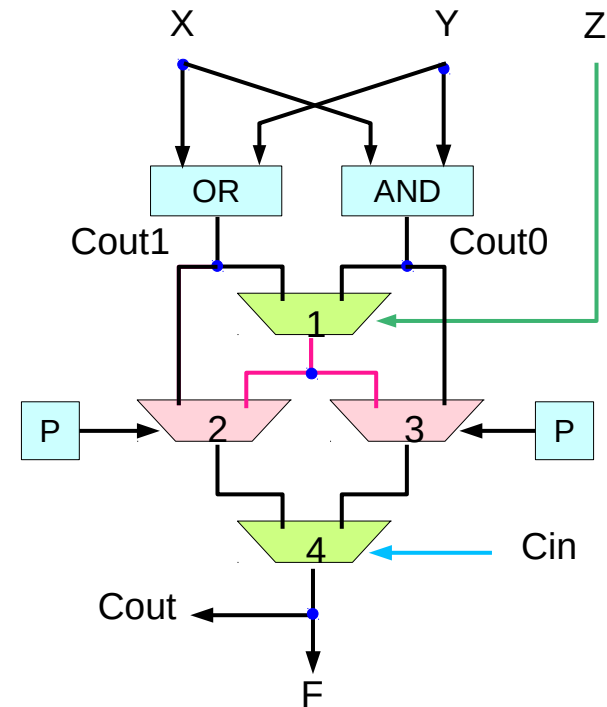

# Design B

although this design is 1 gate delay slower than that of fig 2a, it provides the ability to have a **carry input** to the **first cell** in a **carry chain**, something that is important in many computations.

Also, for carry computations that do not need this feature, without a **carry input** the first cell in a **carry chain** built from fig 2b can be configured to bypass mux1, reducing the overall delay to  $2n$ , which is identical to that of fig2a.

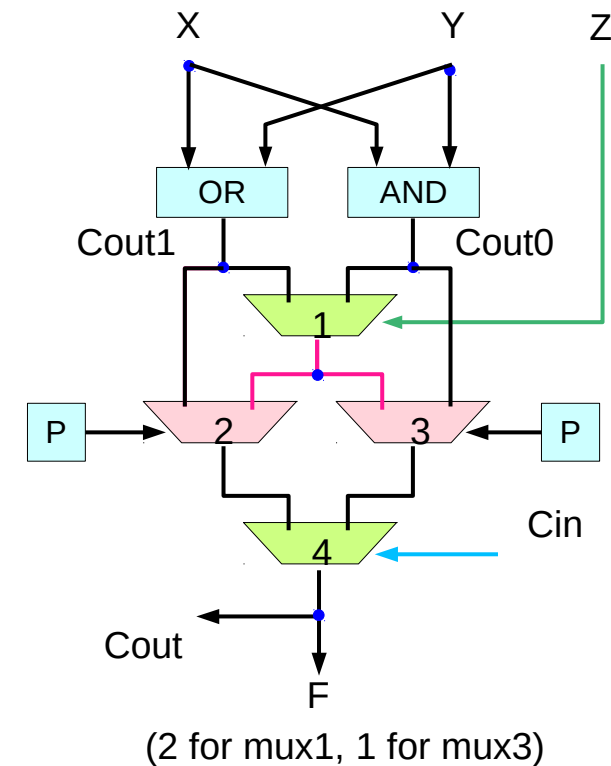

# Design B

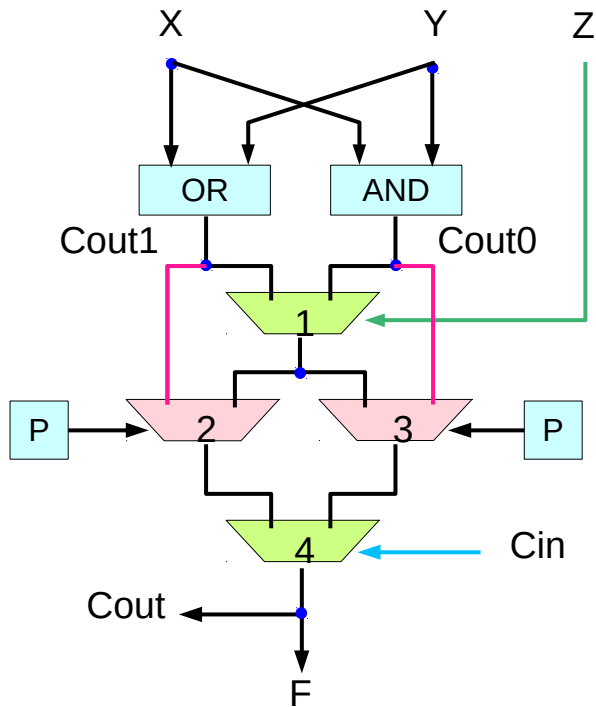

for cells in the middle of a carry chain  
mux2 passes Cout1  
mux3 passes Cout0  
mux4 receives Cout1 and Cout0  
provides a standard ripple carry path.

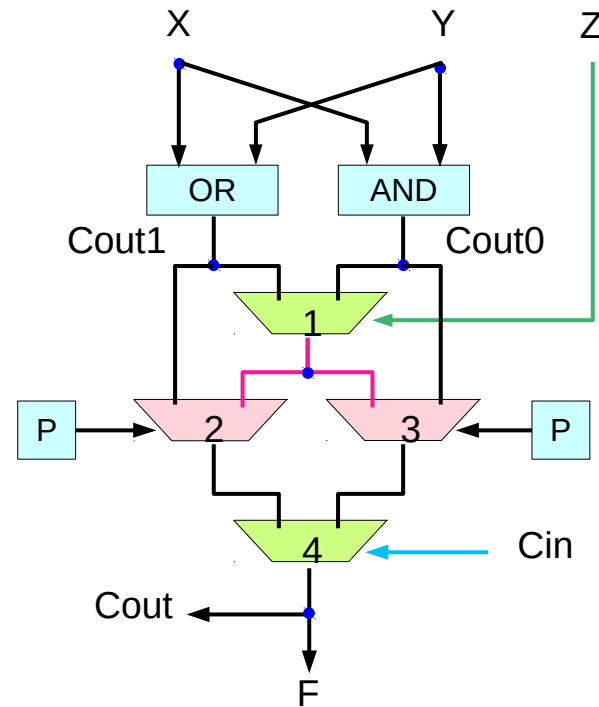

For the first cell in a carry chain  
with a carry input (provided by input Z),  
mux2 and mux3 both pass the value from mux1

the two main inputs to mux4 are identical  
the output of mux4 (Cout) will be the same  
as the output of mux1 (ignoring Cin)

High Performance Carry Chains for FPGAs, S. Hauck, M. M. Hosler, T. W. Fry

# Design B

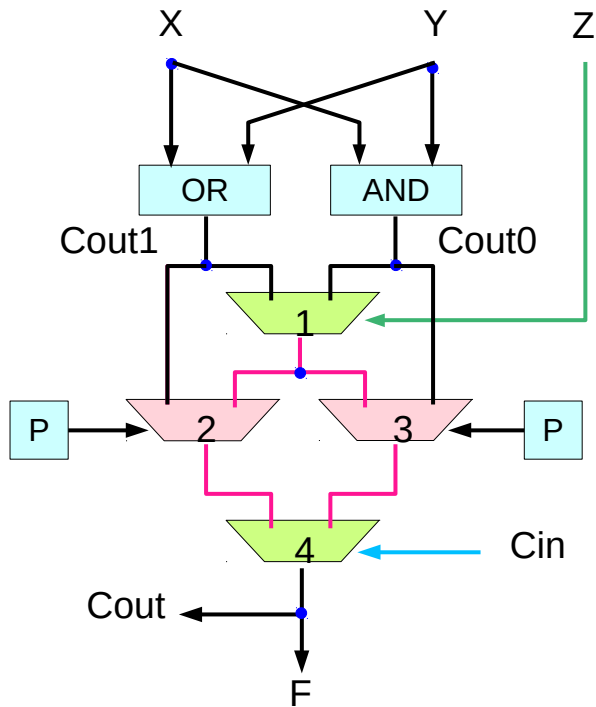

mux1's main inputs are driven by two 2-LUTs (OR, AND) controlled by X and Y  
mux1 forms a 3-LUT with the other 2-LUTs

When mux2 and mux3 pass the value from mux1 (Cout1 and Cout2 respectively) the circuit is configured to continue the carry chain

Functionally equivalent

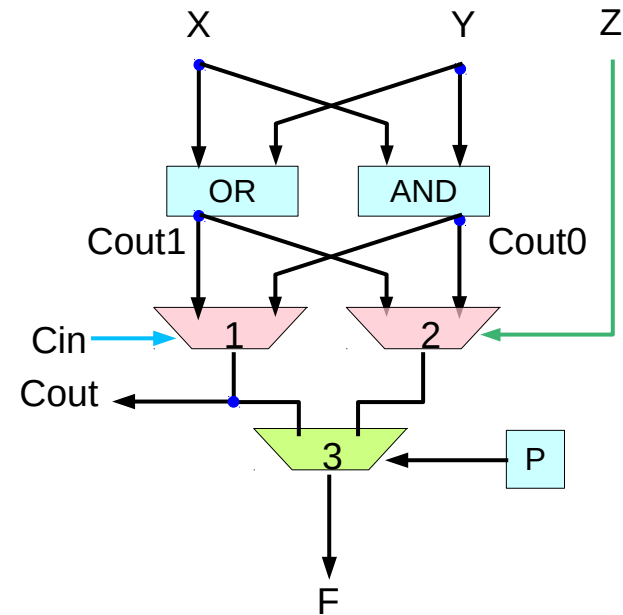

High Performance Carry Chains for FPGAs, S. Hauck, M. M. Hosler, T. W. Fry

# Design B

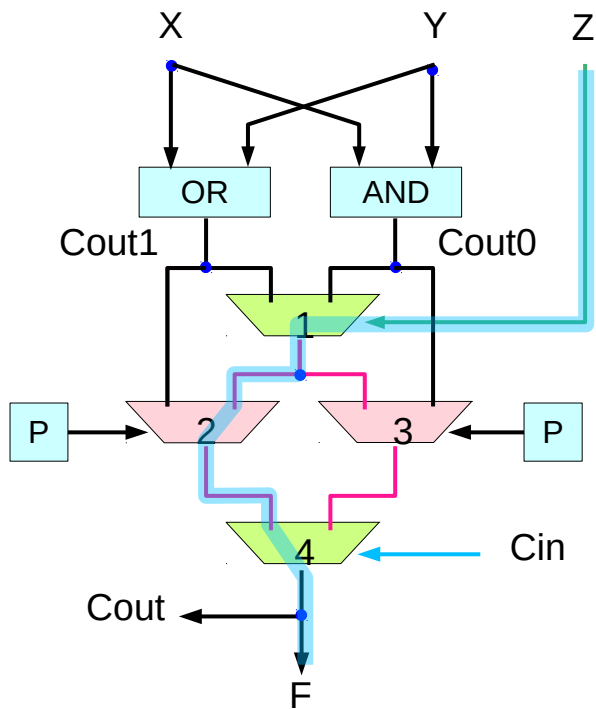

a delay of 3 in the first cell  
 (1 in mux1, 1 in mux2, 1 in mux4)  
 2 in all other cells in the carry chain  
 an total delay of  $2n+1$  for an  $n$ -bit carry chain

1 gate delay slower than that of fig 2a,  
 a carry input to the first cell is enabled

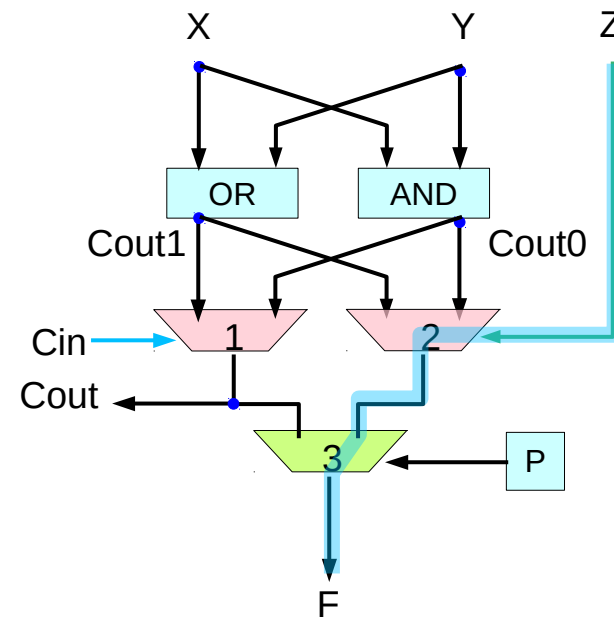

High Performance Carry Chains for FPGAs, S. Hauck, M. M. Hosler, T. W. Fry

# Design B

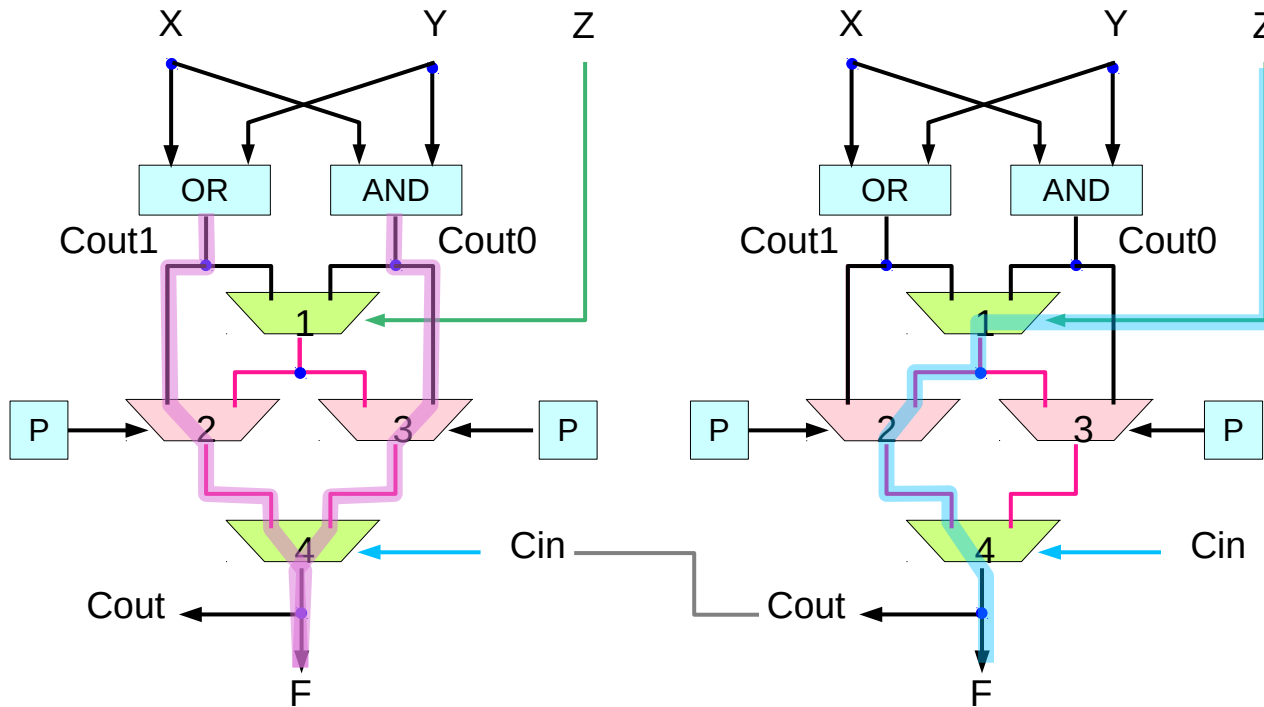

Also, for carry computations that do not need this feature, the first cell in a carry chain built from fig 2b can be configured to bypass mux1, reducing the overall delay to  $2n$ , which is identical to that of fig2a.

High Performance Carry Chains for FPGAs, S. Hauck, M. M. Hosler, T. W. Fry

# Design B

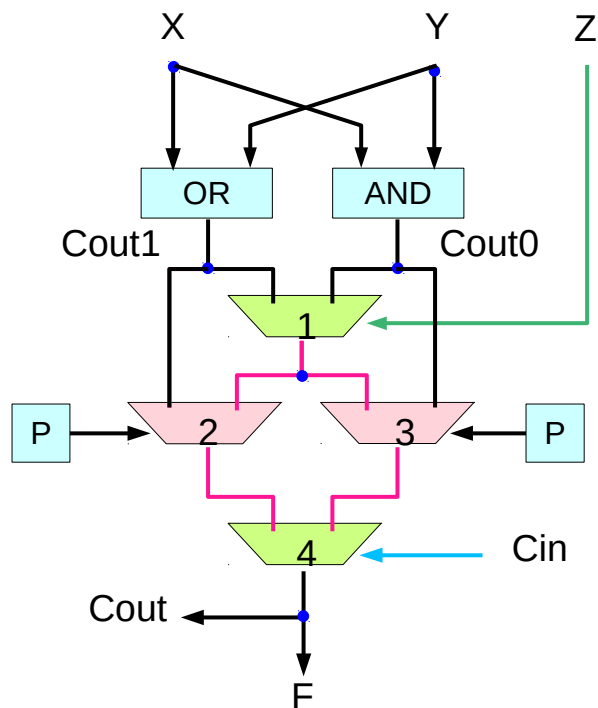

a delay of 3 in the first cell  
(1 in mux1, 1 in mux2, 1 in mux4)  
2 in all other cells in the carry chain  
an total delay of  $2n+1$  for an n-bit carry chain

$t_1$  gate delay slower than that of fig 2a,  
a carry input to the first cell is enabled

Also, for carry computations that do not need this feature,  
the first cell in a carry chain built from fig 2b  
can be configured to bypass mux1,  
reducing the overall delay to  $2n$ ,  
which is identical to that of fig2a.

in order to implement a n-bit carry chain **with a carry input**,  
the design of fig 2a requires an additional cell  
at the beginning of the chain to bring in this input,  
resulting in a delay of  $2(n+1)=2n+2$ ,  
which is lower than that of the design in fig2b

thus, the design of fig 2b is the preferred  
ripple carry design among those presented so far



# Design B

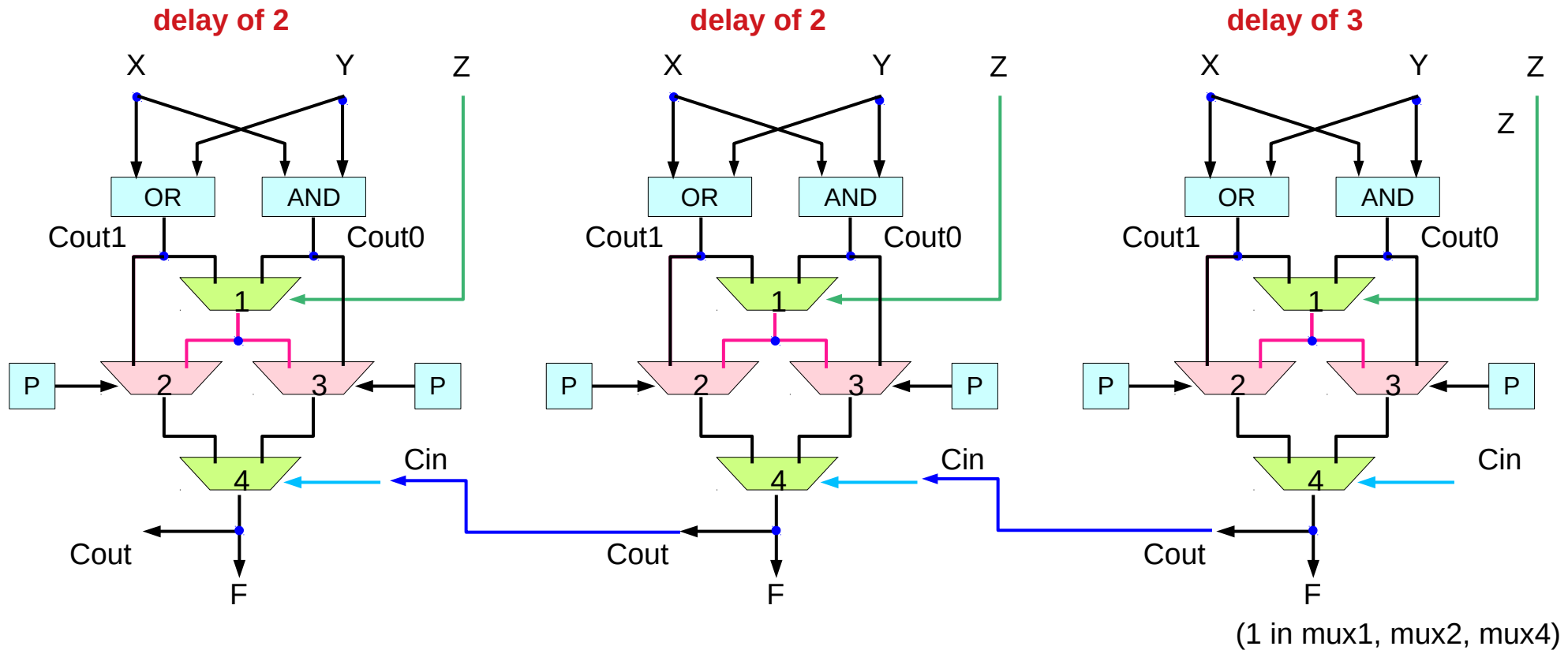

**delay of  $2n+1$**  for an  $n$ -bit ripple carry chain

50% faster circuit than the original design

High Performance Carry Chains for FPGAs, S. Hauck, M. M. Hosler, T. W. Fry

# Design C

various high performance carry chains can be developed based on the carry cell of fig 2c

this cell is very similar to that of fig 2b, except that the actual carry chain (mux4) has been replaced by an abstract fast carry logic unit and mux5 has been added

this extra mux5 is present because although some of our faster carry chains will have much faster carry propagation for long carry chains, they incur significant delay for non-carry computations

thus, when the cell is used as a simple normal 3LUT, using inputs X, Y, and Z mux5 allows us to bypass the carry chain by selecting the output of mux1

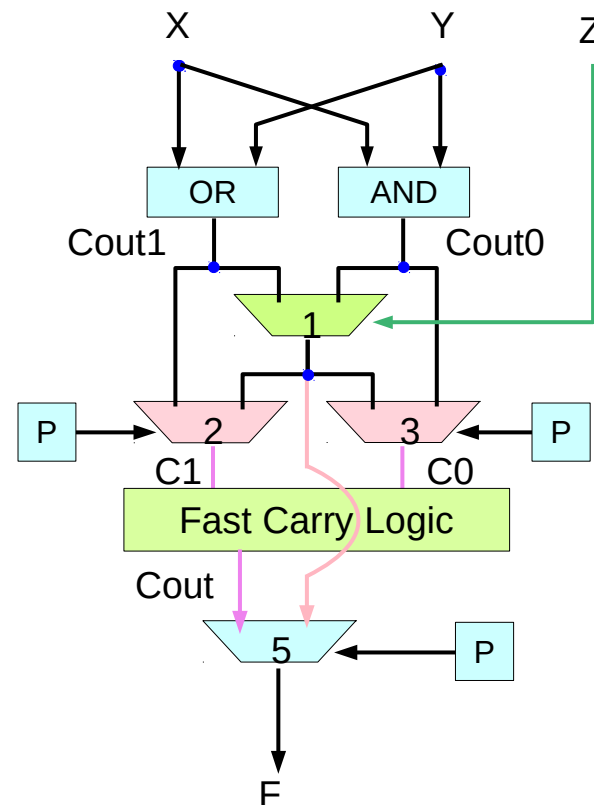

# Design C

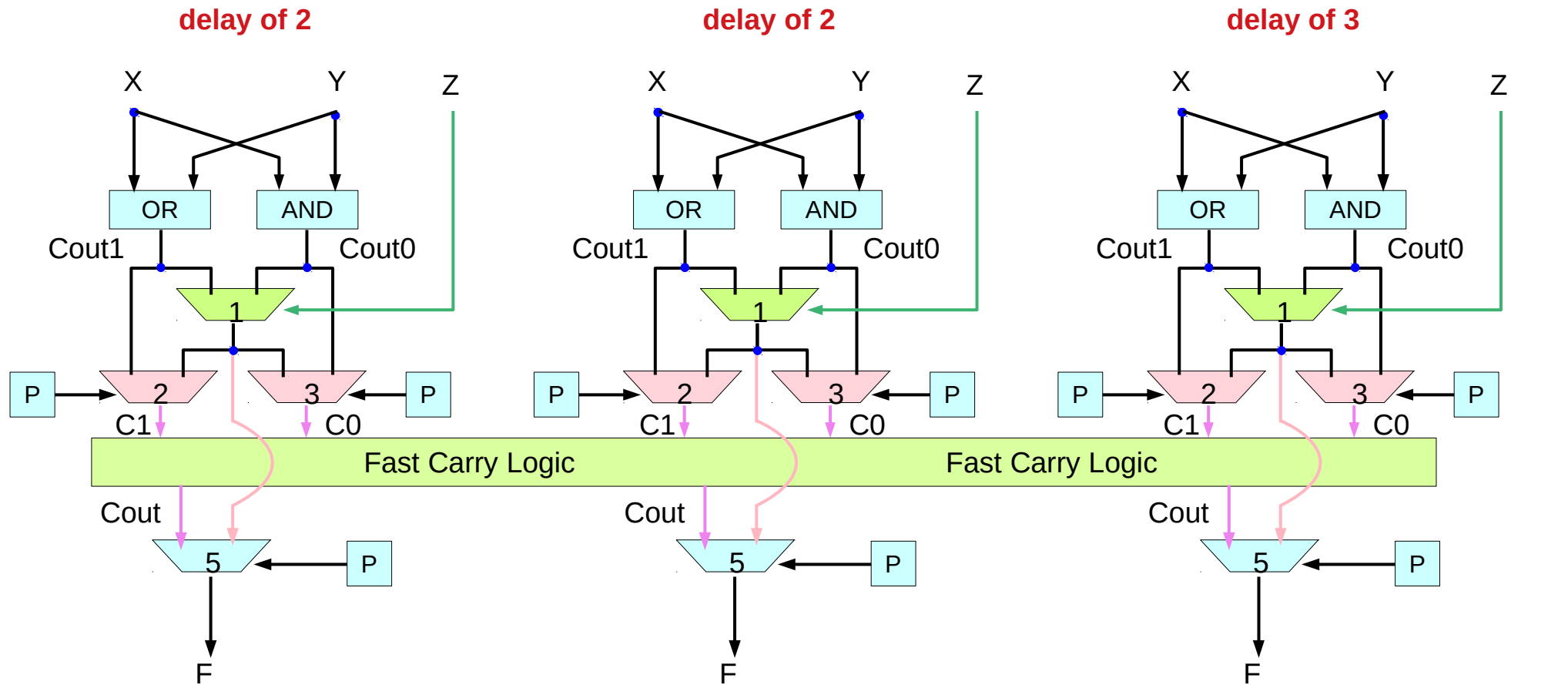

(1 for mux1, 1 for mux2, 1 in mux4)

delay of  $2n+2$  for an  $n$ -bit ripple carry chain

High Performance Carry Chains for FPGAs, S. Hauck, M. M. Hosler, T. W. Fry

# FPGA Carry Chain Cell

$2n$

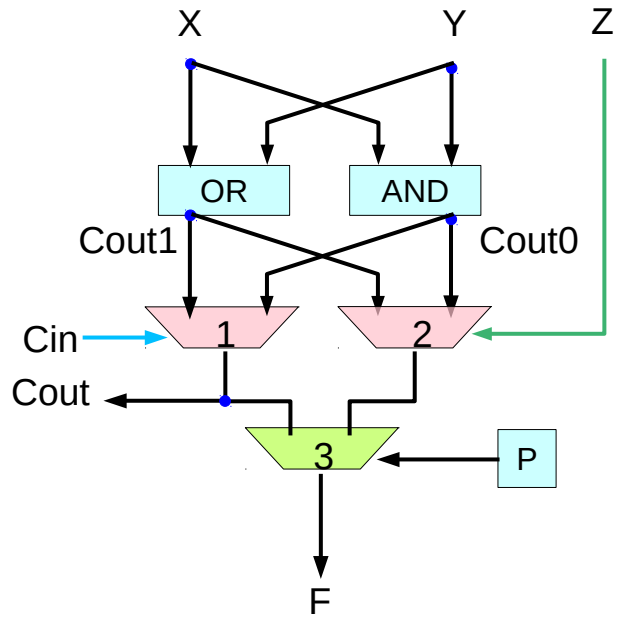

Design A

$2n / 2n+1$

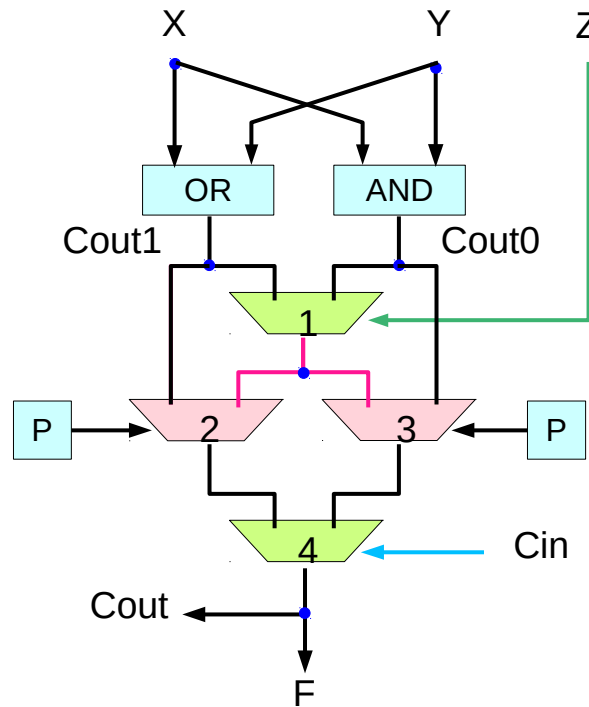

Design B

$2n+2$

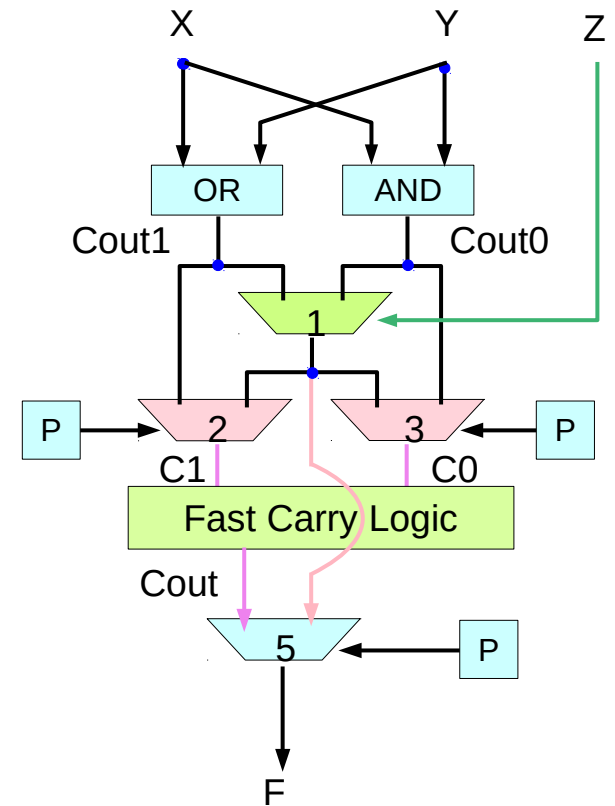

Design C

High Performance Carry Chains for FPGAs, S. Hauck, M. M. Hosler, T. W. Fry

# FPGA Carry Chain Cell

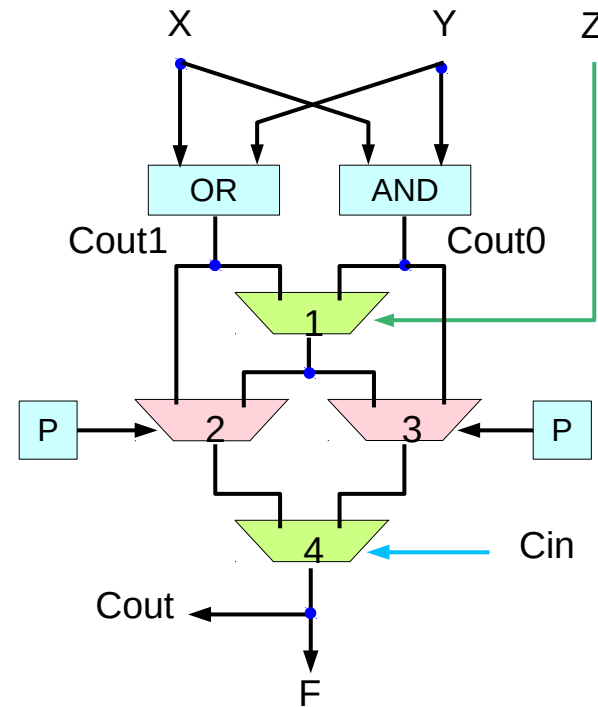
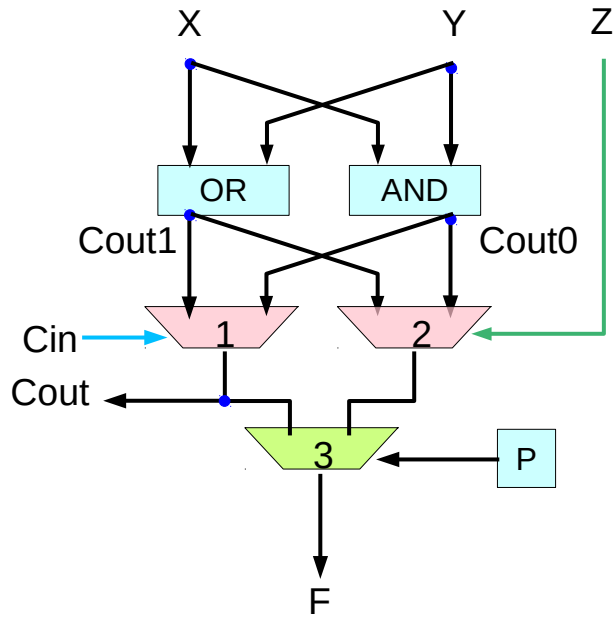

High Performance Carry Chains for FPGAs, S. Hauck, M. M. Hosler, T. W. Fry

# FPGA Carry Chain Cell

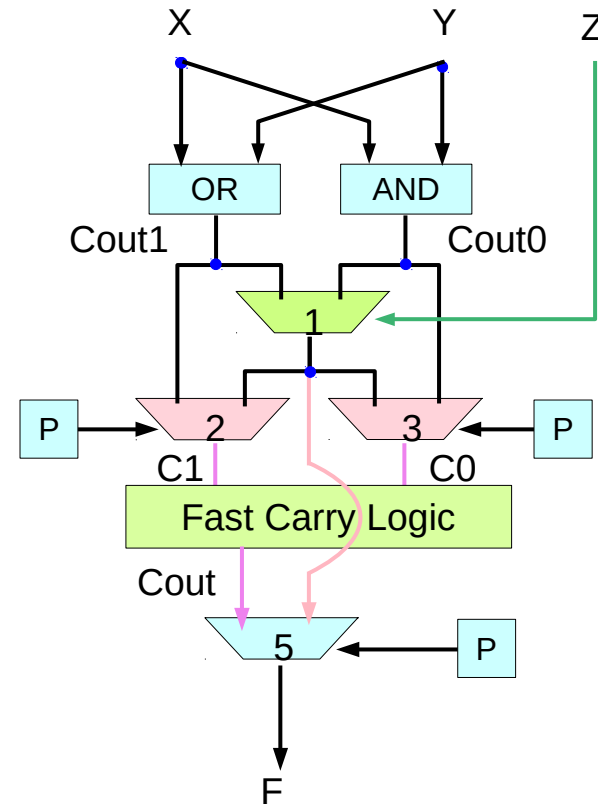
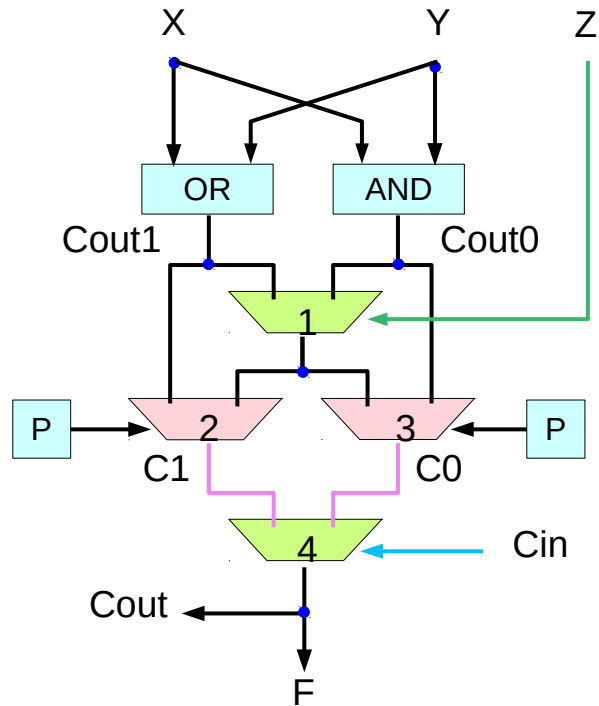

$$Cout_i = (Cout_{i-1} \cdot C1_i) + (\overline{Cout_{i-1}} \cdot C0_i)$$

High Performance Carry Chains for FPGAs, S. Hauck, M. M. Hosler, T. W. Fry

# FPGA Carry Chain Cell

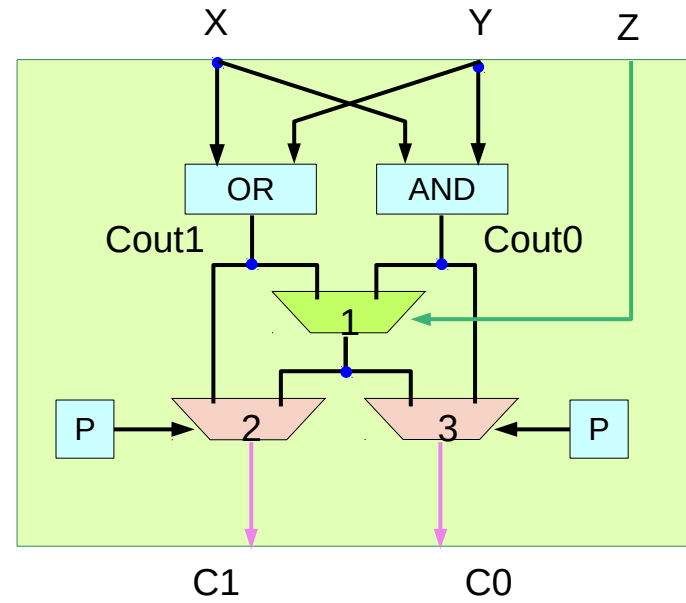

$$Cout_i = (Cout_{i-1} \cdot C1_i) + (\overline{Cout_{i-1}} \cdot C0_i)$$

High Performance Carry Chains for FPGAs, S. Hauck, M. M. Hosler, T. W. Fry

# Fast Carry Logc

---

Carry Select Adder  
Carry Lookahead Adder  
    Brent-Kung  
Variable Block  
Ripple Carry Adder

[https://en.wikipedia.org/wiki/Carry-lookahead\\_adder](https://en.wikipedia.org/wiki/Carry-lookahead_adder)



# FPGA Carry Chain Cell

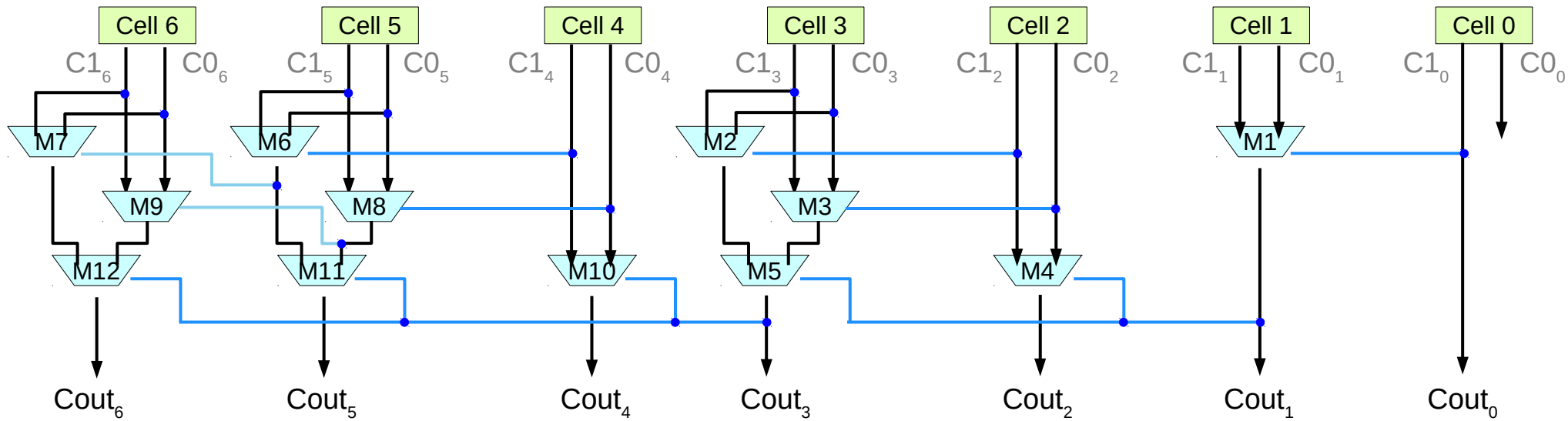

$$Cout_i = (Cout_{i-1} \cdot C1_i) + (\overline{Cout_{i-1}} \cdot C0_i)$$

High Performance Carry Chains for FPGAs, S. Hauck, M. M. Hosler, T. W. Fry

# FPGA Carry Chain Cell

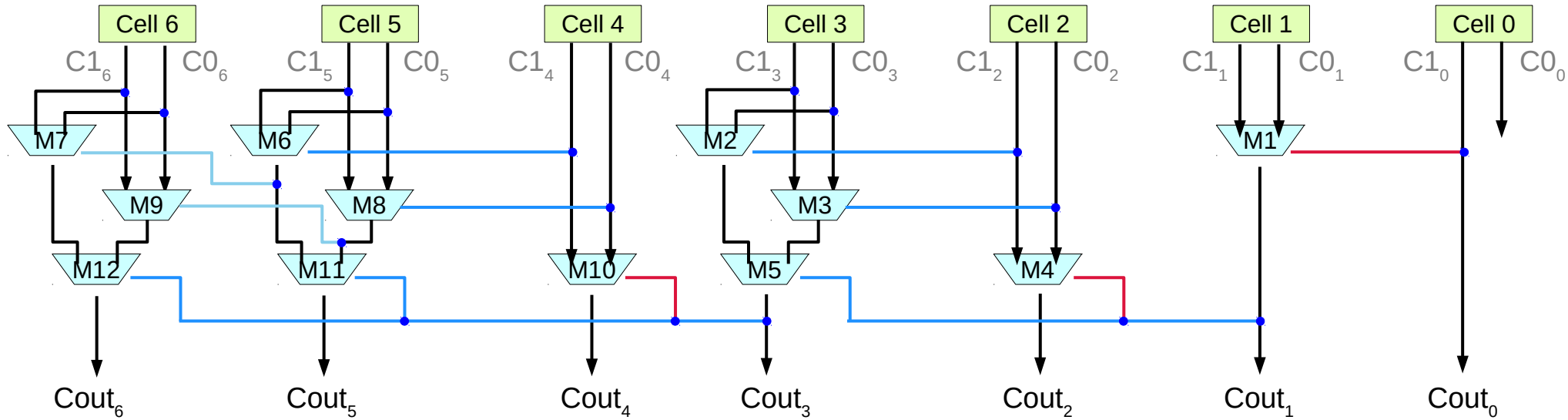

$$Cout_i = (Cout_{i-1} \cdot C1_i) + (\overline{Cout_{i-1}} \cdot C0_i)$$

$$Cout_1 = (Cout_0 \cdot C1_1) + (\overline{Cout_0} \cdot C0_1)$$

$$Cout_{i+1} = (Cout_i \cdot C1_{i+1}) + (\overline{Cout_i} \cdot C0_{i+1})$$

$$Cout_1 = (C1_0 \cdot C1_1) + (\overline{C1_0} \cdot C0_1)$$

$$Cout_{i+1} = (((Cout_{i-1} \cdot C1_i) + (\overline{Cout_{i-1}} \cdot C0_i)) \cdot C1_{i+1}) + (\overline{((Cout_{i-1} \cdot C1_i) + (\overline{Cout_{i-1}} \cdot C0_i))} \cdot C0_{i+1})$$

High Performance Carry Chains for FPGAs, S. Hauck, M. M. Hosler, T. W. Fry

# FPGA Carry Chain Cell

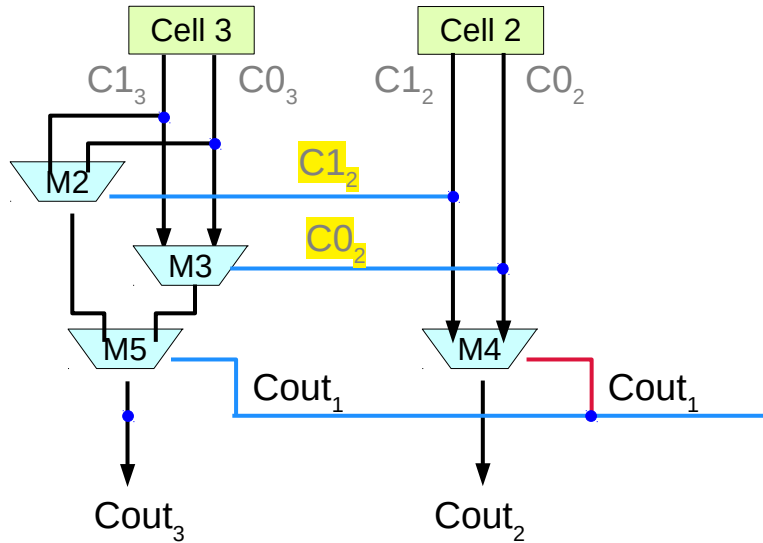

$$Cout_i = (Cout_{i-1} \cdot C1_i) + (\overline{Cout_{i-1}} \cdot C0_i)$$

$$Cout_{i+1} = (Cout_i \cdot C1_{i+1}) + (\overline{Cout_i} \cdot C0_{i+1})$$

$$Cout_2 = (Cout_1 \cdot C1_2) + (\overline{Cout_1} \cdot C0_2)$$

$$Cout_3 = (Cout_2 \cdot C1_3) + (\overline{Cout_2} \cdot C0_3)$$

$$= (((Cout_1 \cdot C1_2) + (\overline{Cout_1} \cdot C0_2)) \cdot C1_3)$$

$$+ (((Cout_1 \cdot C1_2) + (\overline{Cout_1} \cdot C0_2)) \cdot C0_3)$$

$$(((Cout_1 \cdot C1_2) + (\overline{Cout_1} \cdot C0_2)) \cdot C1_3)$$

$$= (C1_3 C1_2 Cout_1 + C1_3 C0_2 \overline{Cout_1})$$

$$(((\overline{Cout_1} \cdot C1_2) + (\overline{Cout_1} \cdot C0_2)) \cdot C0_3)$$

$$= (((\overline{Cout_1} + \overline{C1_2}) \cdot (\overline{Cout_1} + \overline{C0_2})) \cdot C0_3)$$

$$= (\overline{Cout_1} \overline{Cout_1} + \overline{C1_2} \overline{Cout_1} + \overline{Cout_1} \overline{C0_2} + \overline{C1_2} \overline{C0_2}) \cdot C0_3$$

$$= (\overline{C1_2} \overline{Cout_1} + \overline{C0_2} \overline{Cout_1}) \cdot C0_3$$

$$= (C0_3 \overline{C1_2} \overline{Cout_1} + C0_3 \overline{C0_2} \overline{Cout_1})$$

$$(C1_3 C1_2 + C0_3 \overline{C1_2}) Cout_1 + (C1_3 C0_2 + C0_3 \overline{C0_2}) \overline{Cout_1}$$

High Performance Carry Chains for FPGAs, S. Hauck, M. M. Hosler, T. W. Fry

# FPGA Carry Chain Cell

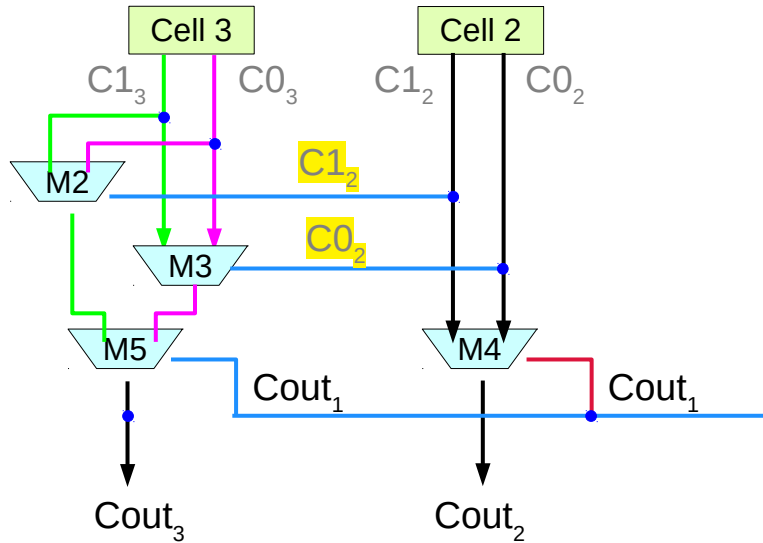

$$\begin{aligned}
 &= (\overline{Cout_1}Cout_1 + \overline{C1_2}Cout_1 + \overline{Cout_1}C0_2 + \overline{C1_2}C0_2) \cdot C0_3 \\
 &= (\overline{C1_2}Cout_1 + \overline{C0_2}Cout_1) \cdot C0_3 \\
 &= (C0_3\overline{C1_2}Cout_1 + C0_3\overline{C0_2}Cout_1)
 \end{aligned}$$

$$(C1_3 C1_2 + C0_3 \overline{C1_2})Cout_1 + (C1_3 C0_2 + C0_3 \overline{C0_2})\overline{Cout_1}$$

High Performance Carry Chains for FPGAs, S. Hauck, M. M. Hosler, T. W. Fry

# FPGA Carry Chain Cell

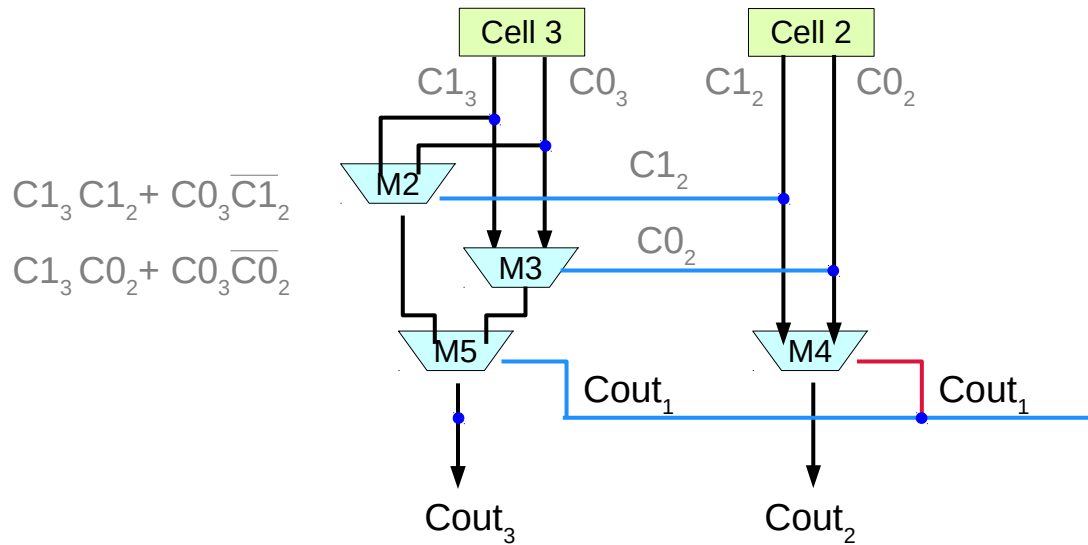

$$C1_3 C1_2 + C0_3 \overline{C1_2}$$

$$C1_3 C0_2 + C0_3 \overline{C0_2}$$

$$(C1_3 C1_2 + C0_3 \overline{C1_2})Cout_1 + (C1_3 C0_2 + C0_3 \overline{C0_2})\overline{Cout_1}$$

$$= C1_3 \cdot (C1_2 Cout_1 + C0_2 \overline{Cout_1})$$

$$+ C0_3 \cdot (\overline{C1_2} Cout_1 + \overline{C0_2} \overline{Cout_1})$$

High Performance Carry Chains for FPGAs, S. Hauck, M. M. Hosler, T. W. Fry

# FPGA Carry Chain Cell

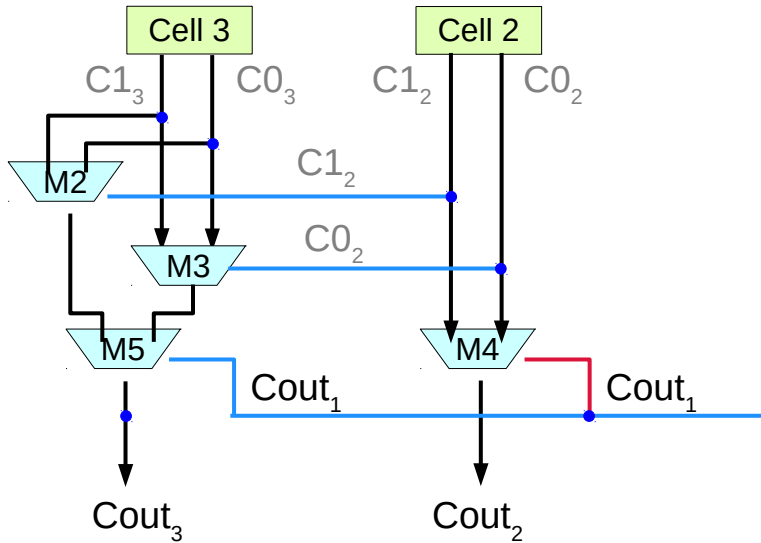

$$Cout_i = (Cout_{i-1} \cdot C1_i) + (\overline{Cout_{i-1}} \cdot C0_i)$$

$$Cout_{i+1} = (Cout_i \cdot C1_{i+1}) + (\overline{Cout_i} \cdot C0_{i+1})$$

$$Cout_{i+1} = [(Cout_{i-1} \cdot C1_i) + (\overline{Cout_{i-1}} \cdot C0_i)] \cdot C1_{i+1} + \overline{[(Cout_{i-1} \cdot C1_i) + (\overline{Cout_{i-1}} \cdot C0_i)]} \cdot C0_{i+1}$$

High Performance Carry Chains for FPGAs, S. Hauck, M. M. Hosler, T. W. Fry

---

## References

[1] <http://en.wikipedia.org/>

[2] J-P Deschamps, et. al., “Sunthesis of Arithmetic Circuits”, 2006