

Array Pointers (1A)

Copyright (c) 2022 - 2010 Young W. Lim.

Permission is granted to copy, distribute and/or modify this document under the terms of the GNU Free Documentation License, Version 1.2 or any later version published by the Free Software Foundation; with no Invariant Sections, no Front-Cover Texts, and no Back-Cover Texts. A copy of the license is included in the section entitled "GNU Free Documentation License".

Please send corrections (or suggestions) to youngwlim@hotmail.com.
This document was produced by using LibreOffice.

Assumption

assume that

value(c) returns the hexadecimal number that is obtained by `printf("%p", c)`, when the variable `c` contains an address as its value

type(c) can be determined by the warning message of `printf("%d", c)`, when the variable `c` contains an address as its value

```
#include <stdio.h>
int main(void) {
    int c[3];
    printf ("c= %p \n", &c);
}
```

`c= 0x7fffd923487c`

```
#include <stdio.h>
int main(void) {
    int c[3];
    printf ("c= %d \n", &c);
}
```

t.c: In function 'main':
t.c:5:16: warning: format '%d' expects argument of type 'int',
but argument 2 has type 'int (*)[3]' [-Wformat=]
printf ("c= %d \n", &c);

Array Pointers

Pointer to Arrays

1. pointer to 1-d arrays

```
int (*p) [4];
```

2. pointer to 2-d arrays

```
int (*q) [4][4];
```

Pointer to an array – variable declarations

```
int m ;
```

```
int *n ;
```

an integer pointer

Array **Pointer Approach**
(**pointer to arrays**)

```
int a [4]
```

```
int (*p) [4]
```

an array pointer

```
int func (int a, int b) ;
```

```
int (*fp) (int a, int b) ;
```

a function pointer

Pointer to an array – variable declarations

n points to a number (`int`)

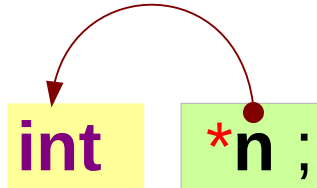

an integer pointer

Array **Pointer Approach**
(**pointer to arrays**)

p points to an array (`int [4]`)

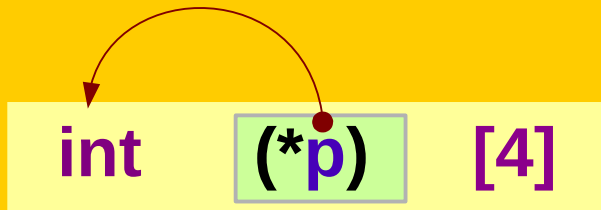

an array pointer

fp points to a function (`int (int, int)`)

```
int (*fp) (int a, int b);
```

a function pointer

Pointer to an array – a type view

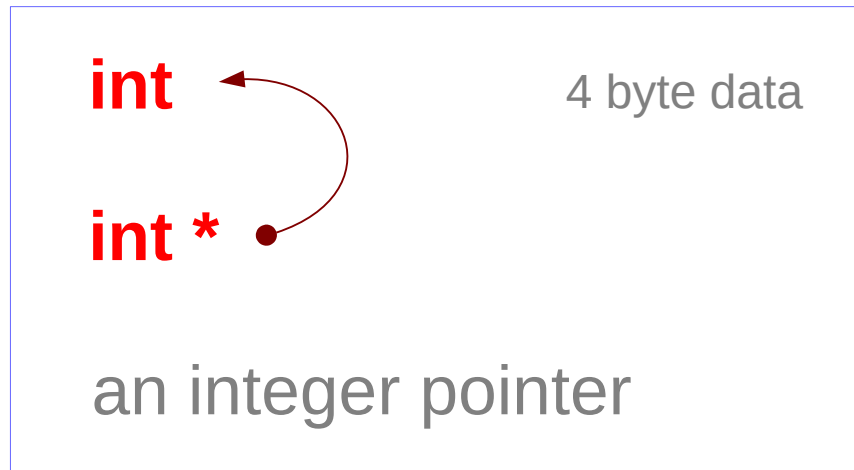

array pointer:
a pointer to an array

pointer array:
an array of pointers

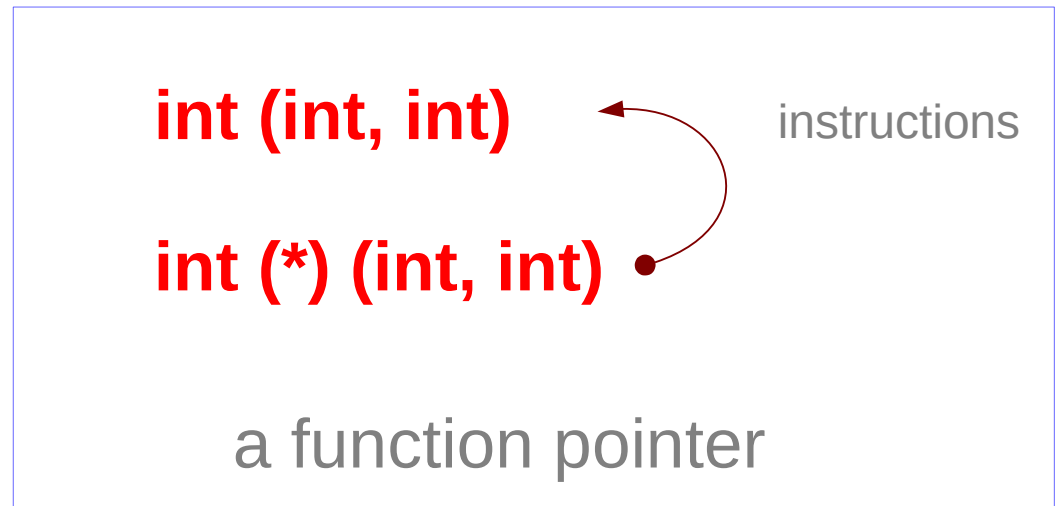
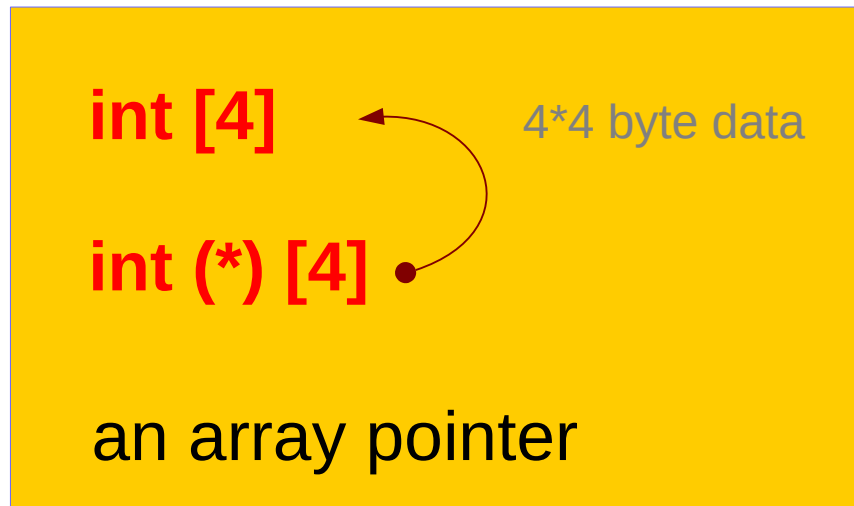

Pointer **q** to a **1-d** array **a**

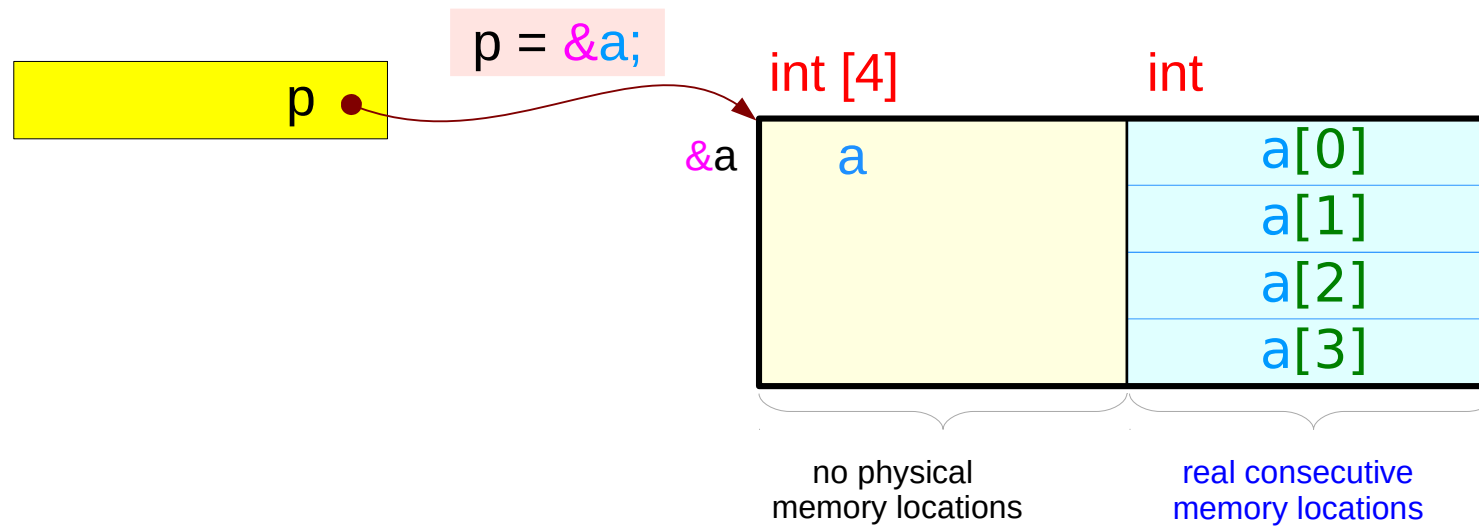

1-d array pointer

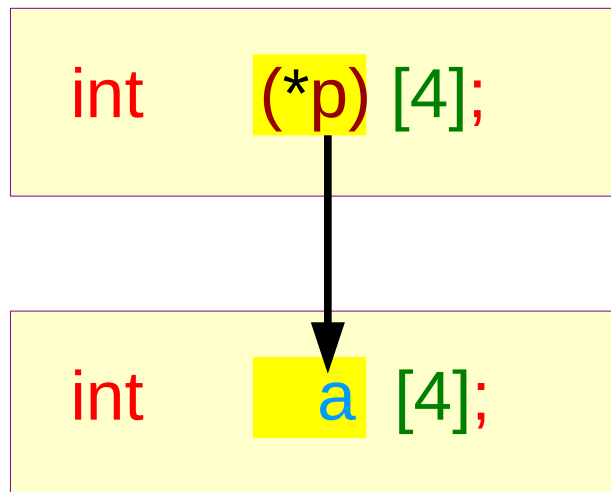

Pointer **q** to a **2-d** array **c**

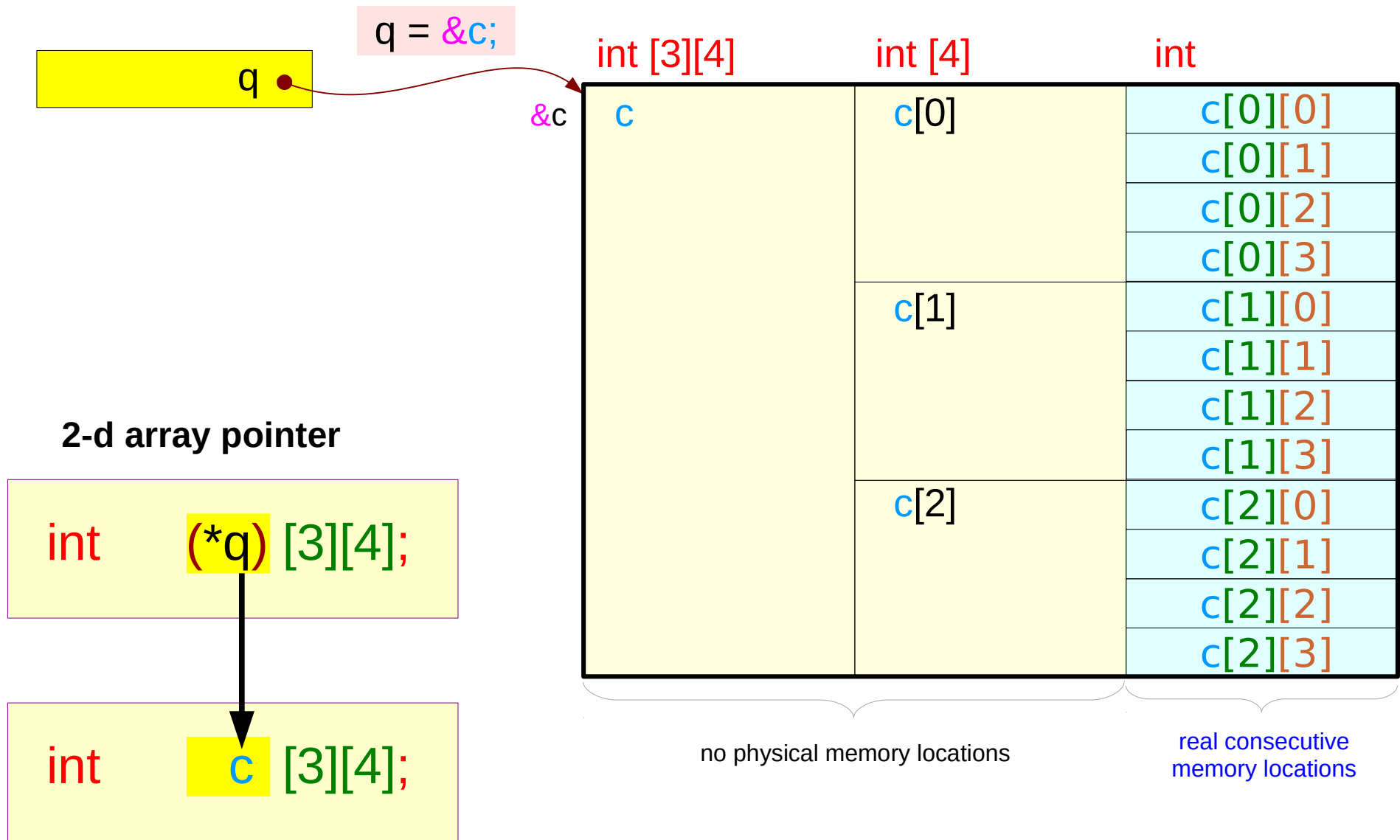

Array **a** vs array pointer **A**

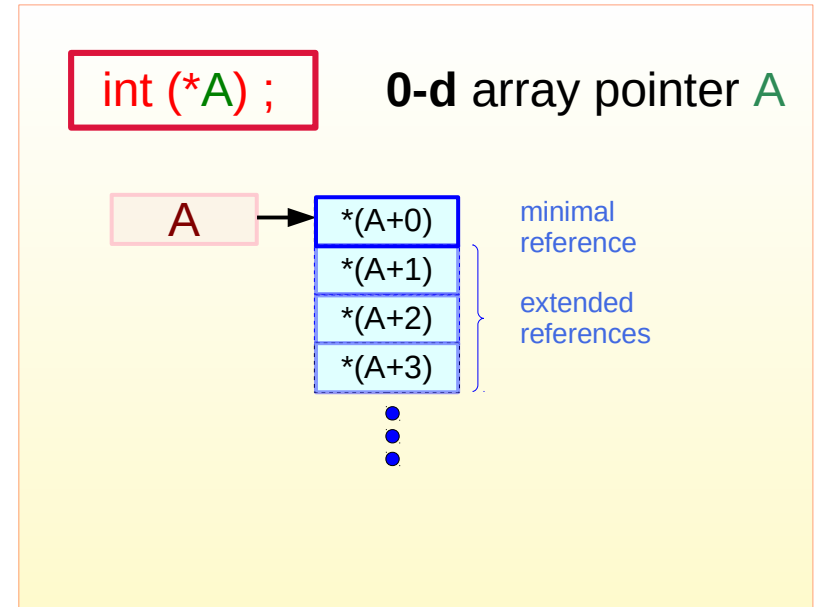
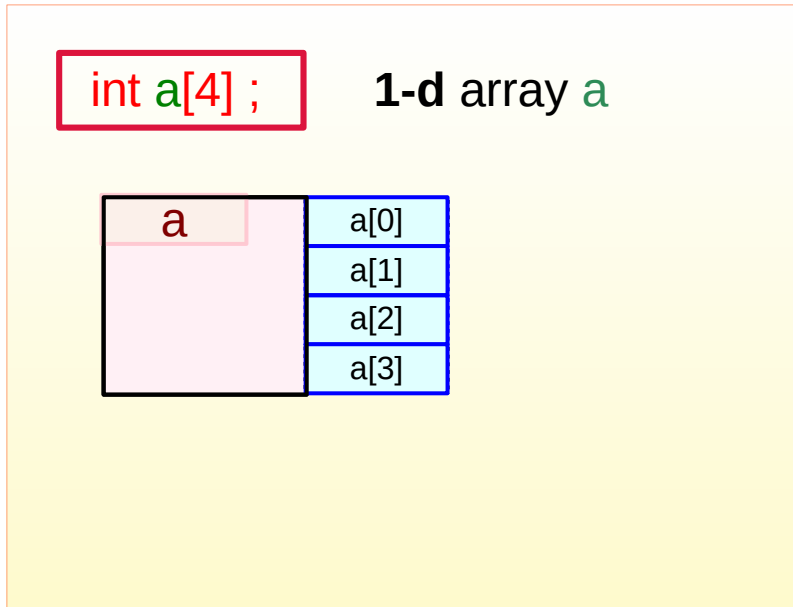

`int (*)` **a** as a 0-d array pointer

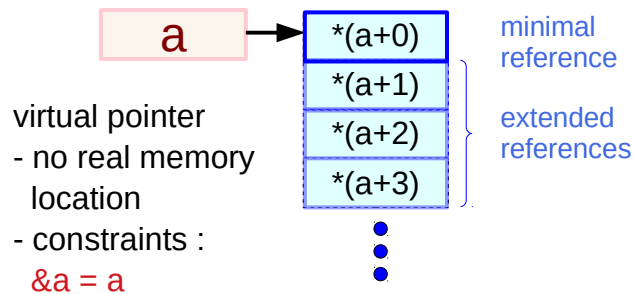

`int [N]` **A** as a 1-d array

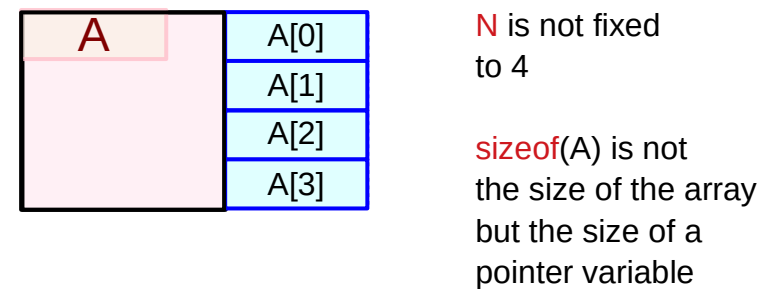

Array **a** and array pointers **A**

`int a[4];` **1-d** array **a**

- `sizeof(a)` = an array size
= 4 * 4 bytes
- # of 0-d arrays = fixed
= 4

`int (*A);` **0-d** array pointer **A**

- `sizeof(A)` = a pointer size
= 4 / 8 bytes
- # of 0-d arrays = not fixed
= at least 1

`int (*)` **a** as a **0-d** array pointer

a is not a real pointer

- `sizeof(a)` = an array size
- `a = &a`

`int [N]` **A** as a **1-d** array

A is not a real array

- `sizeof(A)` = a pointer size
- `A ≠ &A`

Array and pointer types in a 1-d array

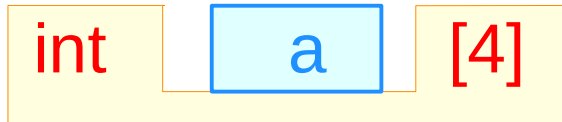

a 1-d array

type : **int** [4]

size : 4 * 4



a 0-d array pointer (virtual)

type : **int** (*)

size : 4 * 4

a points to the 1st **int** element
there are 4 **int** elements

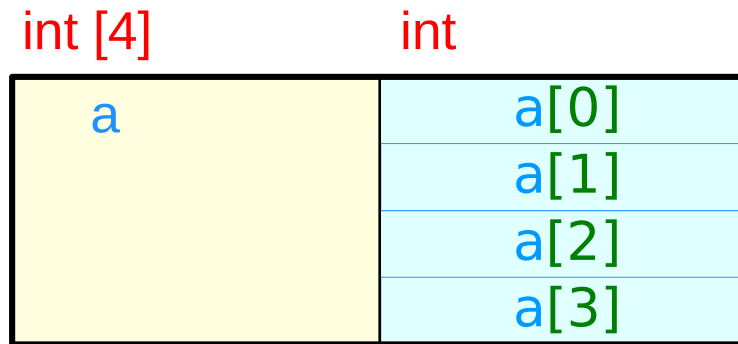

no physical
memory locations

real consecutive
memory locations

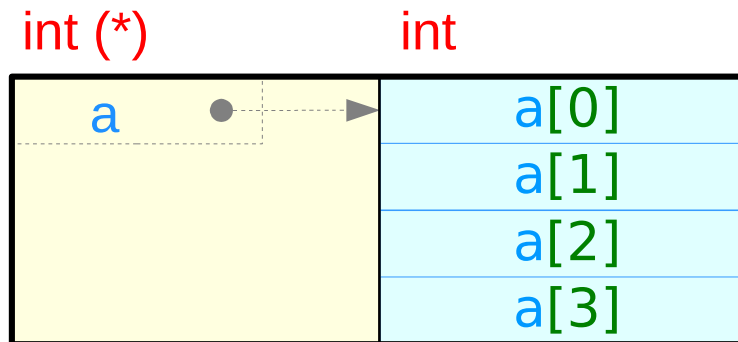

no physical
memory locations

real consecutive
memory locations

2-d array type

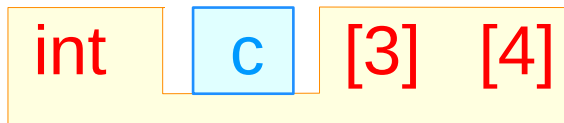

C 2-d array

type : int [3][4]

size : 3 * 4 * 4

int [3][4]

c	c[0]	c[0][0]
		c[0][1]
		c[0][2]
		c[0][3]
	c[1]	c[1][0]
		c[1][1]
		c[1][2]
		c[1][3]
	c[2]	c[2][0]
		c[2][1]
		c[2][2]
		c[2][3]

no physical memory locations

real consecutive
memory locations

1-d array pointer type

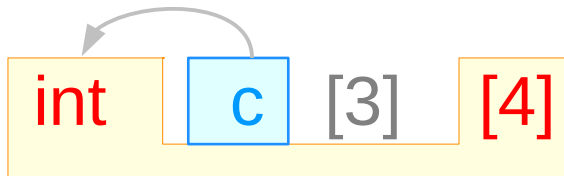

C 1-d array pointer (virtual)

type : `int (*) [4]`

size : `3 * 4 * 4`

`c` points to the 1st `int [4]` element
There are 3 `int [4]` elements

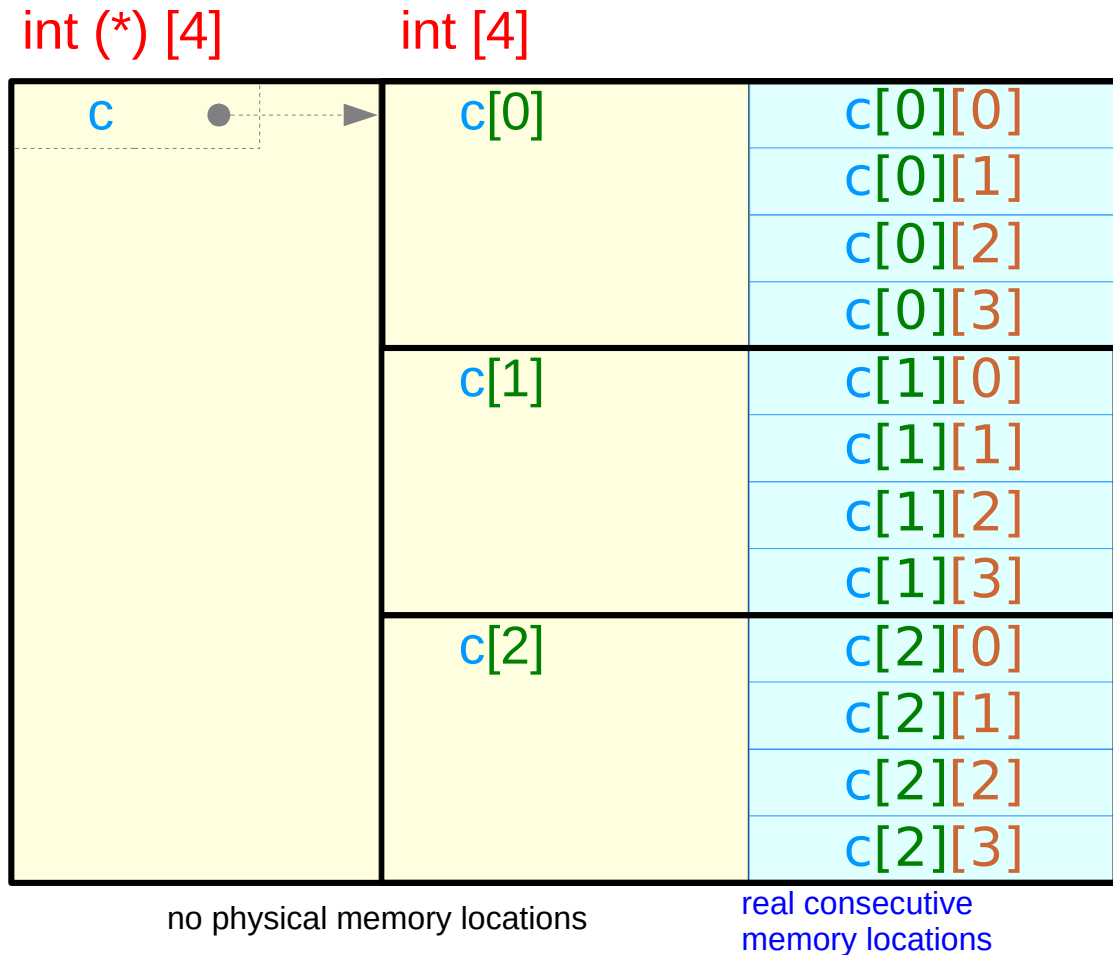

1-d array type

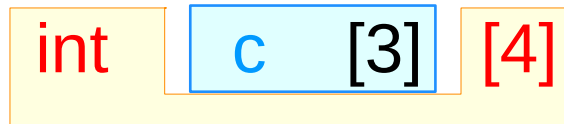

c[i] 1-d array

type : int [4]

size : 4 * 4

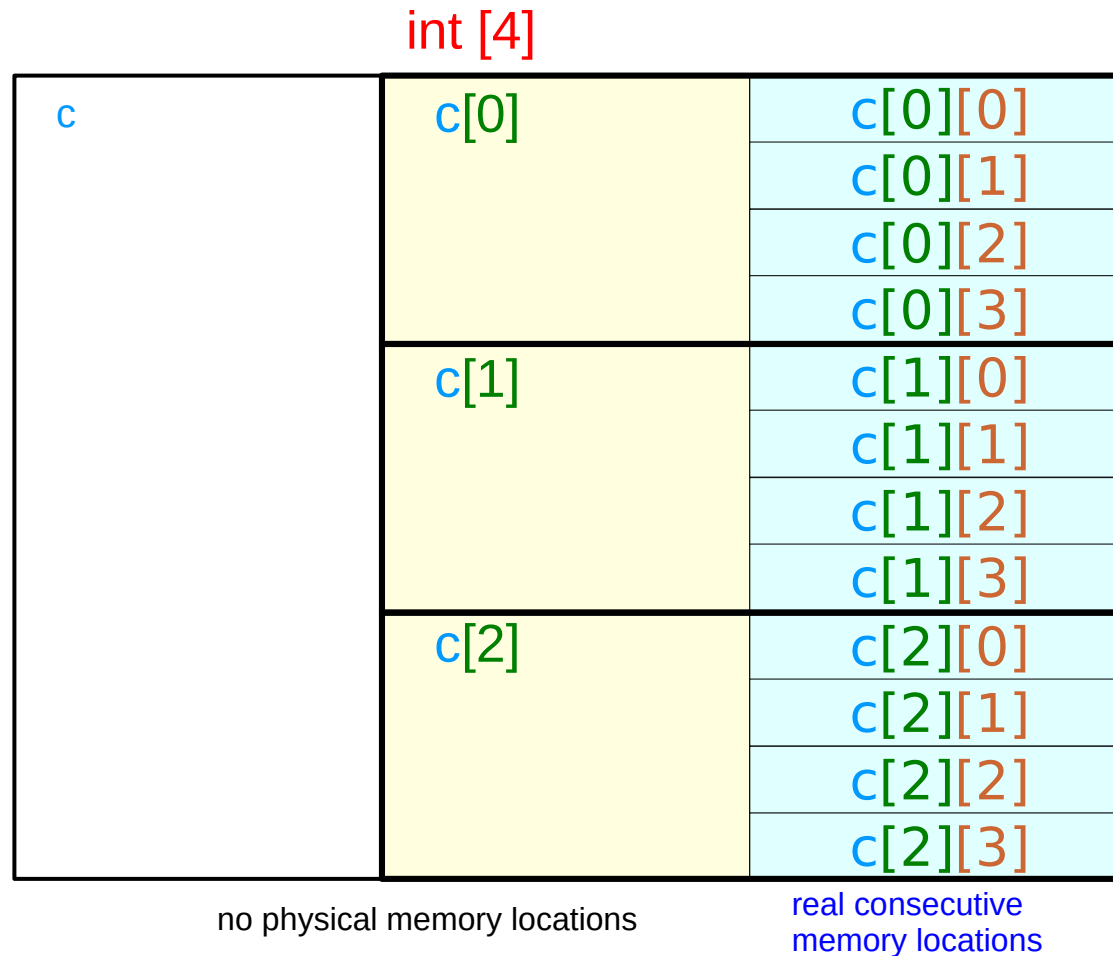

0-d array pointer type

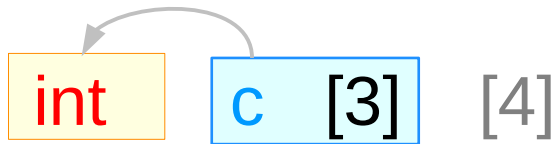

c[i] 0-d array pointer (virtual)

type : int (*)

size : 4 * 4

c[i] points to the 1st int element
There are 4 int elements

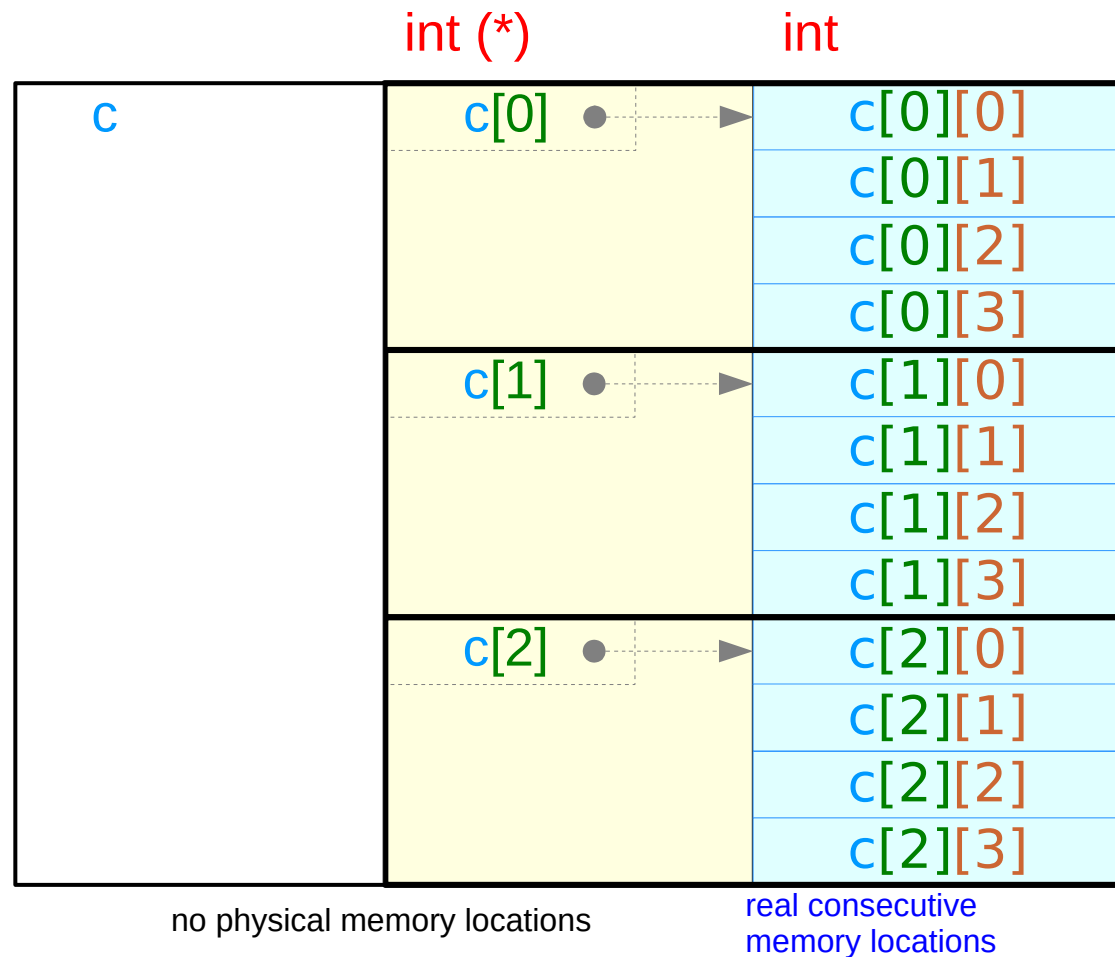

Values of virtual array pointer in a 2-d array

$c = c[0] = \&c[0][0]$

$c[1] = \&c[1][0]$

$c[2] = \&c[2][0]$

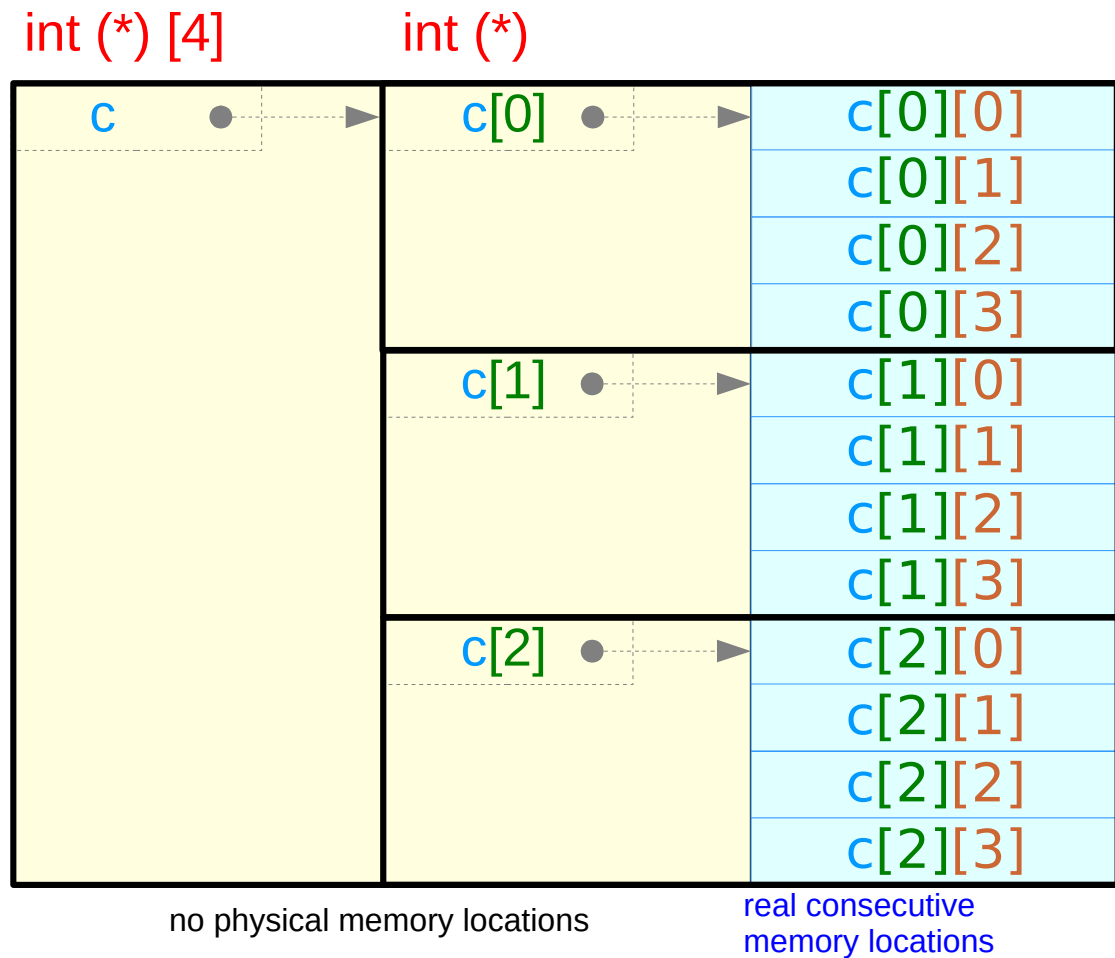

Types in a 2-d array

int c [3] [4]

C 2-d array

type : int [3][4]

size : 3 * 4 * 4

value : &c[0][0]

relaxing the 1st dimension



int c [3] [4]

C 1-d array pointer (virtual)

type : int (*) [4]

size : 3 * 4 * 4

value : &c[0][0]

int c [3] [4]

C[i] 1-d array

type : int [4]

size : 4 * 4

value : &c[i][0]

relaxing the 1st dimension



int c [3] [4]

C[i] 0-d array pointer (virtual)

type : int (*)

size : 4 * 4

value : &c[i][0]

Subarray types in a 2-d array

`int c[3][4];` 2-d array `c`

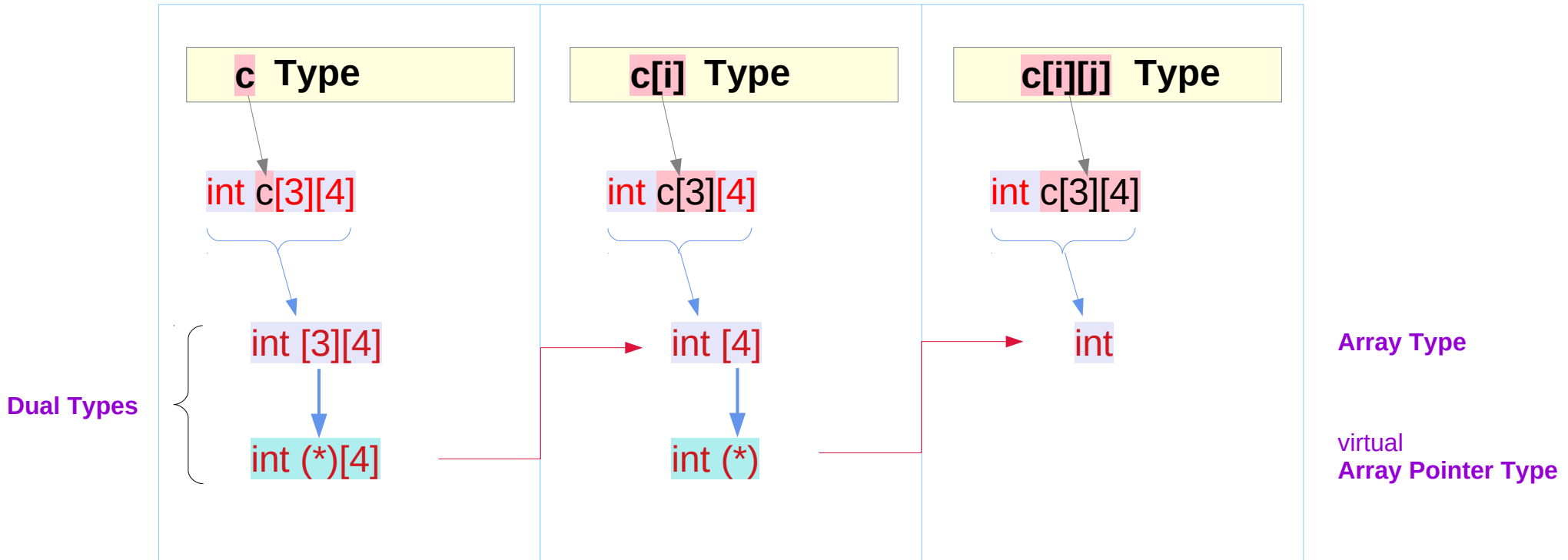

Pointer **p** to a 1-d array **a**

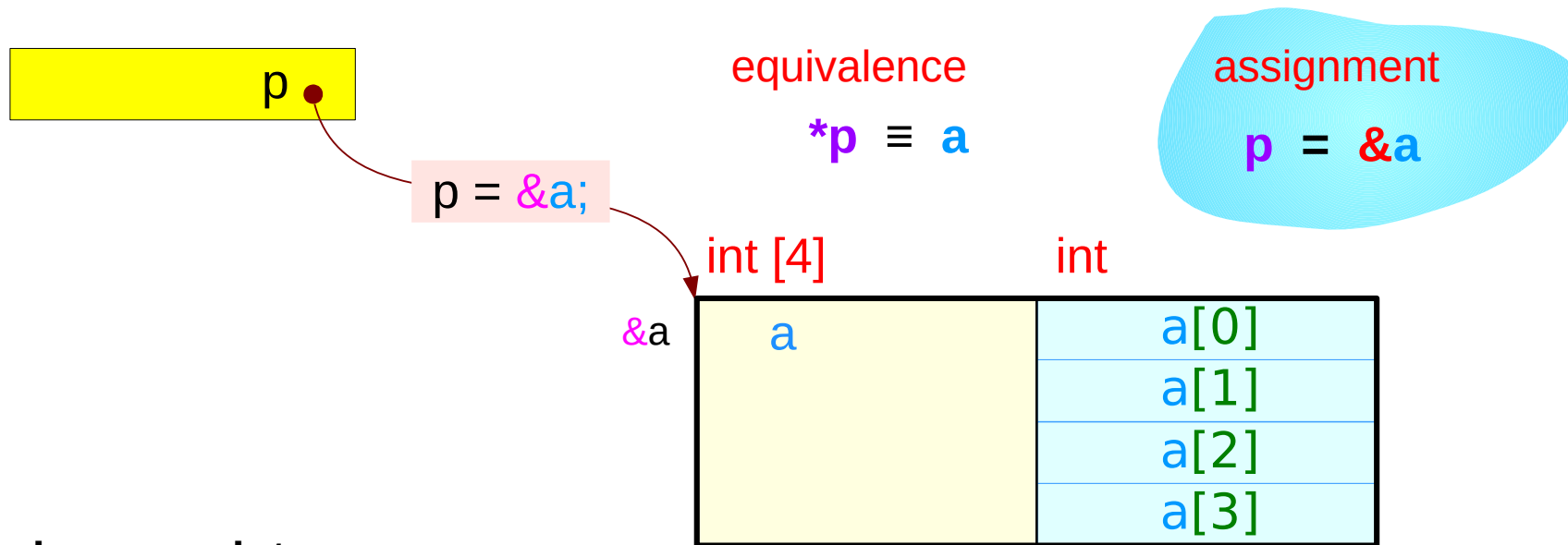

1-d array pointer

```
int (*p) [4];
```

1-d array

```
int c [4];
```

Pointer **q** to a 0-d array **a[0]**



q = c;

equivalence

$$*q \equiv a[0]$$

assignment

$$q = a$$

int (*)

int

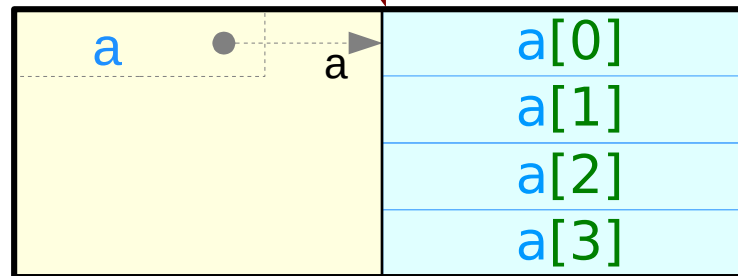

0-d array pointer

```
int (*q) [4];
```

1-d array

```
int a[4];
```

1-d array access using **p** and **q**

```
int (*p) [4] = &a;
```

```
int (*q) = a;
```

1-d array pointer

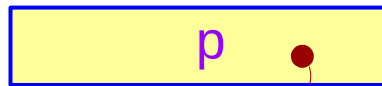

p = &a
assignment

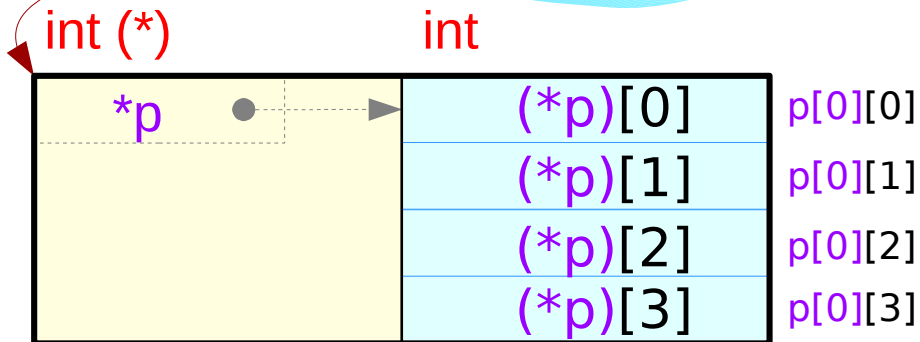

0-d array pointer

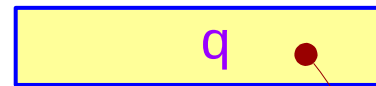

q = a
assignment

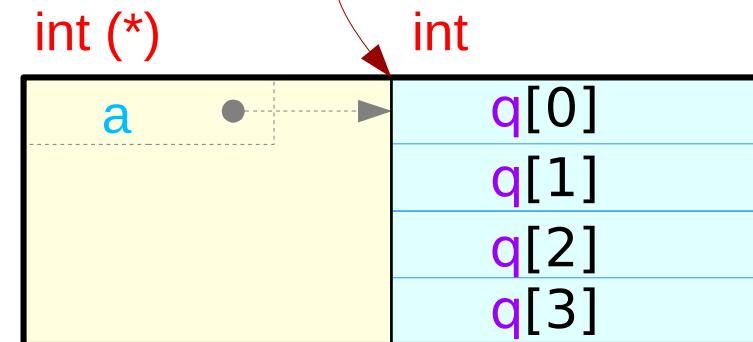

Pointer **p** to a 2-d array **c**

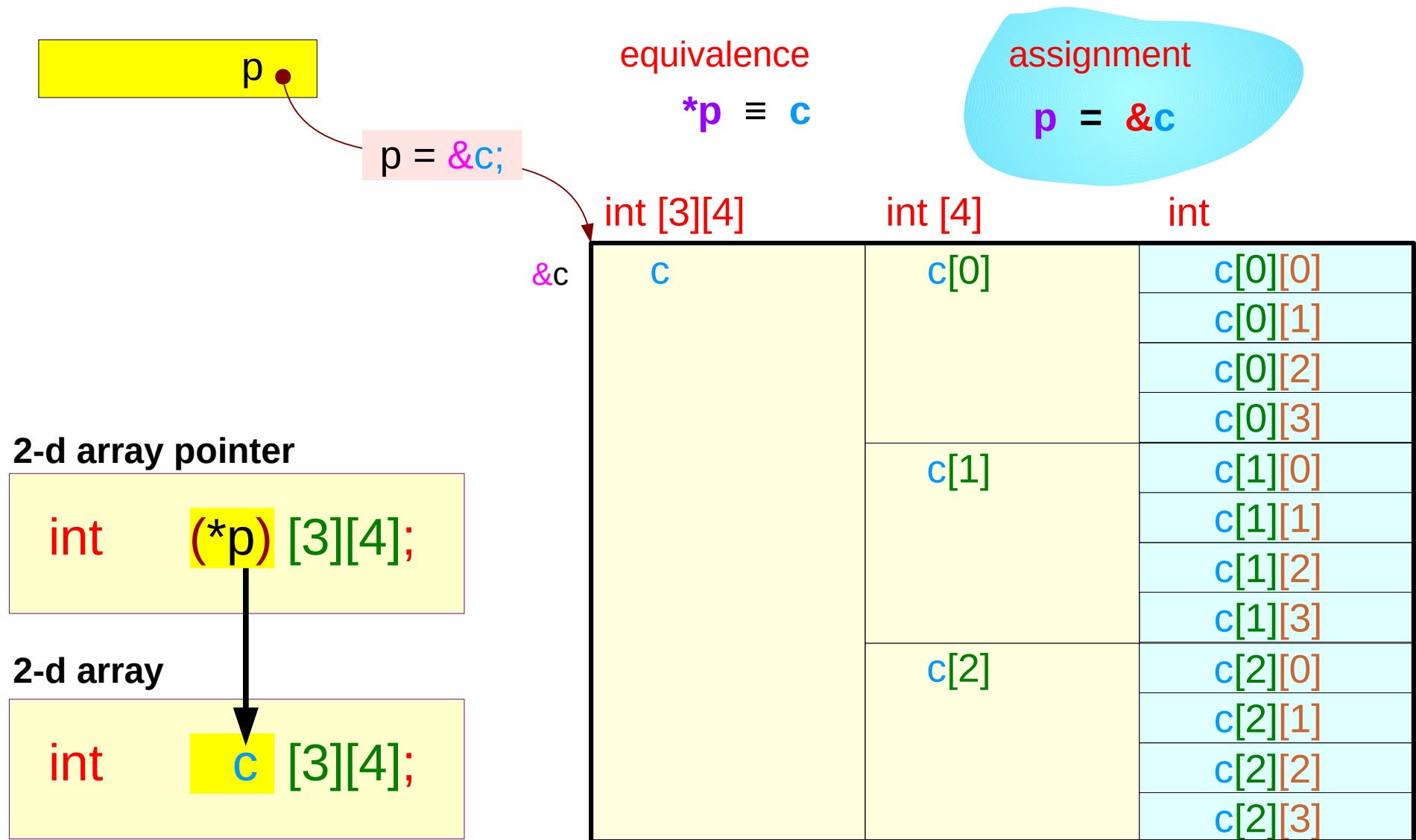

Pointer **q** to a 1-d array **c[0]**

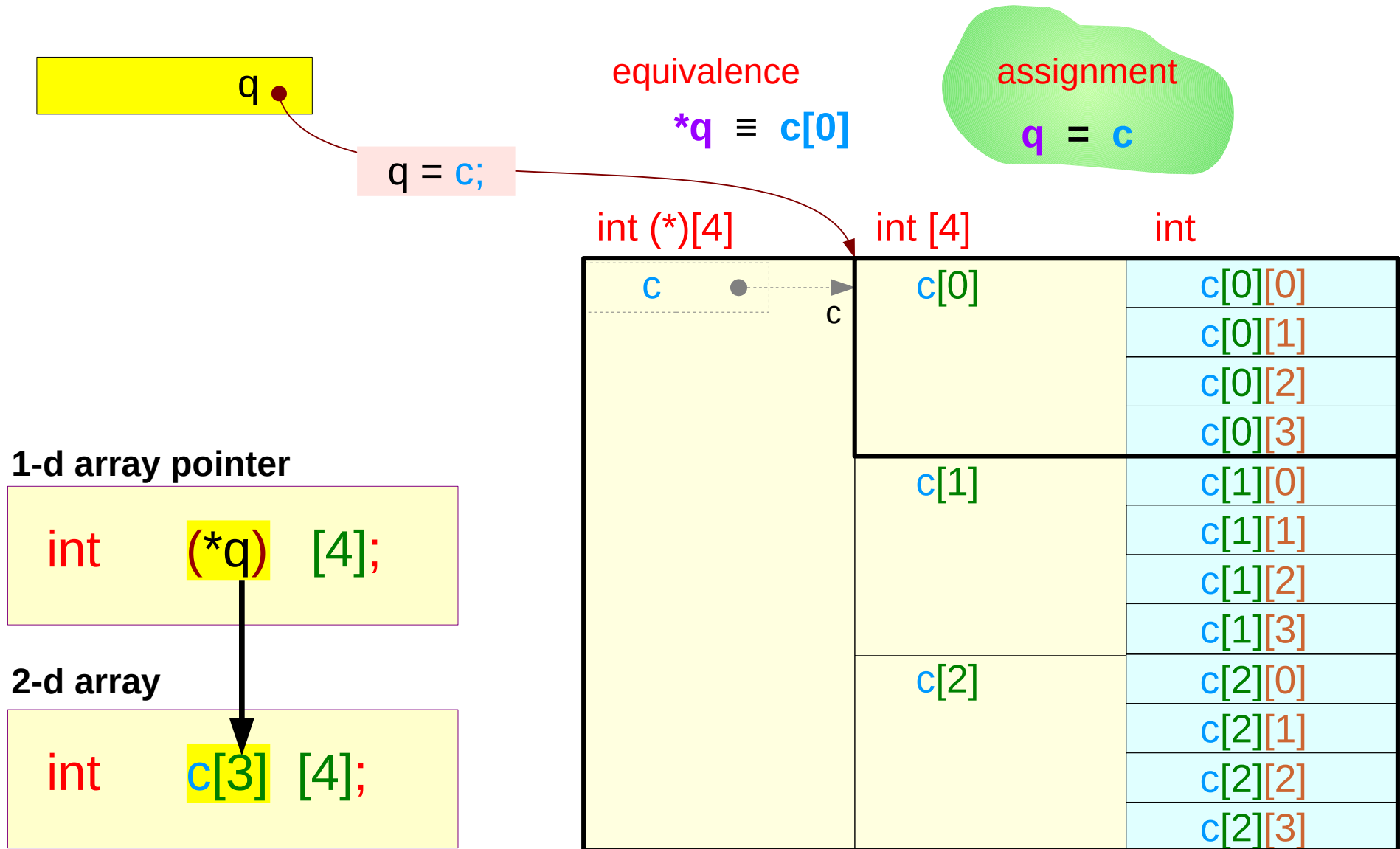

2-d array access using p



p = &c;

2-d array pointer

```
int (*p) [3][4] = &c;
```

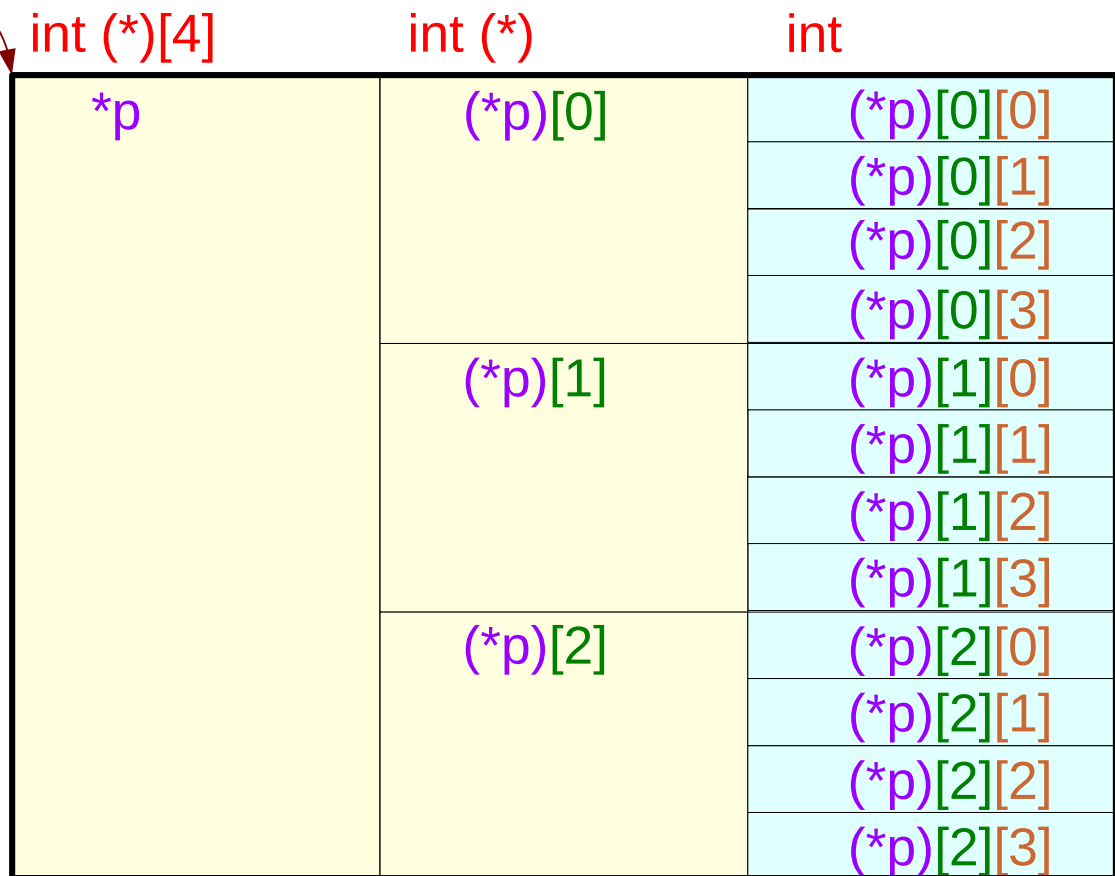

2-d array access using q

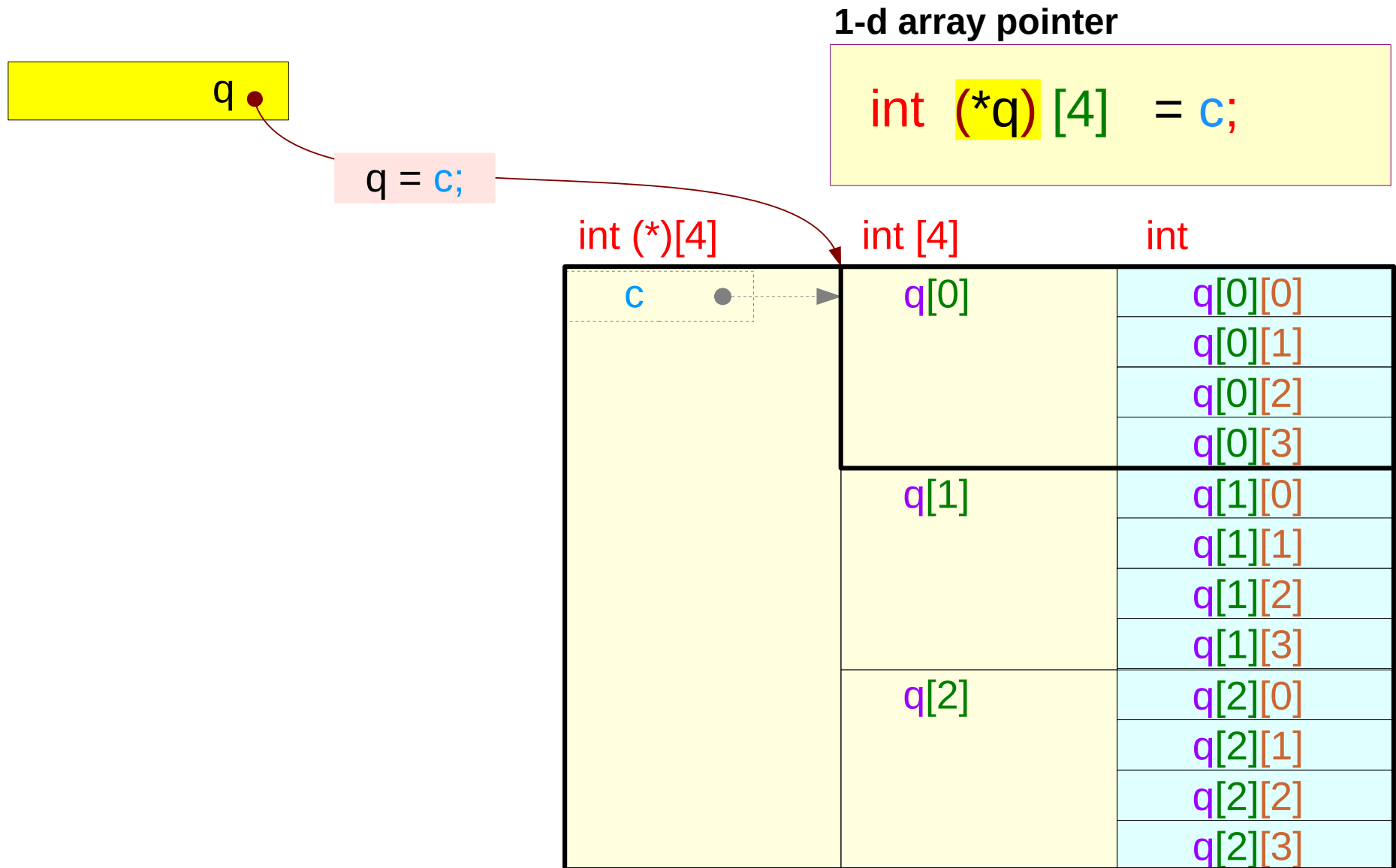

1-d and 0-d array pointers to an 1-d array

1-d array pointer

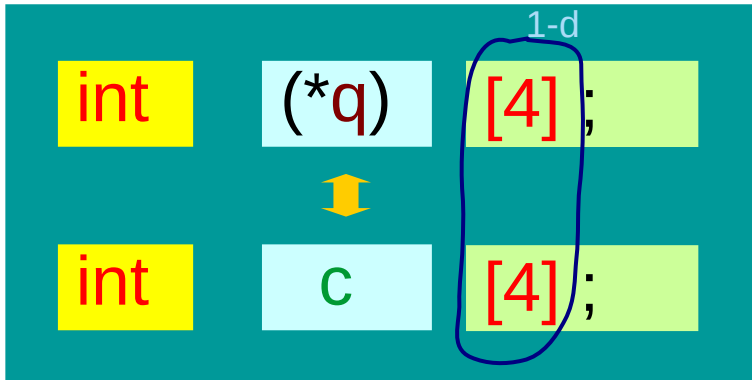

int (*) [4]

equivalence

`*q ≡ c;`

assignment

`q = &c;`

`(*q)[i] ≡ q[0][i] ≡ c[i]`

0-d array pointer : int pointer

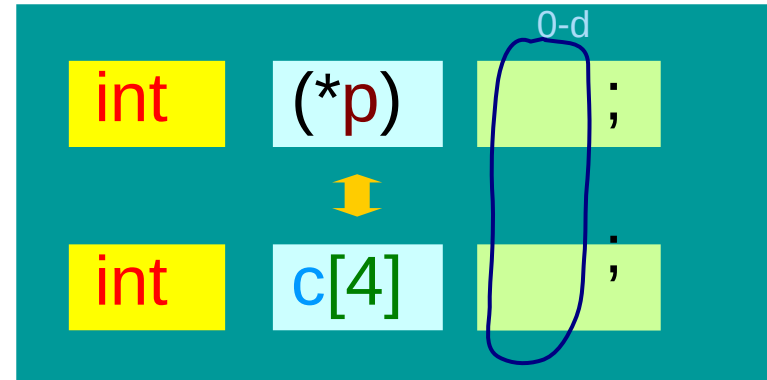

int (*)

equivalence

`*p ≡ *c;`

assignment

`p = c;`

`p[i] ≡ c[i]`

2-d and 1-d array pointers to a 2-d array

2-d array pointer

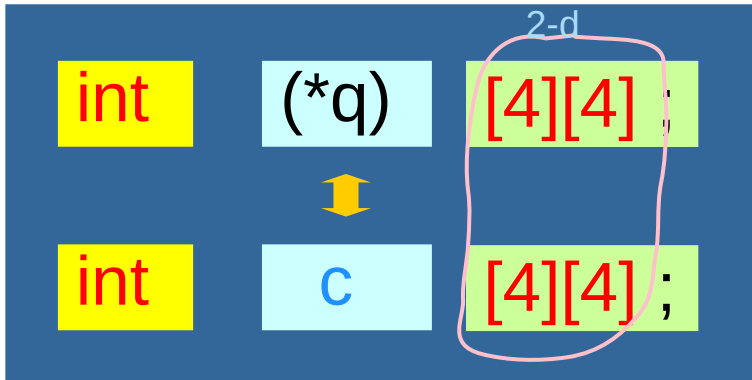

int (*) [4][4]

equivalence

`*q ≡ c;`

assignment

`q = &c;`

`(*q)[i][j] ≡ q[0][i][j] ≡ c[i][j]`

1-d array pointer

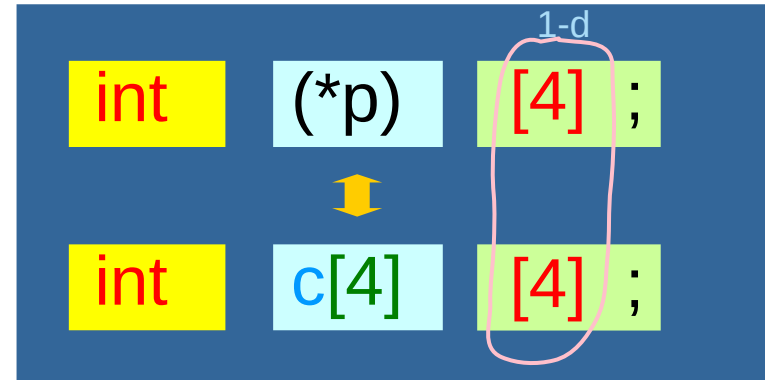

int (*) [4]

equivalence

`*p ≡ *c;`

assignment

`p = c;`

`p[i] ≡ c[i]`

Pointer to a 1-d array – (1) type declarations

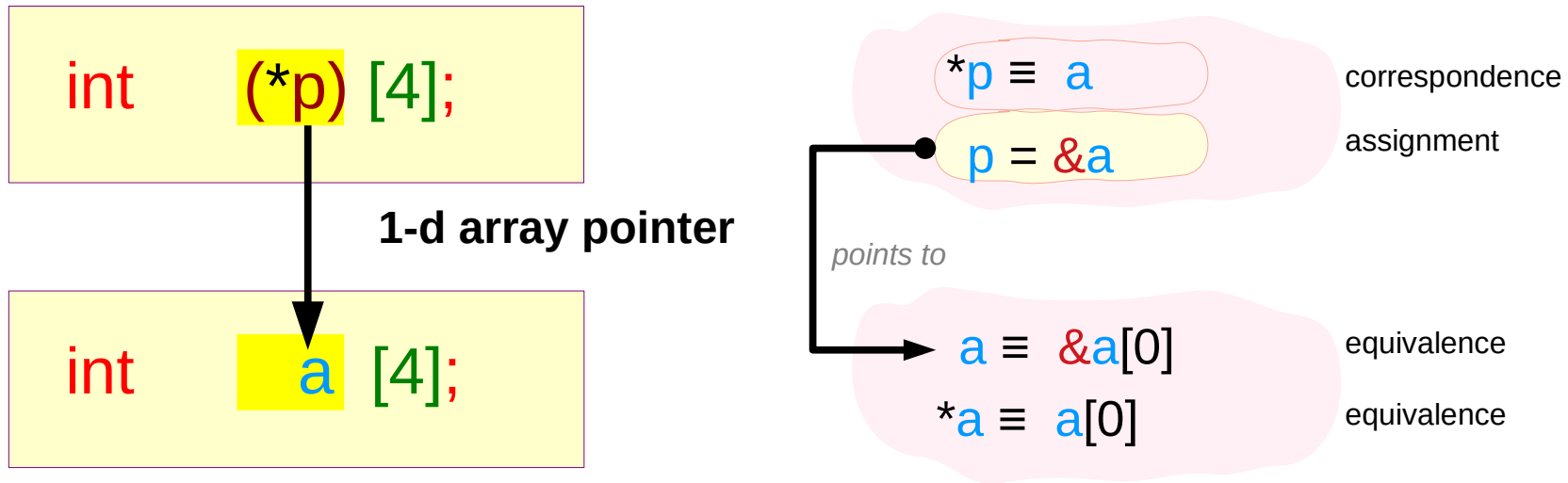

$\&a$ and a
print the same address
but have different types

$\text{value}(\&a) = \text{value}(a)$
 $\text{type}(\&a) \neq \text{type}(a)$

$\&a[0]$
 $\text{int} (*)[4] \neq \text{int} [4]$

those values are evaluated as addresses

Pointer to a 1-d array – (2) types and sizes

<code>int a [4];</code>	assignment	equivalence
<code>int (*p) [4];</code>	<code>p = &a</code>	<code>a ≡ &a[0]</code>

`int (*) [4]`

`sizeof(p) =`
4 or 8 bytes

size of a pointer

`int [4]` or `int (*)`

`sizeof(a) =`
4*4 bytes

not a real pointer `a`

`int`

`sizeof(a[0]) =`
4 bytes

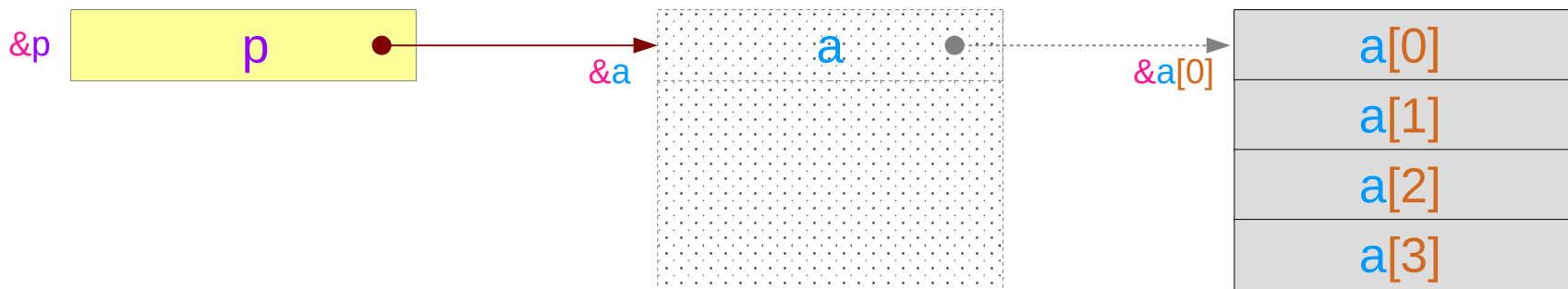

`value(&a) = value(a) = value(&a[0])`

not a real pointer `a`

Pointer to a 1-d array – (3) an assignment & equivalences

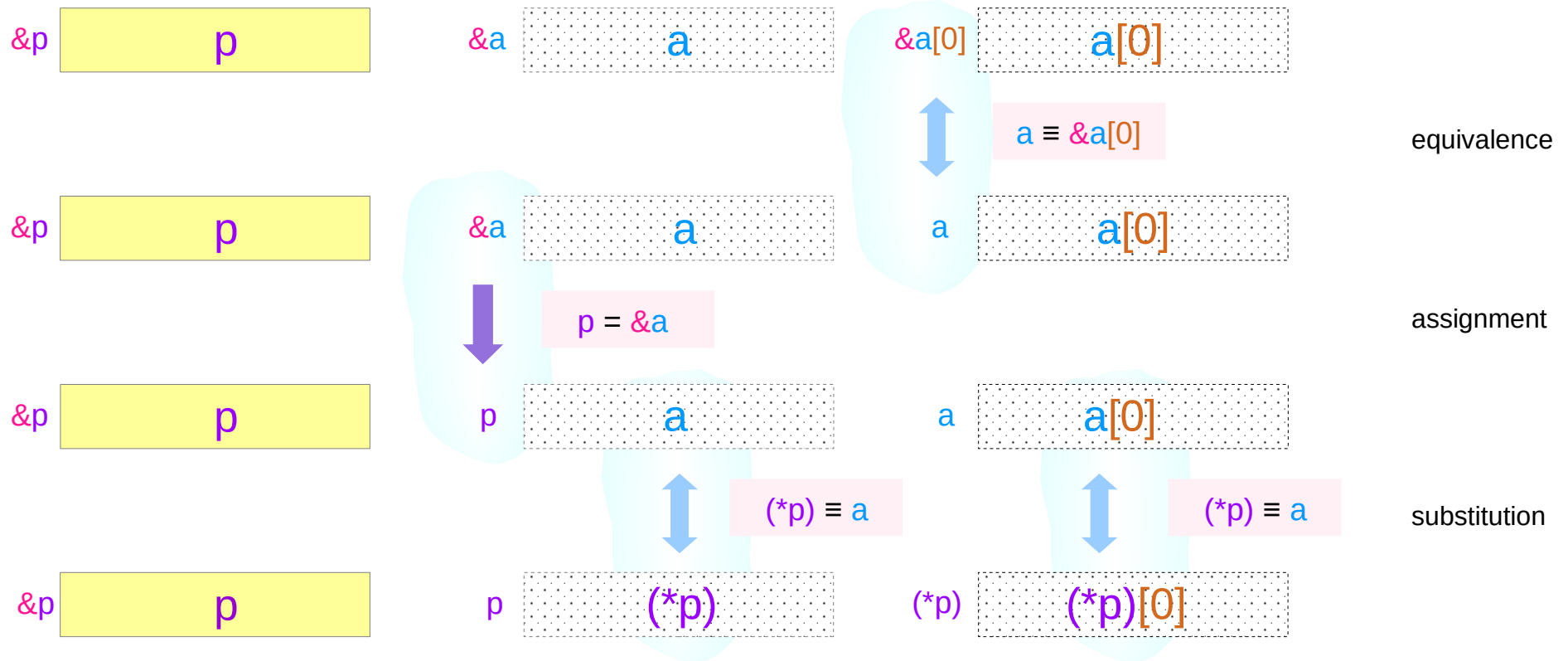

Pointer to a 1-d array – (4) a chain of pointers view

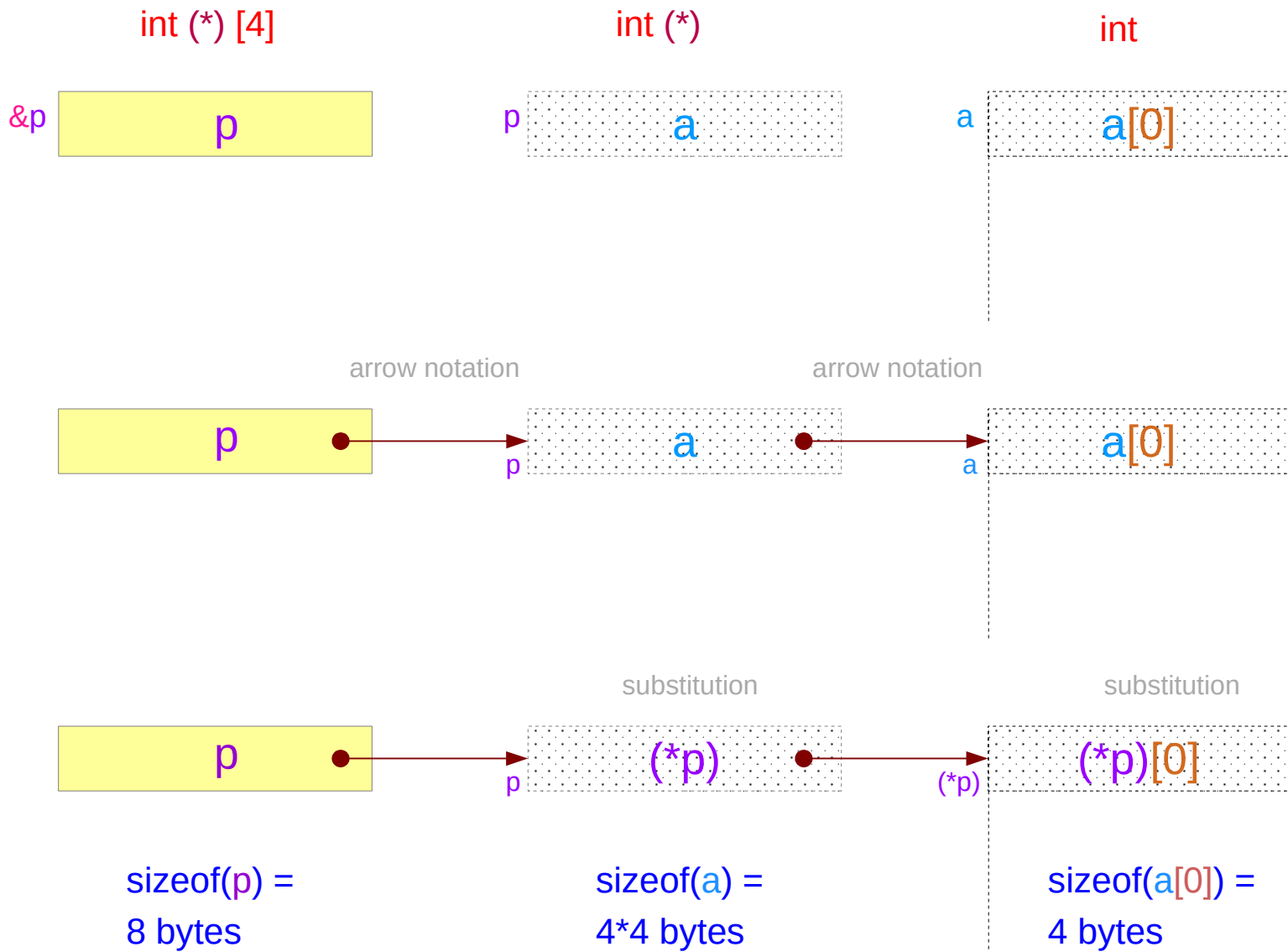

Pointer to a 2-d array – (1) type declarations

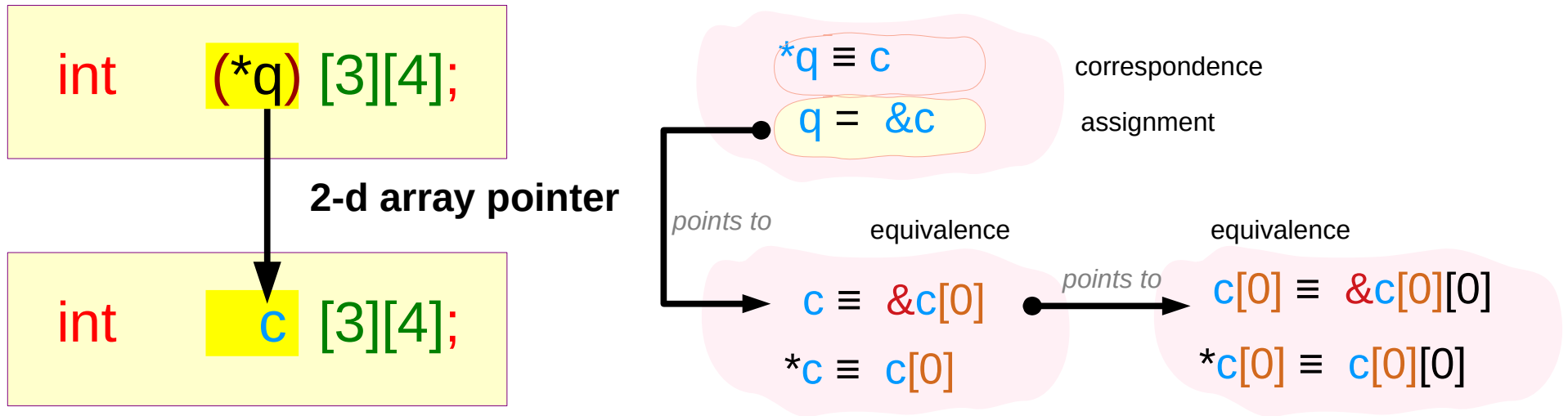

`&c, c, c[0]`
 print the same address
 but have different types

`value(&c) = value(c) = value(c[0])`
`type(&c) ≠ type(c) ≠ type(c[0])`

`&c[0][0]`

`int (*)[4][4] ≠ int [4][4]`
`int (*)[4] ≠ int [4]`

those values are evaluated as addresses

Pointer to a 2-d array – (2) types and sizes

<code>int c [3][4];</code>	assignment	equivalence	equivalence
<code>int (*q) [3][4];</code>	<code>q = &c</code>	<code>c ≡ &c[0]</code>	<code>c[0] ≡ &c[0][0]</code>

`int (*) [3][4]`

`sizeof(q) =`
8 bytes
size of a pointer

`int [3][4]` or `int (*) [4]`

`sizeof(c) =`
3*4*4 bytes
not a real pointer `c`

`int [4]` or `int (*)`

`sizeof(c[0]) =`
4*4 bytes
not a real pointer `c[0]`

`int`

`sizeof(c[0][0]) =`
4 bytes

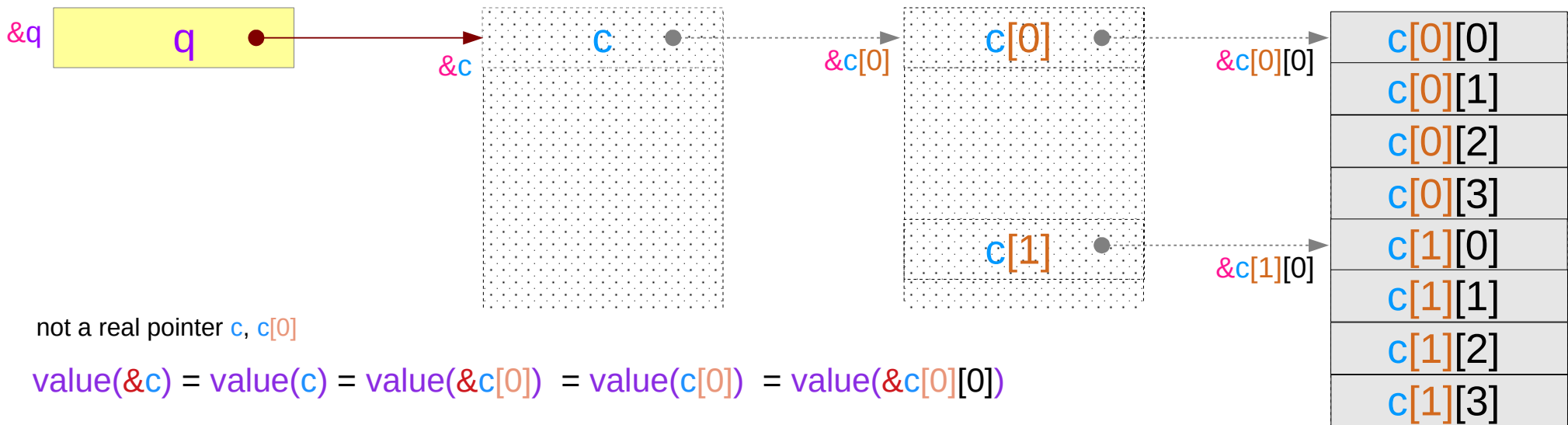

Pointer to a 2-d array – (3) an assignment & equivalences

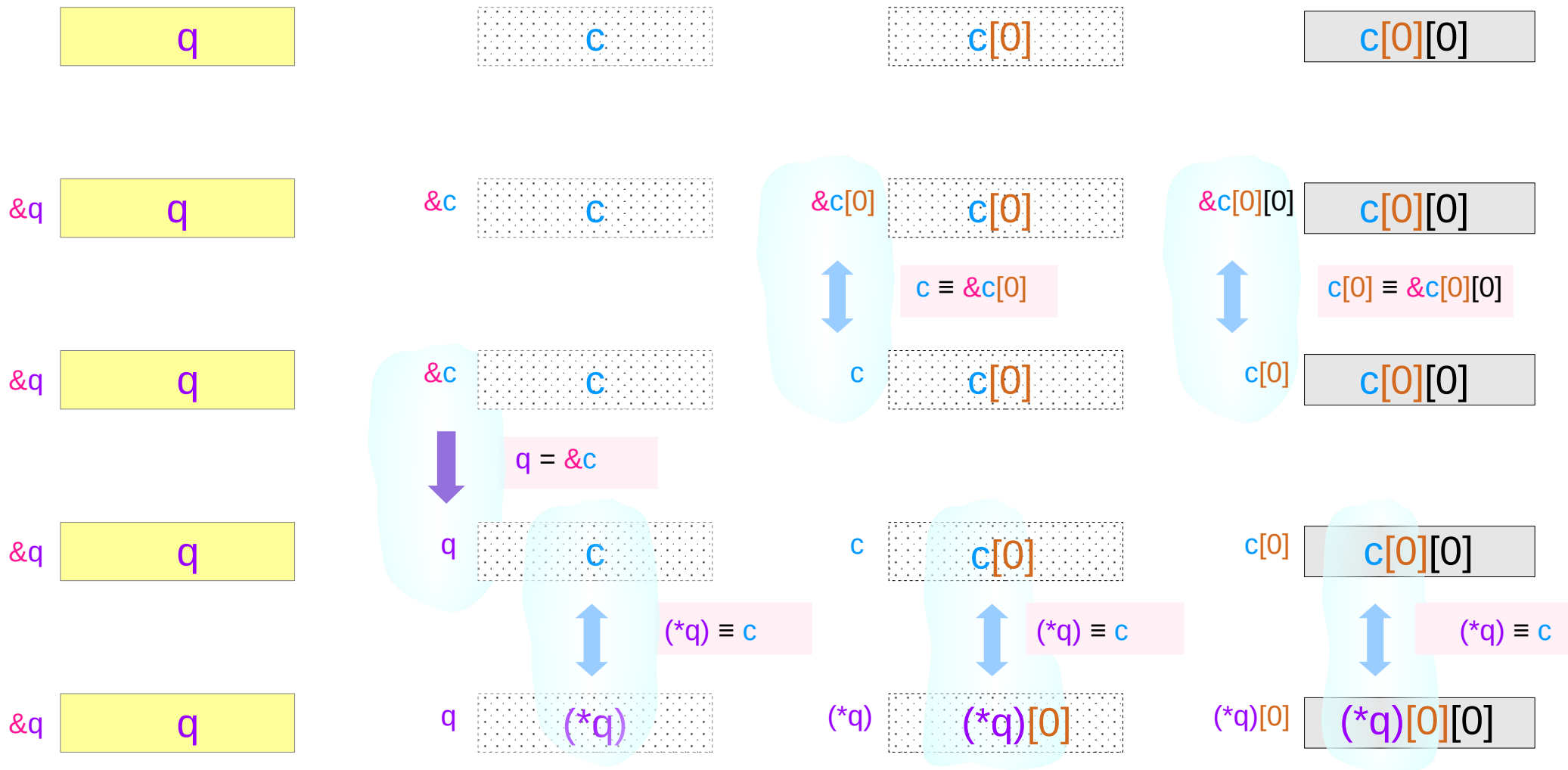

Pointer to a 2-d array – (4) a chain of pointers view

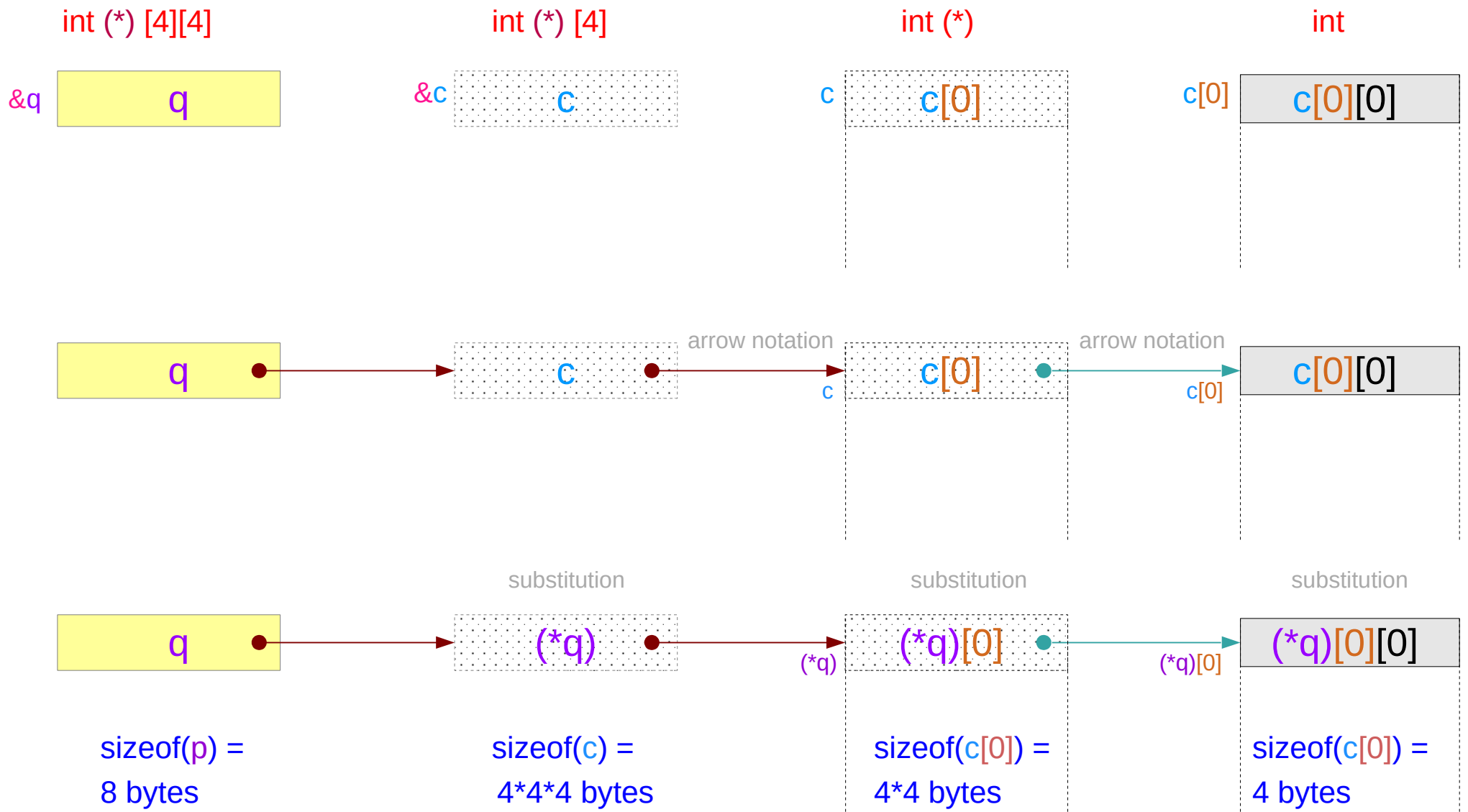

Array pointers to a 2-d array

```
int c [4] [4] ;  
int (*q) [4] [4] = &c ;  
int (*p) [4] = &c[0] ; (= c)
```

2-d array c

2-d array pointer q

1-d array pointer p

c[i][j] → (*q)[i][j]

c[i][j] → p[i][j]

int ** **→** **int *** **→** **int**

int (*) [4] **→** **int [4]** **→** **int**
int
int
int
int

Integer pointer **p** vs. array pointer **q**

```
int *p ;  
p = A ;
```

```
int (*q) [4];  
q = &A ;
```

int A[4] ;

int A[4] ;

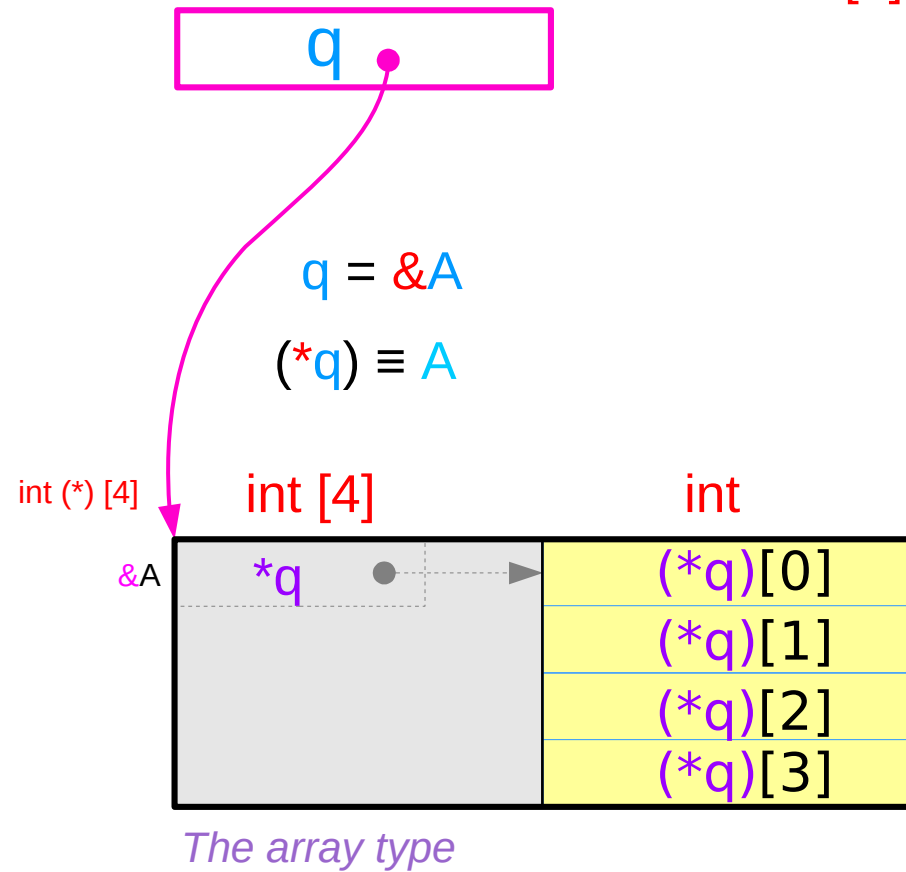
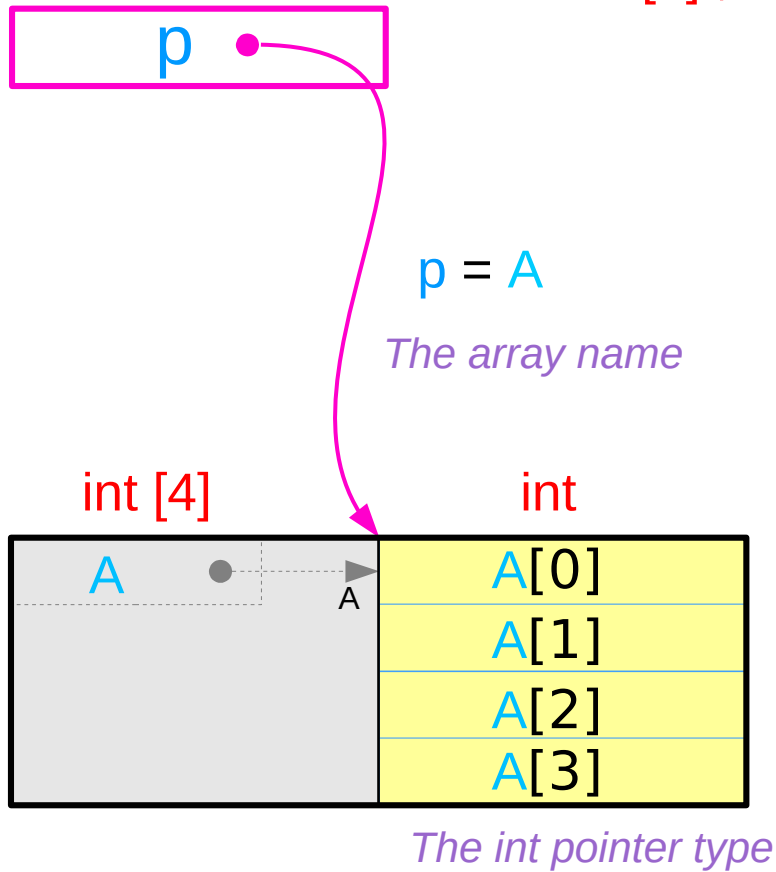

Must point to an array type (array name)

```
int (*q) [4];
```

```
q = A ;
```

```
int A[4];
```



Warning!

q=A

The array name

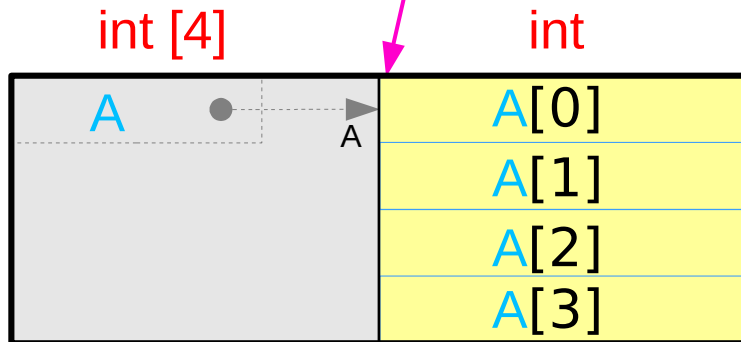

The array type

```
int (*q) [4];
```

```
q = &A ;
```

```
int A[4];
```



q=&A

(*q) ≡ A

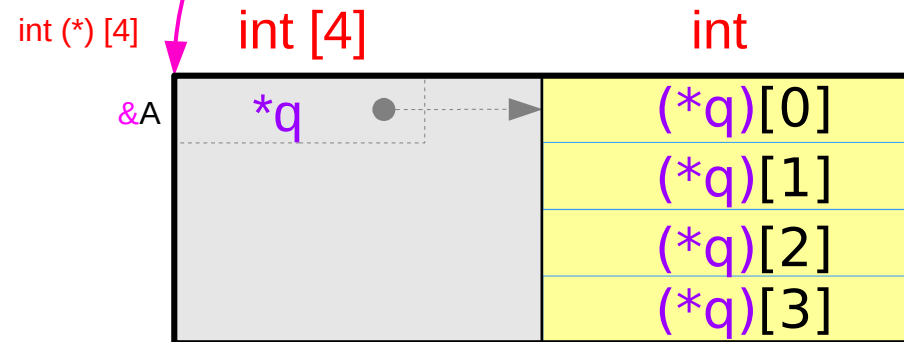

The array type

Double integer pointer type – `int **`

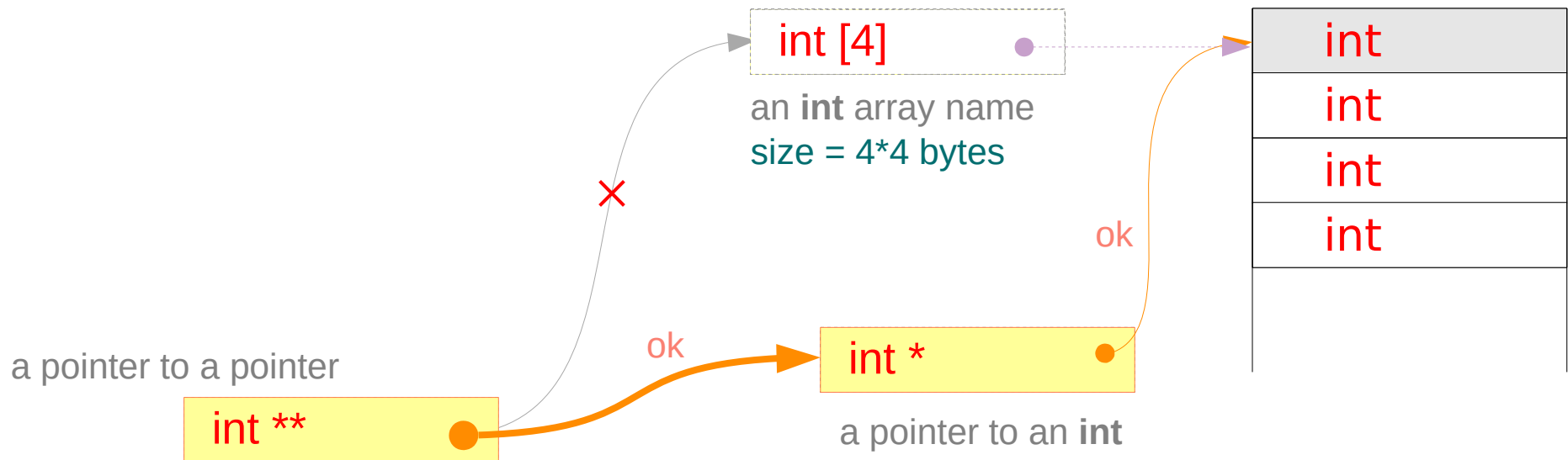

`int **` type can point only to `int *` type – an `int` array name (X)

`type(int [4]) = type(int []) = int *`
each of these types points to an `int` type data

Integer array pointer type – `int (*)[4]`

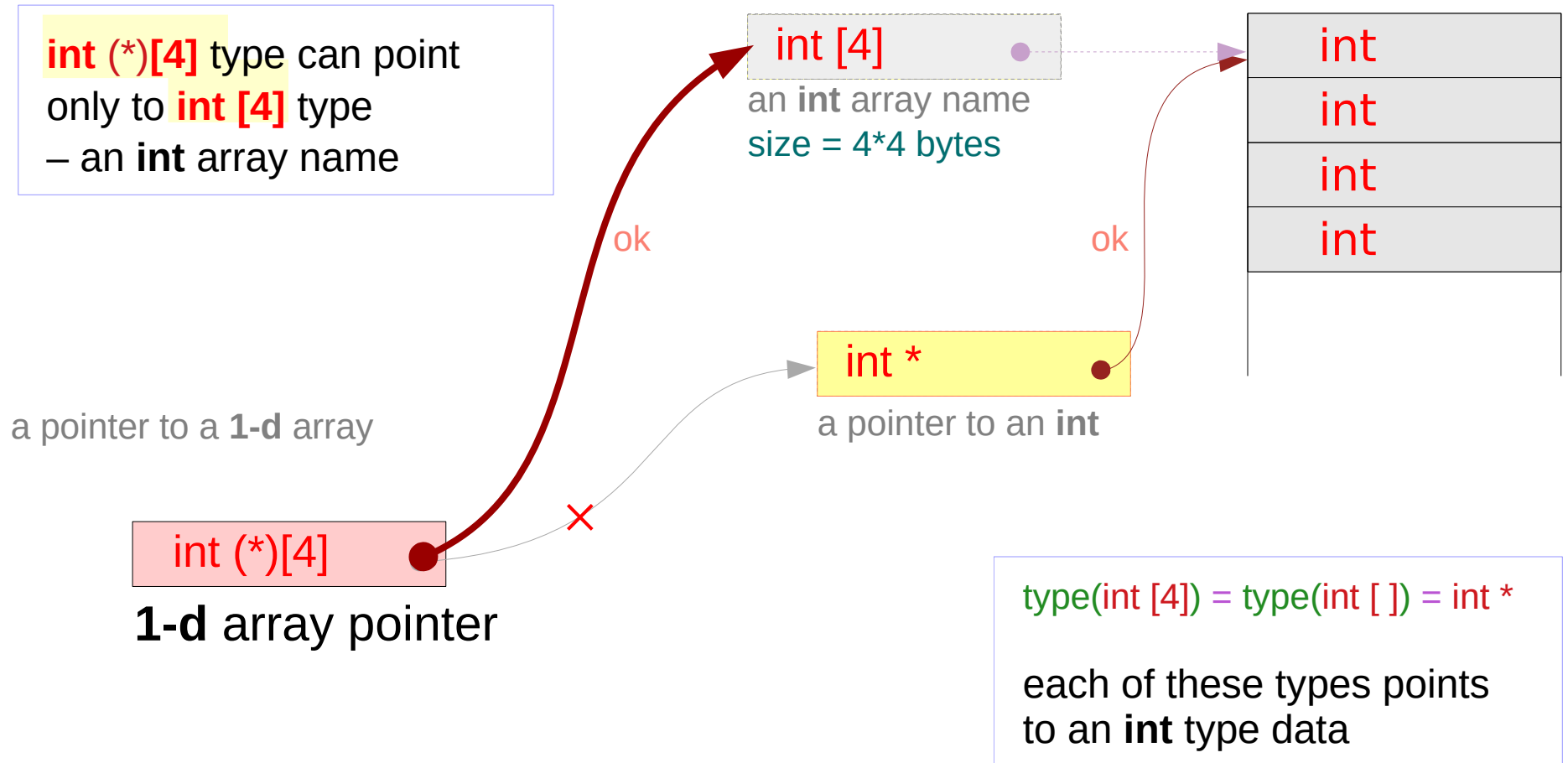

Types of integer pointers

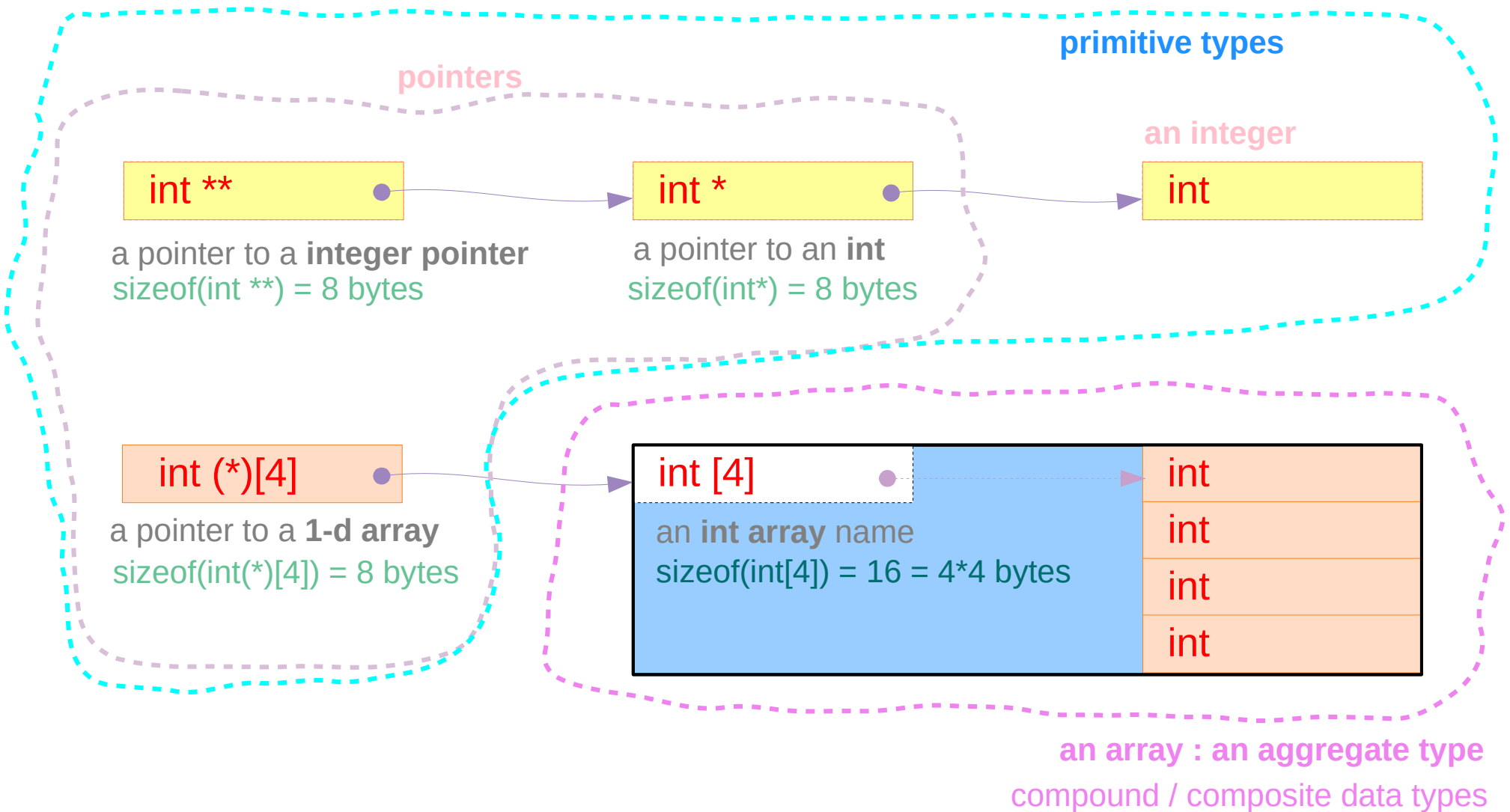

Variable declaration of integer pointers

`int *q = &p;`

`int *p = &a;`

`int a;`

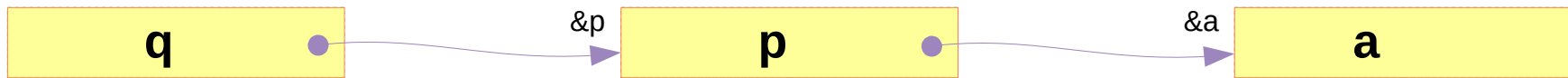

`int (*r)[4] = &c;`

`int c[4];`

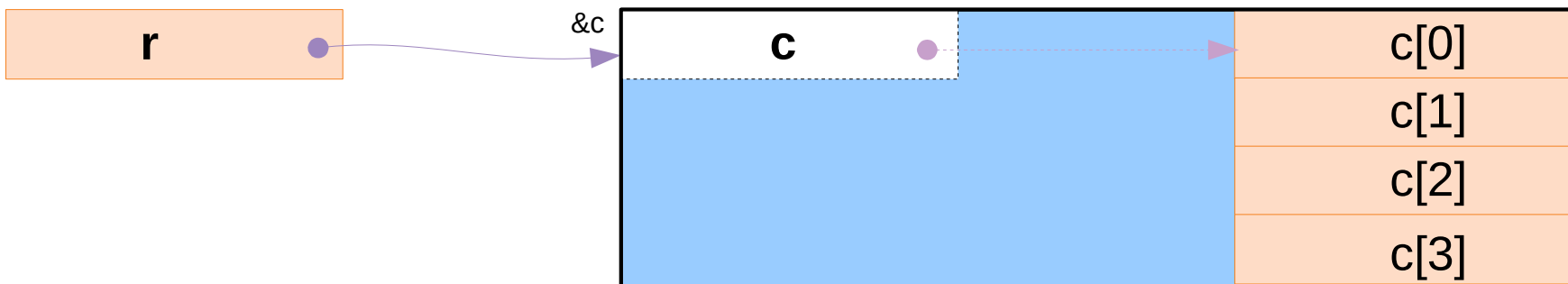

Types and sizes of integer pointers

`type(int [4]) = type(int []) = (int *)`

```
int a;  
int *p = &a;  
int *q = &p;
```

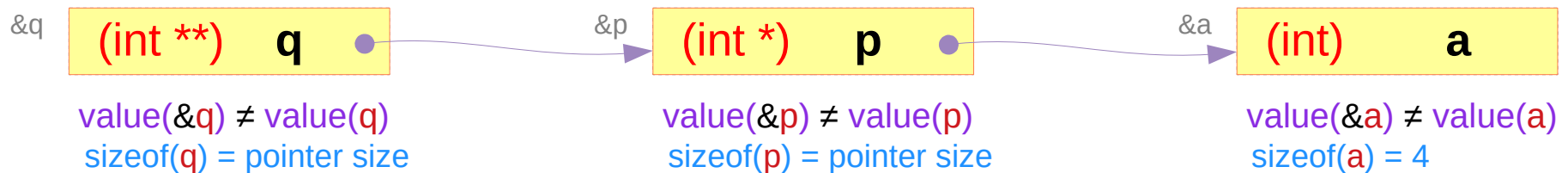

```
int c[4];  
int (*r)[4] = &c;
```

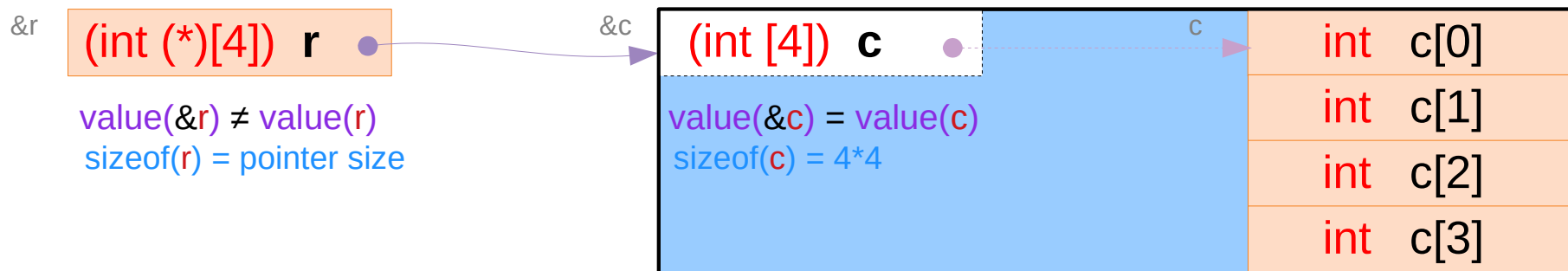

Sizes of integer pointers

a pointer to an `int`

`sizeof(p)` = pointer size
= 8 bytes on 64-bit machine
= 4 bytes on 32-bit machine

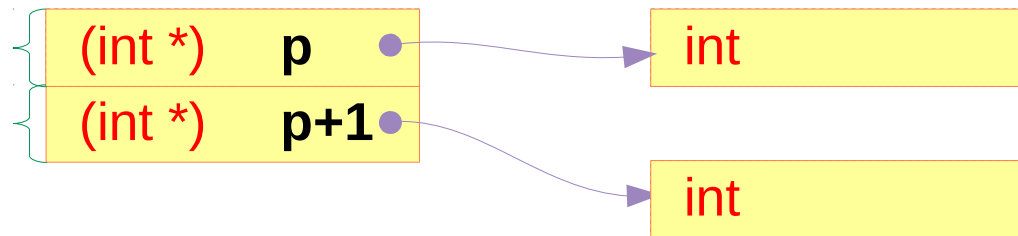

an `int` array name

an array :
an aggregate type

`sizeof(c)`
= `sizeof(*c) * 4`
= `sizeof(int) * 4`
= $4 * 4 = 16$ bytes

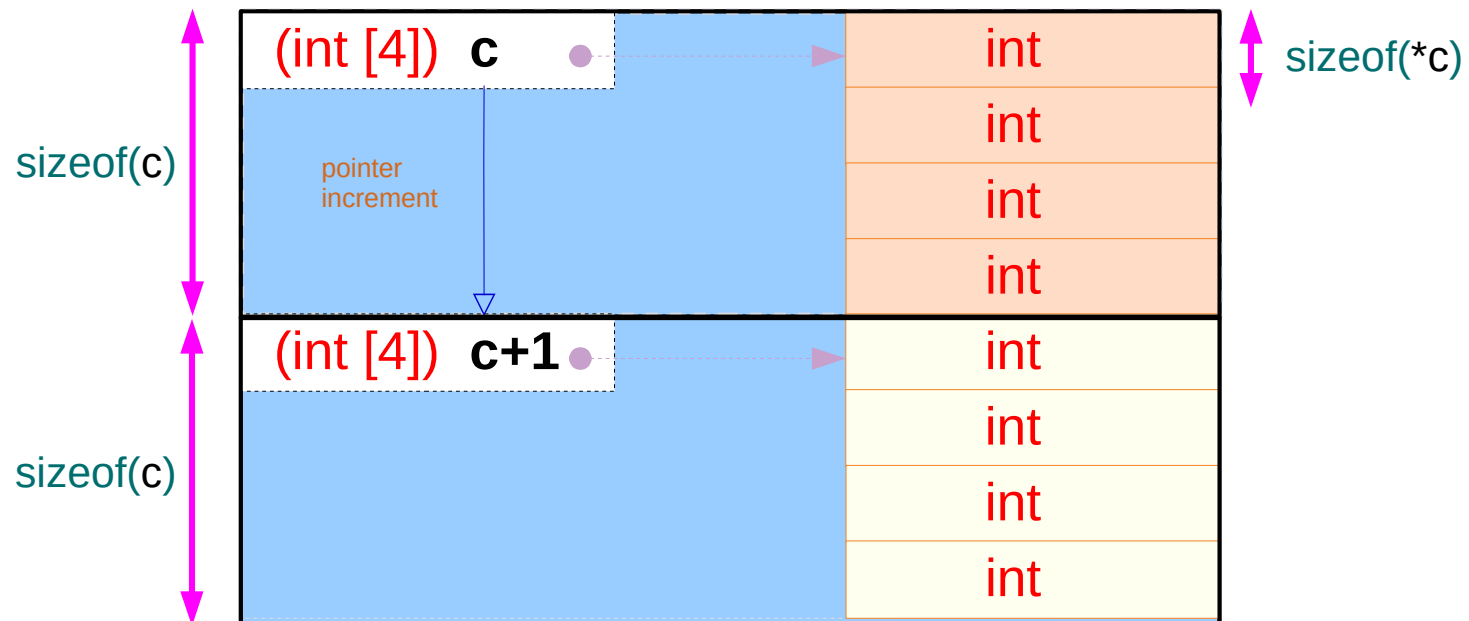

`type(int [4]) = type(int []) = (int *)`

Integer pointer and array types – `int *`, `int [2]`, `int [3]`

`int *a;`



`int b[2];`

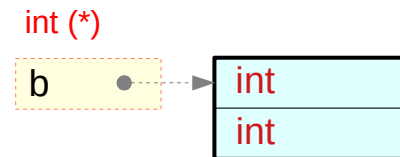
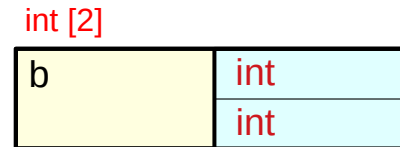

`int [2]` – size view
`int (*)` – address view

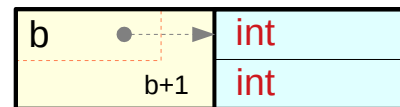

`int c[3];`

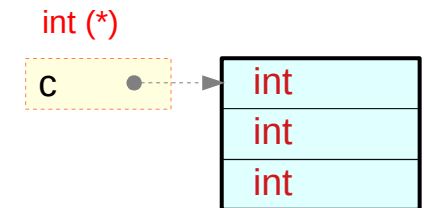
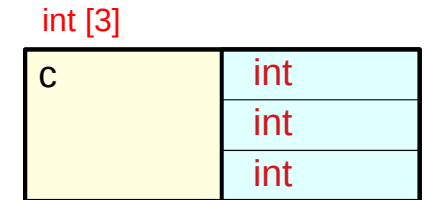

`int [3]` – size view
`int (*)` – address view

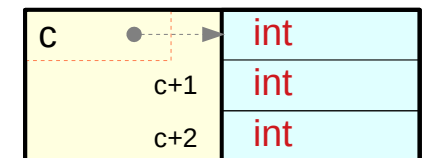

Integer pointer and array types – `int *`, `int [2]`, `int [3]`

`int *a;`

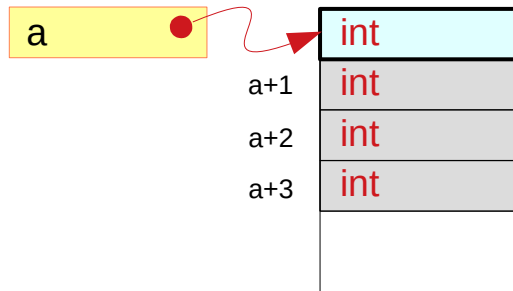

```
a[0] = *a  
a[1] = *(a+1)  
a[2] = *(a+2)  
a[3] = *(a+3)
```

syntactically legitimate

programmers must ensure their validity

`int b[2];`

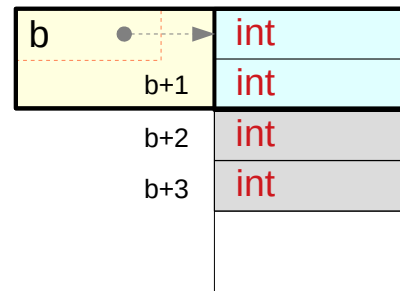

```
b[0] = *b  
b[1] = *(b+1)  
b[2] = *(b+2)  
b[3] = *(b+3)
```

syntactically legitimate

programmers must ensure their validity

`int c[3];`

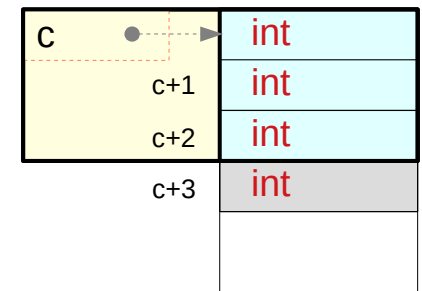

```
c[0] = *c  
c[1] = *(c+1)  
c[2] = *(c+2)  
c[3] = *(c+3)
```

syntactically legitimate

programmers must ensure their validity

Integer pointer and array types – `int *`, `int [2]`, `int [3]`

`int *a;`

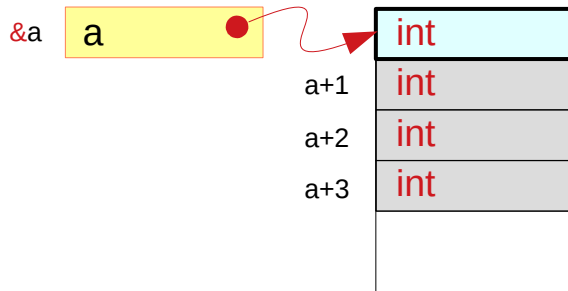

`type(&a) = int **`

`type(a) = int *`

`type(*a) = int`

`value(&a) ≠ value(a)`

`sizeof(a)`

= pointer size

= `sizeof(int *)`

`int b[2]`

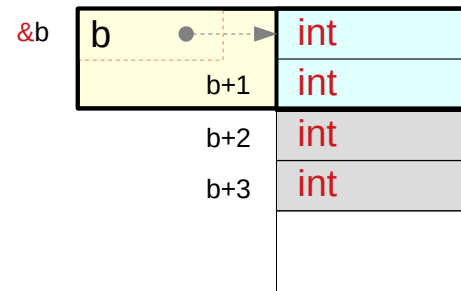

`type(&b) = int (*) [2]`

`type(b) = int [2]`
`int (*)`

`type(*b) = int`

`value(&b) = value(b)`

`sizeof(b)`

= `sizeof(*b) * 2`

= `sizeof(int) * 2`

`&b` and `b` evaluate the same address but have different types and also different sizes

`int c[3];`

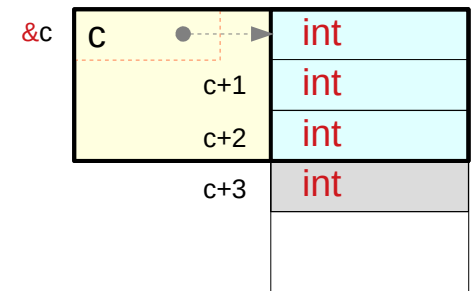

`type(&c) = int (*) [3]`

`type(c) = int [3]`
`int (*)`

`type(*c) = int`

`value(&c) = value(c)`

`sizeof(c)`

= `sizeof(*c) * 3`

= `sizeof(int) * 3`

`&c` and `c` evaluate the same address but have different types and also different sizes

Integer pointer and array types – `int *`, `int [3]`

`int *a;`

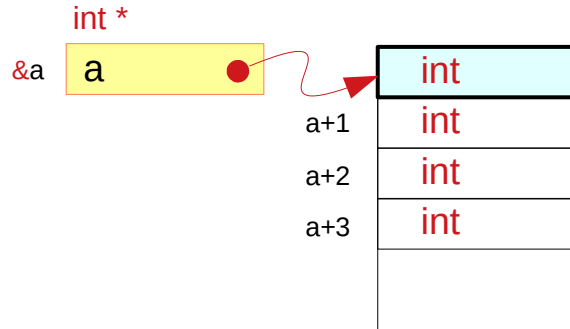

`sizeof (a) = pointer size` `int *`

`value(&a) ≠ value(a)` `int *`

the address of pointer variable `a` is not equal to the pointed address

real memory location for `a`

`a` `:: int *`
`&a` `:: int **`

`int c[3];`

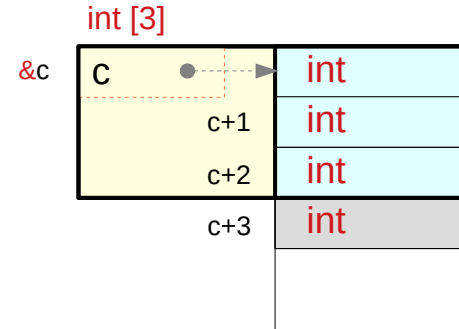

`sizeof (c) = sizeof(*c) * 3` `int [3]`

`value(&c) = value(c)` `int (*)`

the starting address of array variable `c` is equal to the address of the 1st element

no actual memory location for `c`

`c` `:: int [3]`
`&c` `:: int (*) [3]`

Integer pointer and array types – `int [3]`

`int c[3];`

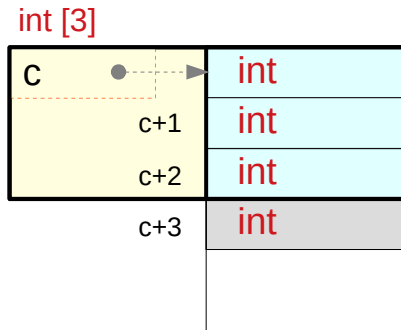

`sizeof (c) = sizeof(int) * 3`

`value(&c) = value(c)`

`type(c) = int *`

`type(&c) = int (*) [3]`

`int c[3];`

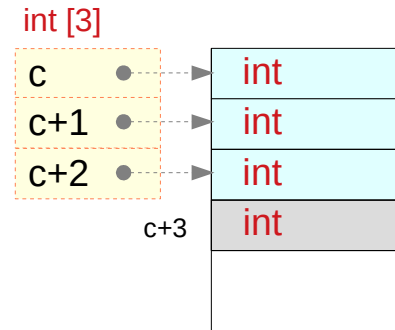

`sizeof (c) = sizeof(*c) * 3` ... leading element

`sizeof (c+1) = pointer size`

`sizeof (c+2) = pointer size`

`value(&c) = value(c)` ... leading element

`value(c+1) = value(c) + sizeof(*c) * 1`

`value(c+2) = value(c) + sizeof(*c) * 2`

`type(c) = int *`

`type(c+1) = int *`

`type(c+2) = int *`

`type(&c) = int (*) [3]`

Virtual pointer p in an aggregated data

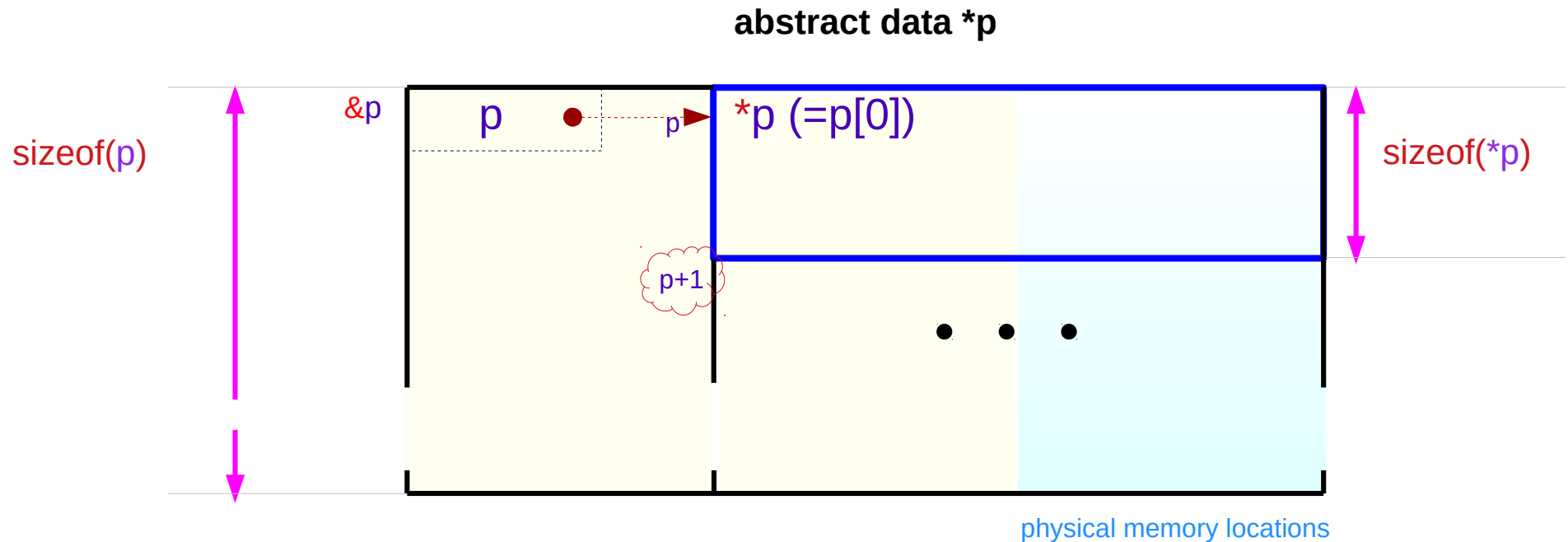

size view $p[N][] \dots []$

$$\text{sizeof}(p) = \text{sizeof}(*p) * N$$

$$\text{value}(p+1) = \text{value}(p) + \text{sizeof}(*p)$$

address view $(*p)[] \dots []$

$$\text{value}(\&p) = \text{value}(p)$$

Virtual pointer p in an aggregated data

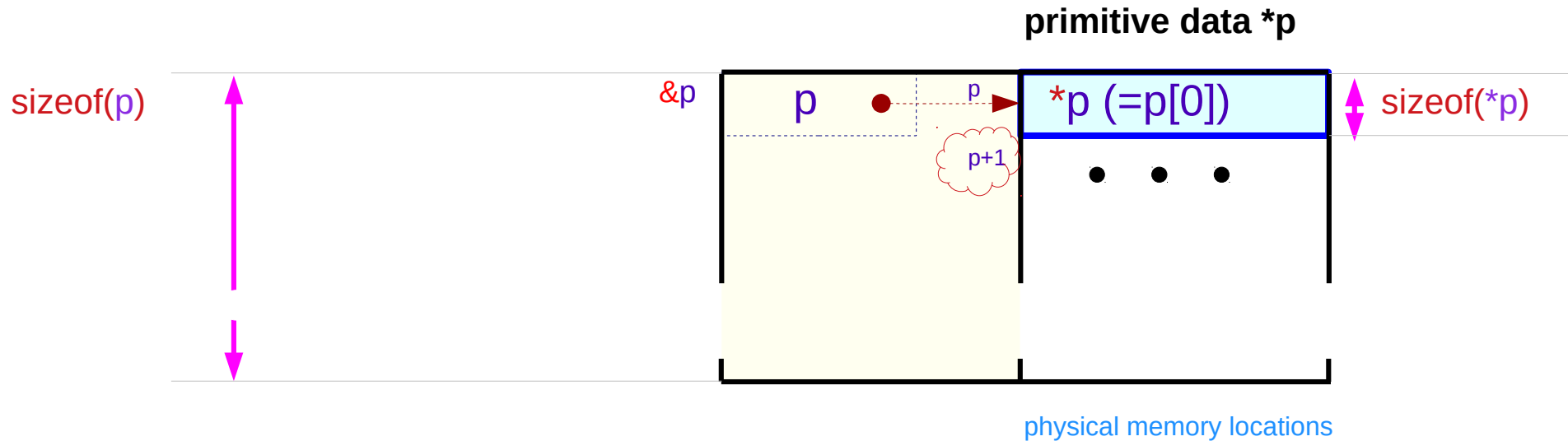

size view $p[N][] \dots []$

$$\text{sizeof}(p) = \text{sizeof}(*p) * N$$

$$\text{value}(p+1) = \text{value}(p) + \text{sizeof}(*p)$$

address view $(*p)[] \dots []$

$$\text{value}(\&p) = \text{value}(p)$$

Real pointers

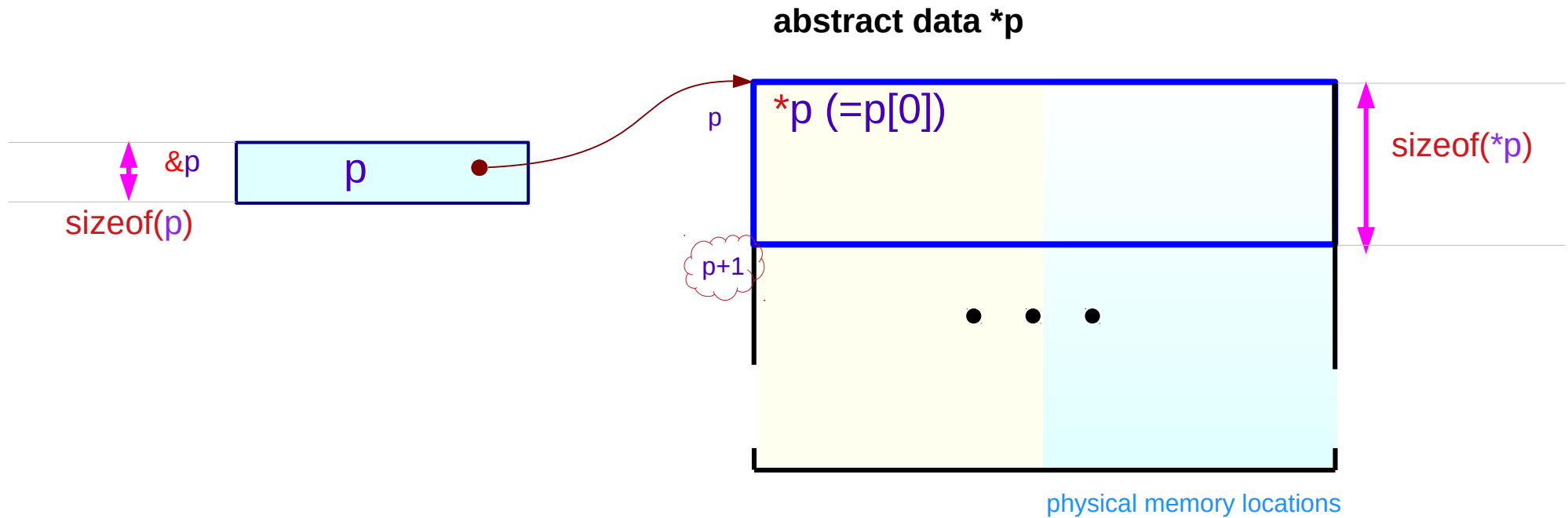

`sizeof(p)` = pointer size (4/8 bytes)

`value(p+1)` = `value(p)` + `sizeof(*p)`

`value(&p)` \neq `value(p)`

Real pointers

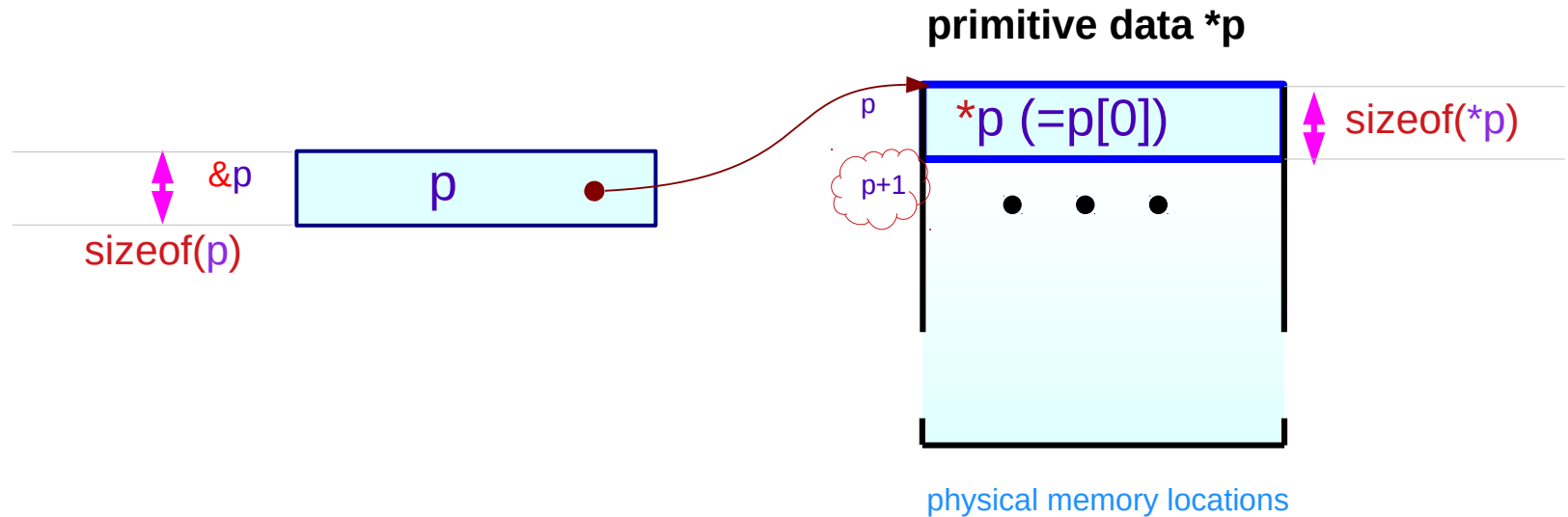

$\text{sizeof}(p)$ = pointer size (4/8 bytes)

$\text{value}(p+1) = \text{value}(p) + \text{sizeof}(*p)$

$\text{value}(\&p) \neq \text{value}(p)$

Incrementing a 1-d array pointer

```
int (*p) [4];
```

$$\begin{aligned} \text{value}(p+1) - \text{value}(p) &= \text{sizeof}(*p) \\ &= (\text{long}) (p+1) - (\text{long}) (p) \\ &= 4 * \text{sizeof}(\text{int}) \end{aligned}$$

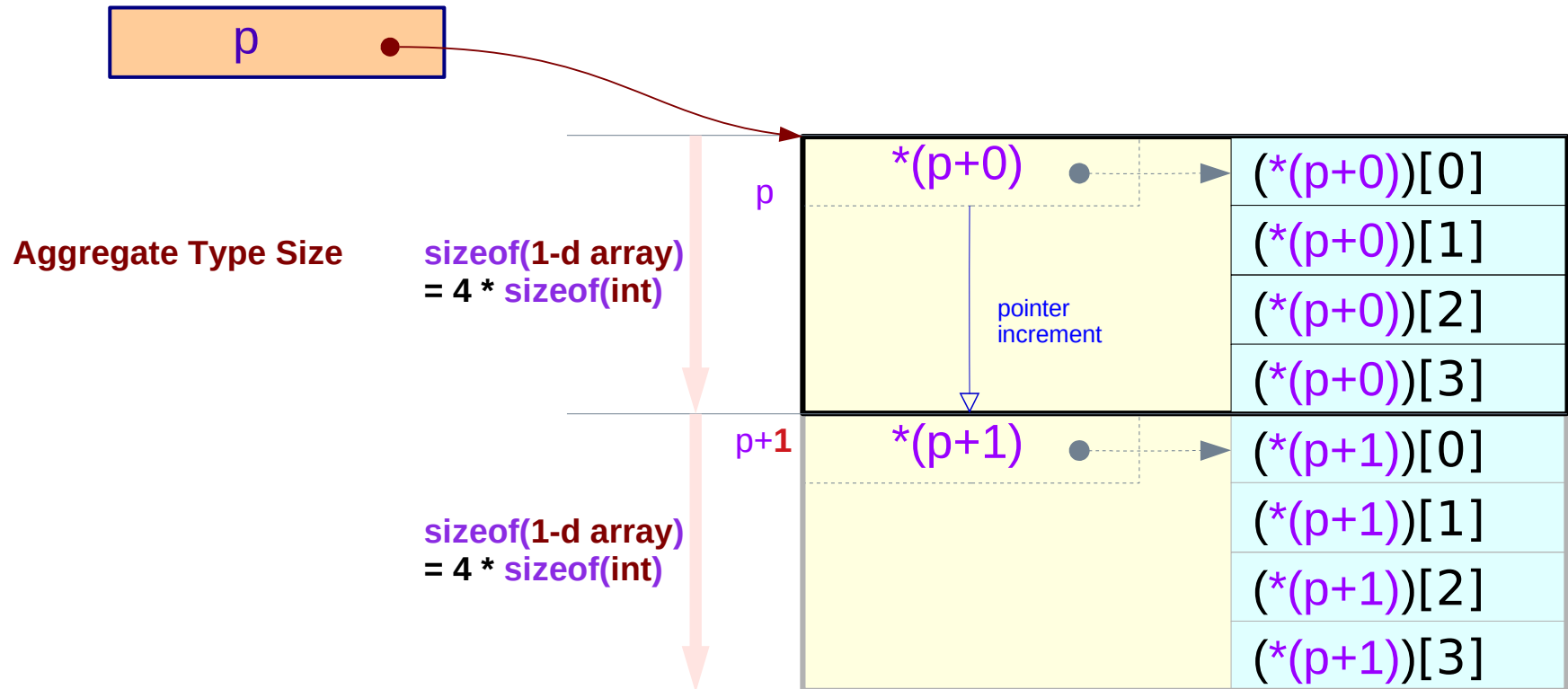

Equivalence : $*(p+i) = p[i]$

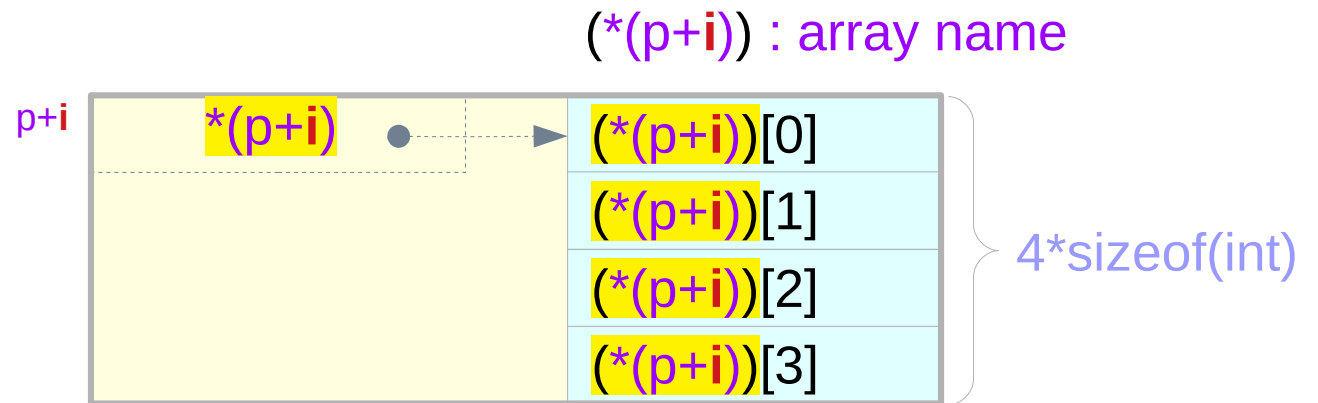

$$*(p+i) \equiv p[i]$$

|| equivalence

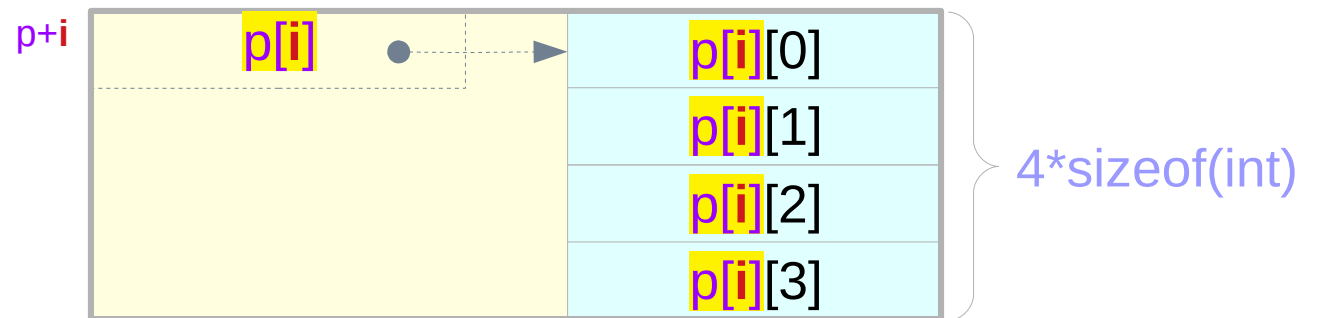

$p[i]$: 1-d array name

Incrementing a pointer to a 1-d array

```
int (*p) [4] = c;
```

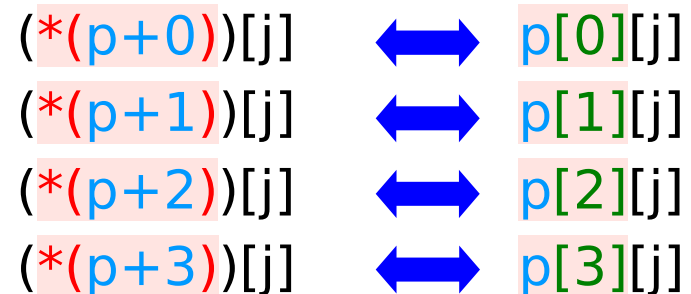
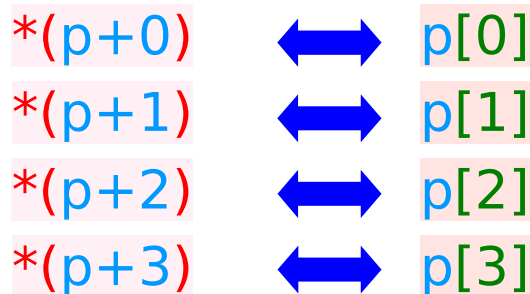
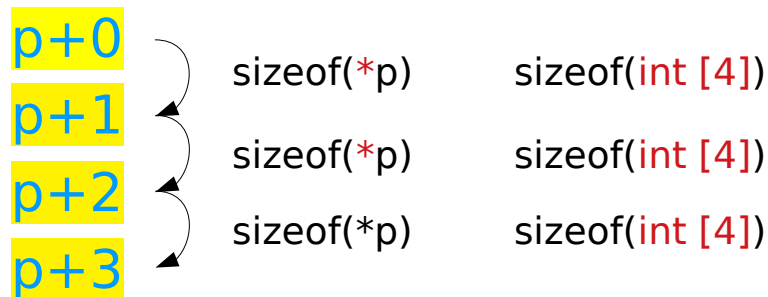

Accessing a 2-d array using a 1-d array pointer

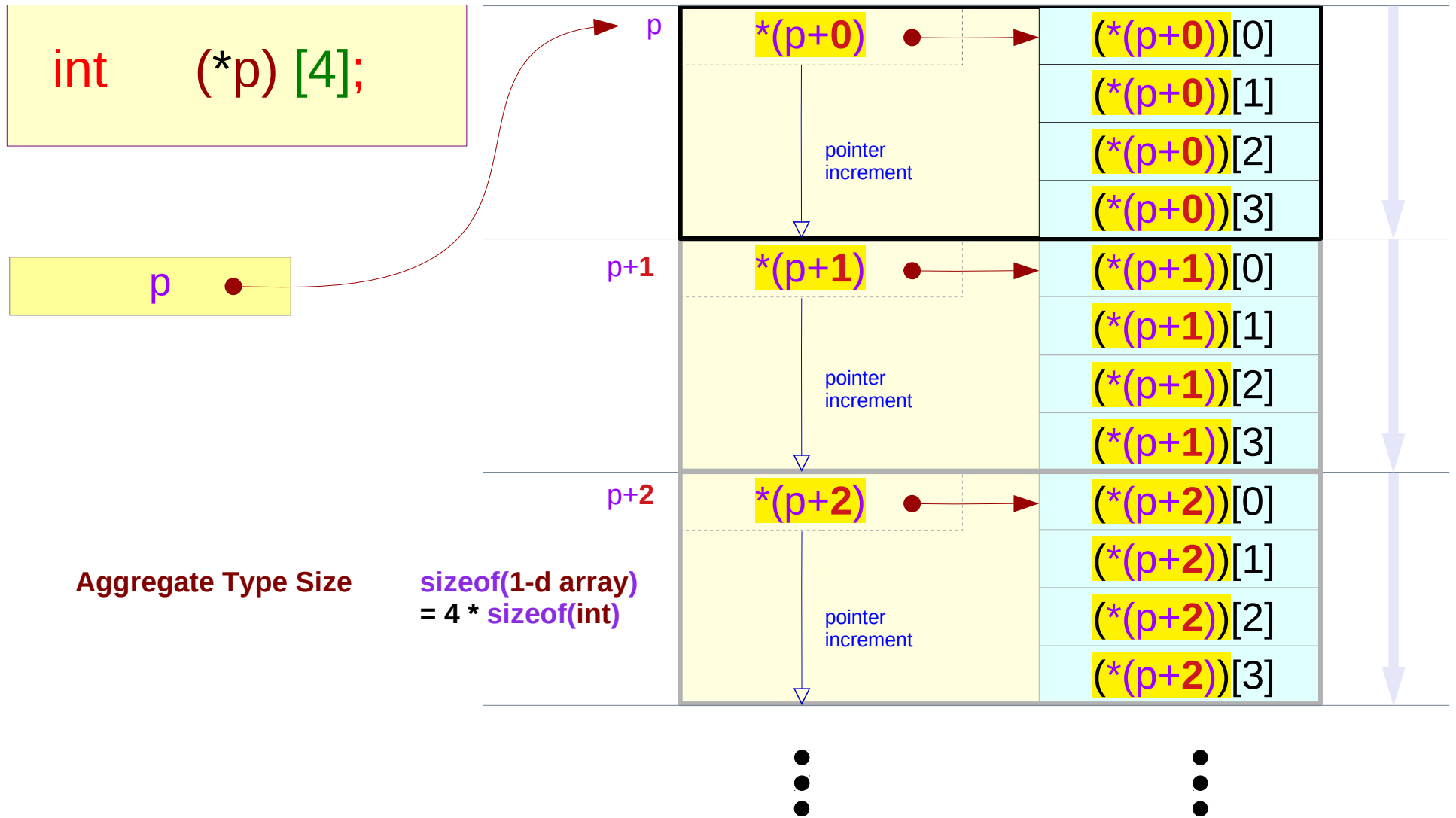

2-d array access using a 1-d array pointer

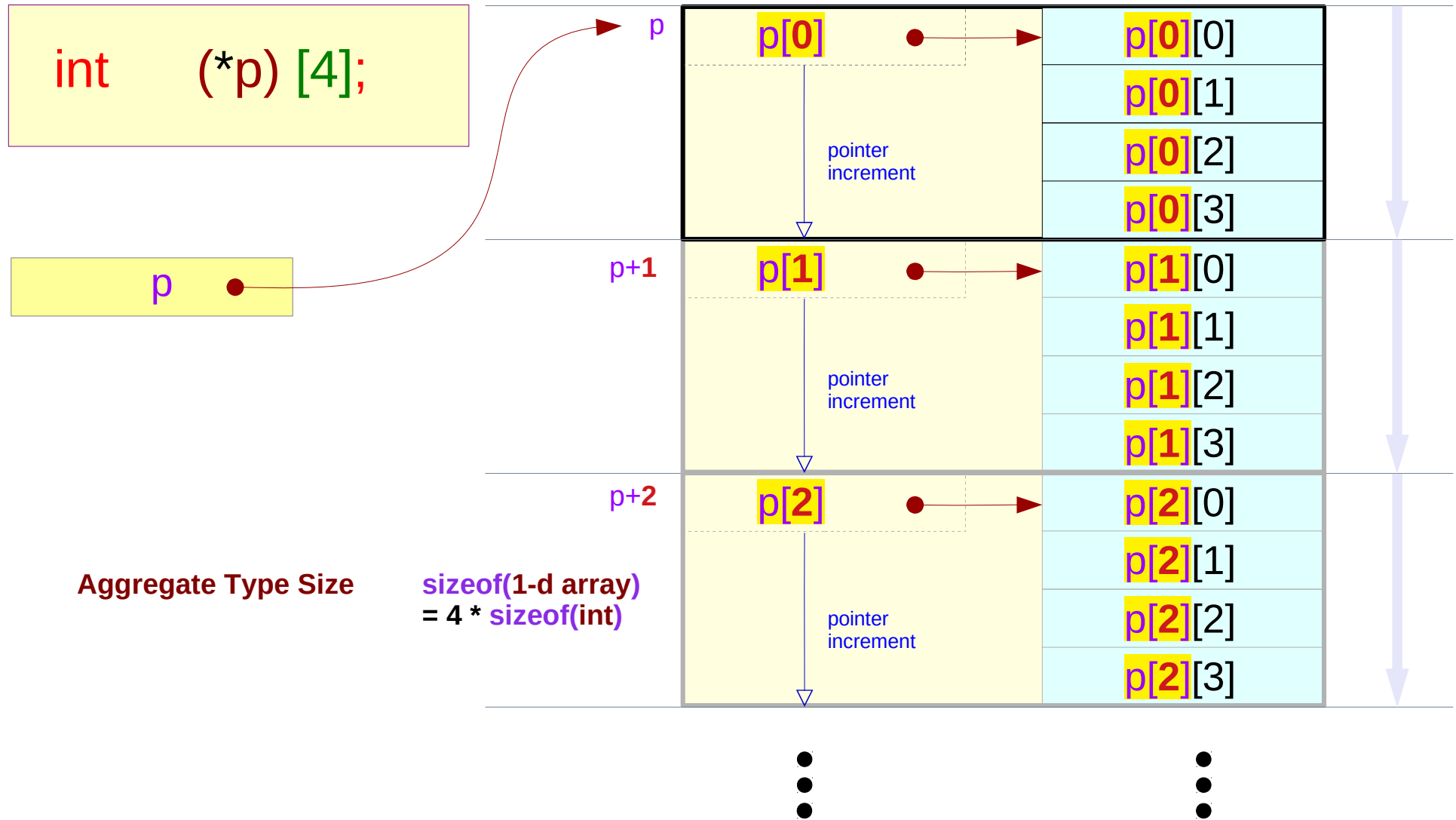

2-d array access using double pointers q

```
int c [3] [4];
```

```
int **p, *q[4];
```

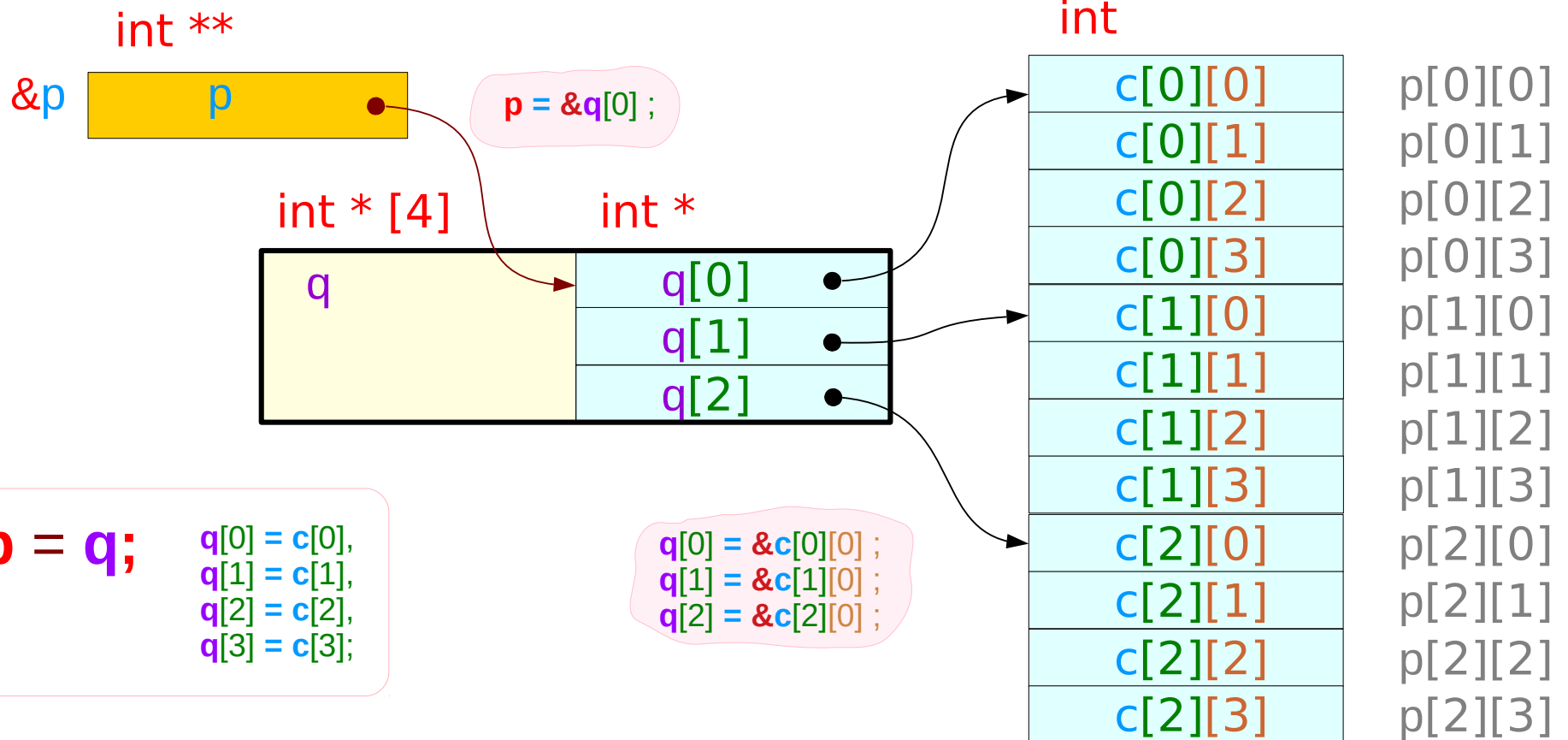

References

- [1] Essential C, Nick Parlante
- [2] Efficient C Programming, Mark A. Weiss
- [3] C A Reference Manual, Samuel P. Harbison & Guy L. Steele Jr.
- [4] C Language Express, I. K. Chun