

CMOS Delay-7 (H.7) Elmore Delay

20170109

Copyright (c) 2015 - 2016 Young W. Lim.

Permission is granted to copy, distribute and/or modify this document under the terms of the GNU Free Documentation License, Version 1.2 or any later version published by the Free Software Foundation; with no Invariant Sections, no Front-Cover Texts, and no Back-Cover Texts. A copy of the license is included in the section entitled "GNU Free Documentation License".

References

Some Figures from the following sites

[1] <http://pages.hmc.edu/harris/cmosvlsi/4e/index.html>
Weste & Harris Book Site

[2] en.wikipedia.org

RC Delay Model

- ❑ Use equivalent circuits for MOS transistors
 - Ideal switch + capacitance and ON resistance
 - Unit nMOS has resistance R , capacitance C
 - Unit pMOS has resistance $2R$, capacitance C
- ❑ Capacitance proportional to width
- ❑ Resistance inversely proportional to width

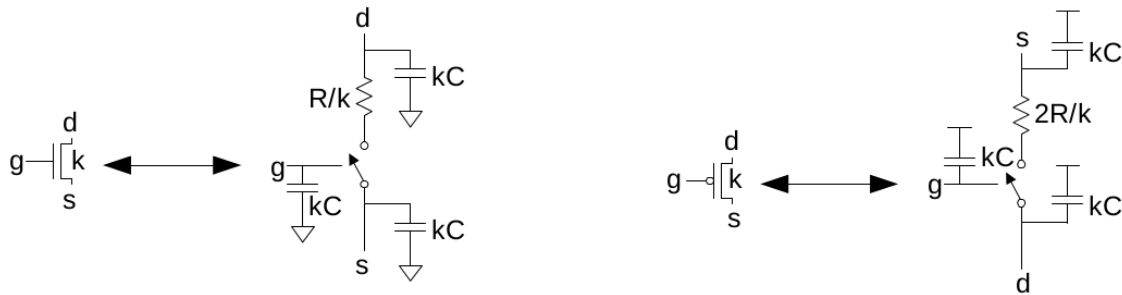

Elmore Delay

- ❑ ON transistors look like resistors
- ❑ Pullup or pulldown network modeled as *RC ladder*
- ❑ Elmore delay of RC ladder

$$t_{pd} \approx \sum_{\text{nodes } i} R_{i\text{-to-source}} C_i$$

$$= R_1 C_1 + (R_1 + R_2) C_2 + \dots + (R_1 + R_2 + \dots + R_N) C_N$$

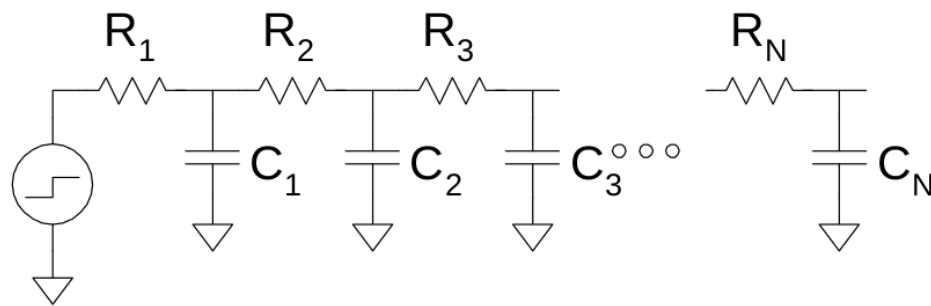

Step Response & Impulse Response

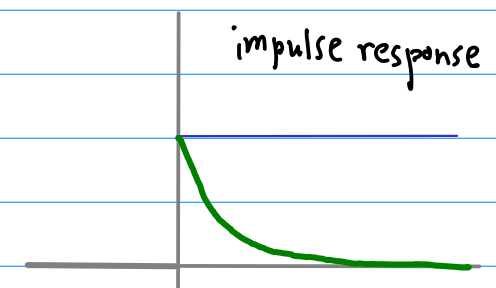
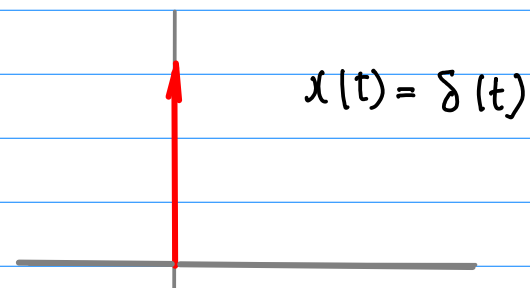
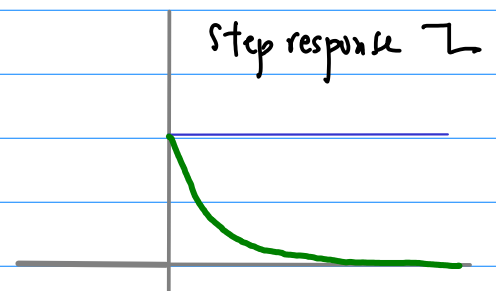
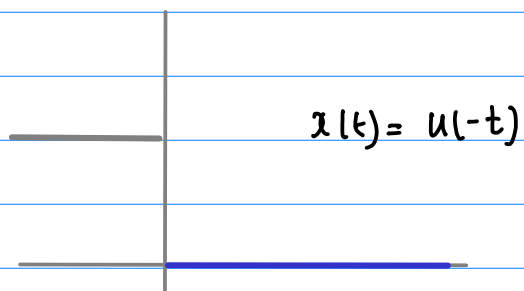
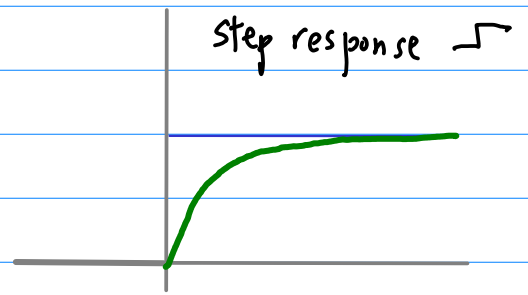
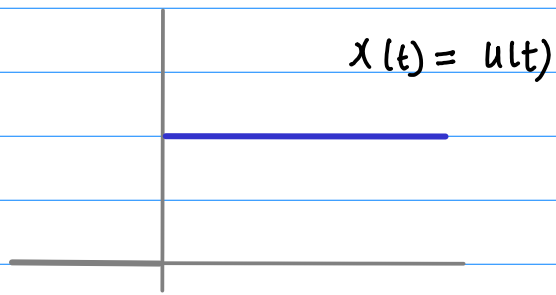

Transient Response : 1st Order RC Systems

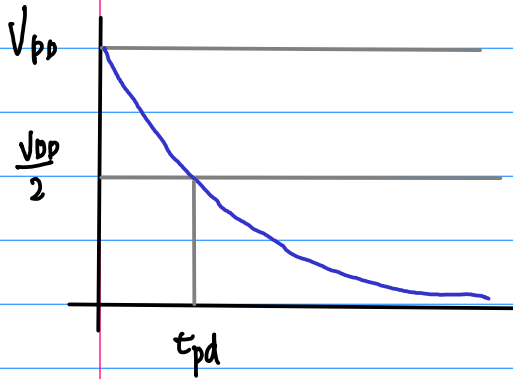
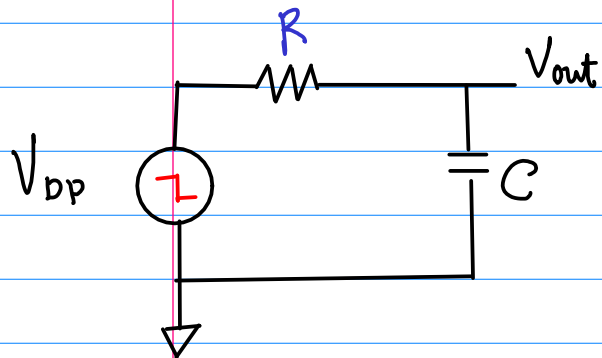

Step response to \downarrow

$$\frac{\frac{1}{sC}}{R + \frac{1}{sC}} = \frac{1}{1 + sRC}$$

$$H(s) = \frac{1}{1 + sRC}$$

$$V_{out}(t) = V_{DD} e^{-t/\tau}$$

$$\tau = RC$$

$$\frac{V_{DD}}{2} = V_{DD} e^{-t/\tau}$$

$$\frac{1}{2} = e^{-t/\tau}$$

$$-t/\tau = \ln 2^{-1}$$

$$t = \ln 2 \tau$$

$$t_{pd} = RC \ln 2$$

$$= R \ln 2 \cdot C$$

$$= R' C$$

Transient Response : 2nd Order RC Systems

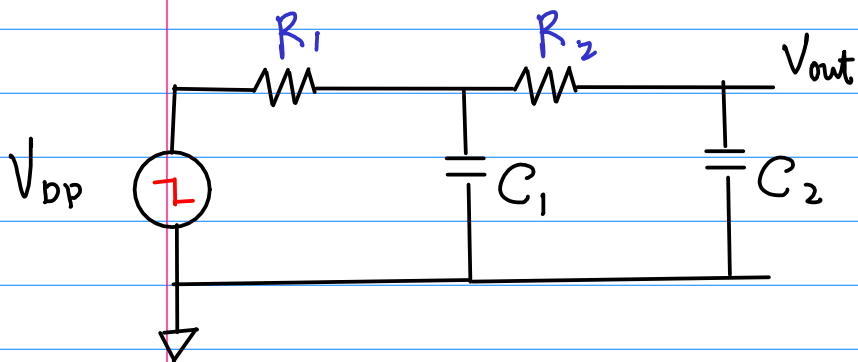

~~*~~

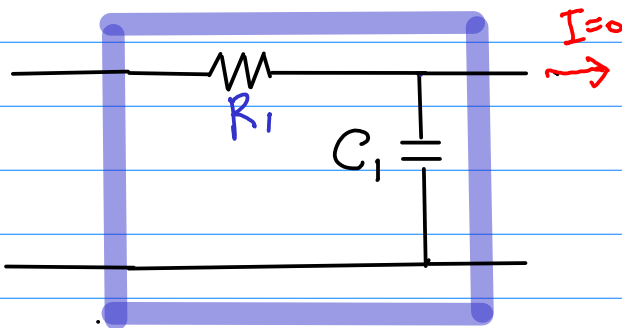

$$H(s) = \frac{1}{1 + sRC}$$

no current flow

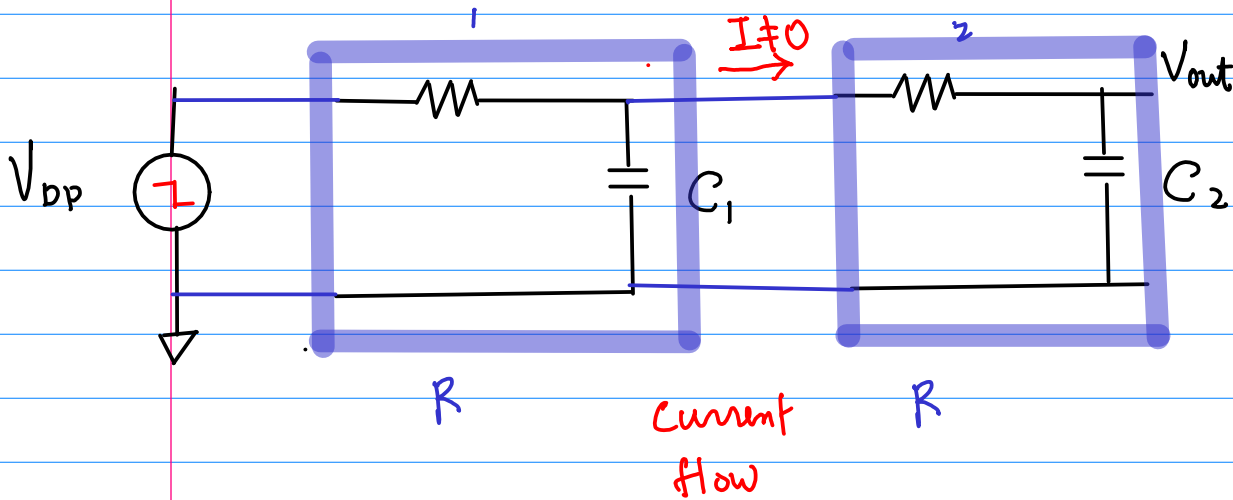

$$H(s) = \cancel{\frac{1}{1 + sR_1C_1}} \cdot \frac{1}{1 + sR_2C_2} = \frac{1}{1 + s(R_1C_1 + R_2C_2) + s^2R_1R_2C_1C_2}$$

Voltage Divider

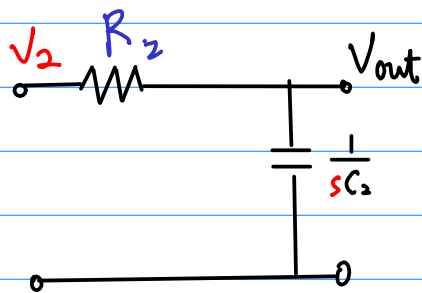
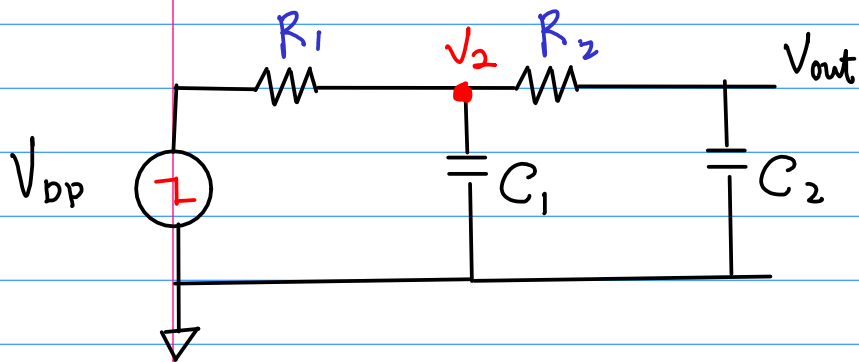

$$V_{out} = \frac{\frac{1}{sC_2}}{R_2 + \frac{1}{sC_2}} V_2$$

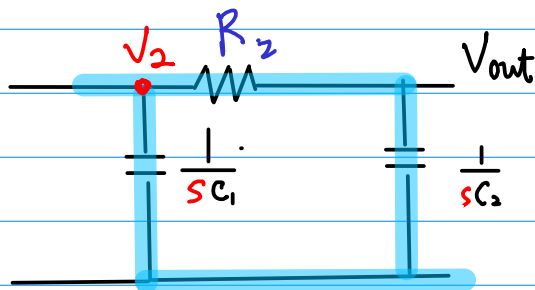

$$\frac{1}{sC_1} \parallel \left(R_2 + \frac{1}{sC_2} \right)$$

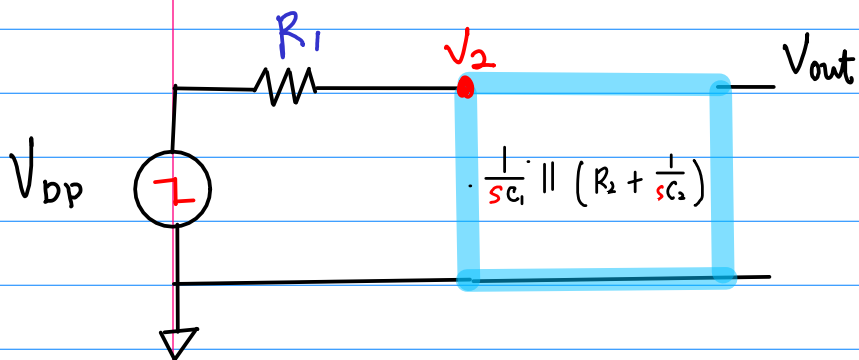

$$V_2 = \frac{\frac{1}{sC_1} \parallel \left(R_2 + \frac{1}{sC_2} \right)}{R_1 + \frac{1}{sC_1} \parallel \left(R_2 + \frac{1}{sC_2} \right)} V_{dp}$$

→
$$V_{out} = \frac{1}{1 + sR_2C_2} V_2$$

Transfer Function $H(s)$

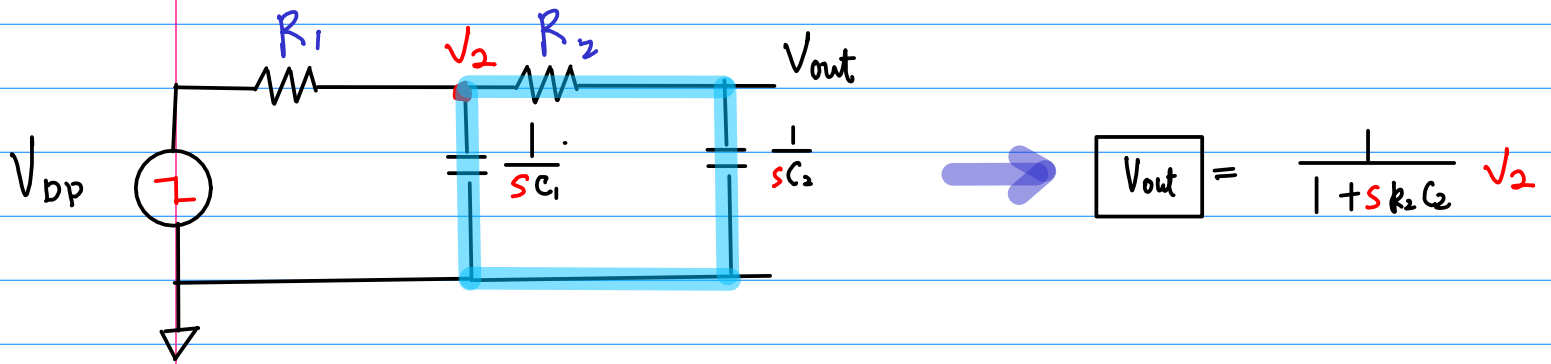

$$V_{out} = \frac{1}{1 + sR_2C_2} V_2$$

$$\frac{1}{sC_1} \parallel \left(R_2 + \frac{1}{sC_2} \right) = \frac{1}{sC_1 + \frac{1}{R_2 + \frac{1}{sC_2}}} = \frac{1}{sC_1 + \frac{sC_2}{sR_2C_2 + 1}}$$

$$= \frac{sR_2C_2 + 1}{s^2R_2C_1C_2 + sC_1 + sC_2} = \frac{sR_2C_2 + 1}{s^2R_2C_1C_2 + s(C_1 + C_2)}$$

$$V_2 = \frac{\frac{sR_2C_2 + 1}{s^2R_2C_1C_2 + s(C_1 + C_2)} V_{dp}}{R_1 + \frac{sR_2C_2 + 1}{s^2R_2C_1C_2 + s(C_1 + C_2)}} \quad V_{dp} = \frac{sR_2C_2 + 1}{s^2R_1R_2C_1C_2 + s(R_1C_1 + R_1C_2 + R_2C_2) + 1} V_{dp}$$

$$V_{out} = \frac{1}{1 + sR_2C_2} V_2 = \frac{1}{\cancel{(1 + sR_2C_2)} s^2R_1R_2C_1C_2 + s(R_1C_1 + R_1C_2 + R_2C_2) + 1} V_{dp}$$

$$H(s) = \frac{1}{1 + s[R_1C_1 + (R_1 + R_2)C_2] + s^2R_1C_1R_2C_2}$$

Quadratic Equations

the reciprocals of the roots

$$a s^2 + b s + c = 0$$

$$s = \frac{-b \pm \sqrt{b^2 - 4ac}}{2a}$$

$$\frac{1}{s} = \frac{2a}{-b \pm \sqrt{b^2 - 4ac}} \rightarrow \frac{1}{2c} \left[-b \mp \sqrt{b^2 - 4ac} \right]$$

$$\frac{1}{-b \pm \sqrt{b^2 - 4ac}} = \frac{-b \mp \sqrt{b^2 - 4ac}}{(-b)^2 - (b^2 - 4ac)} = \frac{-b \mp \sqrt{b^2 - 4ac}}{4ac}$$

$$\frac{2a}{-b \pm \sqrt{b^2 - 4ac}} = 2a \cdot \frac{-b \mp \sqrt{b^2 - 4ac}}{4ac} = \frac{1}{2c} \left[-b \mp \sqrt{b^2 - 4ac} \right]$$

the reciprocals of the poles of $H(s)$

$$a s^2 + b s + c = 0$$

$$\frac{1}{s} = \frac{2a}{-b \pm \sqrt{b^2 - 4ac}} \rightarrow \frac{1}{2c} \left[-b \mp \sqrt{b^2 - 4ac} \right]$$

$$1 + s \left[R_1 C_1 + (R_1 + R_2) C_2 \right] + s^2 R_1 C_1 R_2 C_2 = (1 + s z_1) (1 + s z_2) = 0$$

$$s = -\frac{1}{z_1}, -\frac{1}{z_2} \quad \frac{1}{s} = z_1, z_2$$

$$a = R_1 C_1 R_2 C_2$$

$$b = \left[R_1 C_1 + (R_1 + R_2) C_2 \right]$$

$$c = 1$$

$$\frac{1}{s} = \frac{1}{2c} \left[-b \mp \sqrt{b^2 - 4ac} \right] \rightarrow$$

$$\frac{1}{s} = \frac{1}{2} \left[-\left[R_1 C_1 + (R_1 + R_2) C_2 \right] \mp \sqrt{\left[R_1 C_1 + (R_1 + R_2) C_2 \right]^2 - 4 R_1 C_1 R_2 C_2} \right]$$

$$\frac{1}{s} = -\frac{1}{2} \left[R_1 C_1 + (R_1 + R_2) C_2 \right] \left[1 \pm \sqrt{1 - \frac{4 R_1 C_1 R_2 C_2}{\left[R_1 C_1 + (R_1 + R_2) C_2 \right]^2}} \right]$$

Time constants τ_1 & τ_2

$$1 + s[R_1 C_1 + (R_1 + R_2) C_2] + s^2 R_1 C_1 R_2 C_2 = (1 + s \tau_1)(1 + s \tau_2) = 0$$

$$s = -\frac{1}{\tau_1}, -\frac{1}{\tau_2}$$

$$\frac{1}{s} = -\frac{1}{2} [R_1 C_1 + (R_1 + R_2) C_2] \left[1 \pm \sqrt{1 - \frac{4 R_1 C_1 R_2 C_2}{[R_1 C_1 + (R_1 + R_2) C_2]^2}} \right]$$

$$\frac{R_2}{R_1} \equiv R'$$

$$\frac{C_2}{C_1} \equiv C'$$

$$\sqrt{1 - \frac{4 R_1 C_1 R_2 C_2}{[R_1 C_1 + (R_1 + R_2) C_2]^2}}$$

$$\equiv \sqrt{1 - \frac{4 \frac{R_2}{R_1} \frac{C_2}{C_1}}{\left[1 + \left(1 + \frac{R_2}{R_1} \right) \frac{C_2}{C_1} \right]^2}}$$

$$\equiv \sqrt{1 - \frac{4 R' C'}{\left[1 + (1 + R') C' \right]^2}}$$

$$\tau_1, \tau_2 = \frac{1}{2} [R_1 C_1 + (R_1 + R_2) C_2] \left[1 \pm \sqrt{1 - \frac{4 R' C'}{\left[1 + (1 + R') C' \right]^2}} \right]$$

Unit Step Response

$$H(s) = \frac{1}{1 + s[R_1 C_1 + (R_1 + R_2)C_2] + s^2 R_1 C_1 R_2 C_2}$$
$$= \frac{1}{(1 + s z_1)(1 + s z_2)} = \left[\frac{A}{(1 + s z_1)} + \frac{B}{(1 + s z_2)} \right]$$

$$A = \frac{1}{(1 + s z_2)} \Big|_{s = -\frac{1}{z_1}} = \frac{1}{(1 - \frac{z_2}{z_1})} = \frac{z_1}{z_1 - z_2}$$
$$B = \frac{1}{(1 + s z_1)} \Big|_{s = -\frac{1}{z_2}} = \frac{1}{(1 - \frac{z_1}{z_2})} = \frac{z_2}{z_2 - z_1}$$

$$H(s) = \frac{1}{z_1 - z_2} \left[\frac{z_1}{(1 + s z_1)} - \frac{z_2}{(1 + s z_2)} \right]$$

$$h(t) = \frac{1}{z_1 - z_2} \left[z_1 e^{-t/z_1} - z_2 e^{-t/z_2} \right]$$

step response to \downarrow

$$V_{out}(t) = \frac{1}{z_1 - z_2} \left[z_1 e^{-t/z_1} - z_2 e^{-t/z_2} \right] V_{DD}$$

$$\tau_1, \tau_2 = \frac{1}{2} [R_1 C_1 + (R_1 + R_2) C_2] \left[1 \pm \sqrt{1 - \frac{4 R' C'}{[1 + (1 + R') C']^2}} \right]$$

$$\tau = \tau_1 + \tau_2 = [R_1 C_1 + (R_1 + R_2) C_2]$$

$$R = R_1 = R_2$$

$$C = C_1 = C_2$$

$$\tau_1 = 2.6 RC$$

$$\tau_2 = 0.4 RC$$

$$\tau = 3.0 RC$$

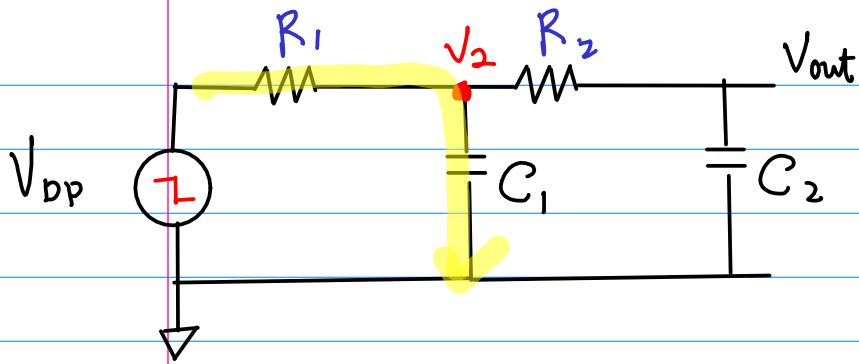

$$Z_1 = R_1 C_1$$

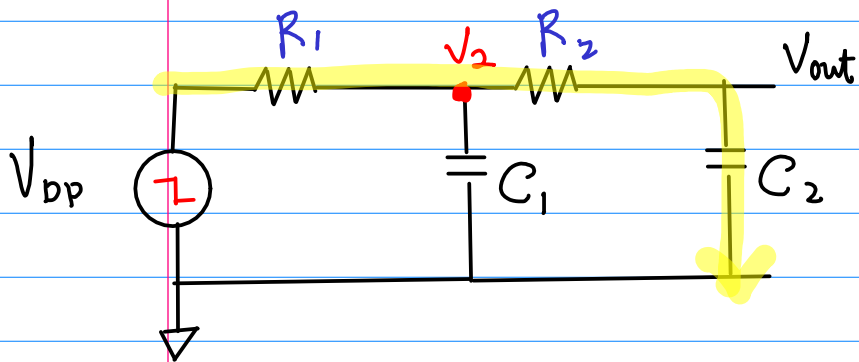

$$Z_2 = (R_1 + R_2) C_2$$

$$Z = Z_1 + Z_2 = [R_1 C_1 + (R_1 + R_2) C_2]$$

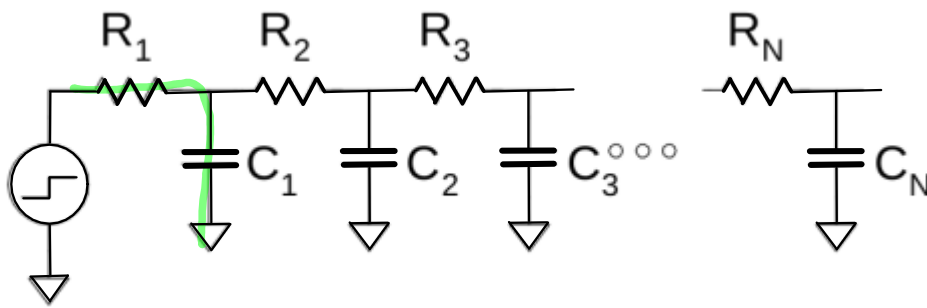

$$R_1 C_1$$

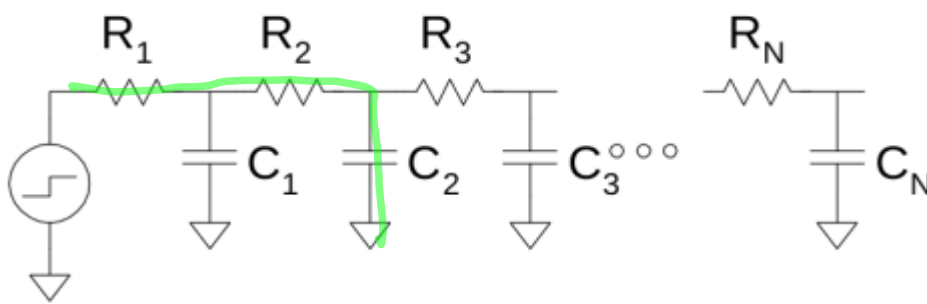

$$(R_1 + R_2) C_2$$

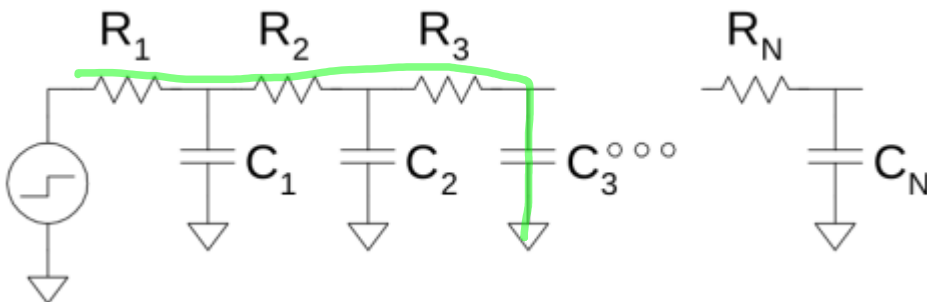

$$(R_1 + R_2 + R_3) C_3$$

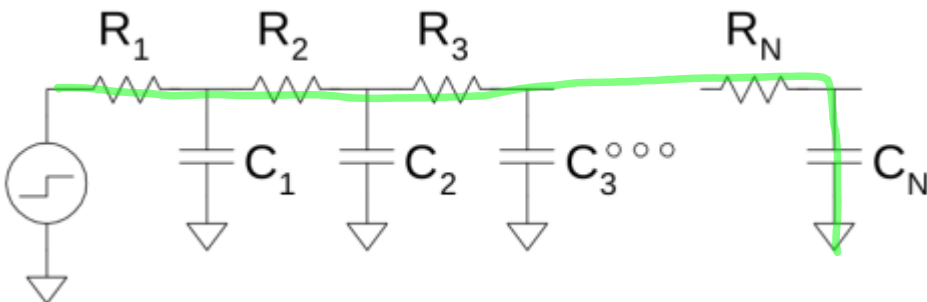

$$(R_1 + R_2 + \dots + R_N) C_N$$

$$t_{pd} = R_1 C_1 + (R_1 + R_2) C_2 + \dots + (R_1 + R_2 + \dots + R_N) C_N$$



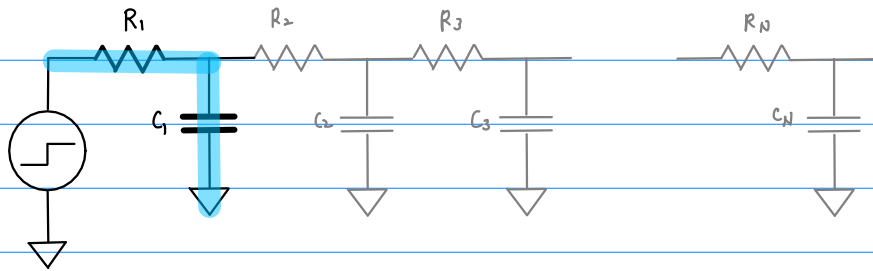

$$(R_1) C_i$$

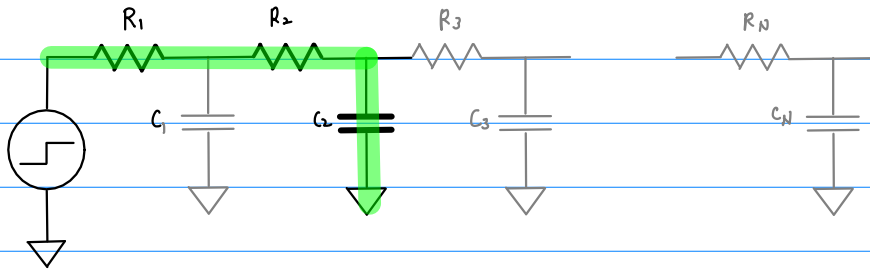

$$(R_1 + R_2) C_i$$

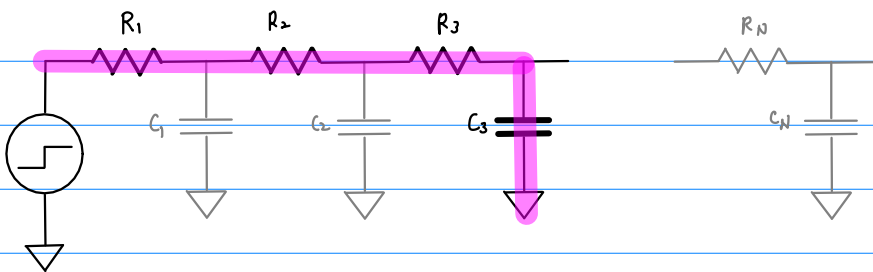

$$(R_1 + R_2 + R_3) C_i$$

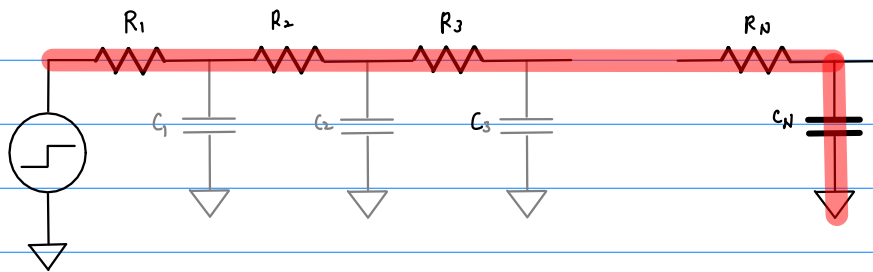

$$(R_1 + R_2 + \dots + R_N) C_i$$

$$\sum_{i=1}^n \left(\sum_{j=1}^i R_j \right) C_i$$

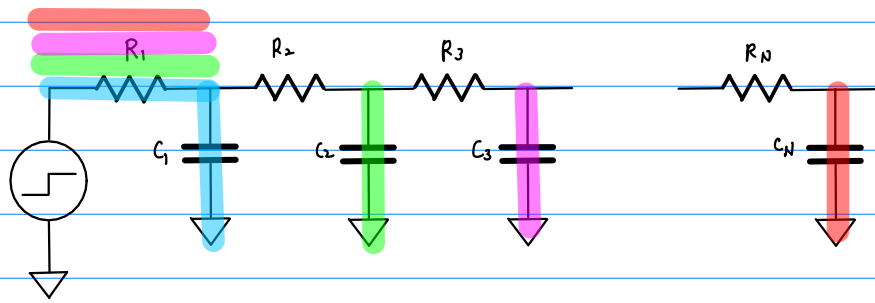

$$(C_1 + C_2 + \dots + C_N) R_1$$

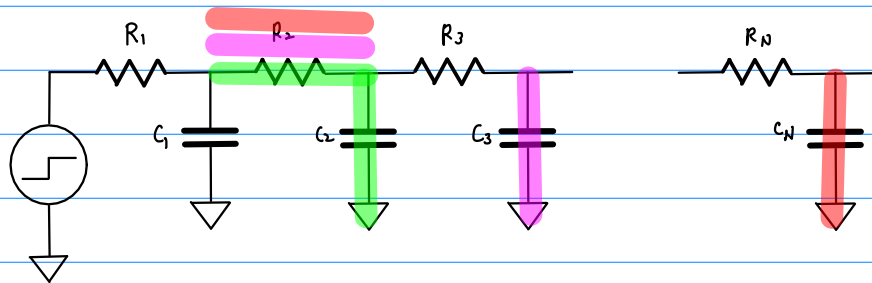

$$(C_2 + C_3 + \dots + C_N) R_2$$

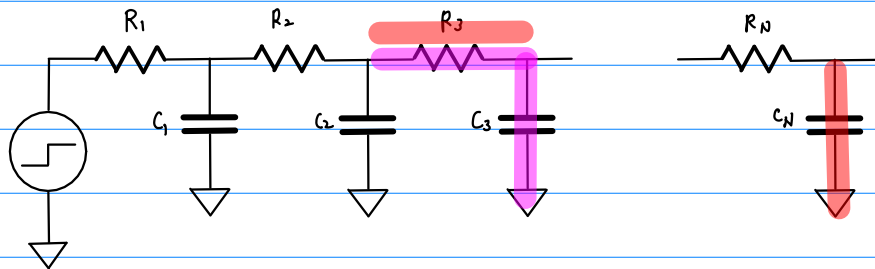

$$(C_3 + \dots + C_N) R_3$$

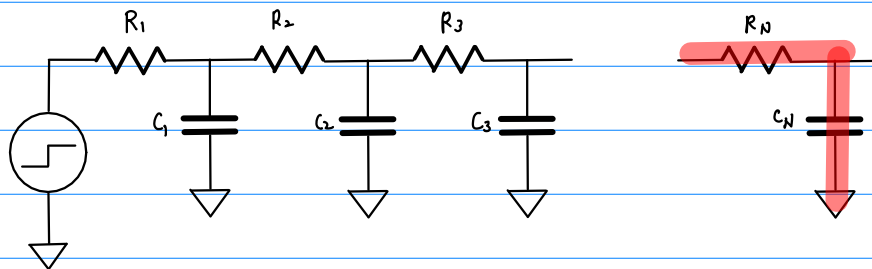

$$C_N R_N$$

$$\sum_{i=1}^n \left(\sum_{j=i}^n C_j \right) R_i$$

