

Pipelined Architecture (2A)

Copyright (c) 2014 - 2018 Young W. Lim.

Permission is granted to copy, distribute and/or modify this document under the terms of the GNU Free Documentation License, Version 1.2 or any later version published by the Free Software Foundation; with no Invariant Sections, no Front-Cover Texts, and no Back-Cover Texts. A copy of the license is included in the section entitled "GNU Free Documentation License".

Please send corrections (or suggestions) to youngwlim@hotmail.com.

This document was produced by using LibreOffice.

Based on

ARM System-on-Chip Architecture, 2nd ed, Steve Furber

3-stage Pipeline

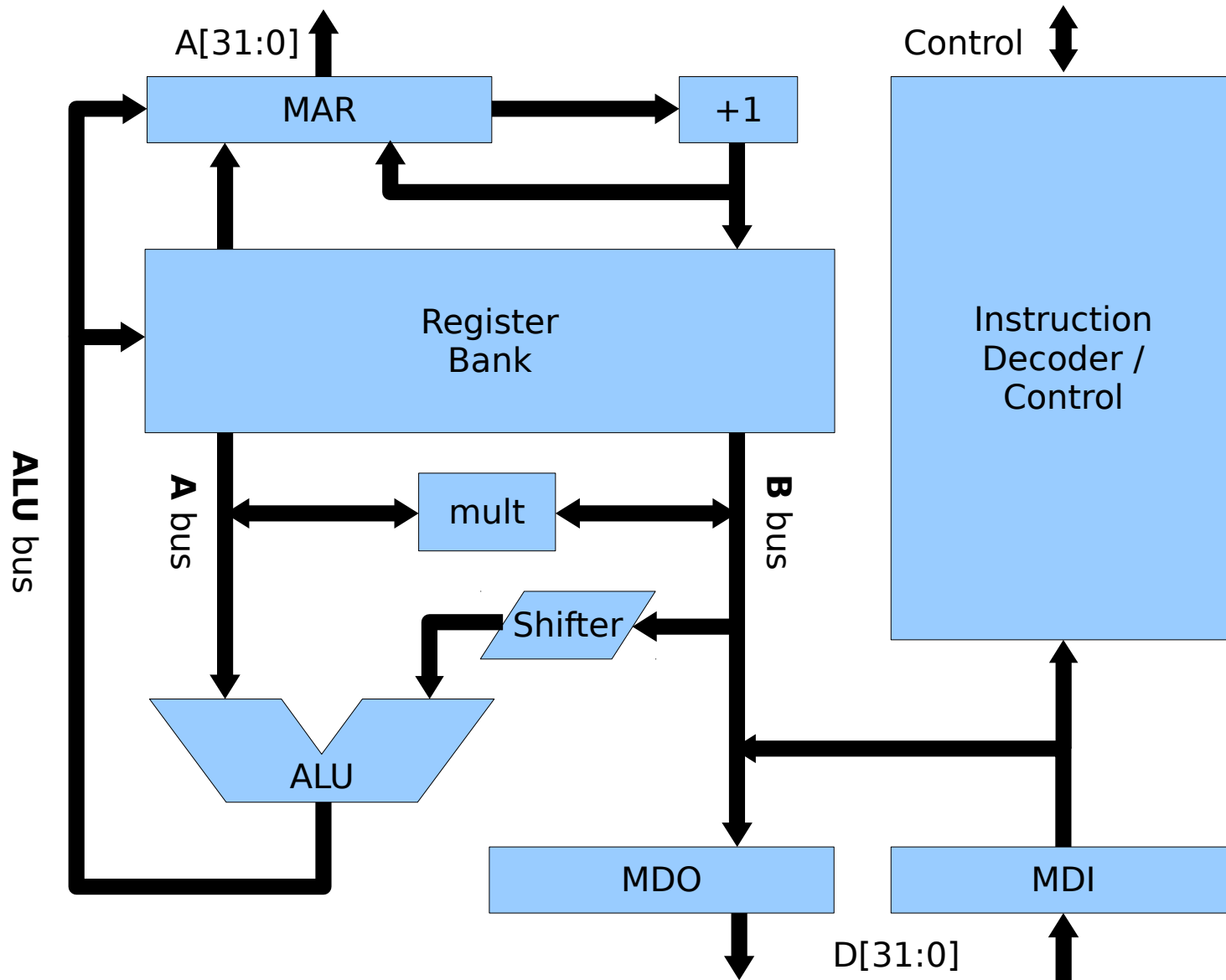

Register-Register Operations

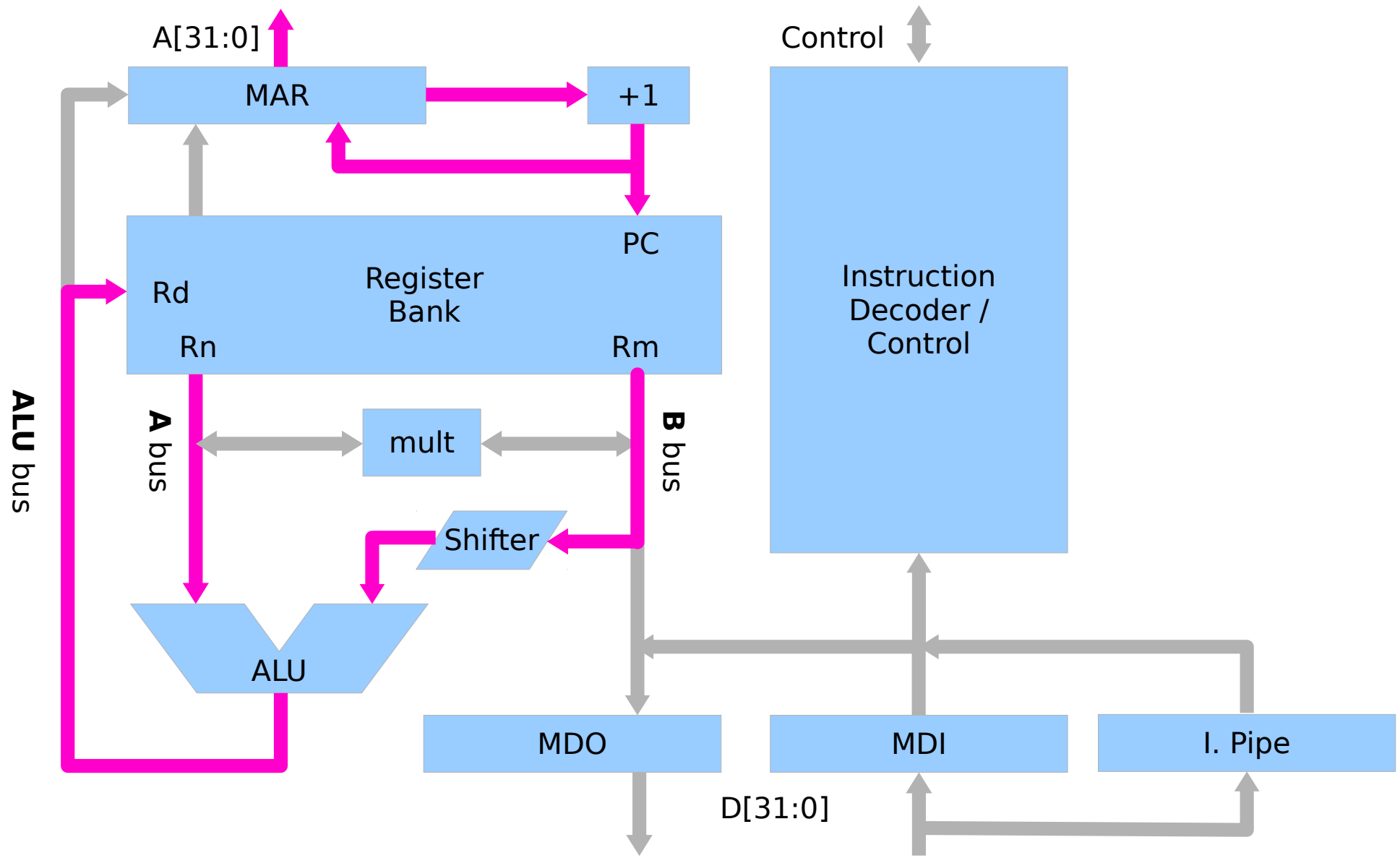

Register-Immediate Operations

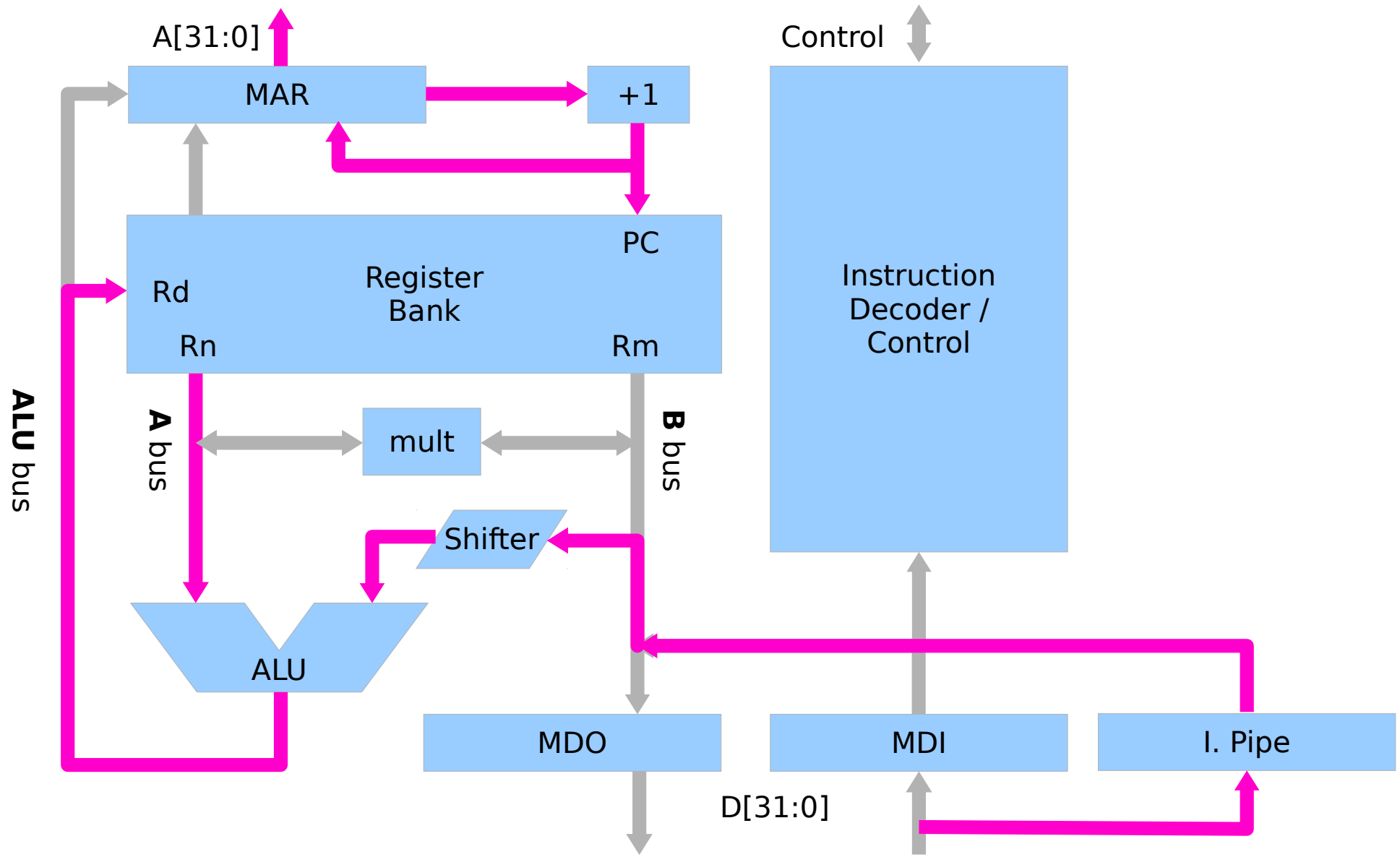

STR - 1st Cycle

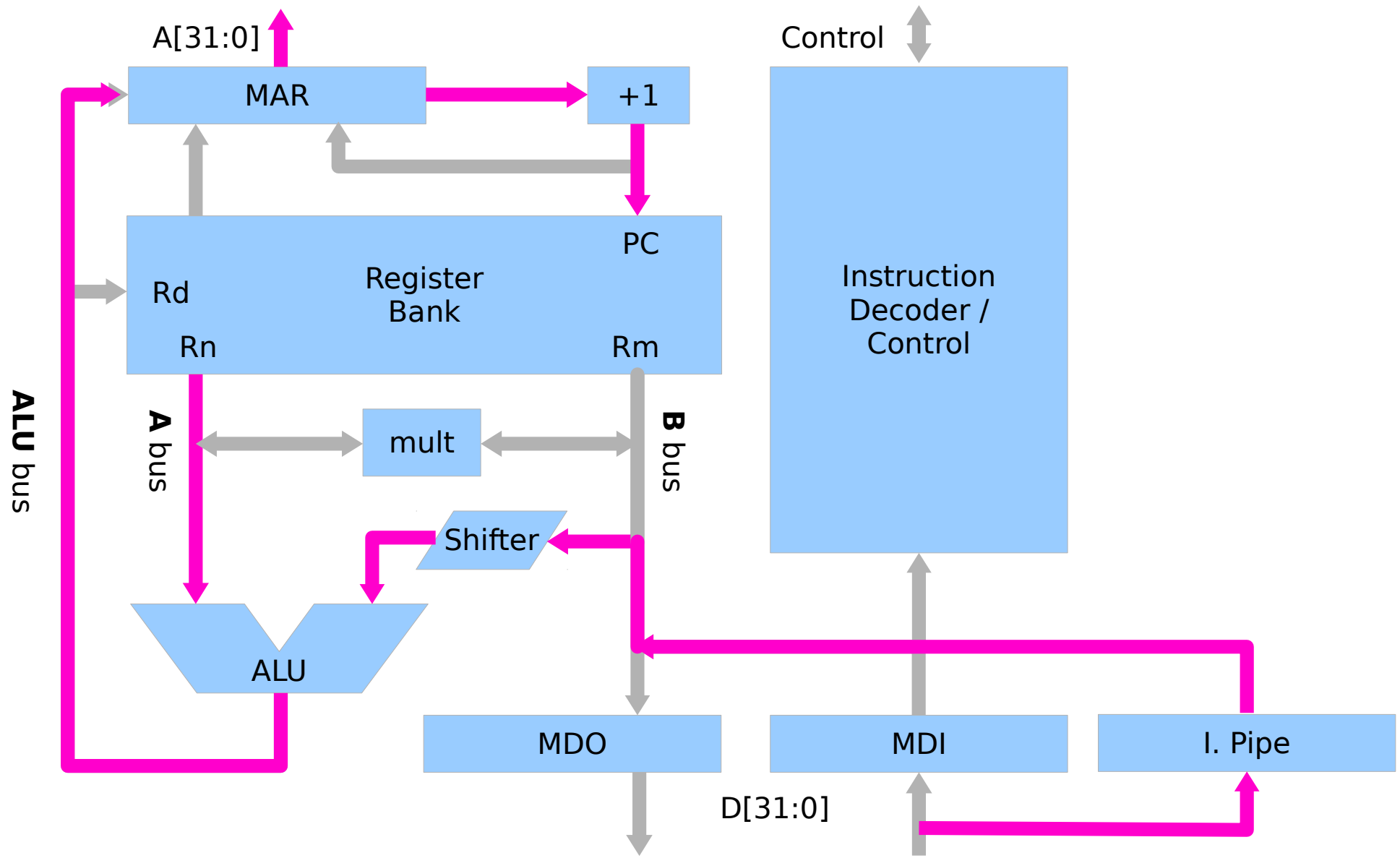

STR - 2nd Cycle

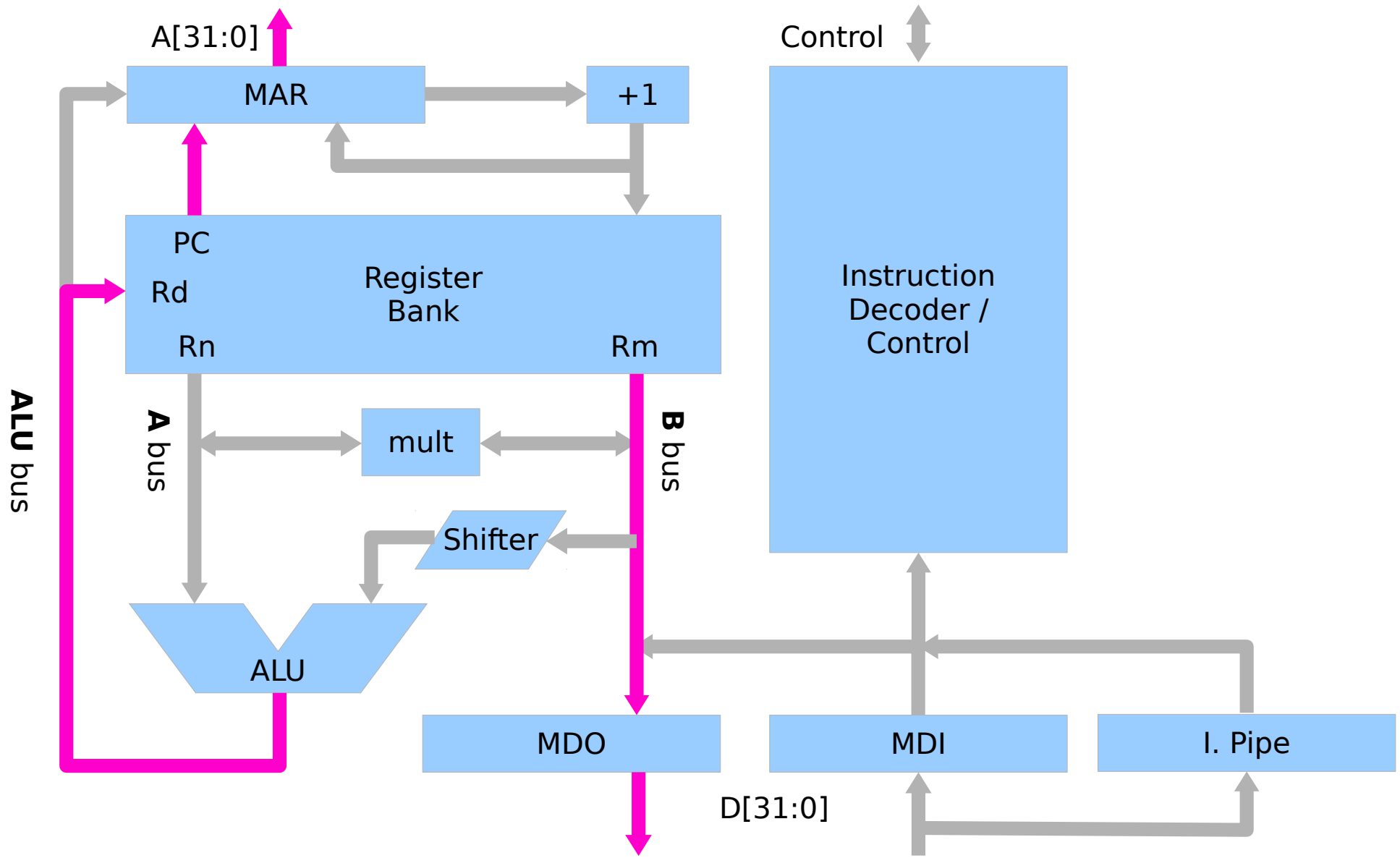

B - 1st Cycle

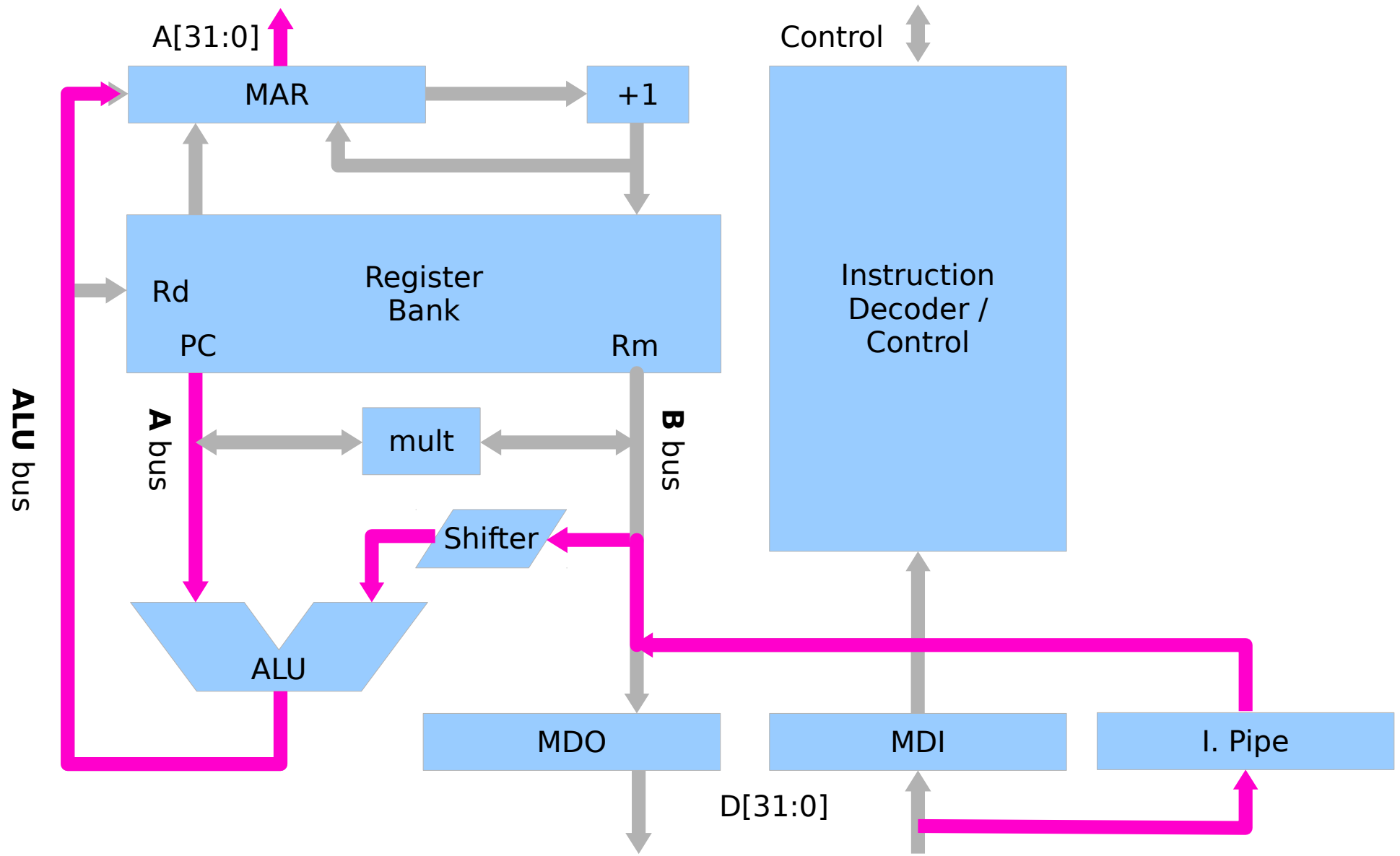

B - 2nd Cycle

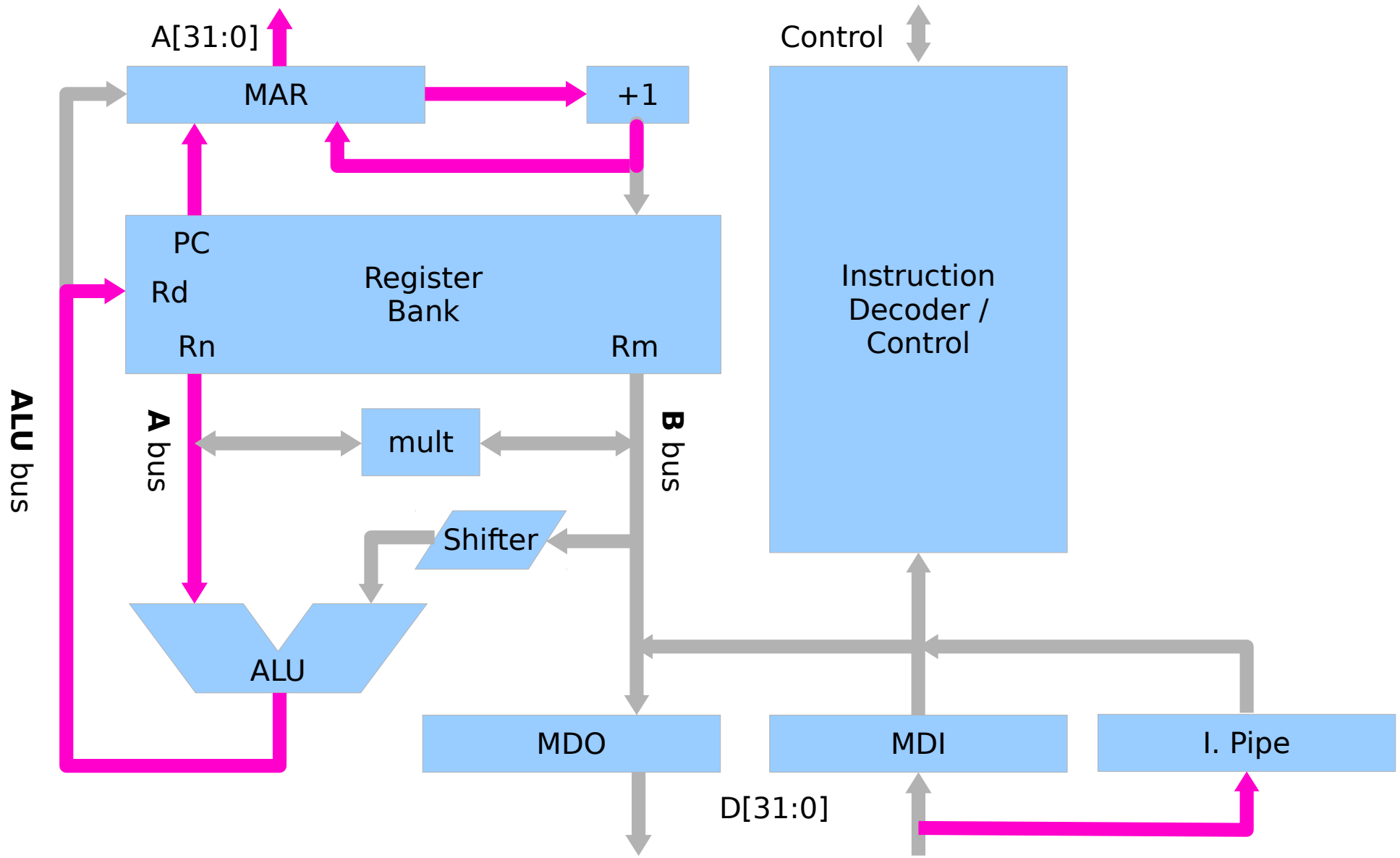

ARM Instruction Set

The load-store architecture

3-address data processing instructions

(2 source registers + 1 destination register)

Conditionally executes every instruction

Multiple data transfer instruction

Single cycle execution of shift and ALU operations

Open instruction set for coprocessors

A very dense 16-bit compressed instruction set (Thumb)

ARM Exception Handling

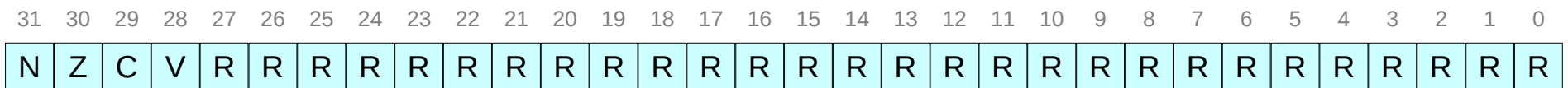

References

- [1] <ftp://ftp.geoinfo.tuwien.ac.at/navratil/HaskellTutorial.pdf>
- [2] <https://www.umiacs.umd.edu/~hal/docs/daume02yaht.pdf>