

Applications of Array Pointers (1A)

Copyright (c) 2010 - 2021 Young W. Lim.

Permission is granted to copy, distribute and/or modify this document under the terms of the GNU Free Documentation License, Version 1.2 or any later version published by the Free Software Foundation; with no Invariant Sections, no Front-Cover Texts, and no Back-Cover Texts. A copy of the license is included in the section entitled "GNU Free Documentation License".

Please send corrections (or suggestions) to youngwlim@hotmail.com.
This document was produced by using LibreOffice.

Virtual array pointers in a multi-dimensional array

Pointers to various data types

int *p; **int i, j, k;**



double *q; **double a, b, c;**

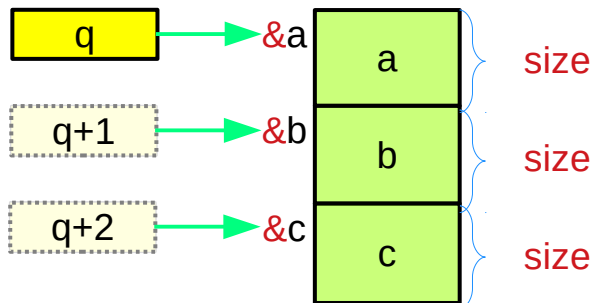

T *p; **T X, Y, Z;**

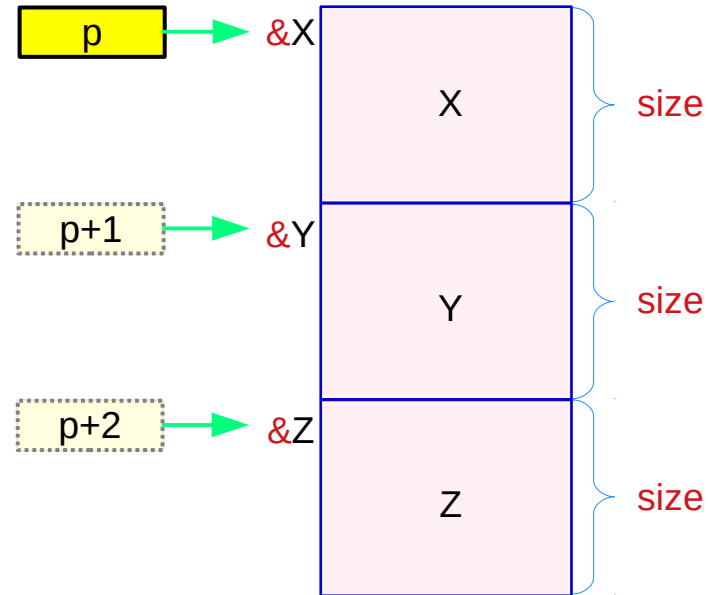

pointer

abstract data

Pointers to primitive data

int *p;

int i, j, k;

sizeof(int) = 4 bytes

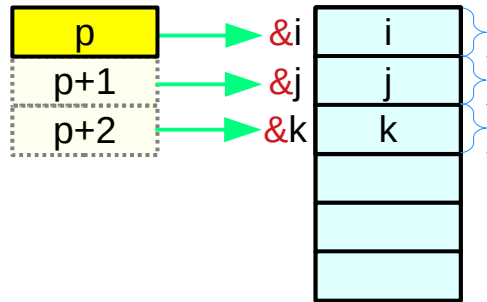

size
size
size

== sizeof(i) == sizeof(*p)
== sizeof(j) == sizeof(*(p+1))
== sizeof(k) == sizeof(*(p+2))

≠ sizeof(p)
≠ sizeof(p+1)
≠ sizeof(p+2)

pointer size
4 or 8 bytes

double *q;

double a, b, c;

sizeof(double) = 8 bytes

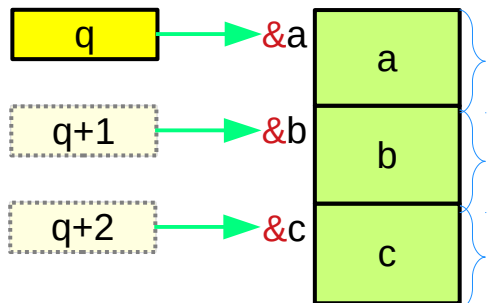

size
size
size

== sizeof(a) == sizeof(*q)
== sizeof(b) == sizeof(*(q+1))
== sizeof(c) == sizeof(*(q+2))

≠ sizeof(q)
≠ sizeof(q+1)
≠ sizeof(q+2)

pointer size
4 or 8 bytes

Pointers to abstract data

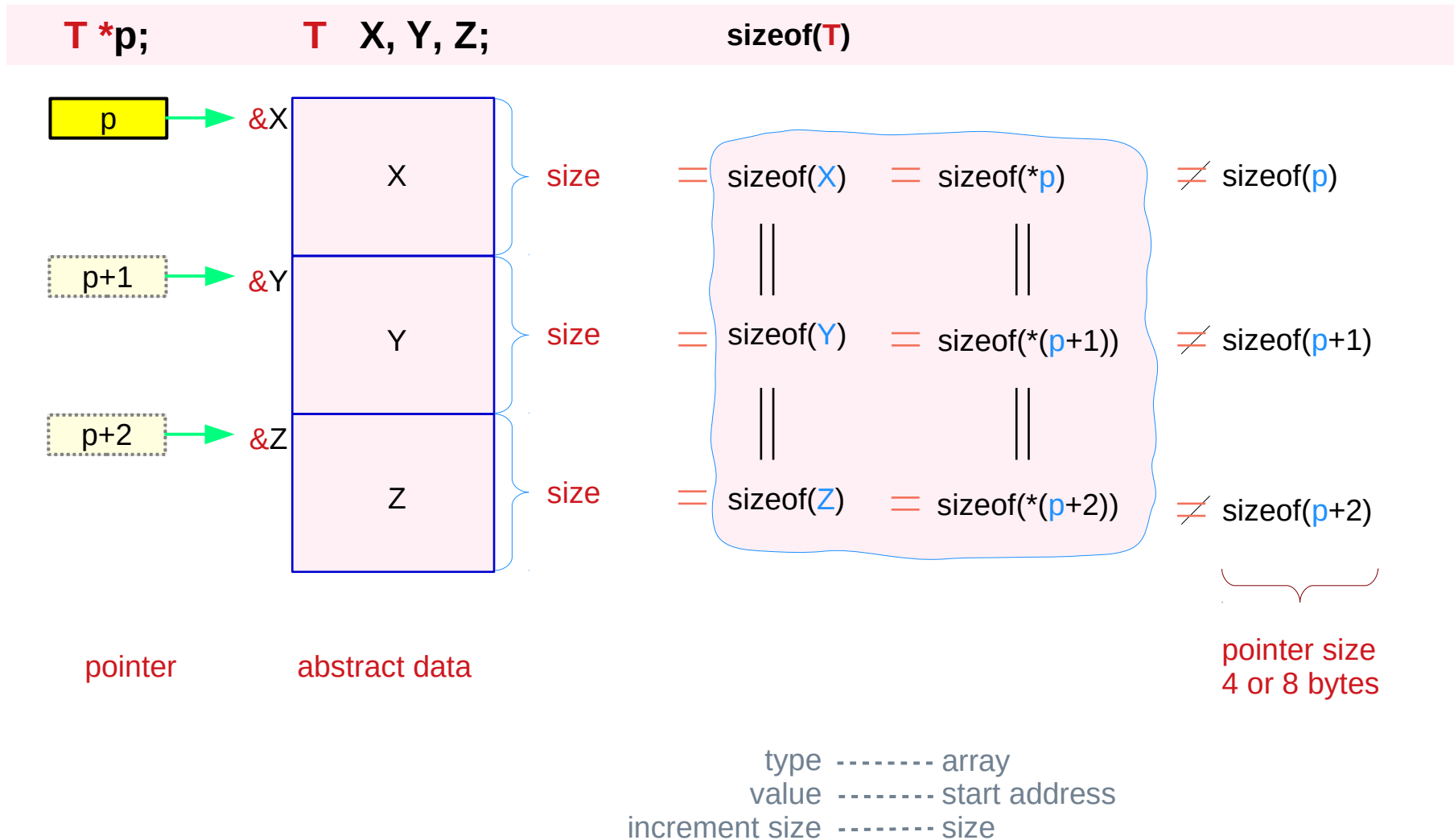

Array pointer types v.s. array types

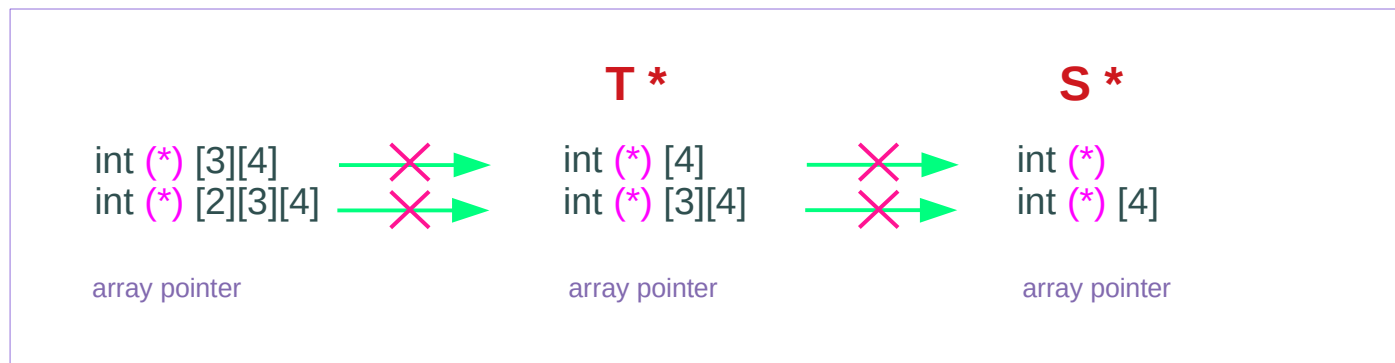
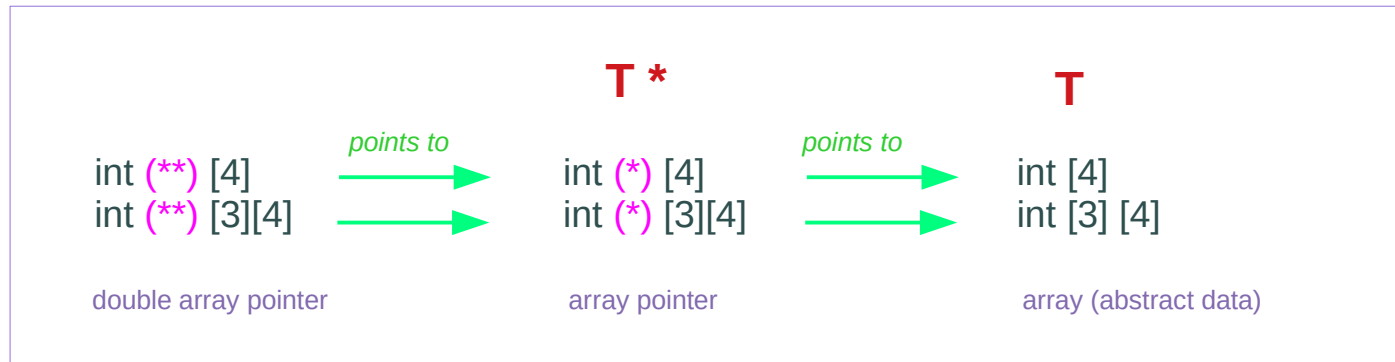

General array pointer types v.s. specific array types

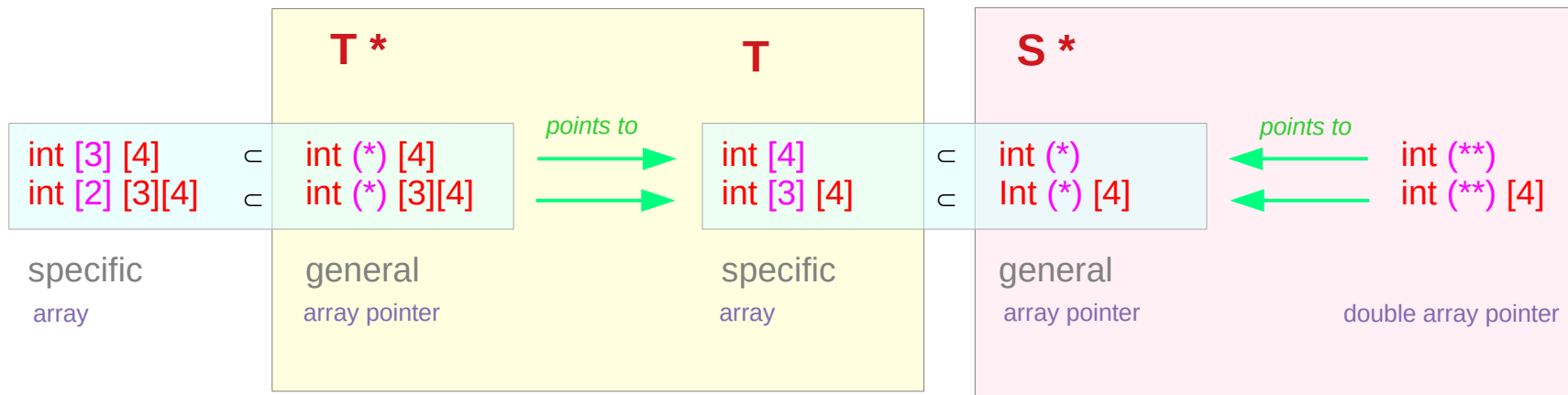

Array pointers have augmented dimensions

```
typedef int (*T1) [4];  
typedef int (*T1) [3][4];
```

int (*) [4]
int (*) [3][4]
general

```
typedef int T2[4];  
typedef int T2[3][4];
```

int [4]
int [3] [4]
specific

```
T1 a;  
T2 b;
```

T1 is a pointer type
T2 is an array type
T1 has one more dimension than T2

```
a = &b;  
*a = b;
```

a references b

b is the dereference of a

```
(a+1) = ?  
*(a+1) = ?
```

```
(a+2) = ?  
*(a+2) = ?
```

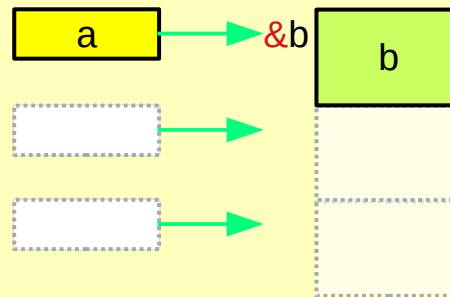

Dual types in an array of integers

```
int p[3];
```

p is an abstract data (array)

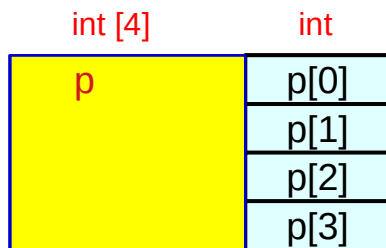

- p** is the name of an array
- p** has the size of the whole array
- p** has an array type (abstract data)

p can also be viewed as a pointer

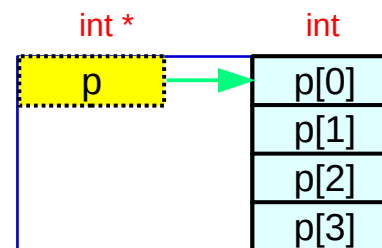

- p** also has pointer characteristics
- p** has the value of the starting address
- p** is a virtual pointer

Dual types in an array of abstract data

Abstract data array p

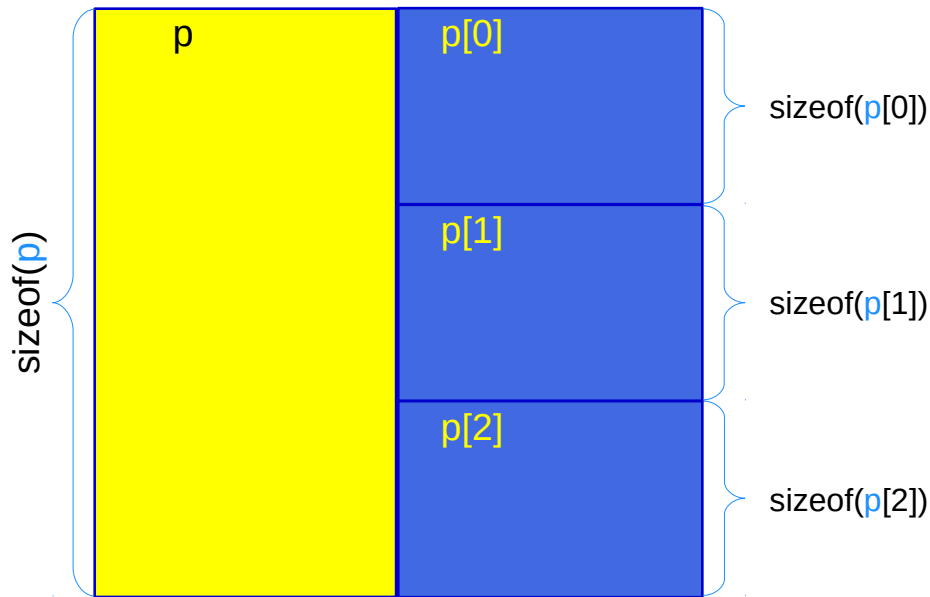

- p has an array type (abstract data element)
- p is the name of an array
- p has the size of the whole array

Virtual pointer p

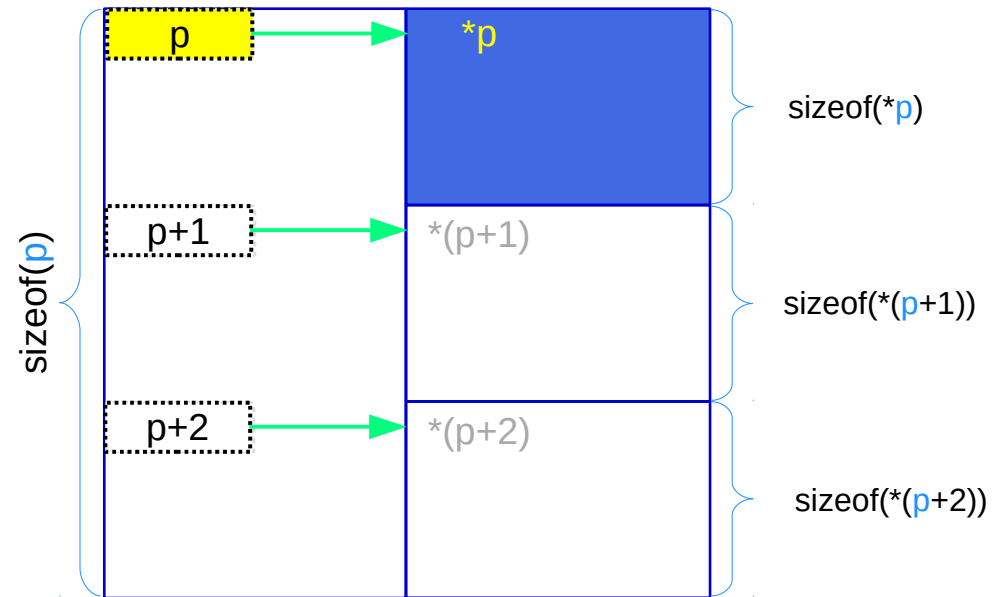

- p also has a pointer type
- p has the value of the starting address
- p is a virtual array pointer

Virtual pointer to abstract data

virtual pointer p abstract data *p

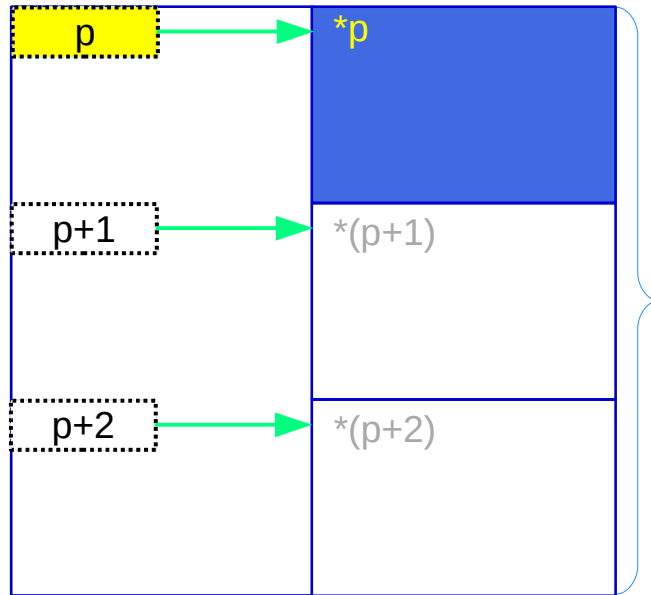

whole array size

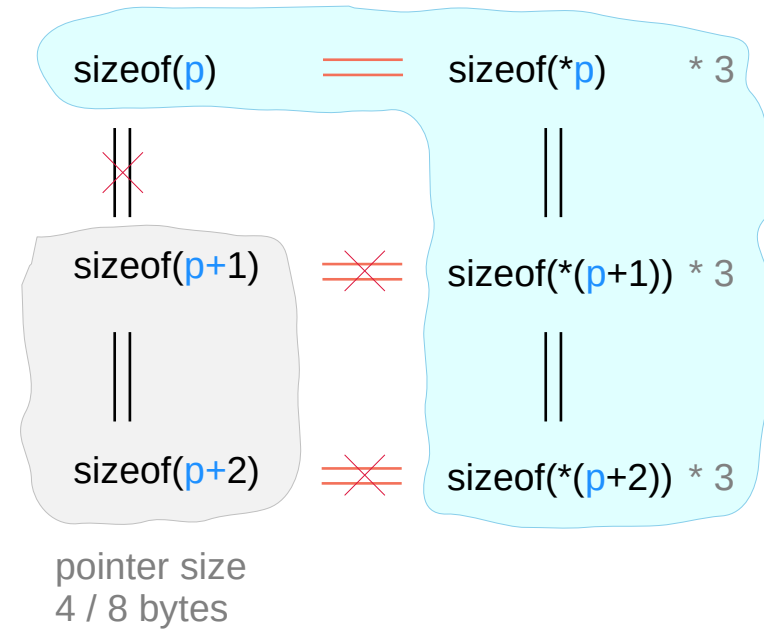

Dual types in a multi-dimensional array

Abstract data (array) $p[i]$

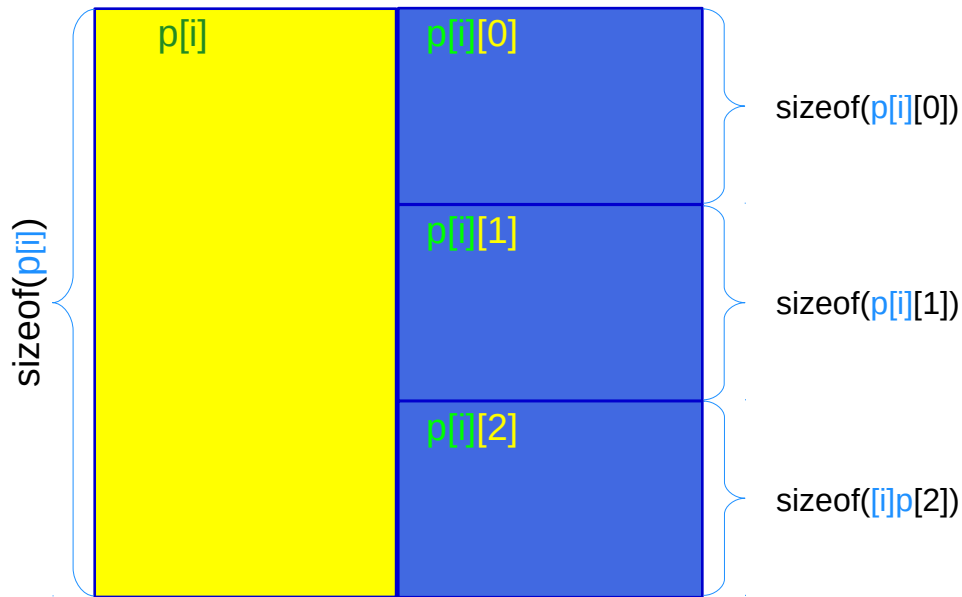

$p[i]$ has an array type (abstract data)
 $p[i]$ is the name of an array
 $p[i]$ has the size of the whole array

Virtual array pointer $p[i]$

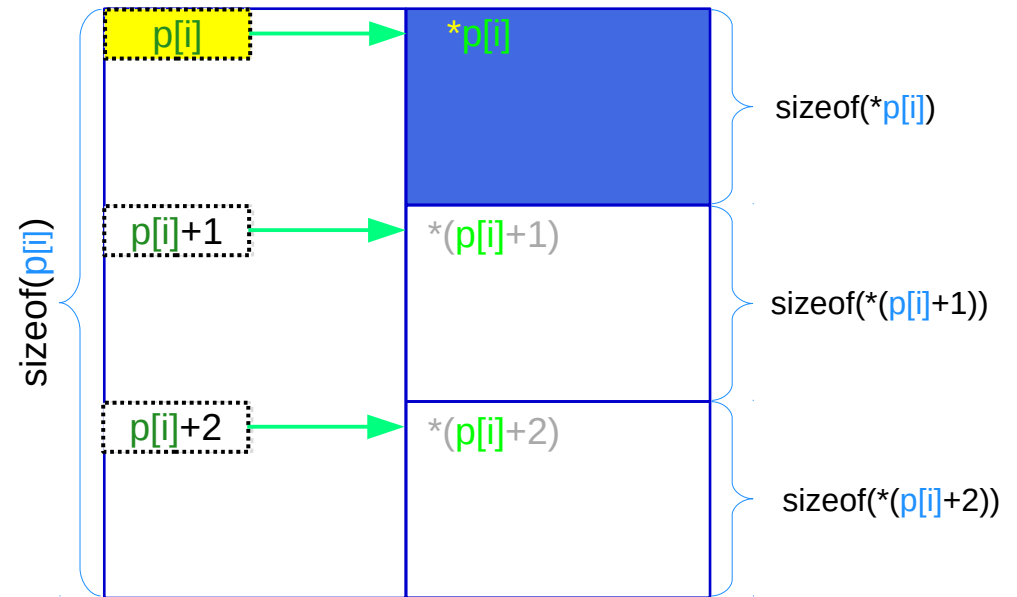

$p[i]$ also has an array pointer type
 $p[i]$ has the value of the starting address
 $p[i]$ is a virtual array pointer

Virtual pointers to sub-arrays

$p[i] :: T^*$

array pointer type

$*p[i], *p[i+1] :: T$

array type

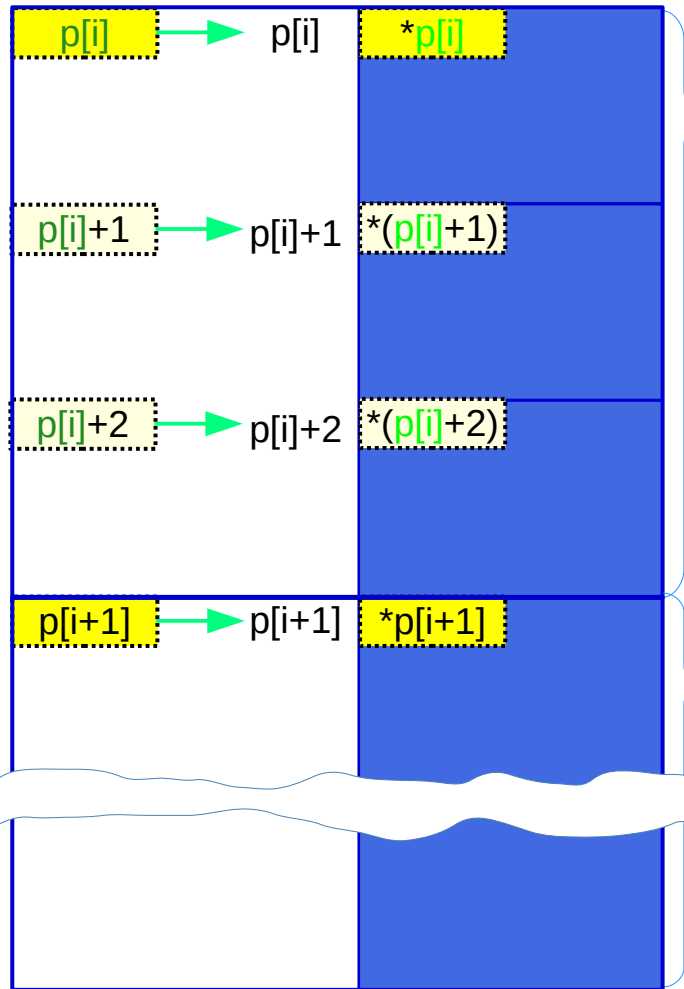

$\text{sizeof}(p[i])$

$$= \text{sizeof}(*p[i]) * N$$

$$= \text{sizeof}(p[i][0]) * N$$

$\text{sizeof}(p[i+1])$

$$= \text{sizeof}(*p[i+1]) * N$$

$$= \text{sizeof}(p[i+1][0]) * N$$

size = $\text{sizeof}(*p[i]) = \text{sizeof}(p[i][0])$

size = $\text{sizeof}(*(p[i]+1)) = \text{sizeof}(p[i][1])$

size = $\text{sizeof}(*(p[i]+2)) = \text{sizeof}(p[i][2])$

3-d array structure – virtual pointer representation

```
int c[2][3][4];
```

```
*(***(c +i) +j) +k)
```

- Hierarchical
- Nested Structure
- Virtual Array Pointers to abstract data (subarrays)
- Contiguous and Linear Data Layout
- Row Major Order

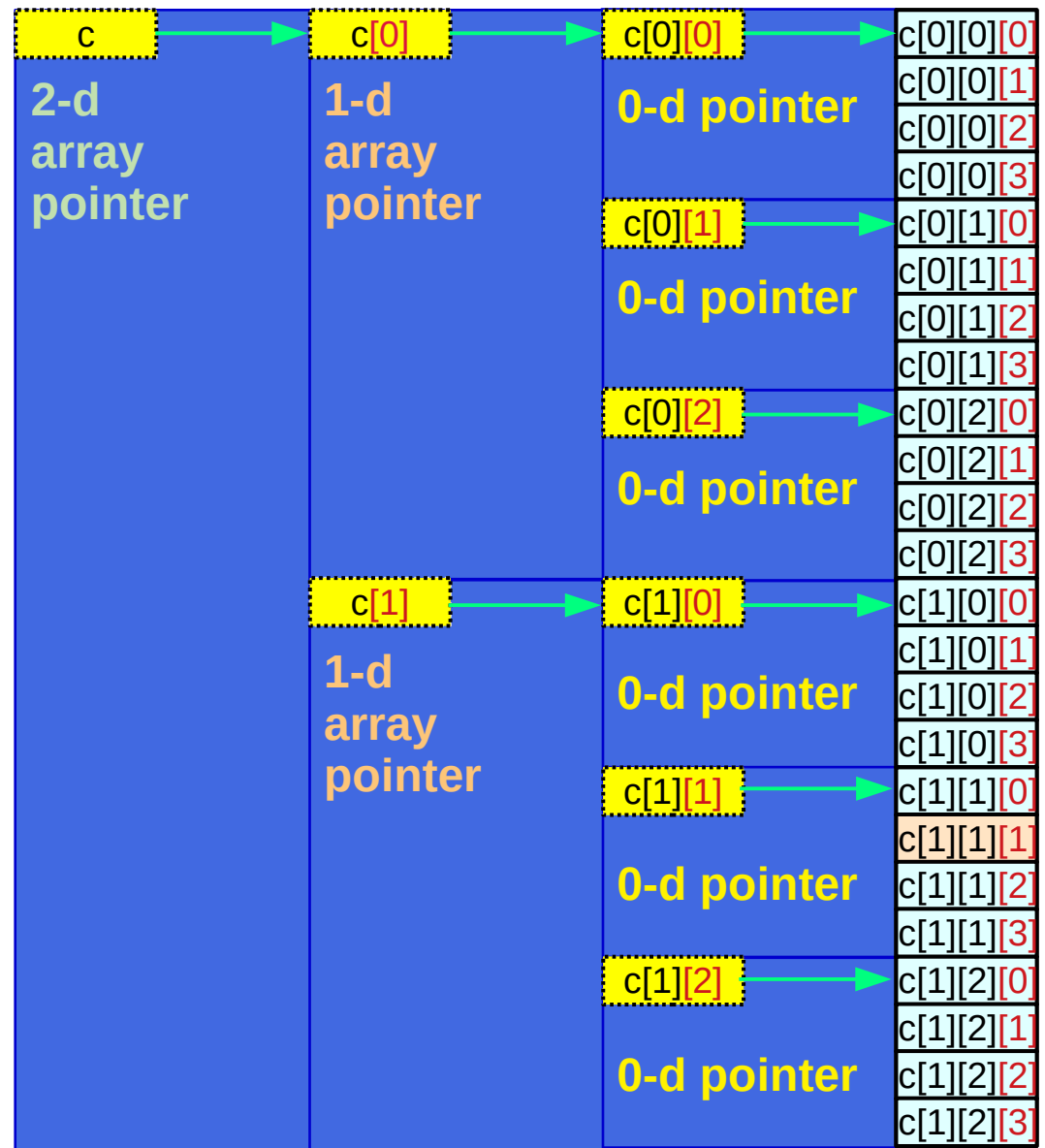

3-d array structure – abstract data representation

```
int c[2][3][4];
```

```
((c [i])[j])[k]
```

- Hierarchical
- Nested Structure
- Virtual Array Pointers to abstract data (subarrays)
- Contiguous and Linear Data Layout
- Row Major Order

c 3-d array name	c[0] 2-d array name	c[0][0] 1-d array name	c[0][0][0] c[0][0][1] c[0][0][2] c[0][0][3]
		c[0][1] 1-d array name	c[0][1][0] c[0][1][1] c[0][1][2] c[0][1][3]
		c[0][2] 1-d array name	c[0][2][0] c[0][2][1] c[0][2][2] c[0][2][3]
	c[1] 2-d array name	c[1][0] 1-d array name	c[1][0][0] c[1][0][1] c[1][0][2] c[1][0][3]
		c[1][1] 1-d array name	c[1][1][0] c[1][1][1] c[1][1][2] c[1][1][3]
		c[1][2] 1-d array name	c[1][2][0] c[1][2][1] c[1][2][2] c[1][2][3]

Array **a** and virtual pointer **a**

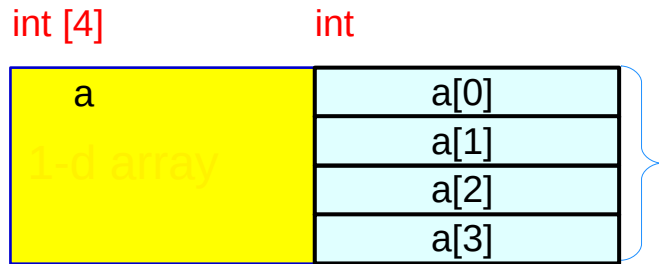

1-d array **a** specific array type

$\text{sizeof}(a)$

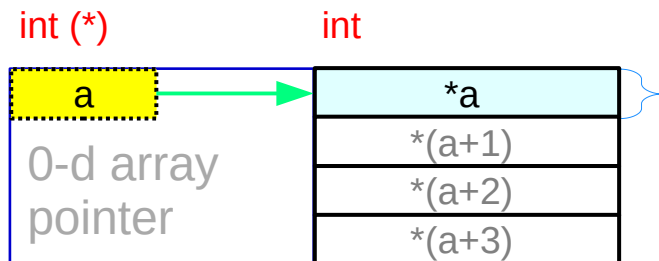

pointer **a** general pointer type

$\text{sizeof}(a) = \text{sizeof}(*a) * 4$

- a** is the name of a 1-d array
- a** also has a pointer type
- a** has the size of the array
- a** has the value of the starting address

a is a virtual array pointer

Array **b** and virtual pointer **b**

2-d array **b** specific array type

`sizeof(b)`

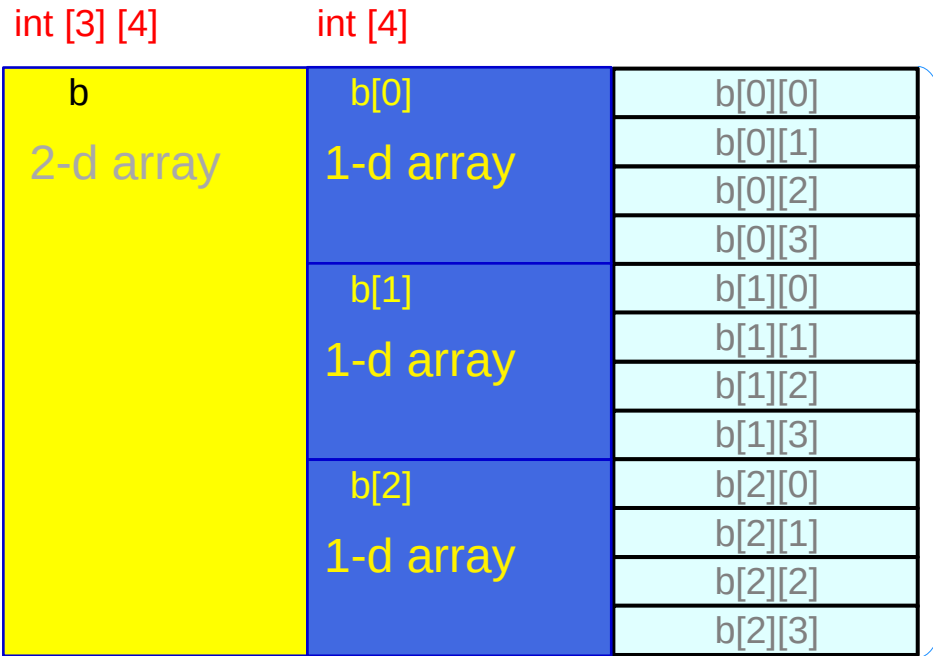

b is the name of a 2-d array
b has the size of the array

1-d array pointer **b** general pointer type

`sizeof(b) = sizeof(*b) * 3`

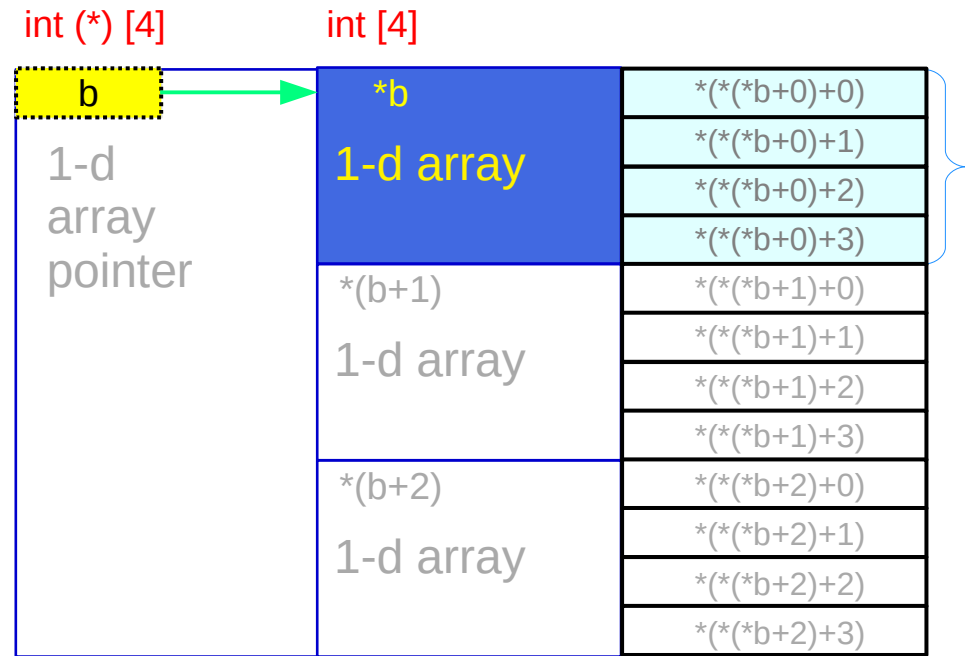

b also has a 1-d array pointer type
b has the value of the starting address

b is a virtual array pointer

Array c

3-d array c

specific array type

sizeof(c)

c is the name of a 3-d array
c has the size of the array

int [2][3][4]	int [3][4]	int [4]	
c 3-d array	c[0] 2-d array	c[0][0] 1-d array	c[0][0][0]
			c[0][0][1]
			c[0][0][2]
			c[0][0][3]
		c[0][1] 1-d array	c[0][1][0]
			c[0][1][1]
			c[0][1][2]
			c[0][1][3]
		c[0][2] 1-d array	c[0][2][0]
			c[0][2][1]
			c[0][2][2]
			c[0][2][3]
	c[1] 2-d array	c[1][0] 1-d array	c[1][0][0]
			c[1][0][1]
			c[1][0][2]
			c[1][0][3]
		c[1][1] 1-d array	c[1][1][0]
			c[1][1][1]
			c[1][1][2]
			c[1][1][3]
		c[1][2] 1-d array	c[1][2][0]
			c[1][2][1]
			c[1][2][2]
			c[1][2][3]

Virtual pointer **c**

2-d array pointer **c**

general pointer type

$\text{sizeof}(c) = \text{sizeof}(*c) * 2$

- c** also has a 2-d array pointer type
- c** has the value of the starting address
- c** is a virtual array pointer

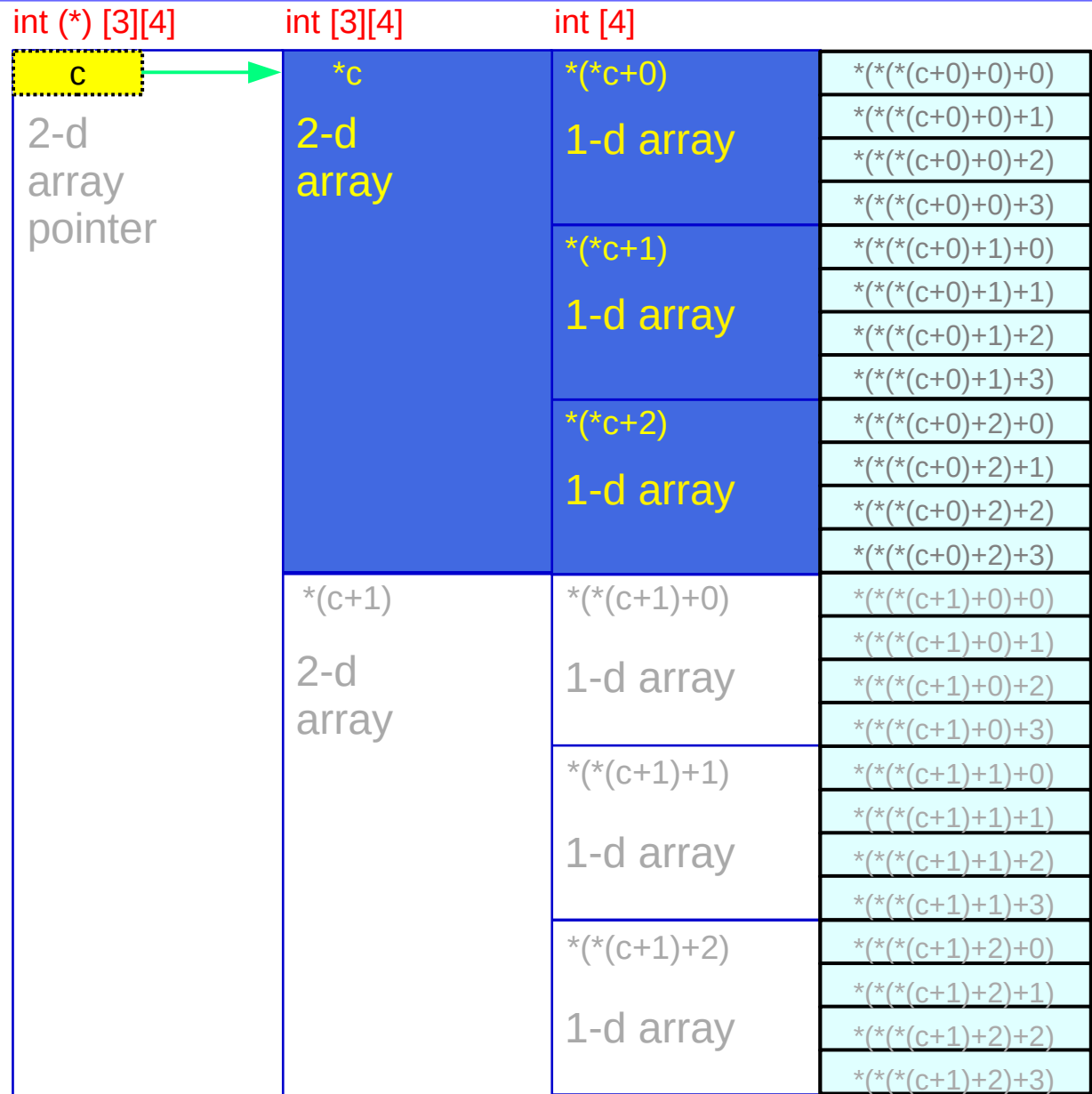

Types of virtual array pointers in a **3-d** array

```
int c[2][3][4];
```

c[i][j][k]

c[i][j]
[k]

c[i]
[j] [k]

c
[i] [j] [k]

int

int [4]
[k]

int [3][4]
[j] [k]

int [2][3][4]
[i] [j] [k]

array type (name)

int

int (*)
[k]

int (*)[4]
[j] [k]

int (*)[3][4]
[i] [j] [k]

array pointer type

Sizes of virtual array pointers in a **3-d** array

```
int c[2][3][4];
```

$$\begin{aligned} \text{sizeof}(c[i][j][k]) &= \text{sizeof}(\text{int}) \\ \text{sizeof}(c[i][j])_{[k]} &= \text{sizeof}(\text{int}) * 4_{[k]} \\ \text{sizeof}(c[i])_{[j] [k]} &= \text{sizeof}(\text{int}) * 3 * 4_{[j] [k]} \\ \text{sizeof}(c)_{[i] [j] [k]} &= \text{sizeof}(\text{int}) * 2 * 3 * 4_{[i] [j] [k]} \end{aligned}$$

Element Size

Addresses of virtual array pointers in a 3-d array

```
int c[2][3][4];
```

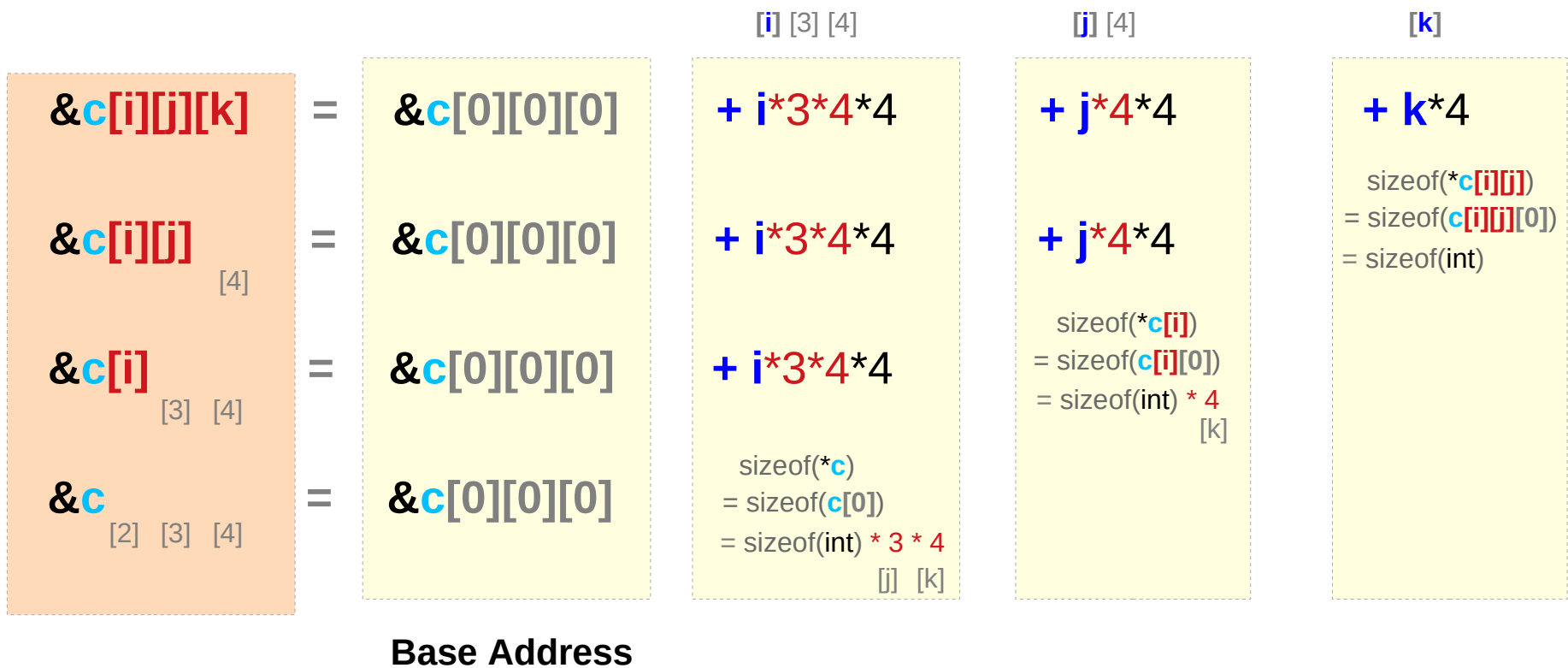

Values of virtual array pointers in a 3-d array

```
int c[2][3][4];
```

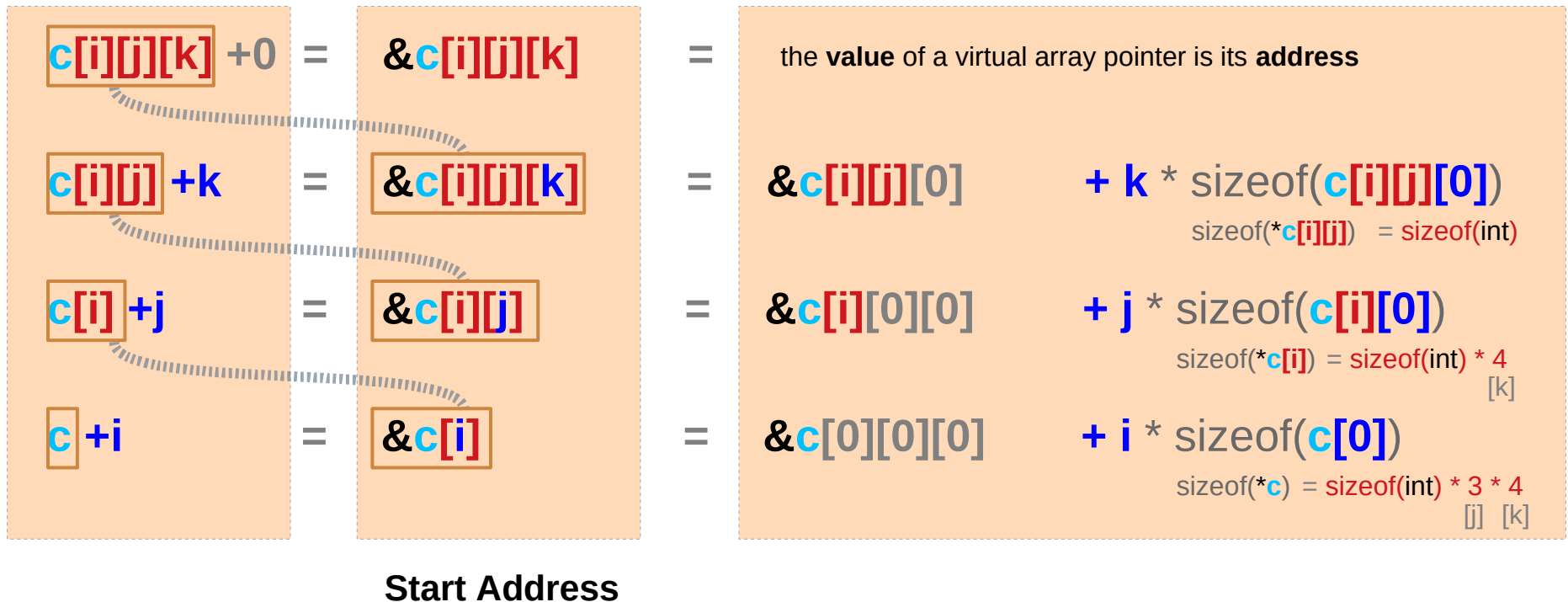

Virtual array pointers and abstract data in a 3-d array

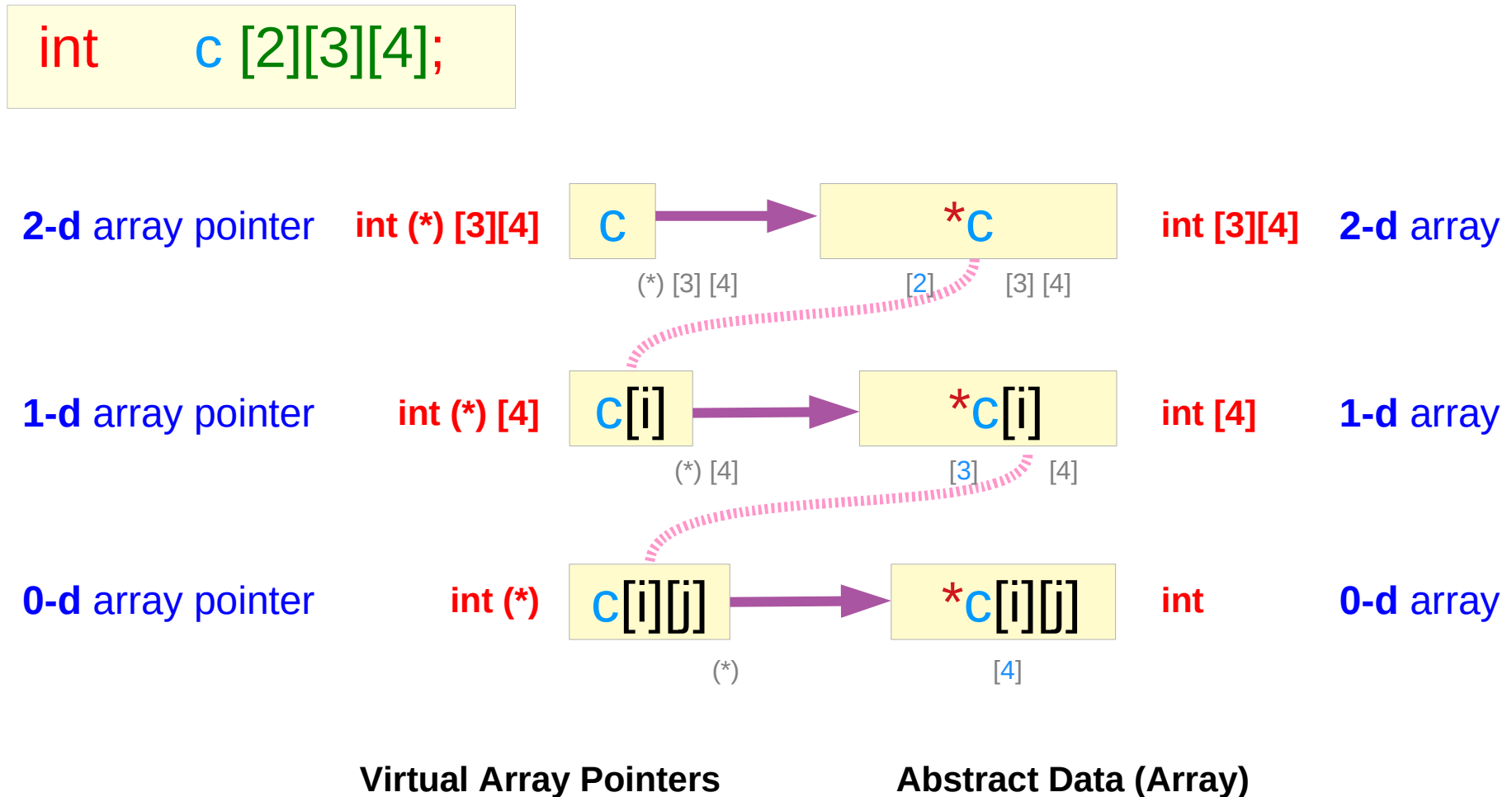

Dual types in a 3-d array

```
int c [2][3][4];
```

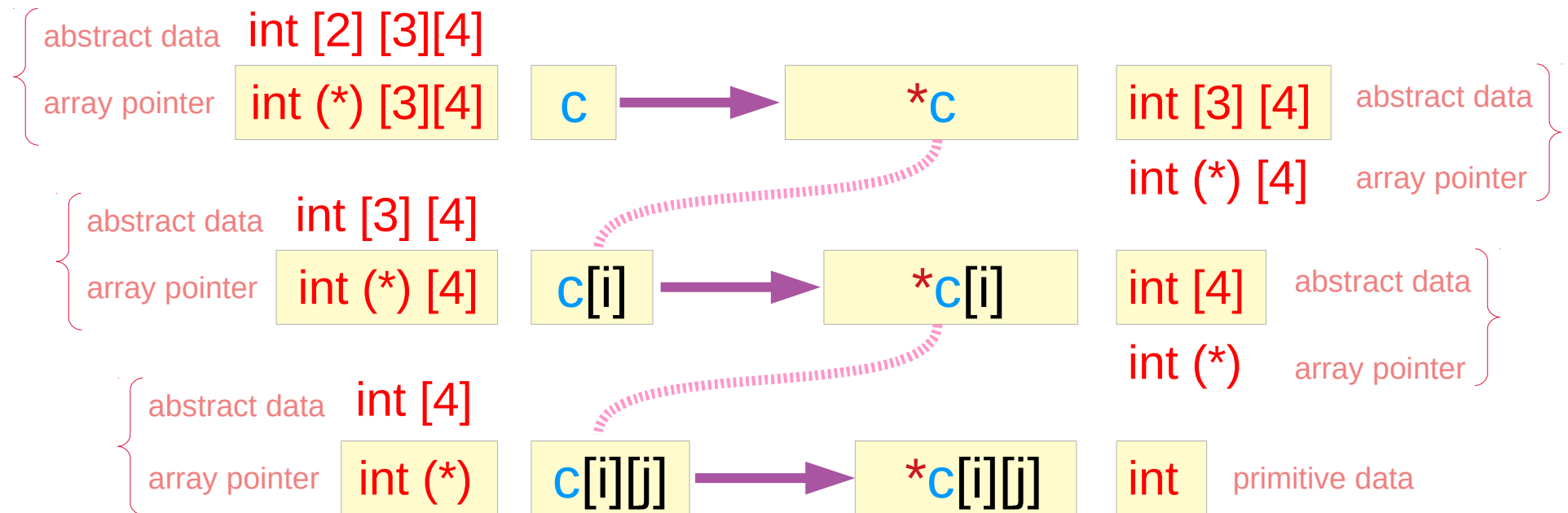

Pointed array sizes in a 3-d array

```
int c [2][3][4];
```

the size of a pointer type is fixed
Here, the sizes of virtual pointers are shown
i.e, the sizes of different abstract data types

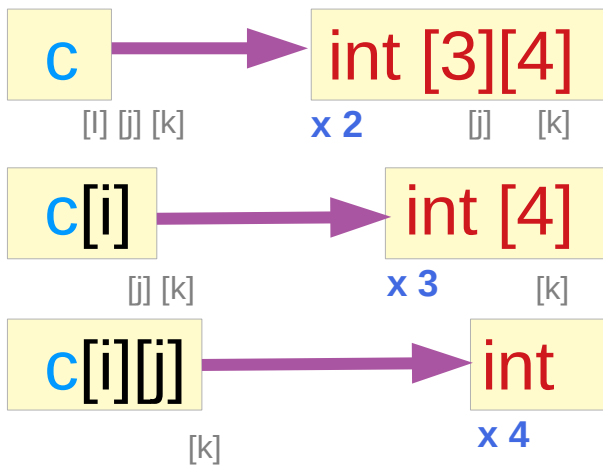

`sizeof(*c)` = `sizeof(int [3][4])`

`sizeof(*c[i])` = `sizeof(int [4])`

`sizeof(*c[i][j])` = `sizeof(int)`

all are sizes of arrays

`c`, `c[i]`, `c[i][j]` are virtual array pointers
and they are also abstract data (arrays)

when sizes are considered,
view them as abstract data (arrays)

Virtual array pointer sizes in a 3-d array

```
int c [2][3][4];
```

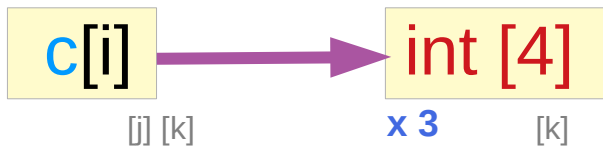
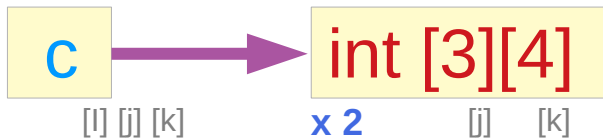

size of a virtual array pointer

=

size of the pointed abstract data type

*

the number of such data

`sizeof(c)`

= 2

*

`sizeof(*c)`

`sizeof(c[i])`

= 3

*

`sizeof(*c[i])`

`sizeof(c[i][j])`

= 4

*

`sizeof(*c[i][j])`

`sizeof(Virtual Array Pointer) = sizeof(Array of the dual type)`

Virtual pointer sizes are subarray sizes

```
int c [2][3][4];
```

`c` → `int [3][4]`
[i] [j] [k] [j] [k]

`c[i]` → `int [4]`
[j] [k] [k]

`c[i][j]` → `int`
[k]

not real array pointers
virtual array pointers

$\text{sizeof}(\text{Virtual Array Pointer}) = \text{sizeof}(\text{Array of the dual type})$



$\text{sizeof}(\text{int [2] [3][4]}) = \text{sizeof}(c) = 2 * 3 * 4 * 4$
 $\text{sizeof}(\text{int (*) [3][4]}) = \text{pointer size} = 4 \text{ or } 8$

$\text{sizeof}(\text{int [3] [4]}) = \text{sizeof}(c[i]) = 3 * 4 * 4$
 $\text{sizeof}(\text{int (*) [4]}) = \text{pointer size} = 4 \text{ or } 8$

$\text{sizeof}(\text{int [4]}) = \text{sizeof}(c[i][j]) = 4 * 4$
 $\text{sizeof}(\text{int [4]}) = \text{pointer size} = 4 \text{ or } 8$

4 bytes for 32-bit machines
8 bytes for 64-bit machines

Subarrays c , $c[i]$, $c[i][j]$ in a 3-d array

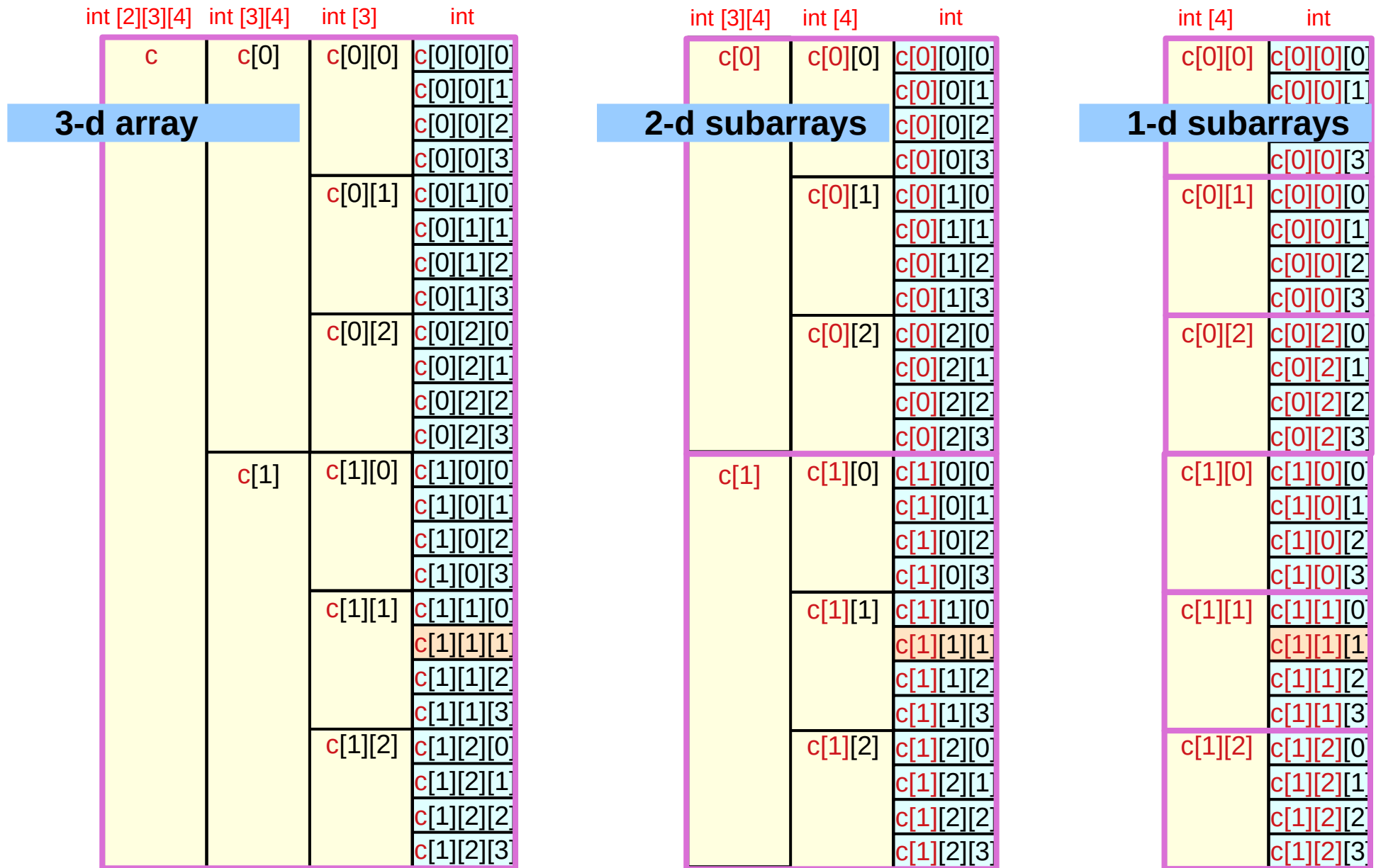

Virtual array pointers c , $c[i]$, $c[i][j]$ in a 3-d array

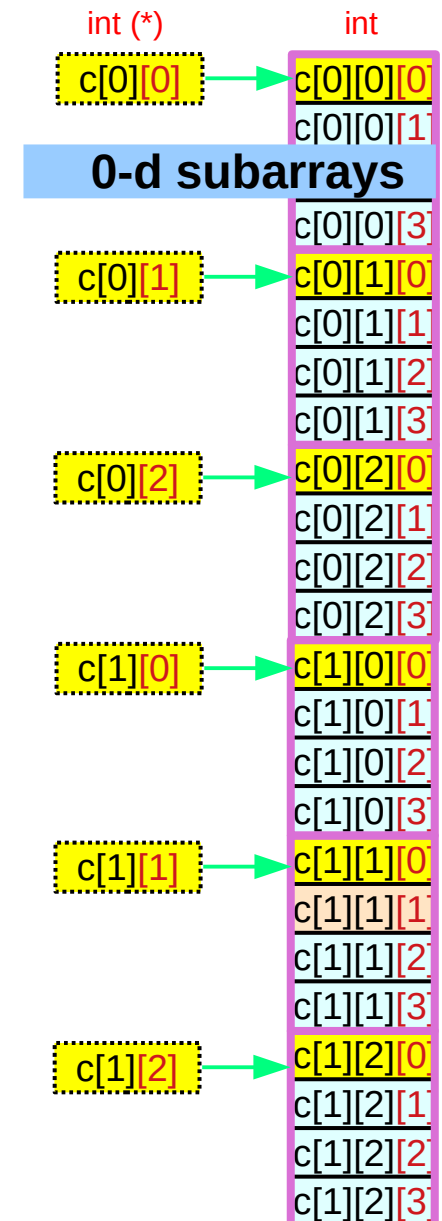
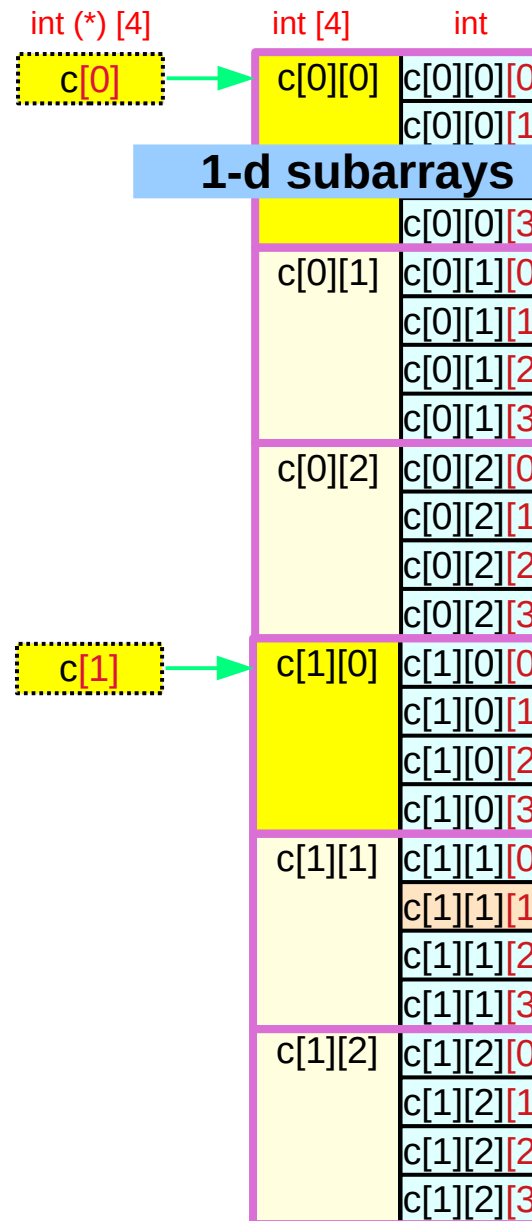
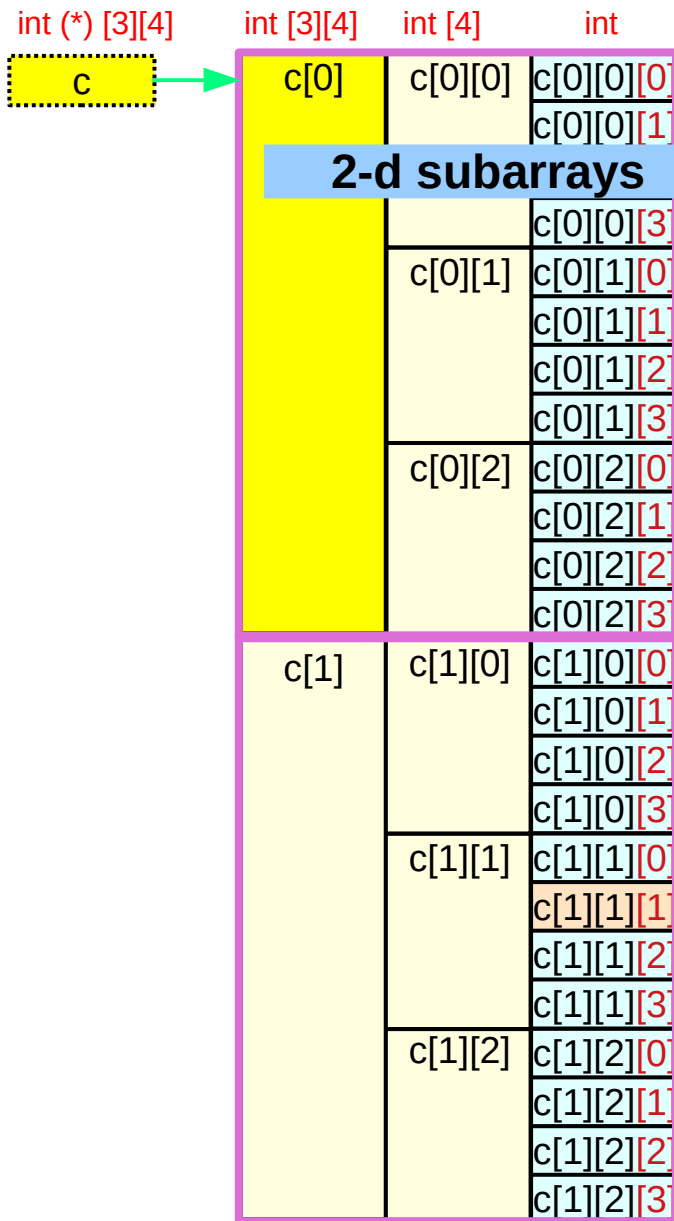

Abstract data \mathbf{c} , $\mathbf{c}[i]$, $\mathbf{c}[i][j]$ – start addresses and sizes

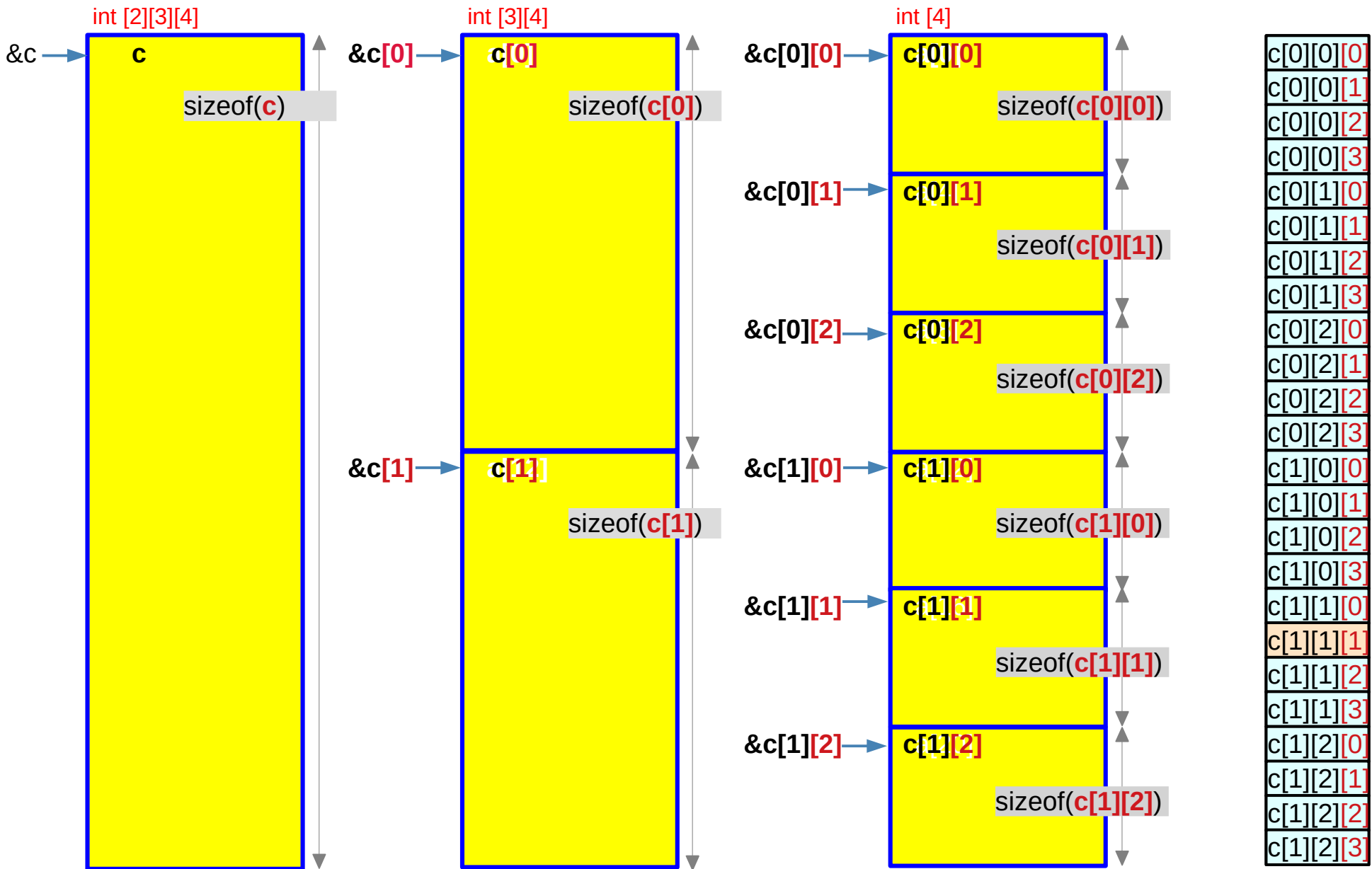

Virtual array pointer c , $c[i]$, $c[i][j]$ – values (addresses)

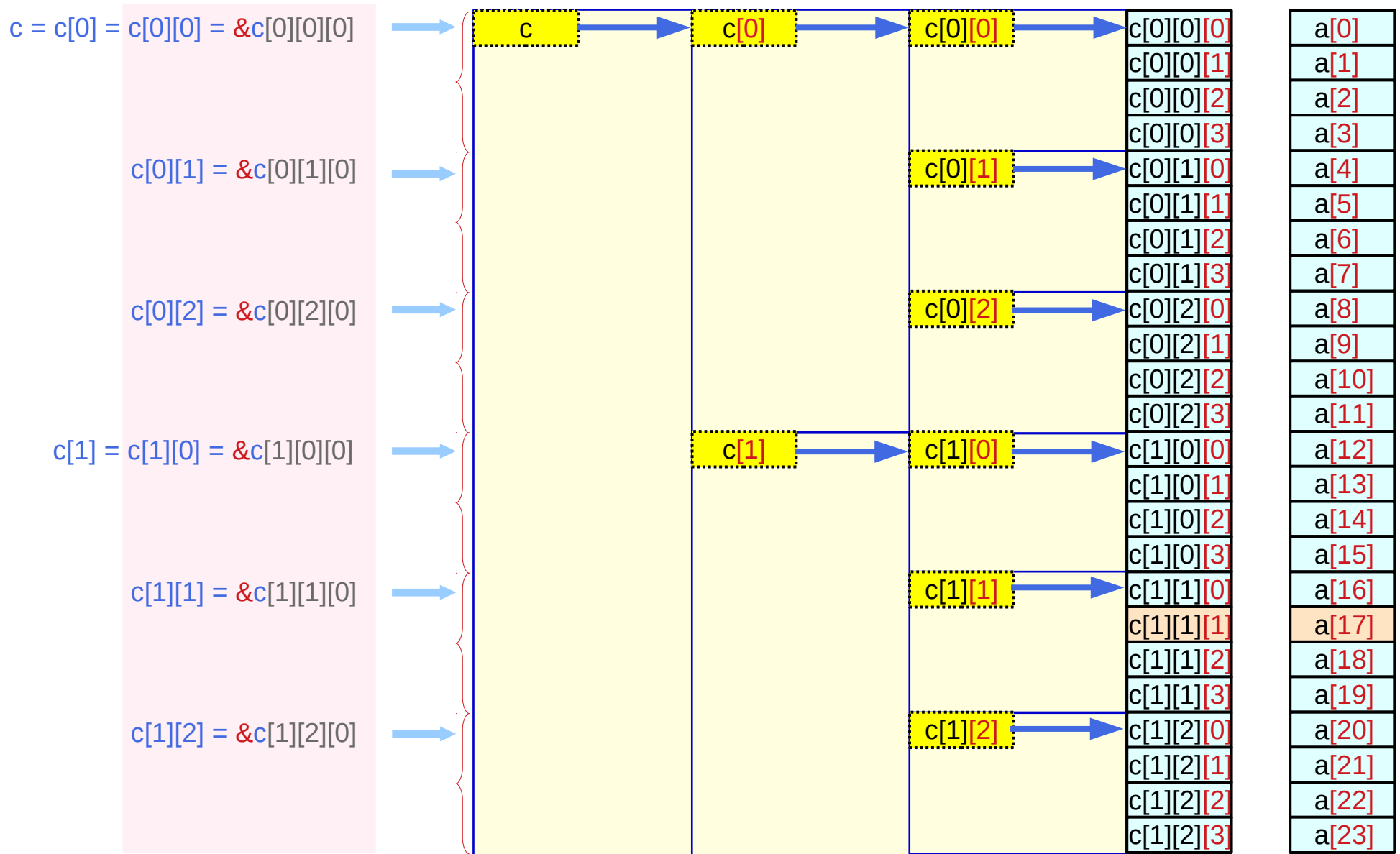

Virtual array pointer c , $c[i]$, $c[i][j]$ – values and types

$c = c[0] = c[0][0] = \&c[0][0][0]$ means

$c[0][1] = \&c[0][1][0]$ means

$c[0][2] = \&c[0][2][0]$ means

$c[1] = c[1][0] = \&c[1][0][0]$ means

$c[1][1] = \&c[1][1][0]$ means

$c[1][2] = \&c[1][2][0]$ means

$\text{value}(c) = \text{value}(c[0]) = \text{value}(c[0][0]) = \text{value}(\&c[0][0][0])$ $\text{type}(c) \neq \text{type}(c[0]) \neq \text{type}(c[0][0]) = \text{type}(\&c[0][0][0])$ $\text{int} (*) [3][4] \quad \text{int} (*) [4] \quad \text{int} * \quad \text{int} *$	$\text{value}(c[0][1]) = \text{value}(\&c[0][1][0])$ $\text{type}(c[0][1]) = \text{type}(\&c[0][1][0])$ $\text{int} * \quad \text{int} *$
$\text{value}(c[0][2]) = \text{value}(\&c[0][2][0])$ $\text{type}(c[0][2]) = \text{type}(\&c[0][2][0])$ $\text{int} * \quad \text{int} *$	$\text{value}(c[1]) = \text{value}(c[1][0]) = \text{value}(\&c[1][0][0])$ $\text{type}(c[1]) \neq \text{type}(c[1][0]) = \text{type}(\&c[1][0][0])$ $\text{int} (*) [4] \quad \text{int} * \quad \text{int} *$
$\text{value}(c[1][1]) = \text{value}(\&c[1][1][0])$ $\text{type}(c[1][1]) = \text{type}(\&c[1][1][0])$ $\text{int} * \quad \text{int} *$	$\text{value}(c[1][2]) = \text{value}(\&c[1][2][0])$ $\text{type}(c[1][2]) = \text{type}(\&c[1][2][0])$ $\text{int} * \quad \text{int} *$

Virtual array pointer c , $c[i]$, $c[i][j]$ – vertical displacement

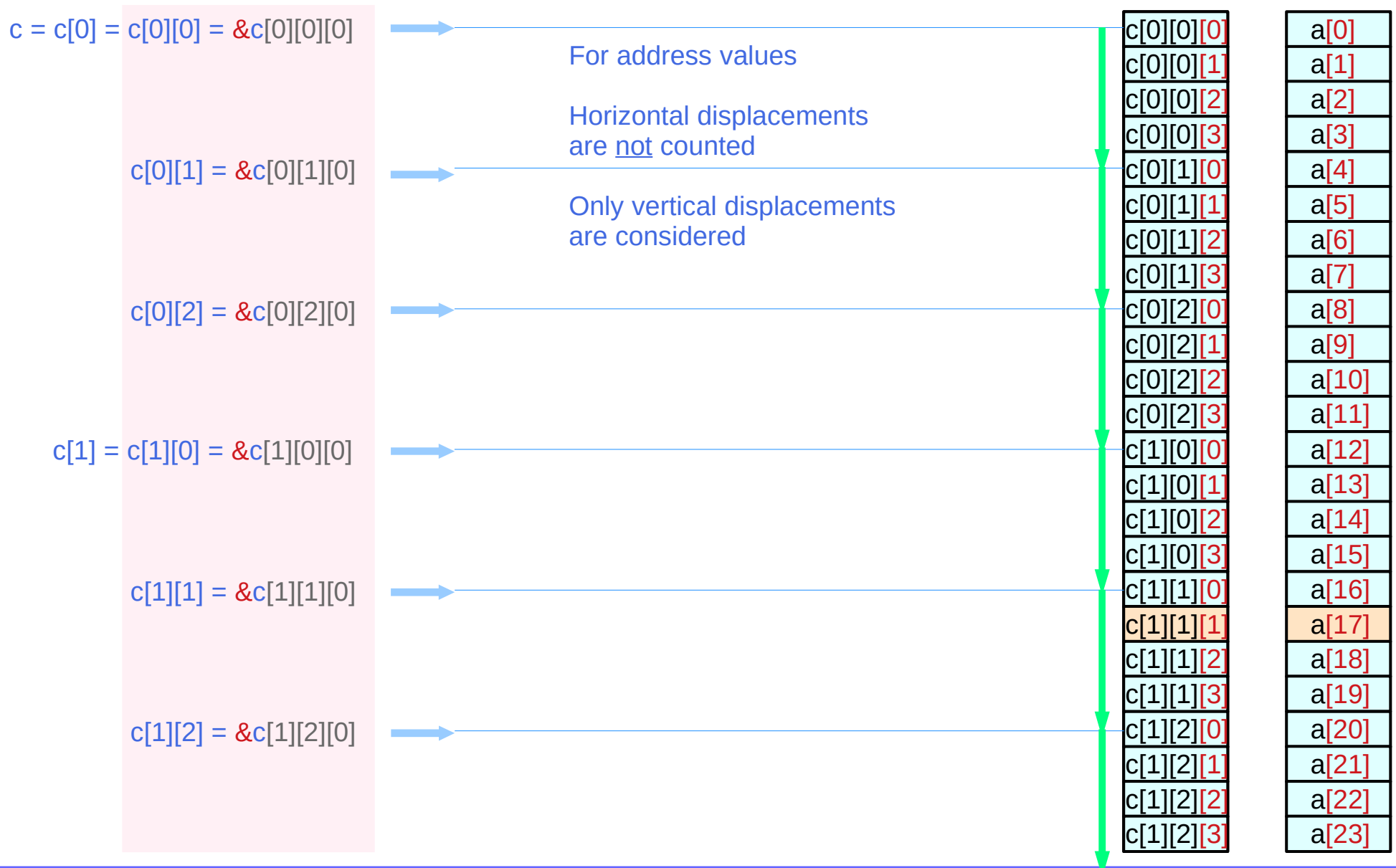

Virtual array pointers – types, sizes, and values

int c[2][3][4];	c[i][j]	c[i][j][0]	
type	int [4] int (*)	int int	<ul style="list-style-type: none"> • abstract data type • array pointer type
size	sizeof(c[i][j]) =	sizeof(c[i][j][0]) * 4	= sizeof(int) * 4
value (address)	c[i][j] =	&c[i][j][0]	
int c[2][3][4];	c[i]	c[i][0]	
type	int [3][4] int (*)[4]	int [4] int (*)	<ul style="list-style-type: none"> • abstract data type • array pointer type
size	sizeof(c[i]) =	sizeof(c[i][0]) * 3	= sizeof(int) * 4 * 3
value (address)	c[i] =	&c[i][0][0]	
int c[2][3][4];	c	c[0]	
type	int [2][3][4] int (*)[3][4]	int [3][4] int (*)[4]	<ul style="list-style-type: none"> • abstract data type • array pointer type
size	sizeof(c) =	sizeof(c[0]) * 2	= sizeof(int) * 4 * 3 * 2
value (address)	c =	&c[0][0][0]	

Summary of virtual array pointers in a 3-d array

$$c[i] \equiv *(c + i)$$

int (*) [3][4] 2-d array pointer c
int [2] [3][4] 3-d array name c

address value $c + i$

$\&c[0][0][0] + i * \text{sizeof}(*c)$
 $\&c[0][0][0] + i * \text{sizeof}(c[0])$
 $\&c[0][0][0] + i * 4 * 3 * 4$

leading elements

$c[0][0][0]$

$$c[i][j] \equiv *(c[i] + j)$$

int (*) [4] 1-d array pointers $c[i]$
Int [3] [4] 2-d array names $c[i]$

address value $c[i] + j$

$\&c[i][0][0] + j * \text{sizeof}(*c[i])$
 $\&c[i][0][0] + j * \text{sizeof}(c[i][0])$
 $\&c[i][0][0] + j * 4 * 4$

leading elements

$c[0][0][0]$

$c[1][0][0]$

$$c[i][j][k] \equiv *(c[i][j] + k)$$

int (*) 0-d array pointers $c[i][j]$
int [4] 1-d array names $c[i][j]$

address value $c[i][j] + k$

$\&c[i][j][0] + k * \text{sizeof}(*c[i][j])$
 $\&c[i][j][0] + k * \text{sizeof}(c[i][j][0])$
 $\&c[i][j][0] + k * 4$

leading elements

$c[0][0][0]$

$c[0][1][0]$

$c[0][2][0]$

$c[1][0][0]$

$c[1][1][0]$

$c[1][2][0]$

Dual type constraints in a multi-dimensional array

Virtual array pointers to subarrays in a 3-d array

virtual 2-d array pointer

sizeof(c) =
sizeof(c[0]) * 2

int (*) [3][4]
c

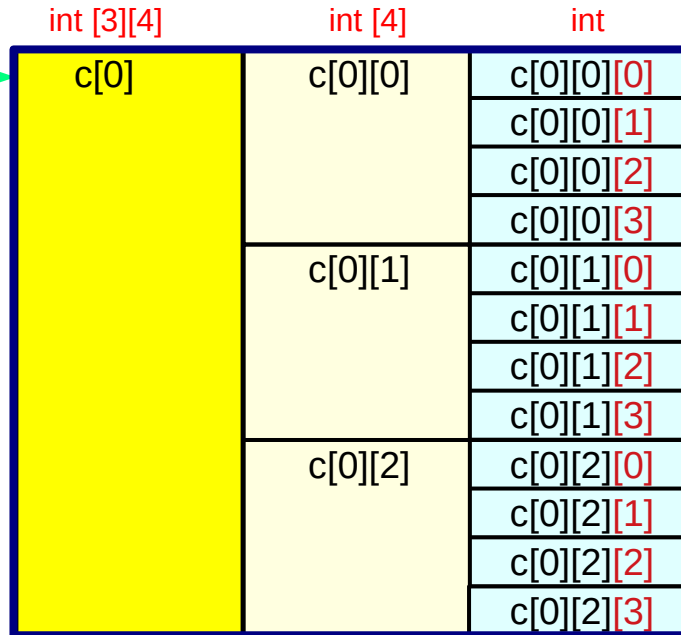

the first 2-d subarray

sizeof(c[0]) =
sizeof(int [3][4])

```
int c [2][3][4];
```

virtual 1-d array pointer

sizeof(c[0]) =
sizeof(c[0][0]) * 3

int (*) [4]
c[0]

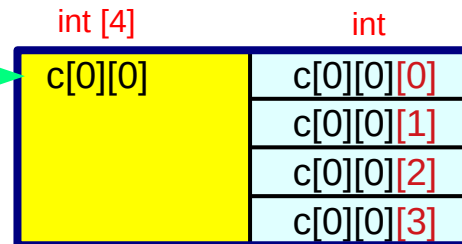

the first 1-d subarray

sizeof(c[0][0]) =
sizeof(int [4])

virtual 0-d array pointer

sizeof(c[0][0]) =
sizeof(c[0][0][0]) * 4

int (*)
c[0][0]

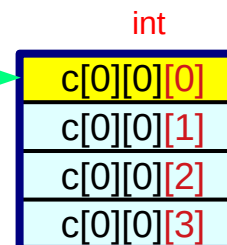

the first 0-d subarray

sizeof(c[0][0][0]) =
sizeof(int)

Virtual array pointer **c**, **c[0]**, **c[0][0]** – types and sizes

Types – array pointers

```
int c [2][3][4];
```

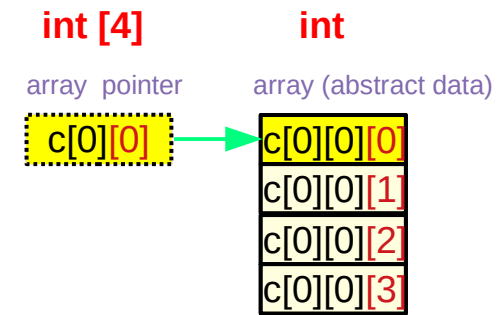
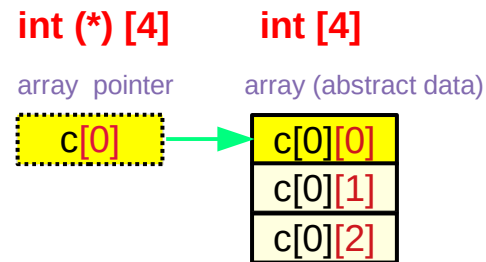
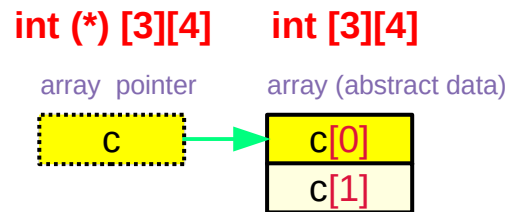

Sizes – abstract data

sizeof(c)
sizeof(int [2][3][4])
sizeof(int) * 2 * 3 * 4

sizeof(int [2][3][4]) = 96
sizeof(int (*)[3][4]) = 4 / 8

sizeof(c[0])
sizeof(int [3][4])
sizeof(int) * 3 * 4

sizeof(int [3][4]) = 48
sizeof(int (*)[4]) = 4 / 8

sizeof(c[0][0])
sizeof(int [4])
sizeof(int) * 4

sizeof(int [4]) = 16
sizeof(int *) = 4 / 8

Contiguous subarrays $c[i]$, $c[i][j]$, $c[i][j][k]$



```
int c [2][3][4];
```

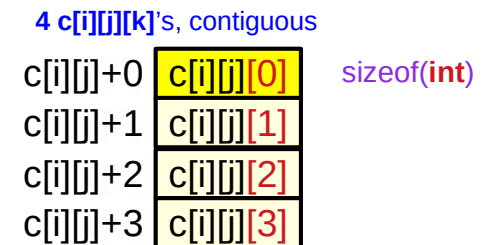
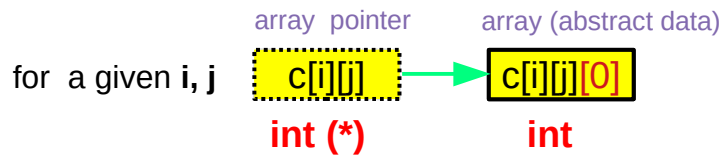
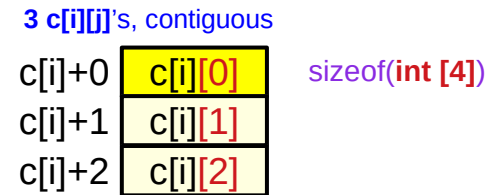
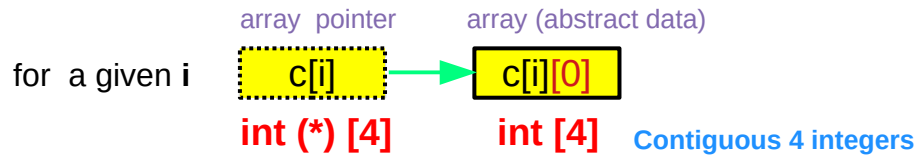
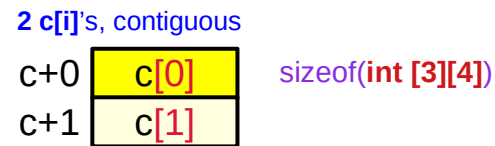
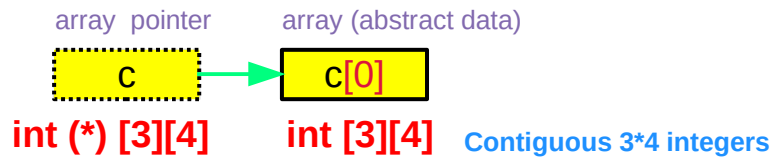

Dual types of `c`, `c[i]`, `c[i][j]`

```
int c [2][3][4];
```

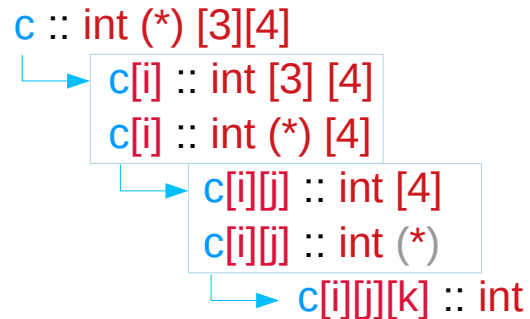

- 2-d array pointers
- 2-d arrays
- 1-d array pointers
- 1-d arrays
- 0-d array pointers
- 0-d arrays (integers)

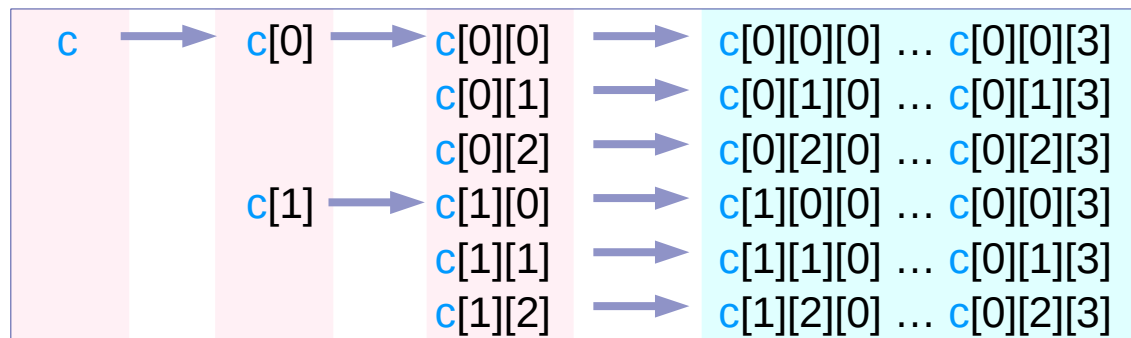

```

int [2] [3][4]  int [3] [4]      int [4]      int      ...      int
int (*) [3][4] int (*) [4]      int (*)     int      ...      int
    
```

Values of virtual array pointers c , $c[i]$, $c[i][j]$

```
int c [2][3][4];
```

virtual array pointers have address values in each row in the following figure have the same address value

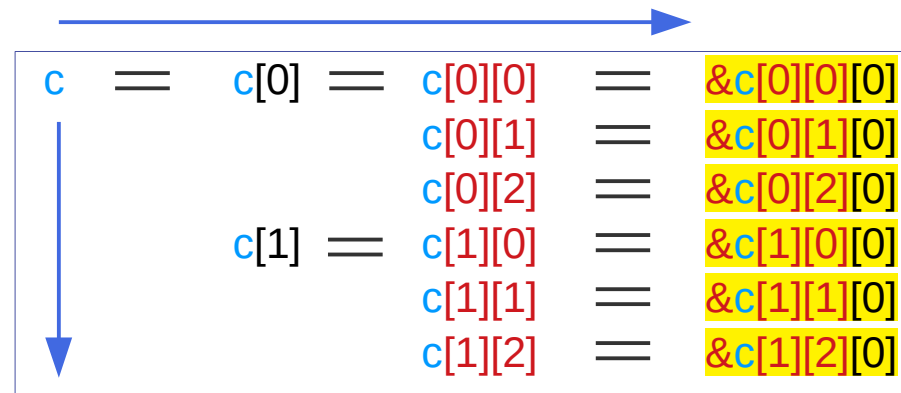

Horizontal displacements are not counted only **vertical displacements** are considered for address values

virtual assignments

```
 $c[i][j] = \&c[i][j][0]$   
 $c[i] = \&c[i][0][0]$   
 $c = \&c[0][0][0]$ 
```

Finding values of virtual array pointers **c**, **c[i]**, **c[i][j]**

```
int c [2][3][4];
```

append **[0]** to the right

c	$\xrightarrow{+[0]}$	c[0]	$\xrightarrow{+[0]}$	c[0][0]	$\xrightarrow{+[0]}$	&c[0][0][0]
				c[0][1]	$\xrightarrow{+[0]}$	&c[0][1][0]
				c[0][2]	$\xrightarrow{+[0]}$	&c[0][2][0]
		c[1]	$\xrightarrow{+[0]}$	c[1][0]	$\xrightarrow{+[0]}$	&c[1][0][0]
				c[1][1]	$\xrightarrow{+[0]}$	&c[1][1][0]
				c[1][2]	$\xrightarrow{+[0]}$	&c[1][2][0]

int (*) [3][4] int (*) [4] int [4] int

c[0][0][0] :
leading
elements
of **c**

c[i][0][0] :
leading
elements
of **c[i]**

c[i][j][0] :
leading
elements
of **c[i][j]**

&c[0][0][0]

&c[0][0][0]

&c[1][0][0]

&c[0][0][0]
&c[0][1][0]
&c[0][2][0]
&c[1][0][0]
&c[1][1][0]
&c[1][2][0]

Finding sub-arrays with the address **&c[i][j][0]**

```
int c [2][3][4];
```

delete [0] from the right

&c[0][0][0]	<u><u>-[0]</u></u>	c[0][0]	<u><u>-[0]</u></u>	c[0]	<u><u>-[0]</u></u>	c
&c[0][1][0]	<u><u>-[0]</u></u>	c[0][1]				
&c[0][2][0]	<u><u>-[0]</u></u>	c[0][2]				
&c[1][0][0]	<u><u>-[0]</u></u>	c[1][0]	<u><u>-[0]</u></u>	c[1]		
&c[1][1][0]	<u><u>-[0]</u></u>	c[1][1]				
&c[1][2][0]	<u><u>-[0]</u></u>	c[1][2]				

int

int [4]

int (*) [4]

int (*) [3][4]

c[0][0][0] is the leading element of c[0][0], c[0], c

c[0][1][0] is the leading element of c[0][1]

c[0][2][0] is the leading element of c[0][2]

c[1][0][0] is the leading element of c[1][0], c[1]

c[1][1][0] is the leading element of c[1][1]

c[1][2][0] is the leading element of c[1][2]

Dual types in a 3-d array

Abstract data (array) X

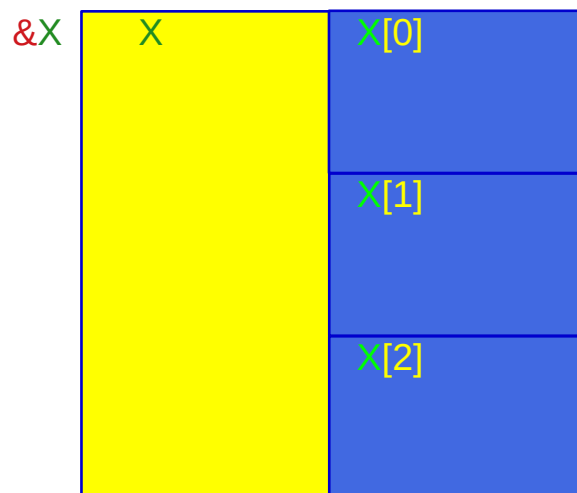

array (abstract data)

array (abstract data)

`c[i][j]` starts from `&c[i][j][0]`
`c[i]` starts from `&c[i][0]`
`c` starts from `&c[0]`

`&c[i][j]` = `&c[i][j][0]`
`&c[i]` = `&c[i][0]`
`&c` = `&c[0]`

Virtual array pointer X

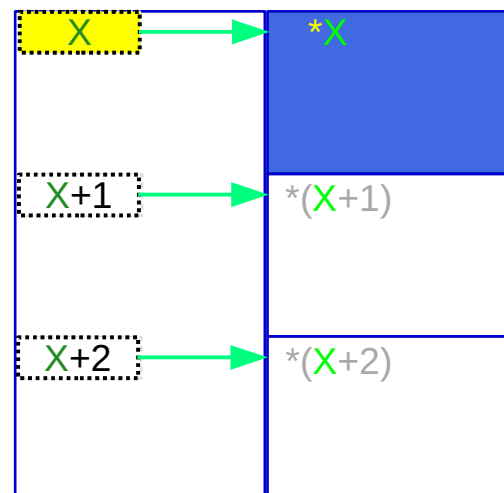

array pointer

array (abstract data)

`c[i][j]` points to `c[i][j][0]`
`c[i]` points to `c[i][0]`
`c` points to `c[0]`

address value

`c[i][j]` = `&c[i][j][0]`
`c[i]` = `&c[i][0]`
`c` = `&c[0]`

Dual type constraints

```
&c[i][j][0] = c[i][j]
&c[i][0]     = c[i]
&c[0]       = c
```

**Virtual
array
pointer**

array pointer		array (abstract data)	
<code>c[i][j]</code>	points to	<code>c[i][j][0]</code>	
<code>c[i]</code>	points to	<code>c[i][0]</code>	
<code>c</code>	points to	<code>c[0]</code>	
address value			

X



```
&c[i][j][0] = &c[i][j]
&c[i][0]     = &c[i]
&c[0]       = &c
```

**Abstract
data
(array)**

array (abstract data)		array (abstract data)	
<code>c[i][j]</code>	starts from	<code>&c[i][j][0]</code>	
<code>c[i]</code>	starts from	<code>&c[i][0]</code>	
<code>c</code>	starts from	<code>&c[0]</code>	

&X X



```
c[i][j] = &c[i][j]
c[i]    = &c[i]
c       = &c
```

array (abstract data)		Address of an array pointer
<code>c[i][j]</code>	pointer value =	pointer address <code>&c[i][j]</code>
<code>c[i]</code>	pointer value =	pointer address <code>&c[i]</code>
<code>c</code>	pointer value =	pointer address <code>&c</code>
X		&X

c[0] = c[0][0] relation

```
int c [2][3][4];
```

```
c == c[0] == c[0][0] == &c[0][0][0]
```

```
value(c[0]) = &c[0][0][0]
```

```
value(c[0][0]) = &c[0][0][0]
```

```
type(c[0]) = int (*)[4]
```

```
type(c[0][0]) = int [4]
```

```
c[0] = c[0][0] means  
value(c[0]) = value(c[0][0])
```

```
c[0] = c[0][0] does not mean  
type(c[0]) = type(c[0][0])
```

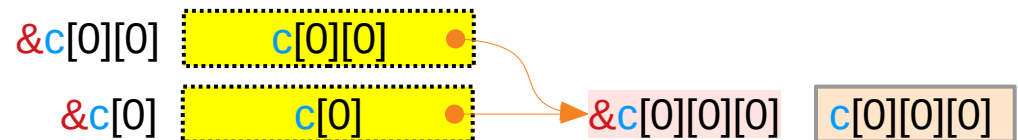

Addresses and Values of `c[0]` and `c[0][0]`

```
int c [2][3][4];
```

`c[0]` → `c[0][0]`

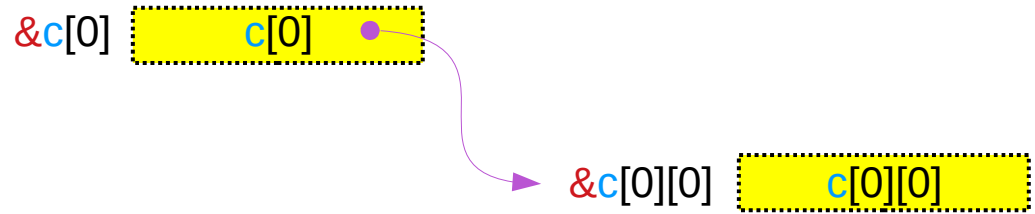

`c[0]` = `c[0][0]` = `&c[0][0][0]`

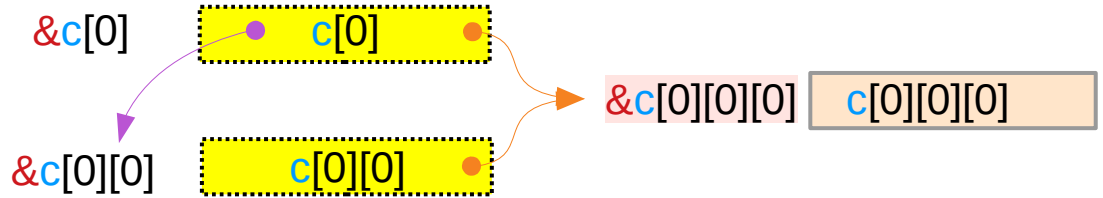

A virtual pointer's address and value are the same

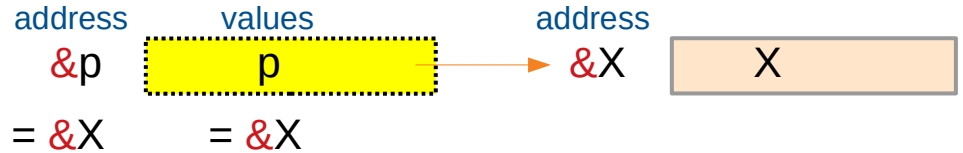

c[i] and c[i][0] point to the same c[i][0][0]

```
int c [2][3][4];
```

```
c = c[0] = c[0][0] = &c[0][0][0]
```

← value
int(*)[3][4] int(*)[4] int(*) int ← type

```
c[1] = c[1][0] = &c[1][0][0]
```

← value
int(*)[4] int(*) int ← type

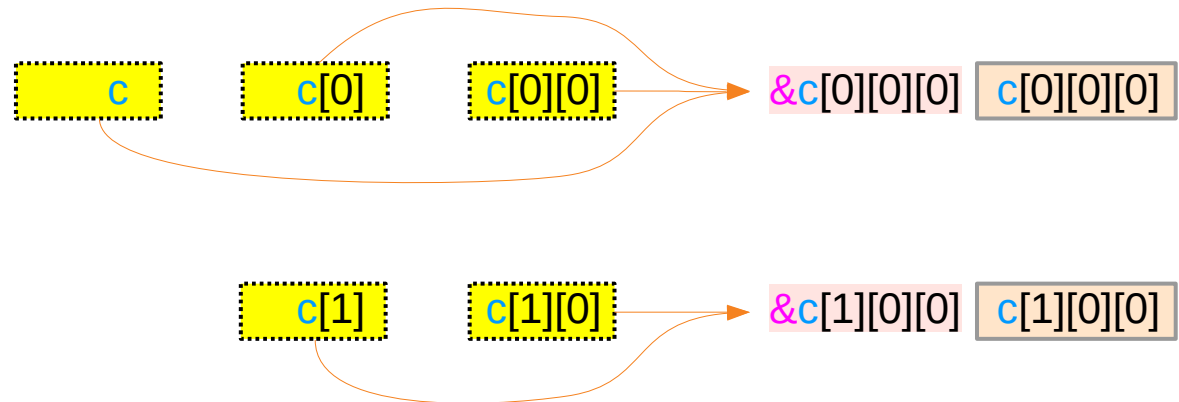

These virtual pointers have different types but the same value (address)

&c[i][0] and &c[i][0][0] – equivalence relations

```
int c [2][3][4];
```

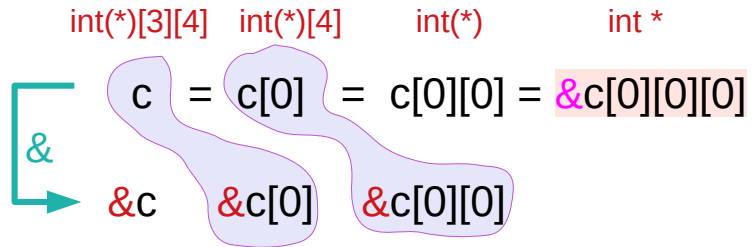

equivalences

```
c ≡ &c[0],  
c[0] ≡ &c[0][0]  
c[0][0] ≡ &c[0][0][0]
```

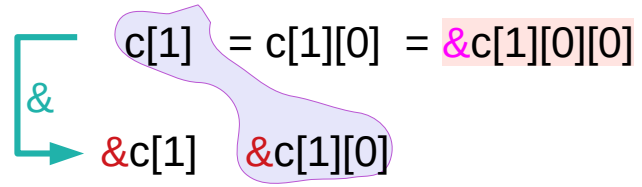

equivalences

```
c[1] ≡ &c[1][0]  
c[1][0] ≡ &c[1][0][0]
```

Horizontal displacements are not counted
only vertical displacements are considered
for address values

equivalences

```
c ≡ &c[0],  
c[i] ≡ &c[i][0]  
c[i][0] ≡ &c[i][0][0]
```

$c[i] = \&c[i]$ and $c[i][0] = \&c[i][0]$

```
int c [2][3][4];
```

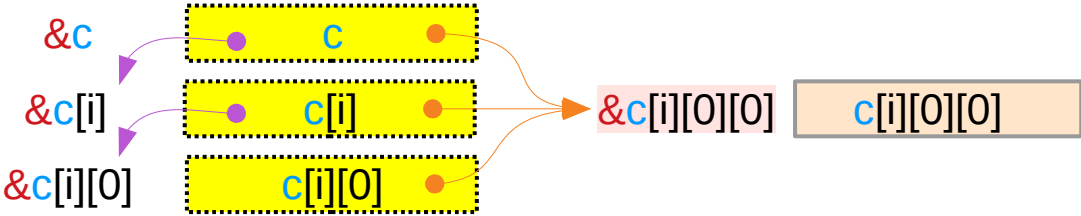
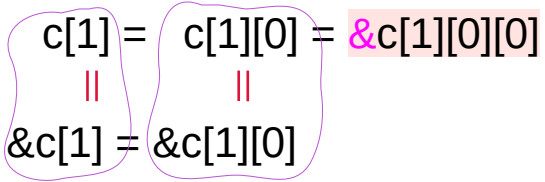
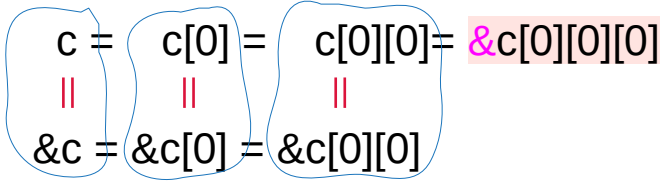

$c[i] = \&c[i]$ and $c[i][0] = \&c[i][0]$

```
int c [2][3][4];
```

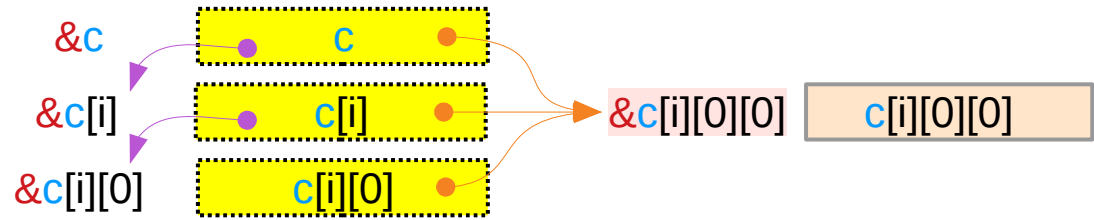
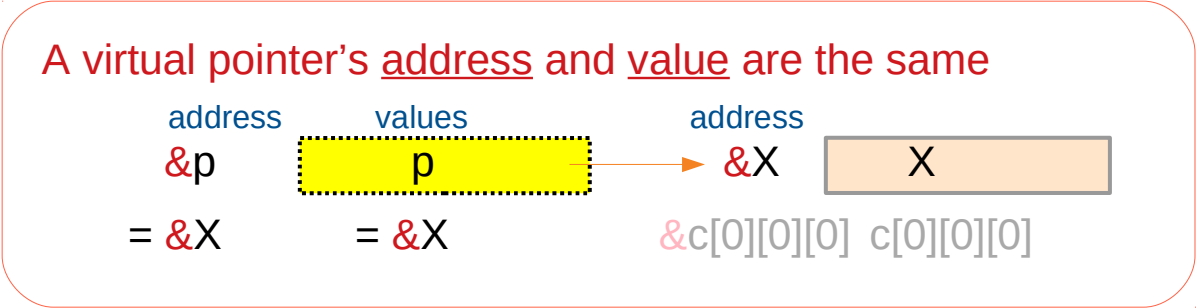

Array Pointers to $c[i][0][0]$

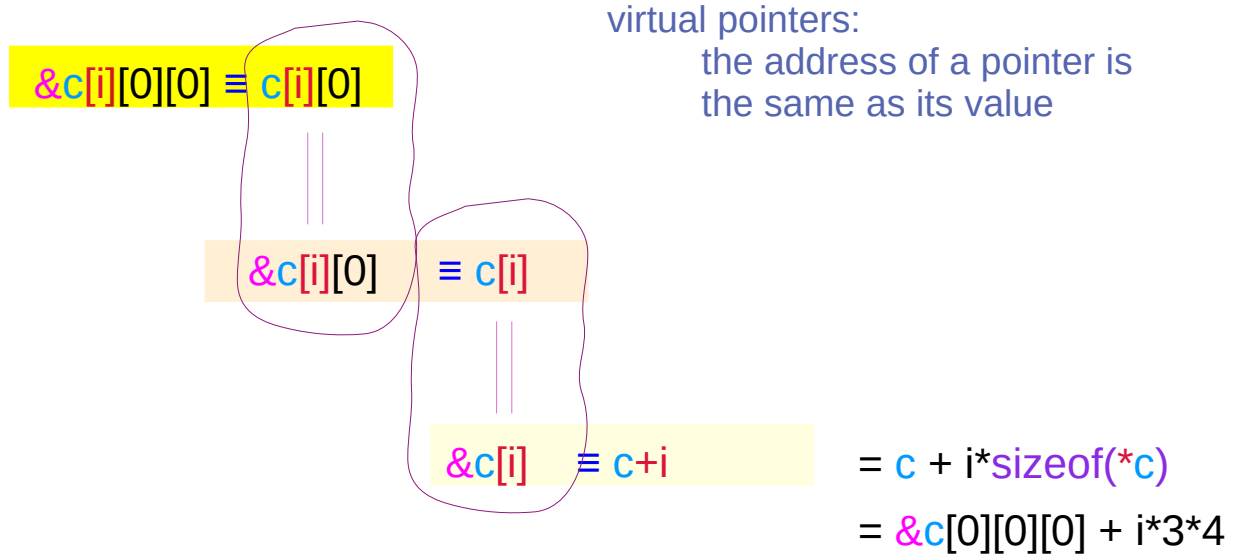

delete [0] from the right

$\&c[0][0][0]$	\equiv	$c[0][0]$	\equiv	$c[0]$	\equiv	c
$\&c[1][0][0]$	\equiv	$c[1][0]$	\equiv	$c[1]$		

Array Pointers to $c[i][j][0]$

$$\&c[i][j][0] \equiv c[i][j]$$

$$\&c[i][j] \equiv c[i] + j$$

$$\begin{aligned} &= c[i] + j * \text{sizeof}(*c[i]) \\ &= c + i * \text{sizeof}(*c) + j * 4 \\ &= \&c[0][0][0] + i * 3 * 4 + j * 4 \end{aligned}$$

delete [0] from the right

$\&c[0][0][0]$	$\underline{\underline{-[0]}}$	$c[0][0]$	$\underline{\underline{-[0]}}$	$c[0]$	$\underline{\underline{-[0]}}$	c
$\&c[0][1][0]$	$\underline{\underline{-[0]}}$	$c[0][1]$				
$\&c[0][2][0]$	$\underline{\underline{-[0]}}$	$c[0][2]$				
$\&c[1][0][0]$	$\underline{\underline{-[0]}}$	$c[1][0]$	$\underline{\underline{-[0]}}$	$c[1]$		
$\&c[1][1][0]$	$\underline{\underline{-[0]}}$	$c[1][1]$				
$\&c[1][2][0]$	$\underline{\underline{-[0]}}$	$c[1][2]$				

Access expressions and dual type constrains

`c [i][j][k]` 3-d access

Hierarchical sub-arrays in a 3-d array

```
int c [L][M][N];
```

```
c [i][j][k]
```

left-to-right associativity

Array Names and Types

Pointers to hierarchical sub-arrays

c	[i]	[j][k]
c[i]	[j]	[k]
c[i][j]	[k]	

c	3-d array names	int (*) [M][N]	2-d array pointer
c[i]	2-d array names	int (*) [N]	1-d array pointer
c[i][j]	1-d array names	int (*)	0-d array pointer

Associativity and Equivalence Relations

left-to-right associativity

$$((c[i])[j])[k]$$

$$\equiv$$

left-to-right associativity

$$*(*(*(c+i)+j)+k)$$

$$X[n]$$

$$\equiv$$

$$*(X+n)$$

given $c[i][j]$

$$c[i][j][k]$$

$$\equiv$$

$$*(c[i][j]+k)$$

for all k

given $c[i]$

$$c[i][j]$$

$$\equiv$$

$$*(c[i]+j)$$

for all j

given c

$$c[i]$$

$$\equiv$$

$$*(c+i)$$

for all i

Requirements for the expression $c[i][j][k]$

for a given $c[i][j]$, for all k

$$c[i][j][k] = *(c[i][j] + k)$$

for a given $c[i]$, for all j

$$c[i][j] = *(c[i] + j)$$

for a given c , for all i

$$c[i] = *(c + i)$$

3 contiguity requirements

for a given $c[i][j]$, contiguous $c[i][j][k]$'s

for a given $c[i]$, contiguous $c[i][j]$'s

for a given c , contiguous $c[i]$'s

for a given subarray pointer
contiguous subarrays

Equivalent requirements for the expression $c[i][j][k]$

for all k
for all j
for all i

$$\begin{aligned}c[i][j][k] &= *(c[i][j]+k) \\c[i][j] &= *(c[i]+j) \\c[i] &= *(c+i)\end{aligned}$$



for all k
for all j
for all i

$$\begin{aligned}\&c[i][j][k] &= c[i][j]+k \\ \&c[i][j] &= c[i]+j \\ \&c[i] &= c+i\end{aligned}$$



$$\begin{aligned}c[i][j][0] &= *(c[i][j]) \\c[i][0] &= *(c[i]) \\c[0] &= *(c)\end{aligned}$$

with contiguous subarrays



$$\begin{aligned}\&c[i][j][0] &= c[i][j] \\ \&c[i][0] &= c[i] \\ \&c[0] &= c\end{aligned}$$

with contiguous subarrays

3 contiguity requirements for the expression $c[i][j][k]$

$$\&c[i][j][k] = c[i][j] + k$$

for all k

$$\&c[i][j] = c[i] + j$$

for all j

$$\&c[i] = c + i$$

for all i

$$= c[i][j] + k * \text{sizeof}(c[i][j][0])$$

$$= c[i] + j * \text{sizeof}(c[i][0])$$

$$= c + i * \text{sizeof}(c[0])$$

consecutive $c[i][j][k]$

for all k

consecutive $c[i][j]$

for all j

consecutive $c[i]$

for all i

$$= \&c[i][j][0] + k * 4$$

$$= \&c[i][0][0] + j * 4 * 4$$

$$= \&c[0][0][0] + i * 3 * 4 * 4$$

3-d access pattern $c[i][j][k]$

General requirements

```
c [i][j][k]
```



```
&c[i][j][k] = c[i][j] + k  for all k  
&c[i][j]    = c[i] + j    for all j  
&c[i]       = c + i       for all i
```

Pointer array approach

```
int** c[2];  
int*  b[2*3];  
int   c[2*3*4];
```

```
c[i][j][k] :: int  
c[i][j]    :: int *  
c[i]       :: int **  
c          :: int ***
```

```
c[i] ← &b[i*3]  
b[j] ← &a[j*4]
```

with contiguous a, b, c

Explicit
Arrays of pointers with
Multiple Indirection

N-dim Array approach

```
int c[2][3][4];
```

```
c[i][j][k] :: int  
c[i][j]    :: int (*)  
c[i]       :: int (*)[4]  
c          :: int (*)[3][4]
```

```
c[i][j] ← &c[i][j][0]  
c[i]    ← &c[i][0][0]  
c       ← &c[0][0][0]
```

with contiguous c

Implicit
Nested
Virtual Array Pointers

3-d access pattern $c[i][j][k]$ – array pointer approach

General requirements

```
c [i][j][k]
```



```
&c[i][j][k] = c[i][j] + k   for all k  
&c[i][j]    = c[i] + j     for all j  
&c[i]       = c + i        for all i
```

N-dim Array approach

```
int c[2][3][4];
```

```
c[i][j][k] :: int  
c[i][j]    :: int (*)  
c[i]       :: int (*)[4]  
c          :: int (*)[3][4]
```

```
c[i][j] ← &c[i][j][0]  
c[i]    ← &c[i][0][0]  
c       ← &c[0][0][0]
```

with contiguous c

**Implicit
Nested
Virtual Array Pointers**



Virtual assignments

```
int c [2][3][4];
```



```
c [i][j][k];
```

virtual assignments

```
c ← &c[0][0][0]
c[i] ← &c[i][0][0]
c[i][j] ← &c[i][j][0]
```

row major ordering
contiguous linear layout

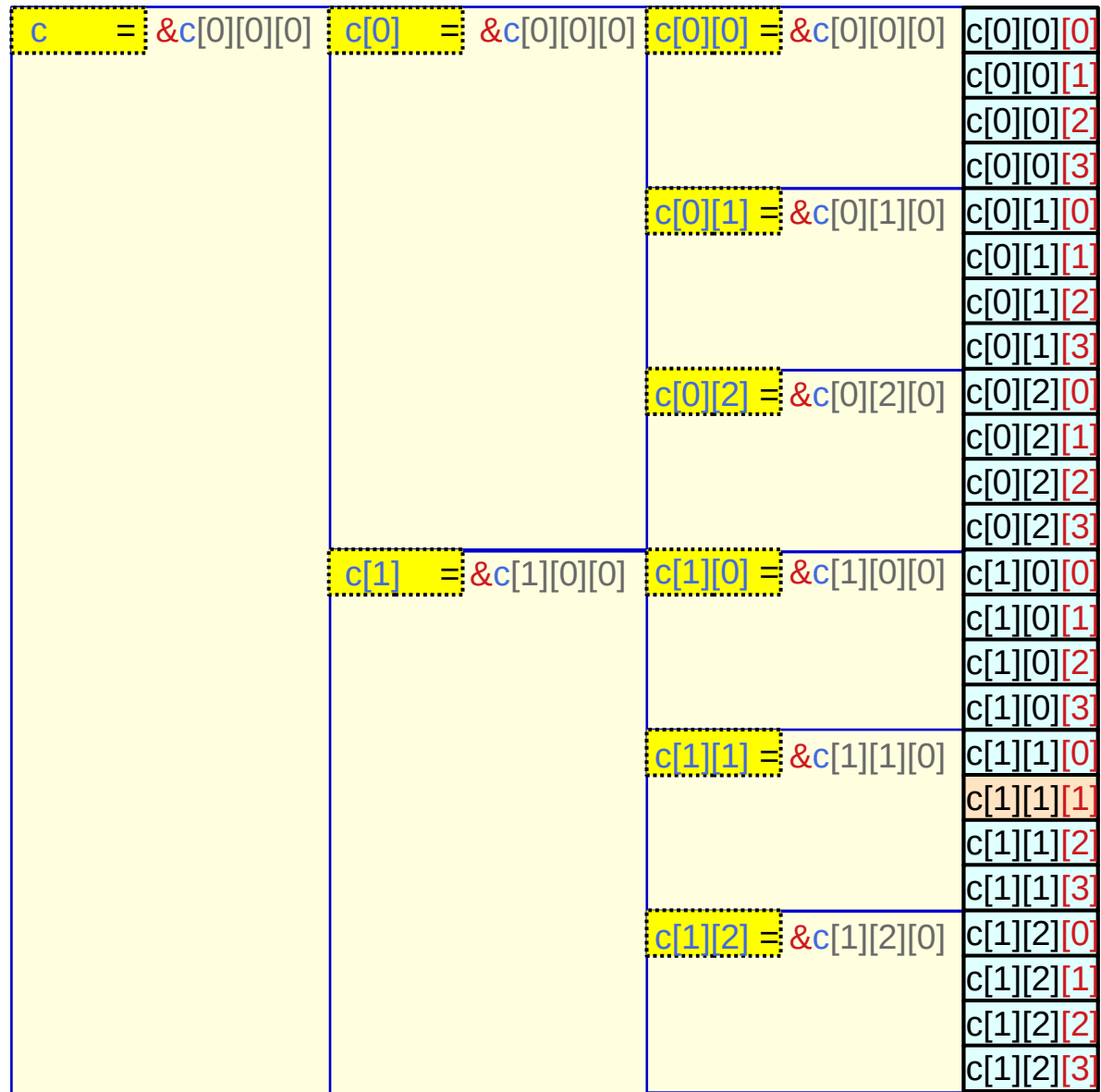

Virtual assignments

```
int c [2][3][4];
```



```
c [i][j][k];
```

virtual assignments

```
c ← &c[0][0][0]
```

```
c[i] ← &c[i][0][0]
```

```
c[i][j] ← &c[i][j][0]
```

row major ordering
contiguous linear layout

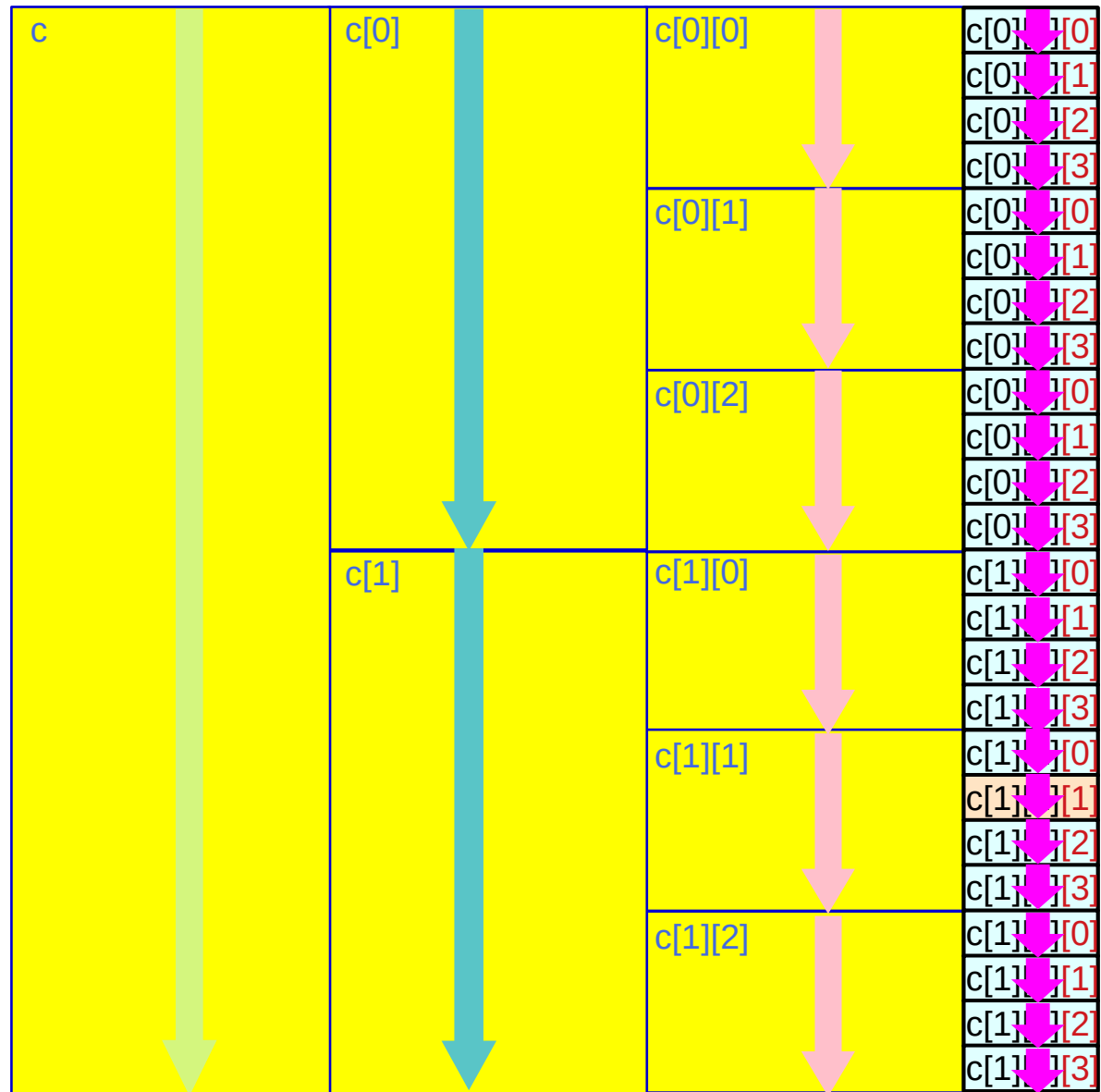

Virtual assignments and type casts

```
int c [2][3][4];
```



```
c [i][j][k];
```

virtual assignments

```
c ← &c[0][0][0]  
c[i] ← &c[i][0][0]  
c[i][j] ← &c[i][j][0]
```

row major ordering
contiguous linear layout

```
c ← (int (*)[3][4]) &c[0][0][0]  
c[i] ← (int (*)[4]) &c[i][0][0]  
c[i][j] ← (int *) &c[i][j][0]
```

type casts address values

if c, c[i], c[i][j] were real pointer variables,
type casts would be needed

Assigning $c[i][j]$, $c[i]$, c

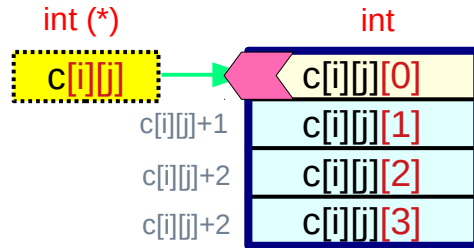

1 integer away

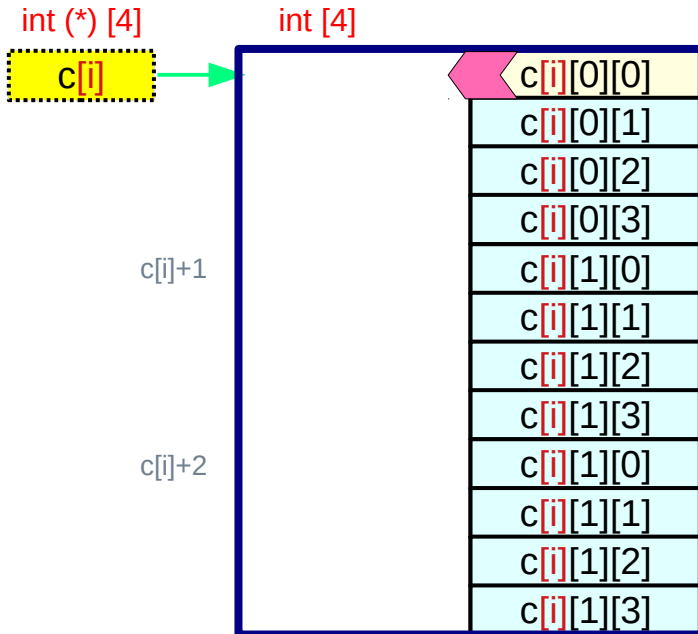

4*1 integers away

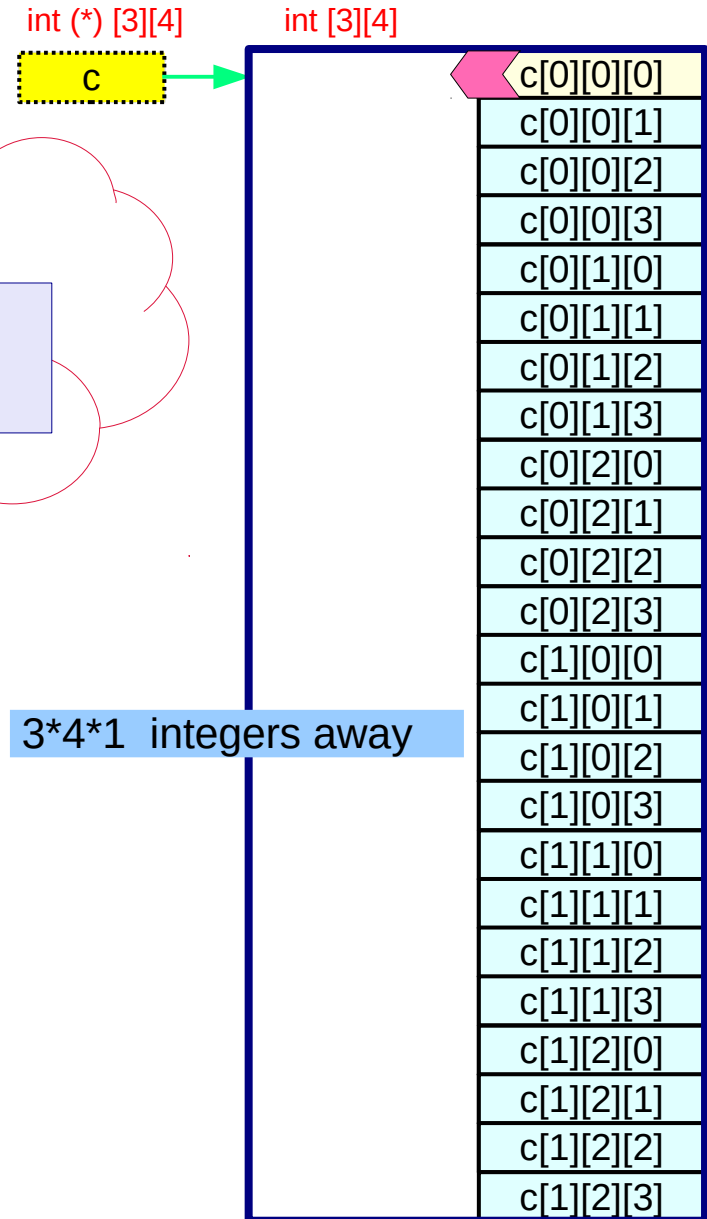
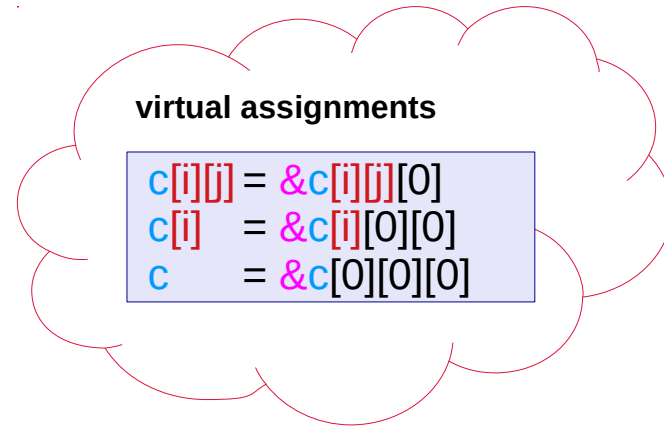

3*4*1 integers away

The addresses $c[i][j]$, $c[i]$, c with dual type constraints

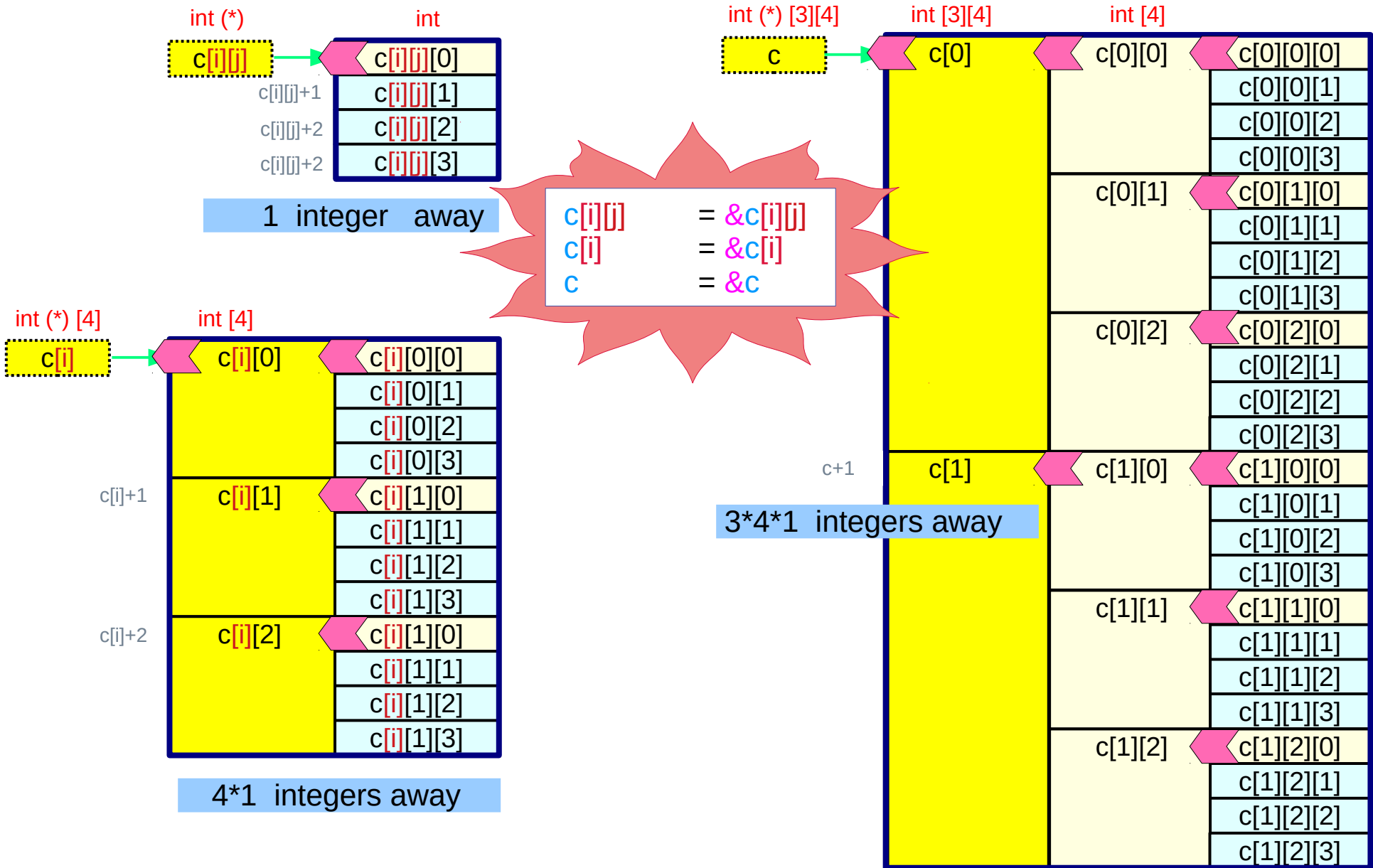

The addresses $c[i][j]+k$, $c[i]+j$, $c+i$

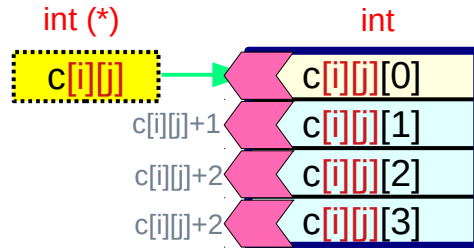

1 integer away

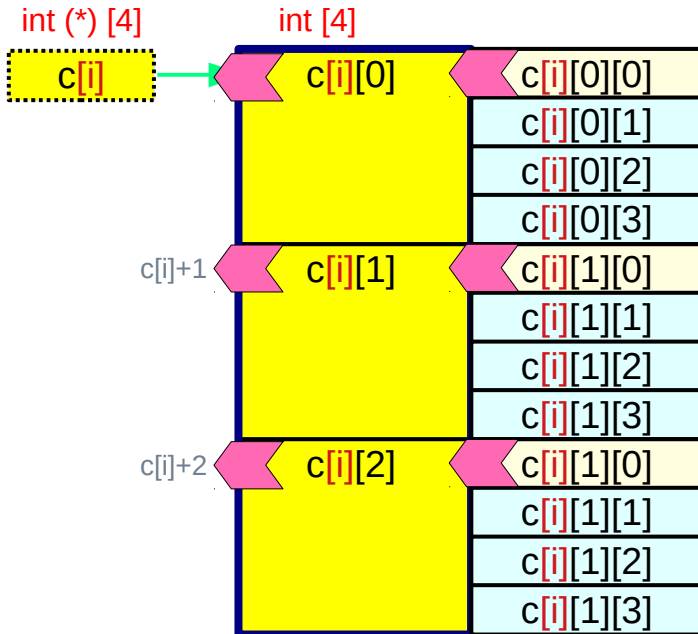

4*1 integers away

$$\begin{aligned} \&c[i][j][k] &= c[i][j]+k && \text{for all } k \\ \&c[i][j] &= c[i]+j && \text{for all } j \\ \&c[i] &= c+i && \text{for all } i \end{aligned}$$

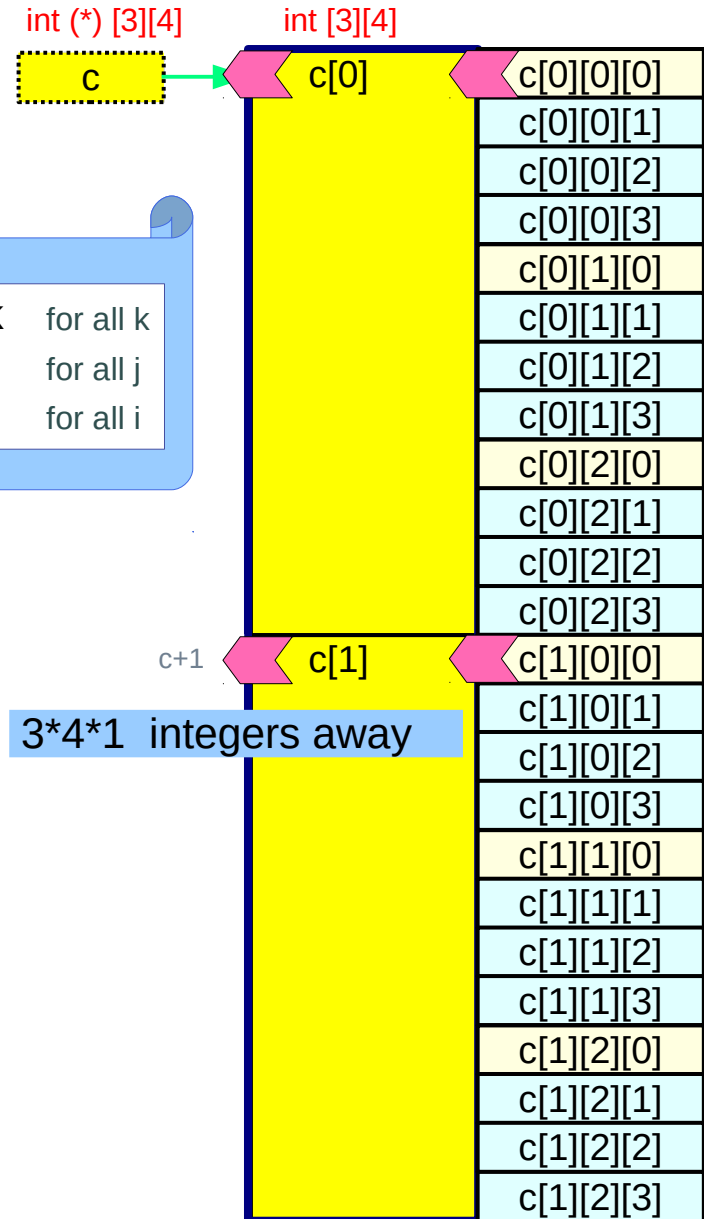

3*4*1 integers away

Assignment → 3 contiguity requirements

multi-dimensional arrays

`c [i][j][k]`

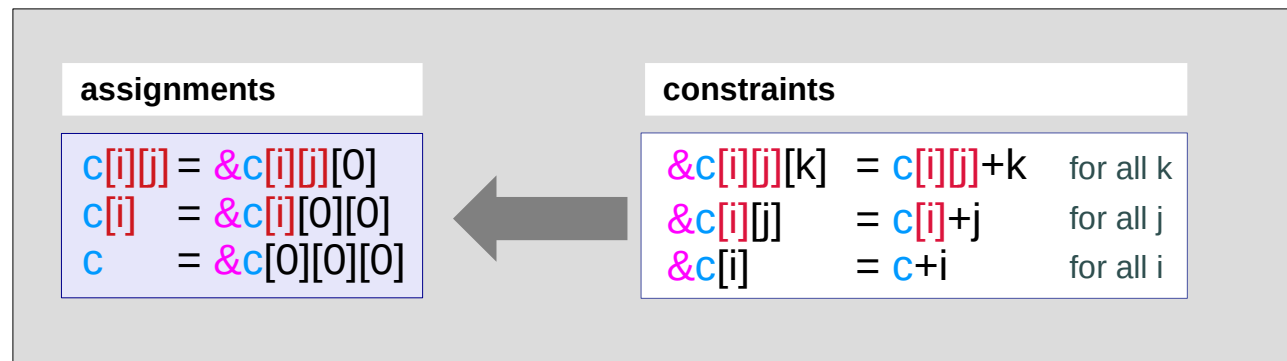
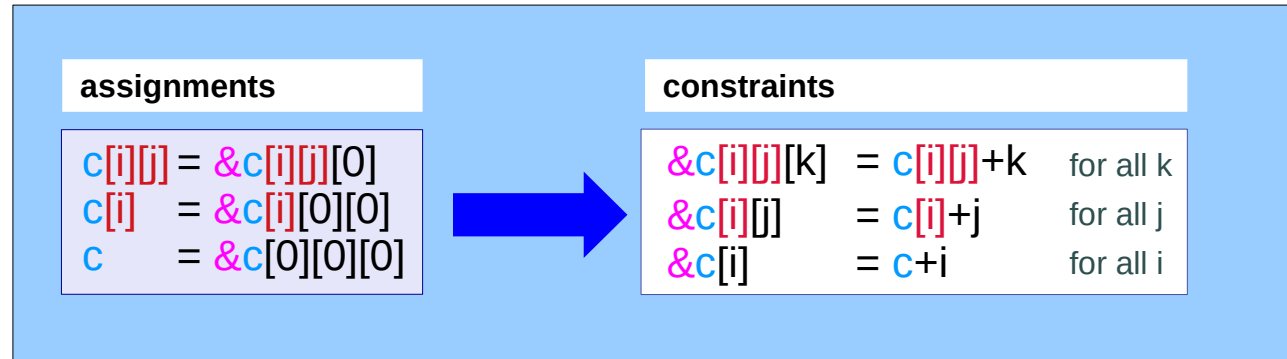

General requirements for `c[i][j][k]`

```
int c [2][3][4];
```

```
&c[i][j][0] = c[i][j]
&c[i][0]    = c[i]
&c[0]      = c
```

with contiguous subarrays

```
&c[i][j][k] = c[i][j]+k for all k
&c[i][j]    = c[i]+j   for all j
&c[i]       = c+i     for all i
```



virtual assignments

```
c[i][j] = &c[i][j][0]
c[i]    = &c[i][0][0]
c       = &c[0][0][0]
```

Virtual assignments

```
int (*) c[i][j] = (int *) &c[i][j][0]
int (*) [4] c[i] = (int (*) [4]) &c[i][0][0]
int (*) [3][4] c = (int (*) [3][4]) &c[0][0][0]
```

Pointer
Types

Sizes of abstract data types

```
int [4] c[i][j] size = 4*4
int [3][4] c[i] size = 3*4*4
int [2][3][4] c size = 2*3*4*4
```

Abstract Data
Types

Strides of array elements

```
c[i][j][0] stride = 4*4
c[i][0][0] stride = 3*4*4
c[0][0][0] stride = 2*3*4*4
```

contiguous

```
c[i][j] contains 4 integers
c[i]    contains 3*4 integers
c       contains 2*3*4 integers
```

```
k=[0:3]
j=[0:2], k=[0:3]
i=[0:1], j=[0:2], k=[0:3]
```

General requirements for $c[i][j][k]$

```
int c [2][3][4];
```

```
&c[i][j][0] = c[i][j]
&c[i][0]    = c[i]
&c[0]      = c
```

with contiguous subarrays

```
&c[i][j][k] = c[i][j]+k for all k
&c[i][j]    = c[i]+j   for all j
&c[i]       = c+i     for all i
```



virtual assignments

```
c[i][j] = &c[i][j][0]
c[i]    = &c[i][0][0]
c       = &c[0][0][0]
```

```
c[i][j]
c[i]
c
```

Pointer
Types

has an address of
has an address of
has an address of

```
c[i][j][0]
c[i][0][0]
c[0][0][0]
```

as its value
as its value
as its value

```
c[i][j]+1
c[i]+1
c+1
```

Pointer
Types

has an address of
has an address of
has an address of

```
c[i][j][1]
c[i][1][0]
c[1][0][0]
```

1 integer away
4*1 integers away
3*4*1 integers away

```
c[i][j]+k
c[i]+j
c+i
```

Pointer
Types

has an address of
has an address of
has an address of

```
c[i][j][k]
c[i][j][0]
c[i][0][0]
```

1*k integers away
4*1*j integers away
3*4*1*i integers away

Assignment ← 3 contiguity requirements

multi-dimensional arrays

`c [i][j][k]`

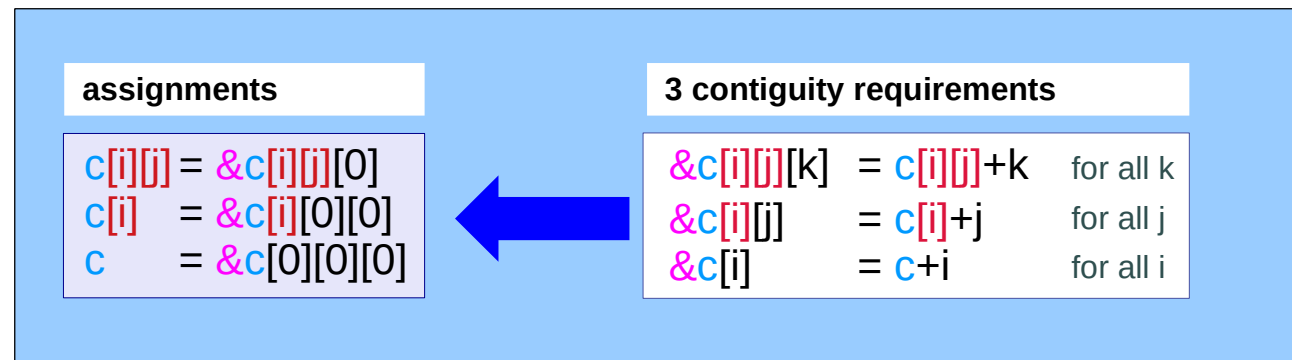
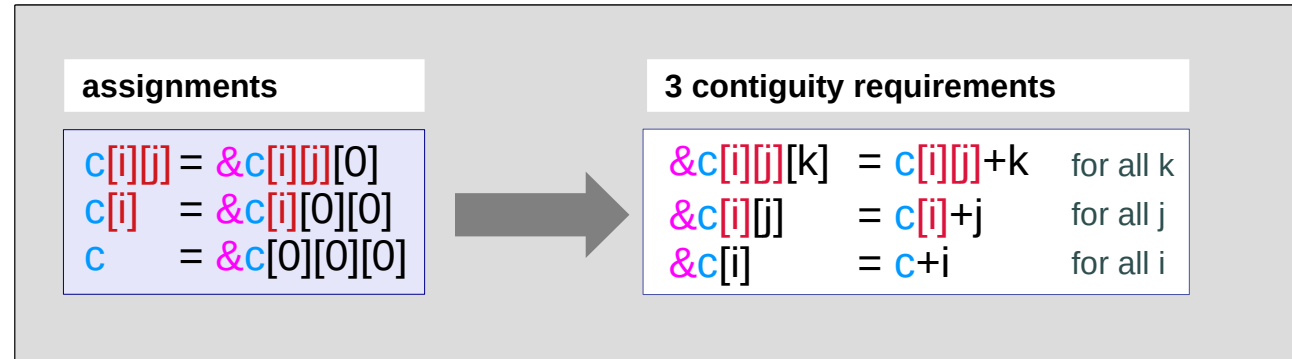

Subarray starting addresses

```
int c [2][3][4];
```

```
&c[i][j][0] = c[i][j]
&c[i][0]    = c[i]
&c[0]      = c
```

with contiguous subarrays

```
&c[i][j][k] = c[i][j]+k for all k
&c[i][j]    = c[i]+j   for all j
&c[i]       = c+i     for all i
```



virtual assignments

```
c[i][j] = &c[i][j][0]
c[i]    = &c[i][0][0]
c       = &c[0][0][0]
```

Array pointer relationships

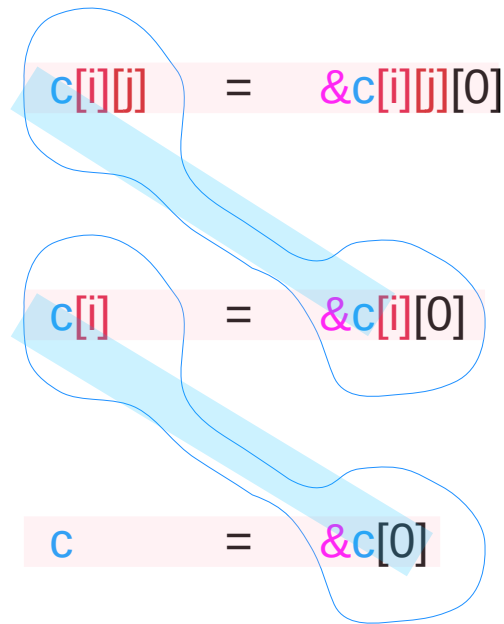

Dual type constraints

$\&c[i][0] = c[i][0]$

$\&c[0] = c[0]$

Subarray starting addresses

```
int c [2][3][4];
```

```
&c[i][j][0] = c[i][j]
&c[i][0]    = c[i]
&c[0]      = c
```

with contiguous subarrays

```
&c[i][j][k] = c[i][j]+k for all k
&c[i][j]    = c[i]+j   for all j
&c[i]       = c+i      for all i
```



virtual assignments

```
c[i][j] = &c[i][j][0]
c[i]    = &c[i][0][0]
c       = &c[0][0][0]
```

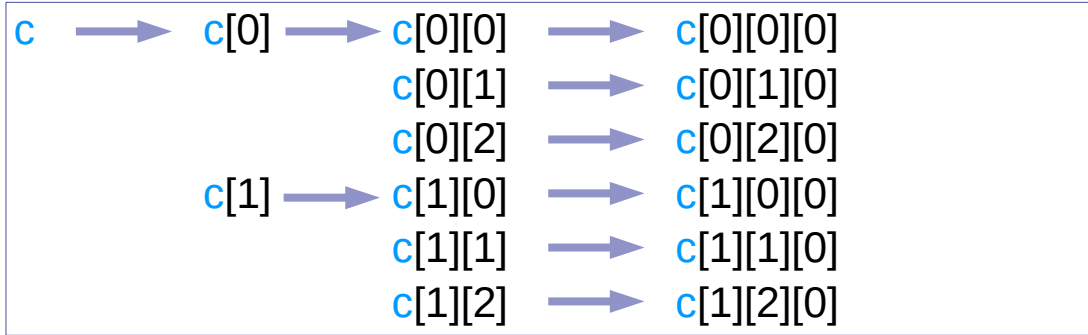

	$c[i][j]$	=	$\&c[i][j][0]$
<i>contiguity</i>	$c[0][0]$	\equiv	$\&c[0][0][0]$
	$c[0][1]$	\equiv	$\&c[0][1][0]$
	$c[0][2]$	\equiv	$\&c[0][2][0]$
	$c[1][0]$	\equiv	$\&c[1][0][0]$
	$c[1][1]$	\equiv	$\&c[1][1][0]$
	$c[1][2]$	\equiv	$\&c[1][2][0]$

	$c[i]$	=	$\&c[i][0]$	=	$\&c[i][0]$	=	$c[i][0]$
<i>contiguity</i>	$c[0]$	\equiv	$\&c[0][0]$	\equiv	$\&c[0][0][0]$		
	$c[1]$	\equiv	$\&c[1][0]$	\equiv	$\&c[1][0][0]$		

dual type constraints

c	=	$\&c[0]$	=	$\&c[0]$	=	$c[0]$
c	\equiv	$\&c[0]$	\equiv	$\&c[0][0]$	\equiv	$\&c[0][0][0]$

dual type constraints

contiguity

Contiguity constraints in a multi-dimensional array

Array pointers and dual types

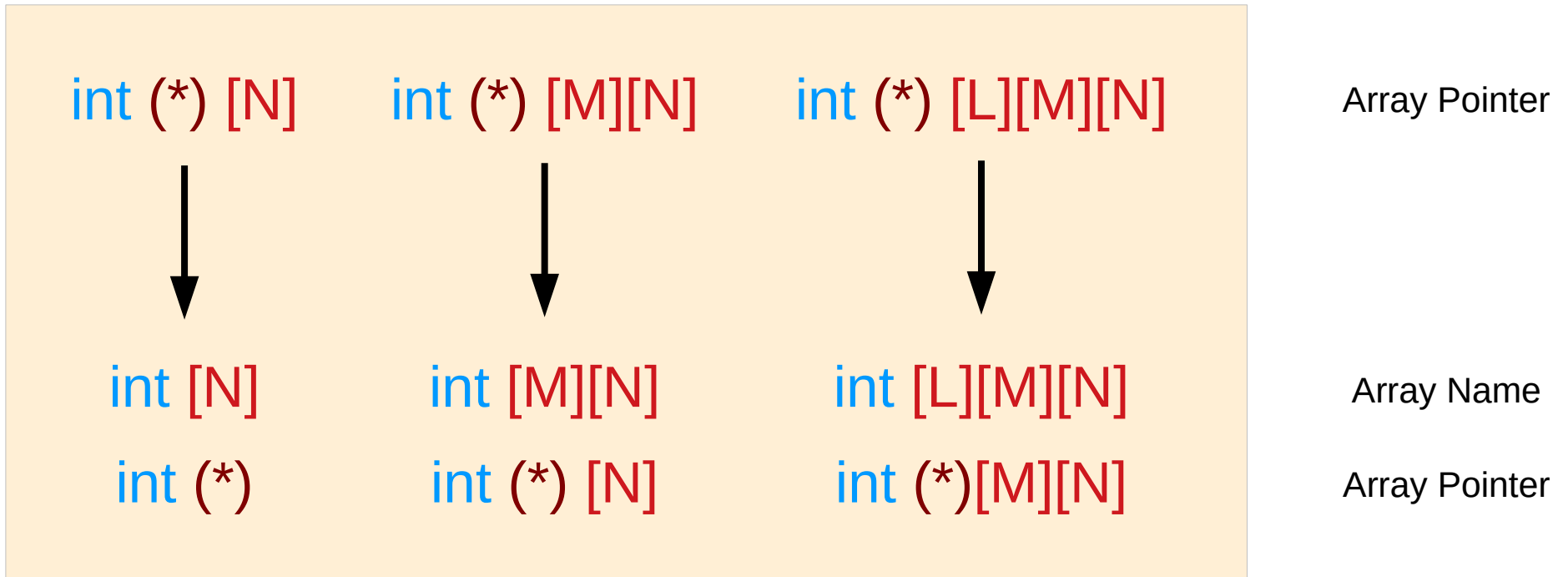

Array pointer approach – contiguity constraints

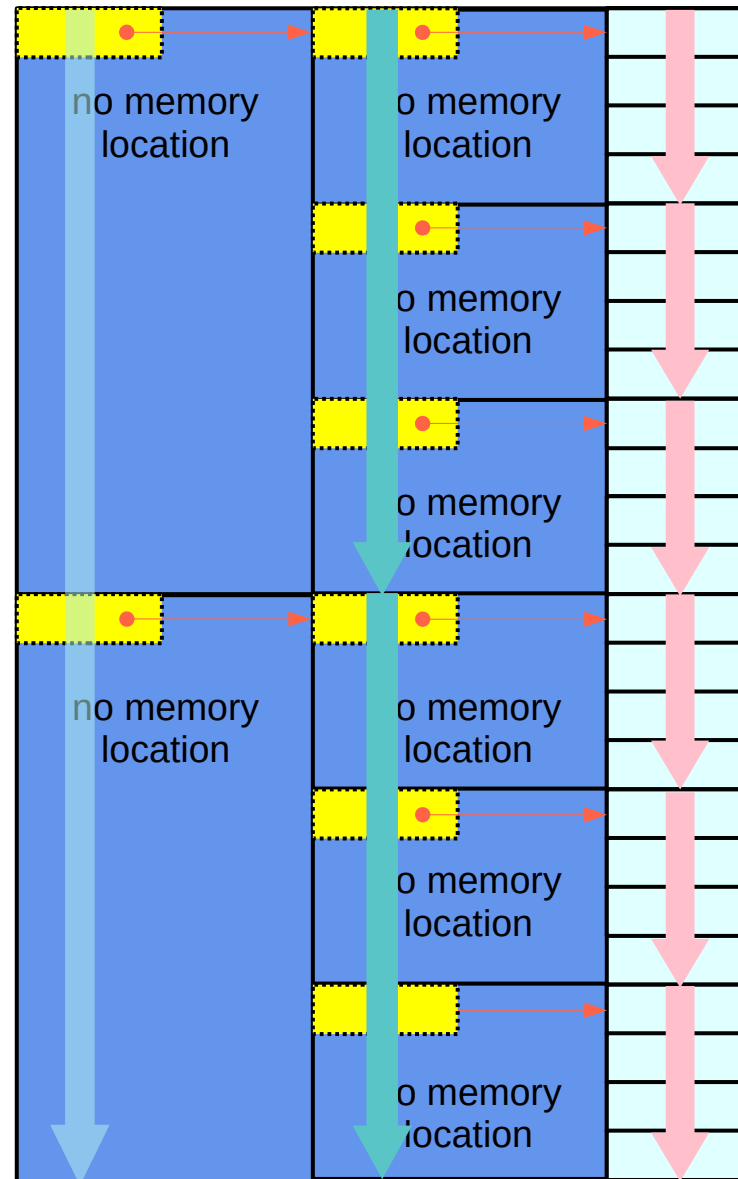

Array **Pointer** Approach
(**pointer to arrays**)

Equivalence and contiguity (1)

consecutive address

$*(X+n)$

consecutive data

$\equiv X[n]$

contiguous index : n

int	X[4];	contiguous X[i] for a given X :	primitive types
int *	X[4];	contiguous X[i] for a given X :	pointer types
atype	X[4];	contiguous X[i] for a given X :	abstract data types

Equivalence and contiguity (2)

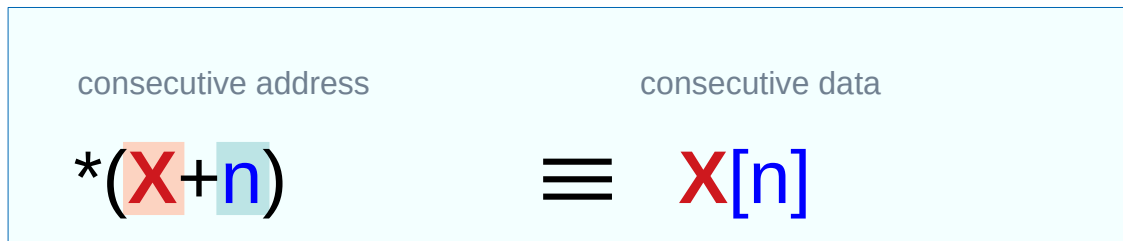

contiguous index : n

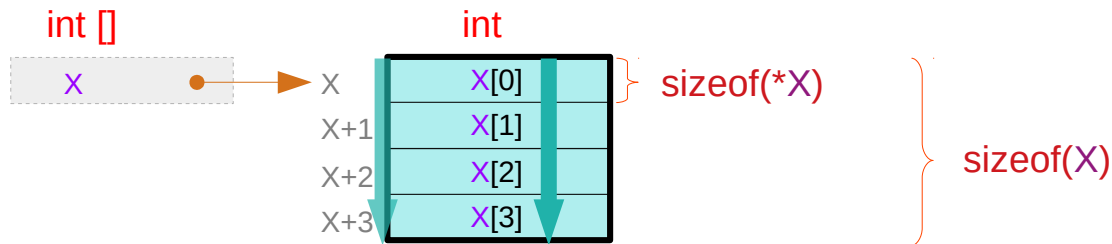

int X[4]; contiguous X[i] for a given X : **primitive types**

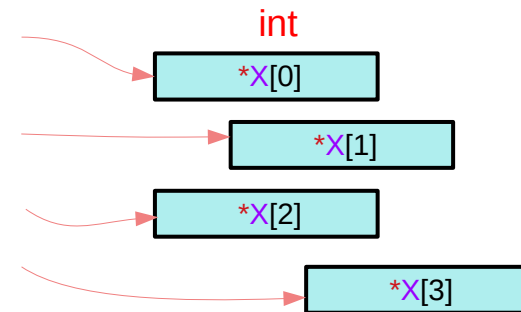
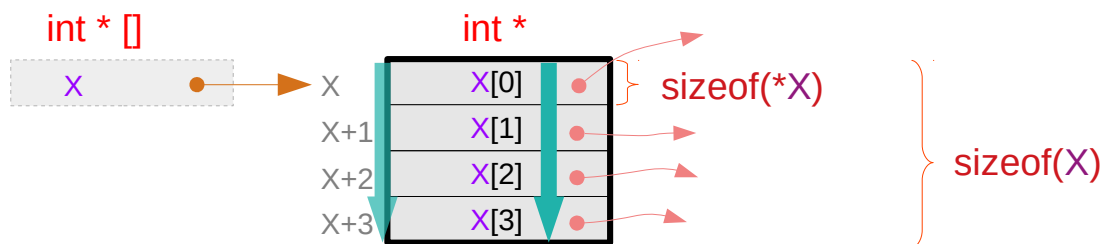

int * X[4]; contiguous X[i] for a given X : **pointer types**

Equivalence and contiguity (3)

consecutive address

$*(X+n)$

consecutive data

$\equiv X[n]$

contiguous index : n

can be recursively applied

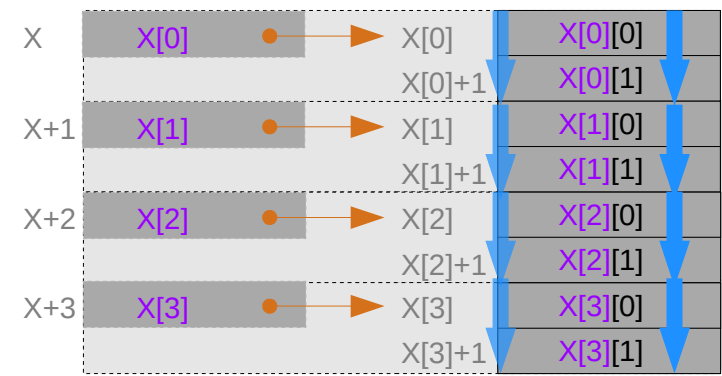
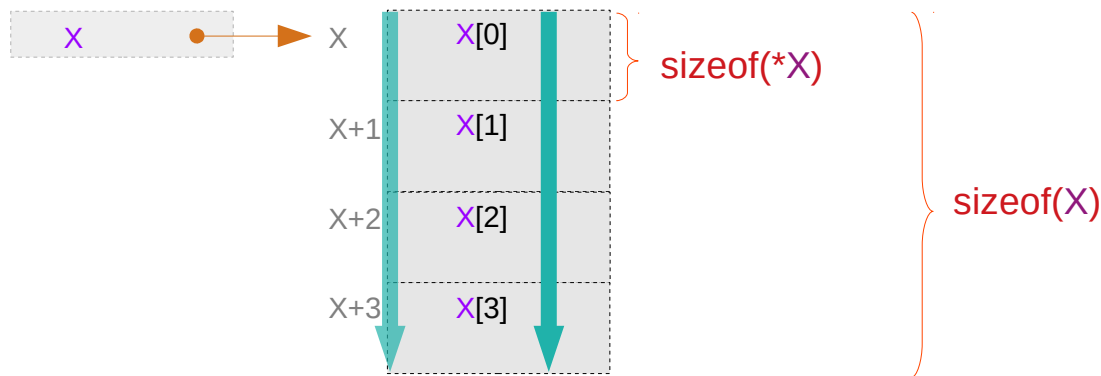

atype $X[4]$; contiguous $X[i]$ for a given X : abstract data types

Recursive applications of equivalences

By definition, contiguous memory locations are assumed

consecutive address		consecutive data
$*(X+n)$	\equiv	$X[n]$

contiguous index : n

$*(p[m]+n)$	\leftrightarrow	$p[m][n]$
$(*(p+m))[n];$	\leftrightarrow	$p[m][n];$

$X = p[m]$ contiguous index : n

$X = p$ contiguous index : m

Equivalence and contiguity (1)

consecutive address

$*(X+n)$

consecutive data

$\equiv X[n]$

contiguous index : n

$*(p[m]+n)$



$p[m][n]$

for a given $p[m]$ contiguous index : n

int $p[M][4];$ contiguous $p[m][i]$ for a given $p[m]$: **primitive types**

int * $p[M][4];$ contiguous $p[m][i]$ for a given $p[m]$: **pointer types**

atype $p[M][4];$ contiguous $p[m][i]$ for a given $p[m]$: **abstract data types**

Equivalence for a given p[m] (2)

$$*(p[m]+n) \iff p[m][n]$$

for a given `p[m]` contiguous index : `n`

`int p[M][4];` contiguous `p[m][n]` for a given `p[m]` : **primitive types**

`m = 0, 1, ..., M-1`

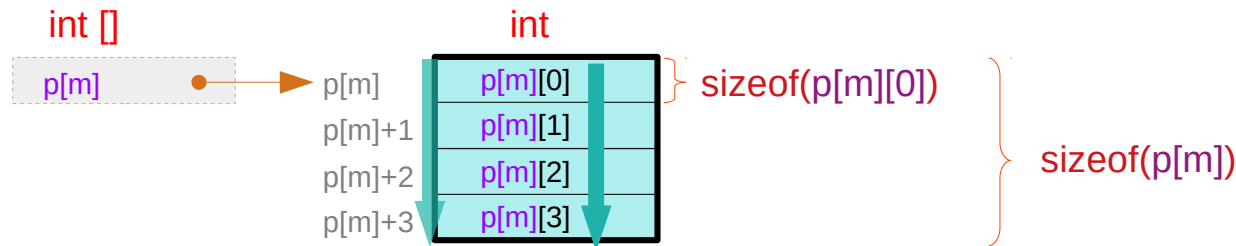

`int * p[M][4];` contiguous `p[m][n]` for a given `p[m]` : **pointer types**

`m = 0, 1, ..., M-1`

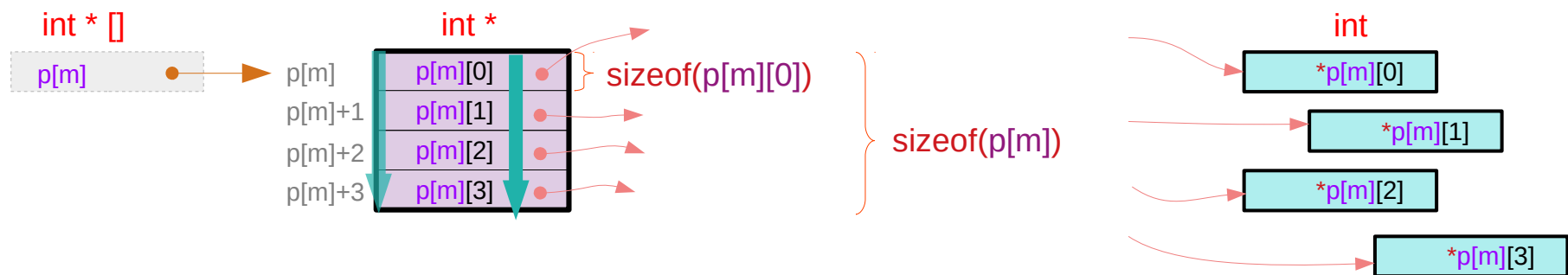

Equivalence for a given $p[m]$ (3)

$$*(p[m]+n) \iff p[m][n]$$

for a given $p[m]$ contiguous index : n

atype $p[M][4]$; contiguous $p[m][n]$ for a given $p[m]$: **abstract data types** $m = 0, 1, \dots, M-1$

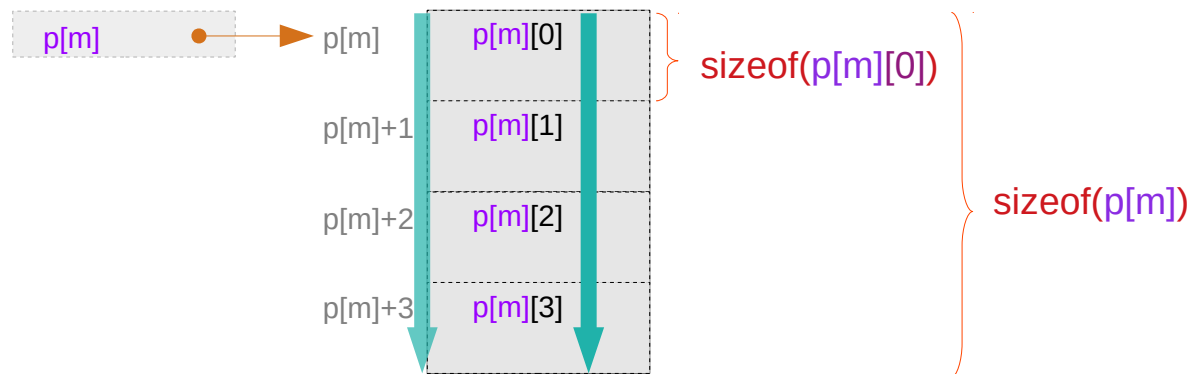

can be recursively applied

Equivalence for a given p[m][n]

$$*(p[m][n]+k) \iff p[m][n][k]$$

for a given `p[m][n]` contiguous index : `k`

`atype * p[M][4][2];` contiguous `p[m][n][k]` for a given `p[m][n]` : **abstract data types** `m = 0, 1, ..., M-1`

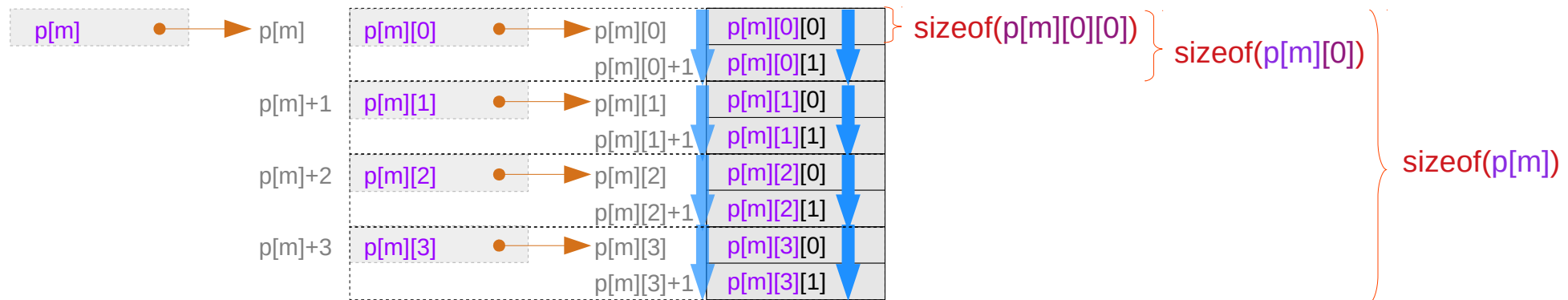

Contiguity constraints in multi-dimensional arrays

$$*(p[m]+n) \iff p[m][n]$$

for a given $p[m]$, thus for a given p and m ,
 $p[m][n]$'s must be contiguous for all n .
 $p[m][0], p[m][1], \dots, p[m][N-1]$

contiguous index : n

$$*(p+m) \iff p[m]$$

for a given p ,
 $p[m]$'s must be contiguous for all m .
 $p[0], p[1], \dots, p[M-1]$

contiguous index : m

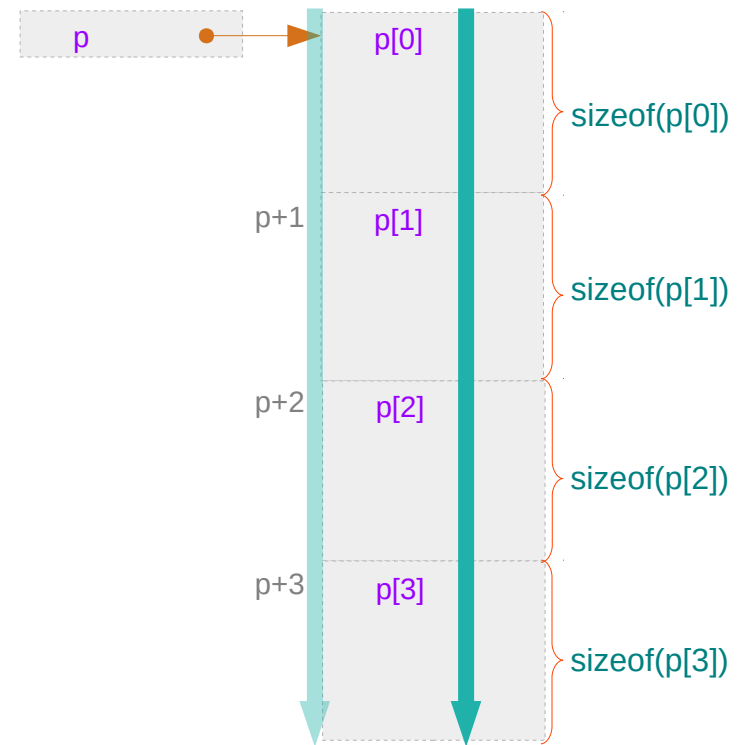
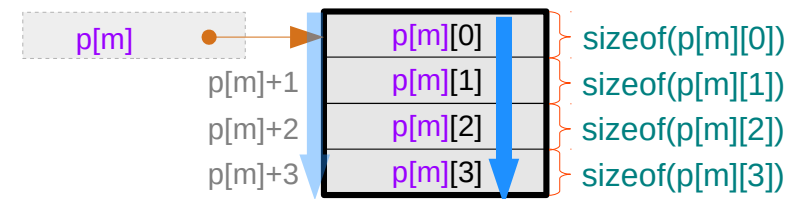

Contiguity constraints for p

$$*(p+m) \iff p[m]$$

for a given p contiguous index : m

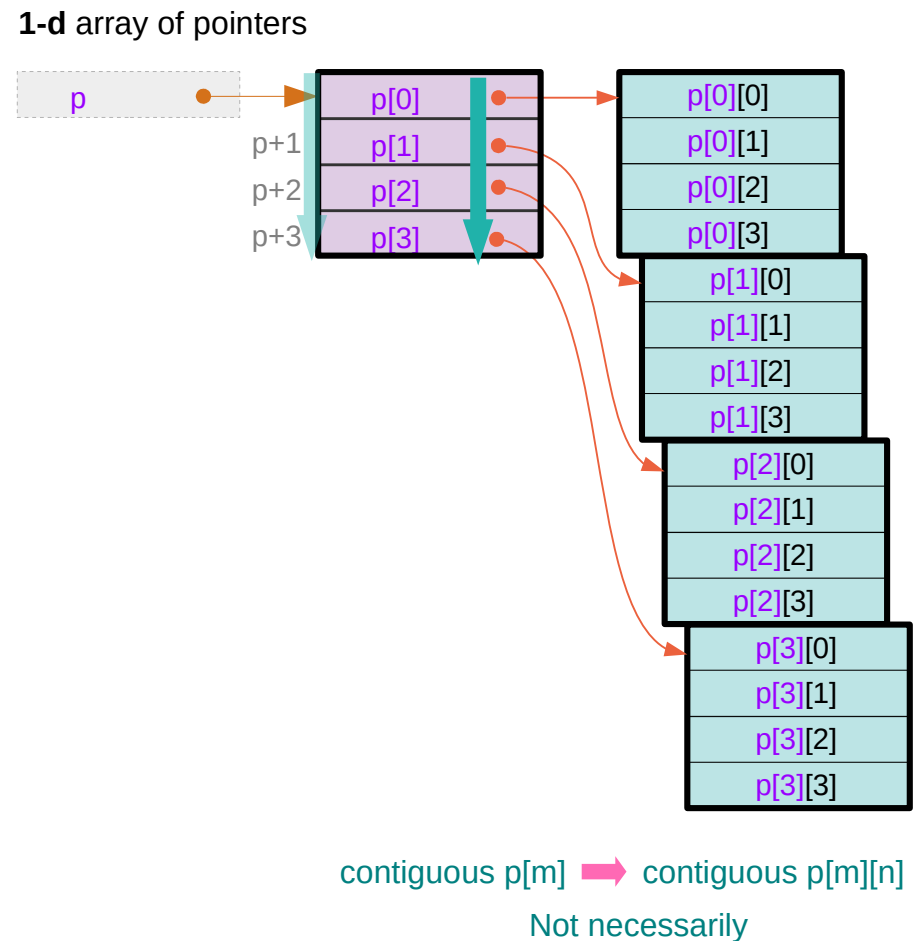
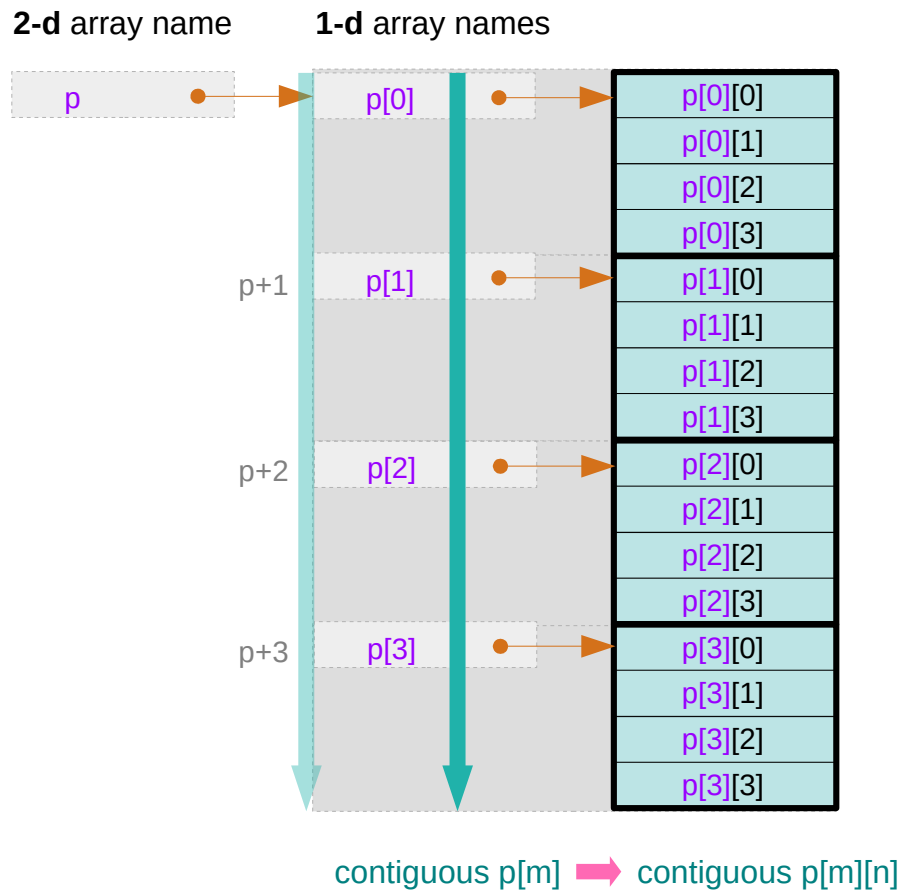

Contiguity constraints for p[m] – using array pointers

$$*(p[m]+n) \iff p[m][n]$$

for a given $p[m]$ contiguous index : n

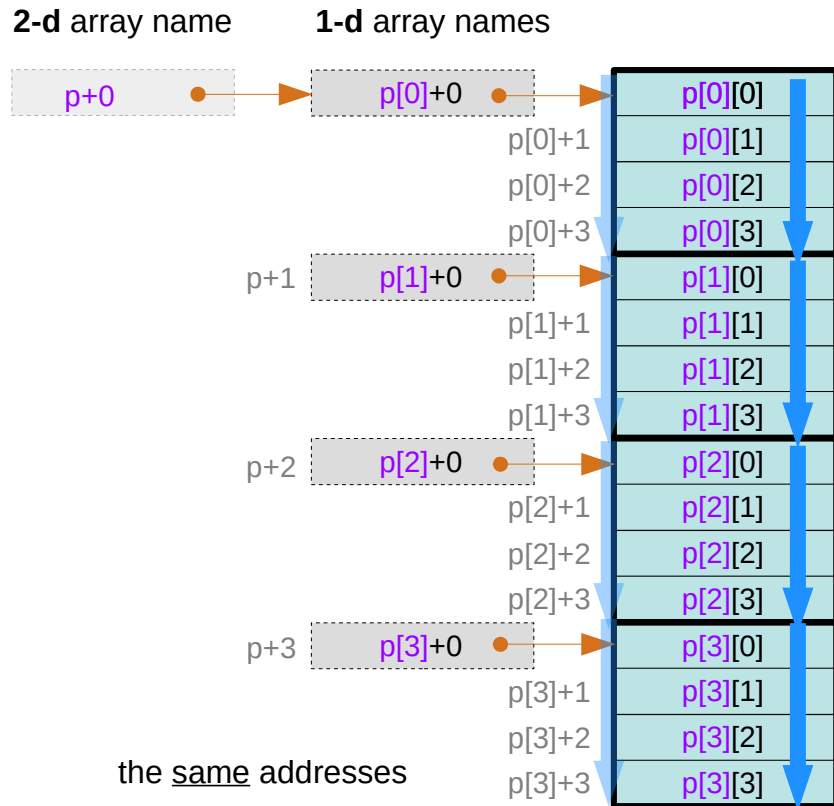

$$p[0][0] = *(p[0]+0) \xrightarrow{\text{addr}} \underbrace{\&p[0][0] = p[0]}_{\text{addr}} \xrightarrow{\text{addr}} p+0$$

$$p[1][0] = *(p[1]+0) \xrightarrow{\text{addr}} \underbrace{\&p[1][0] = p[1]}_{\text{addr}} \xrightarrow{\text{addr}} p+1$$

$$p[2][0] = *(p[2]+0) \xrightarrow{\text{addr}} \underbrace{\&p[2][0] = p[2]}_{\text{addr}} \xrightarrow{\text{addr}} p+2$$

$$p[3][0] = *(p[3]+0) \xrightarrow{\text{addr}} \underbrace{\&p[3][0] = p[3]}_{\text{addr}} \xrightarrow{\text{addr}} p+3$$

the same addresses

contiguous $p[m]$ \rightarrow contiguous $p[m][n]$

virtual array pointer \iff no real memory locations

Contiguity constraints for p[m] – using pointer arrays

$$*(p[m]+n) \iff p[m][n]$$

for a given $p[m]$ contiguous index : n

1-d array of pointers

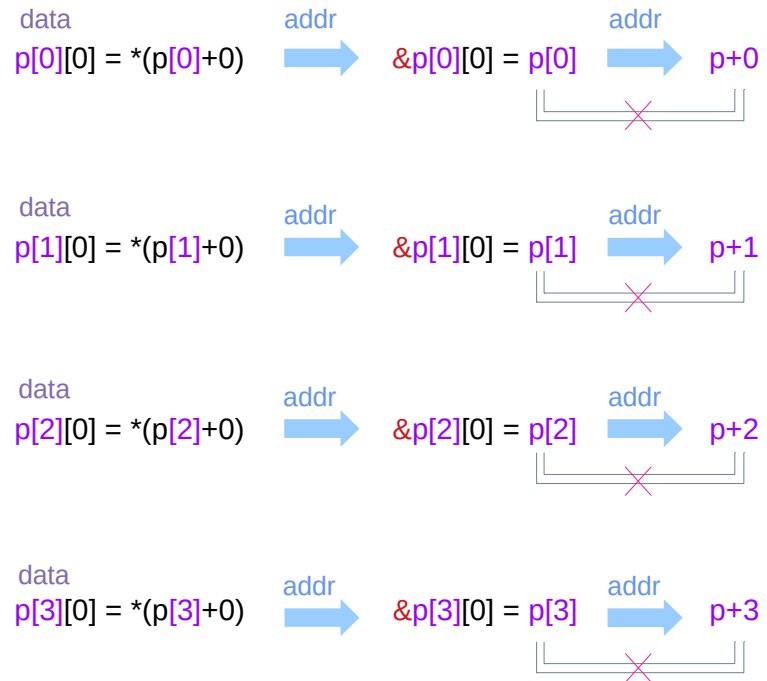
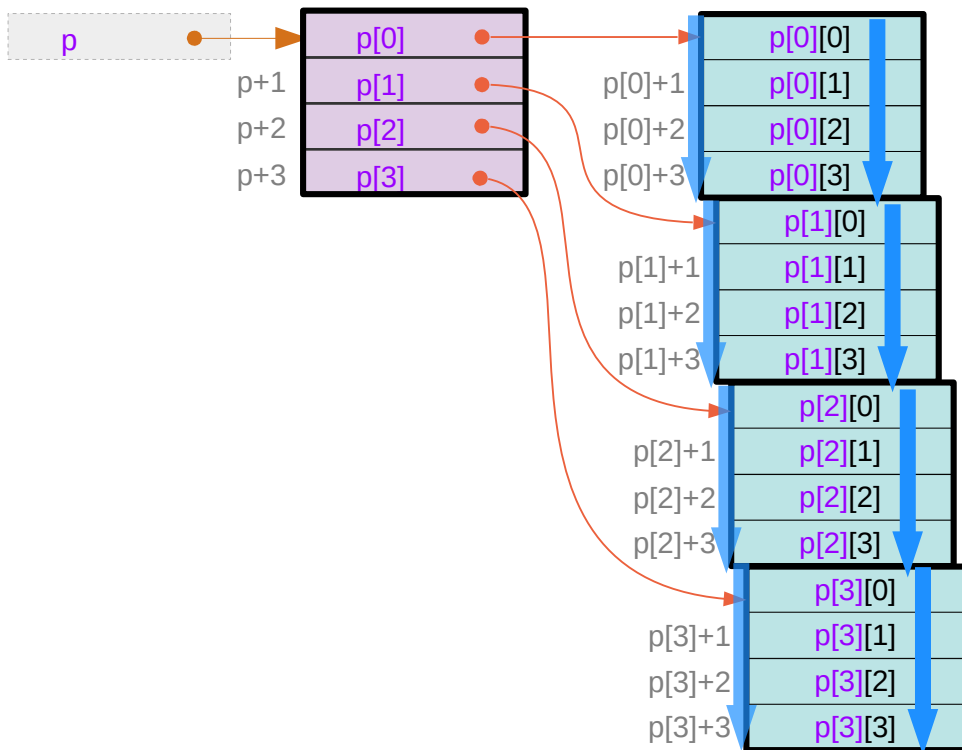

the different addresses

contiguous $p[m]$ \rightarrow contiguous $p[m][n]$
Not necessarily

Contiguity constraints for 2-d arrays

```
int a[M][N] ;
```

$*(a+m) \leftrightarrow a[m]$

$a[0], a[1], \dots, a[M-1]$
are contiguous

$*(a[m]+n) \leftrightarrow a[m][n]$

$a[m][0], a[m][1], \dots, a[m][N-1]$
are contiguous

```
int (*b)[N] ;
```

$*(b+m) \leftrightarrow b[m]$

$b[0], b[1], \dots, b[M-1]$
are contiguous

$*(b[m]+n) \leftrightarrow b[m][n]$

$b[m][0], b[m][1], \dots, b[m][N-1]$
are contiguous

```
int * c[M] ;
```

$*(c+m) \leftrightarrow c[m]$

$c[0], c[1], \dots, c[M-1]$
are contiguous

$*(c[m]+n) \leftrightarrow c[m][n]$

$c[m][0], c[m][1], \dots, c[m][N-1]$
are contiguous

a set of assignments of pointers
are necessary for this contiguity

Pointer Arrays vs Array Pointers

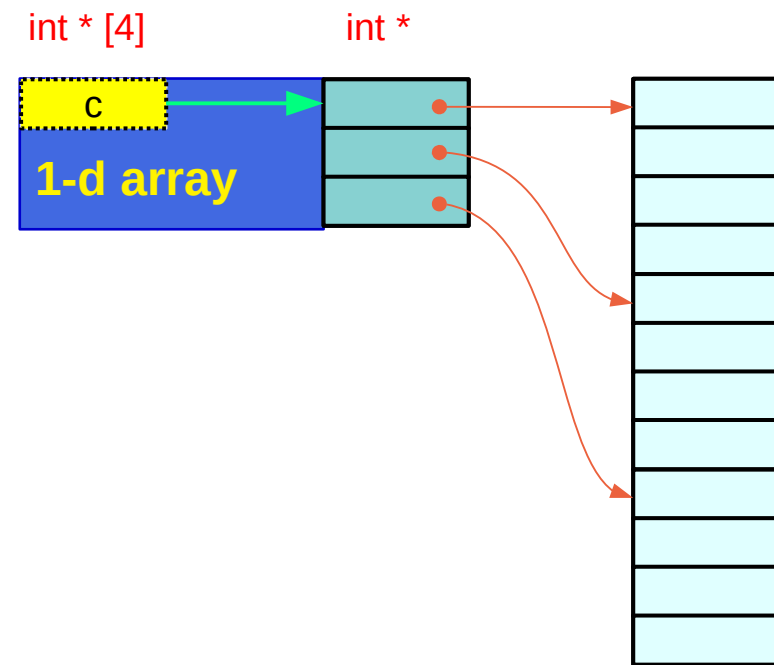
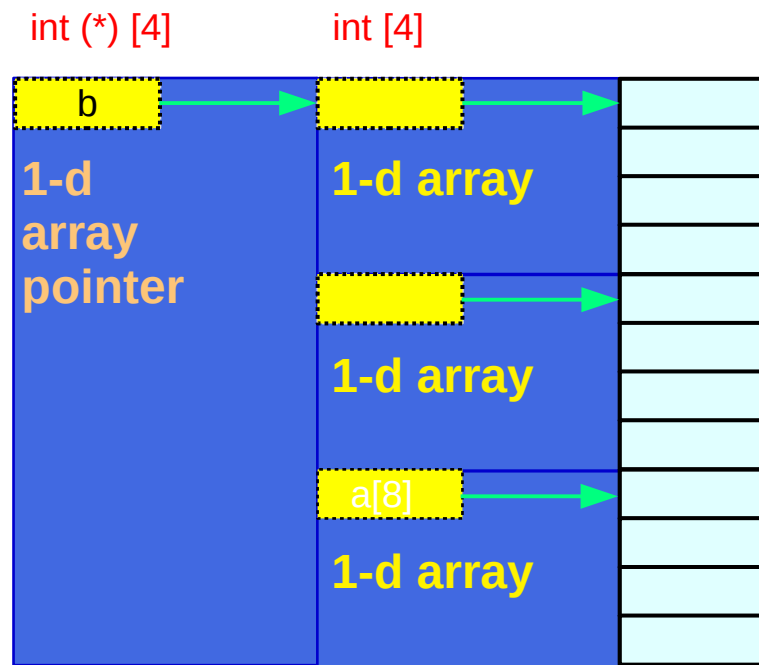

`int (*b)[N] ;`

`*(b+m)` \longleftrightarrow `b[m]`
`*(b[m]+n)` \longleftrightarrow `b[m][n]`

`int * c[M] ;` with proper assignments

`*(c+m)` \longleftrightarrow `c[m]` or
`*(c[m]+n)` \longleftrightarrow `c[m][n]`

Pointer Arrays vs Array Pointers

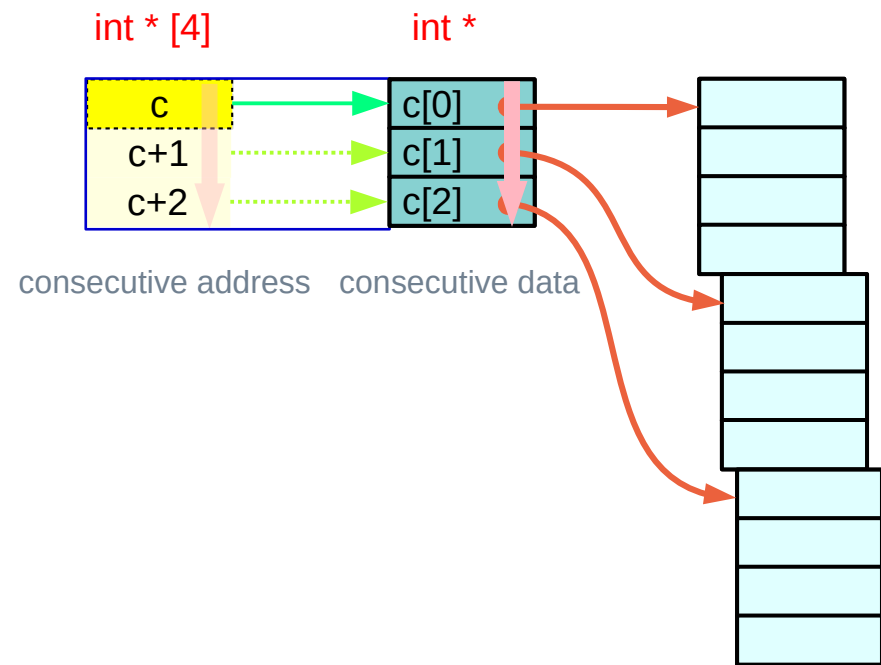
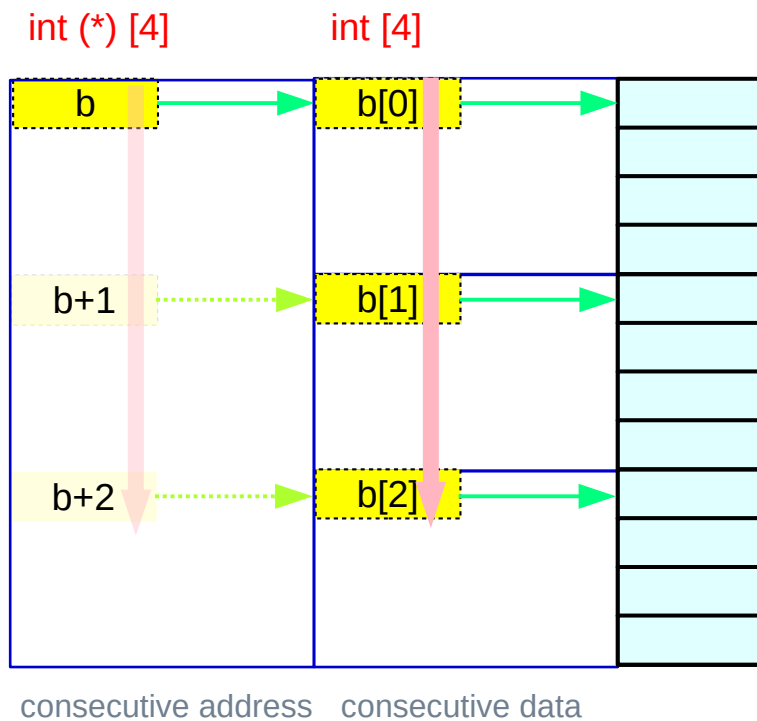

`int (*b)[N] ;`

`*(b+m)` \longleftrightarrow `b[m]`
`*(b[m]+n)` \longleftrightarrow `b[m][n]`

`int * c[M] ;`

with proper assignments

`*(c+m)` \longleftrightarrow `c[m]` or
`*(c[m]+n)` \longleftrightarrow `c[m][n]`

Pointer Arrays vs Array Pointers

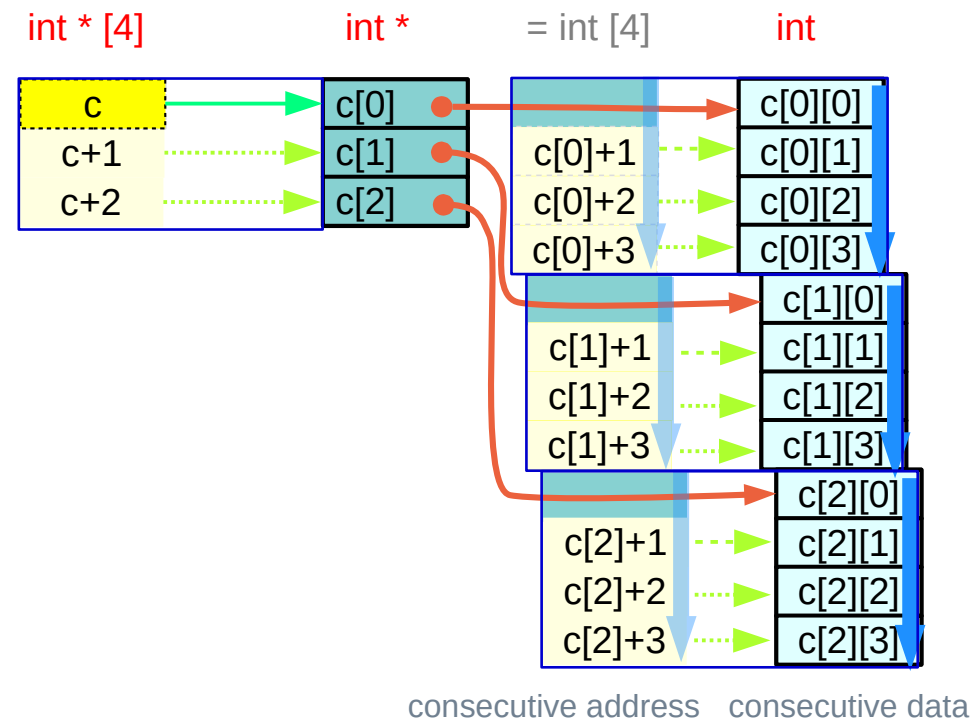
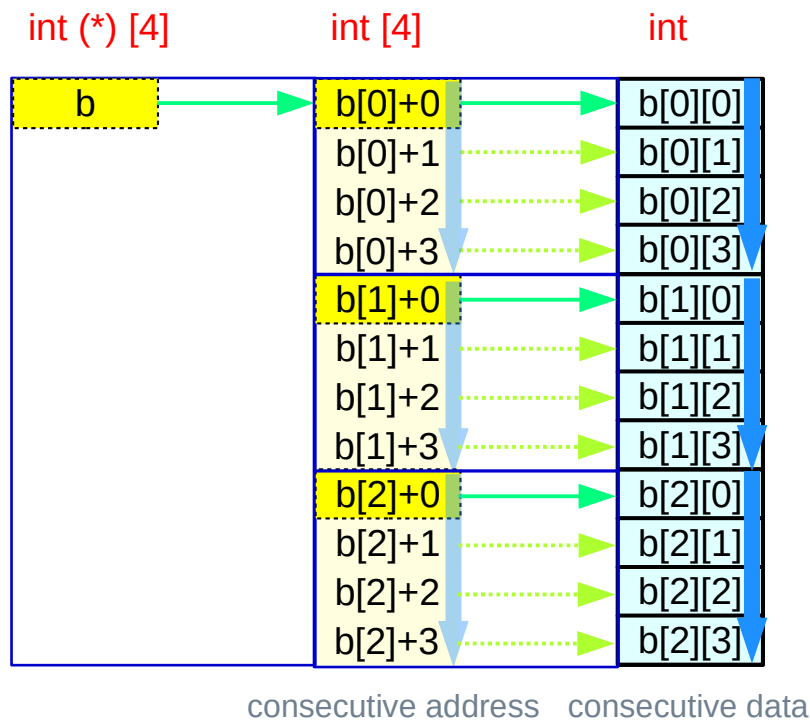

```
int (*b)[N] ;
```

```
int * c[M] ;      with proper assignments
```

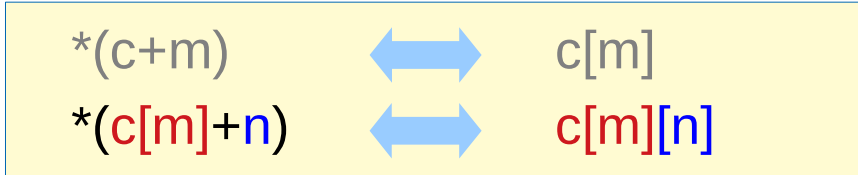
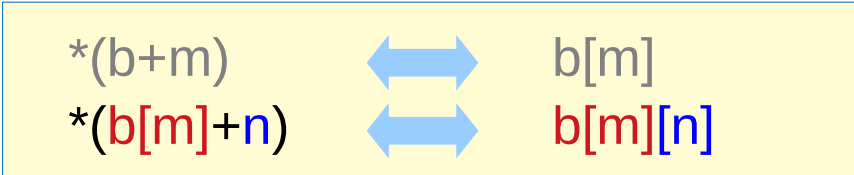

Three contiguity constraints for 3-d arrays

Pointer Array Approach (array of pointers)

<code>c[i][j][k]</code>	→	<code>*(c[i][j] + k)</code>
<code>*(c[i][j] + k)</code>	→	<code>*(*(c[i] + j) + k)</code>
<code>*(*(c[i] + j) + k)</code>	→	<code>*(***(c + i) + j) + k)</code>

contiguous int	<code>int</code>
contiguous pointers to int	<code>int *</code>
contiguous double pointers to int	<code>int **</code>

the contiguity constraints are satisfied by allocating arrays of pointers

Array Pointer Approach (pointer to arrays)

<code>c[i][j][k]</code>	→	<code>*(c[i][j] + k)</code>
<code>*(c[i][j] + k)</code>	→	<code>*(*(c[i] + j) + k)</code>
<code>*(*(c[i] + j) + k)</code>	→	<code>*(***(c + i) + j) + k)</code>

contiguous 0-d arrays	<code>int</code>	<code>int</code>
contiguous 1-d arrays	<code>int [4]</code>	<code>int *</code>
contiguous 2-d arrays	<code>int [3][4]</code>	<code>int (*) [4]</code>

The contiguity constraints are satisfied by row major ordered linear data layout

Contiguous array pointers $c[i][j][k] \equiv *(c[i][j] + k)$

```

c[0][0][0] = *(c[0][0] + 0)
c[0][0][1] = *(c[0][0] + 1)
c[0][0][2] = *(c[0][0] + 2)
c[0][0][3] = *(c[0][0] + 3)
c[0][1][0] = *(c[0][1] + 0)
c[0][1][1] = *(c[0][1] + 1)
c[0][1][2] = *(c[0][1] + 2)
c[0][1][3] = *(c[0][1] + 3)

```

• •
• •

contiguous 1-d
array elements

c[i][j]
int [4] 4 contiguous 0-d arrays
int * points to the 1st 0-d array
int 0-d array

`sizeof(c[i][j])` [k]
`sizeof(c[i][j][k]) * 4`
`sizeof(int) * 4`

```
int c[2][3][4];
```

Address Value
`c[i][j] + k`
`&c[i][j][0] + k * sizeof(*c[i][j])`
`&c[i][j][0] + k * sizeof(c[i][j][0])`
`&c[i][j][0] + k * 4`

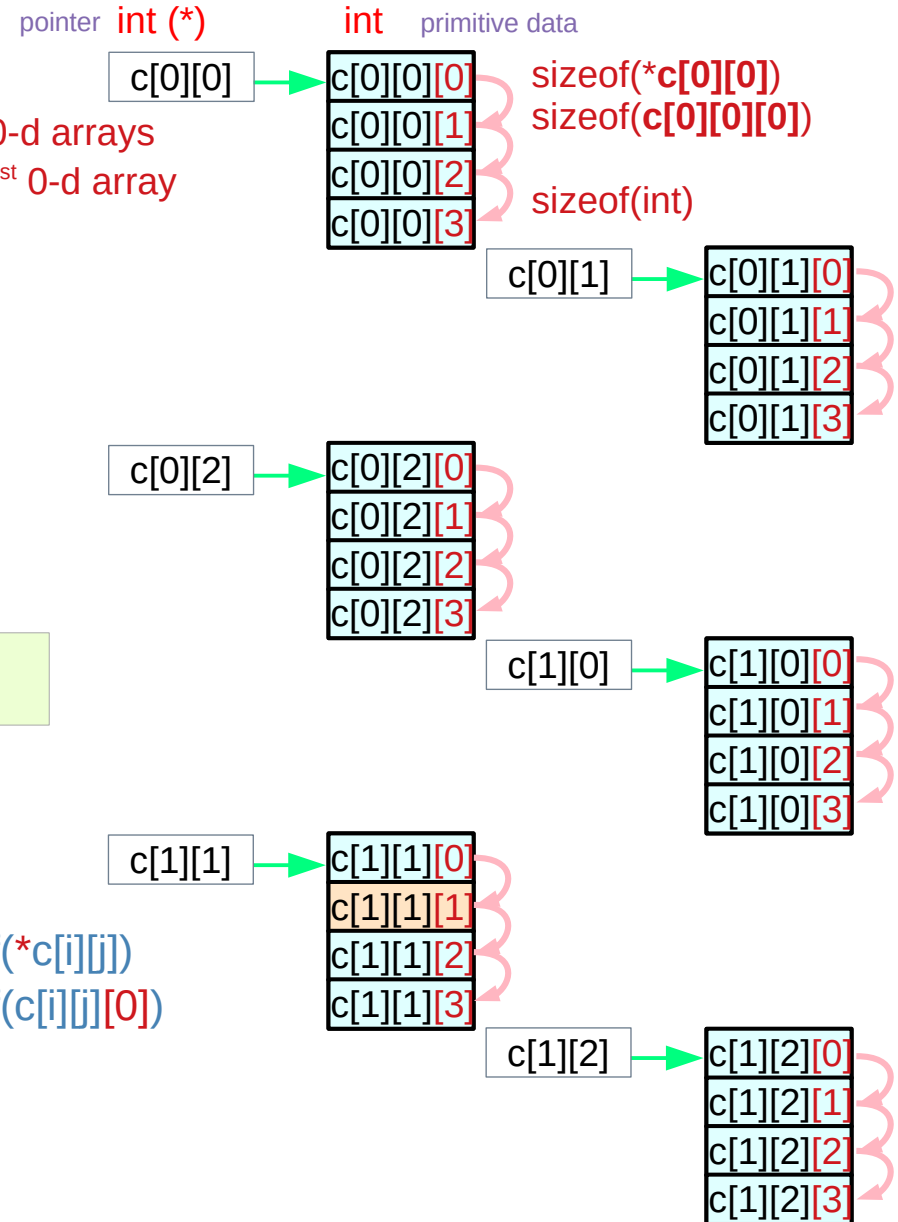

Contiguous array pointers $c[i][j] \equiv *(c[i] + j)$

```

c[0][0] = *(c[0] + 0)
c[0][1] = *(c[0] + 1)
c[0][2] = *(c[0] + 2)
c[1][0] = *(c[1] + 0)
c[1][1] = *(c[1] + 1)
c[1][2] = *(c[1] + 2)
    
```

c[i]
int [3][4] 3 contiguous 1-d arrays
int (*) [4] points to the 1st 1-d array
int [4] 1-d array

sizeof(c[i]) [j] [k]
 sizeof(c[i][j][k]) * 3 * 4
 sizeof(int) * 3 * 4

```
int c[2][3][4];
```

Address Value

$c[i] + j$

$\&c[i][0][0] + j * \text{sizeof}(*c[i])$

$\&c[i][0][0] + j * \text{sizeof}(c[i][0])$

$\&c[i][0][0] + j * 4 * 4$

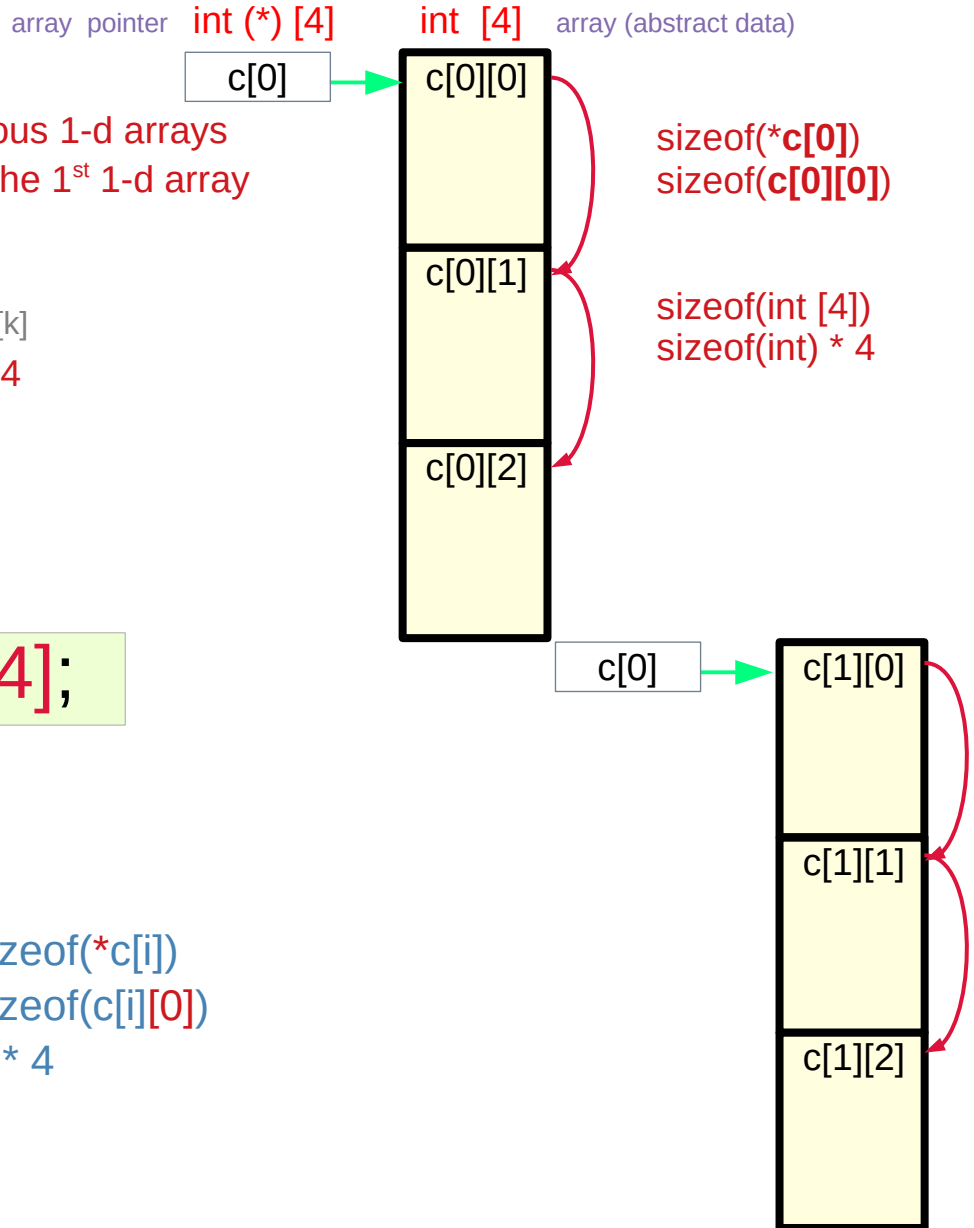

Contiguous array pointers $c[i] \equiv *(c + i)$

```
c[0] = *(c + 0)
c[1] = *(c + 1)
```

```
c
int [2][3][4]
int (*) [3][4]
int [3][4]
```

2 contiguous 2-d arrays
points to the 1st 2-d array
2-d array

```
sizeof(c)           [i] [j] [k]
sizeof(c[i][j][k]) * 2 * 3 * 4
sizeof(int) * 2 * 3 * 4
```

```
int c[2][3][4];
```

Address Value

```
c + i
&c[0][0][0] + i * sizeof(*c)
&c[0][0][0] + i * sizeof(c[0])
&c[0][0][0] + i * 4 * 3 * 4
```

array pointer $int (*) [3][4]$ $int [3][4]$ array (abstract data)

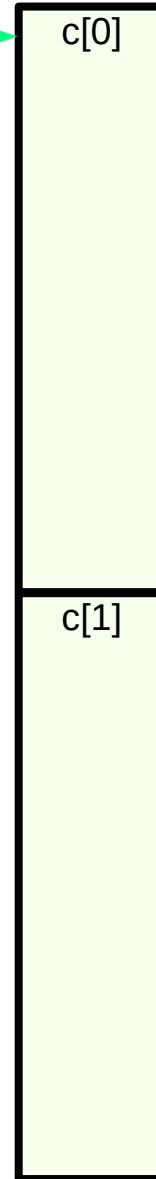

sizeof(*c)
sizeof(c[0])

sizeof(int [3][4])
sizeof(int) * 3 * 4

Contiguous linear layout

```
int c [L][M][N];
```

```
C [i][j][k];
```

L	M	N
i	j	k
$i * M * N$	$j * N$	k

Base Index = 0

Offset Index 1 (i=1)

Offset Index 2 (j=1)

Offset Index 3 (k=1)

$$(i * M * N + j * N + k)$$

$$((i * M + j) * N + k)$$

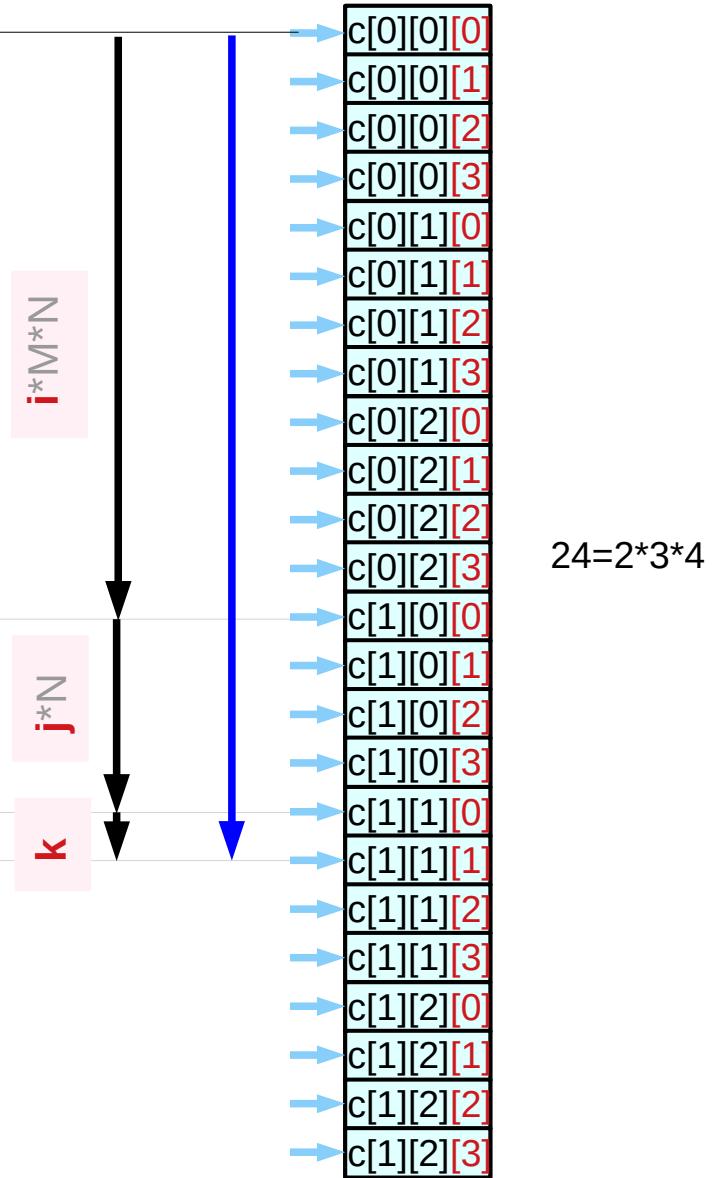

Base and Offset Addressing

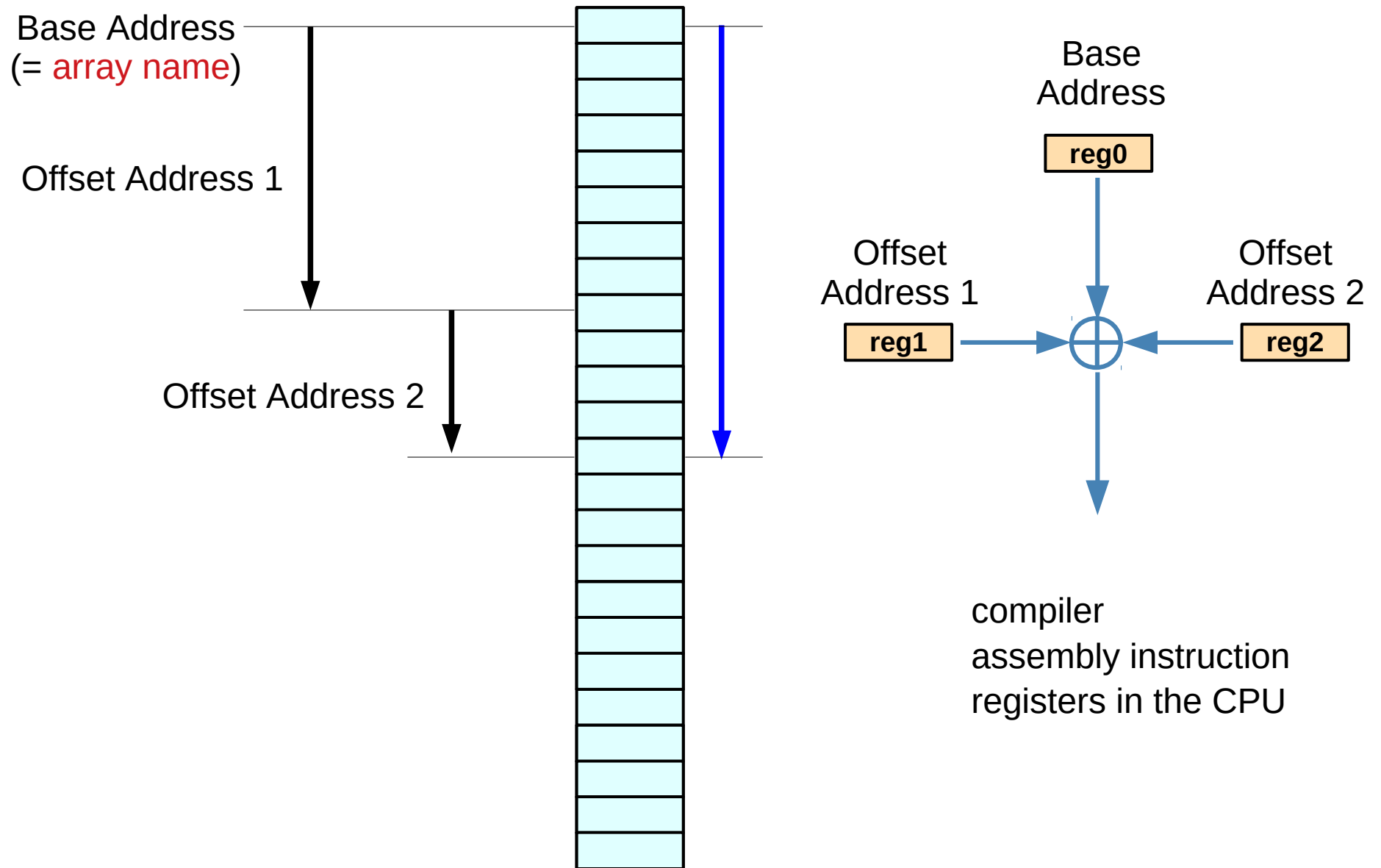

Array Pointer Approach

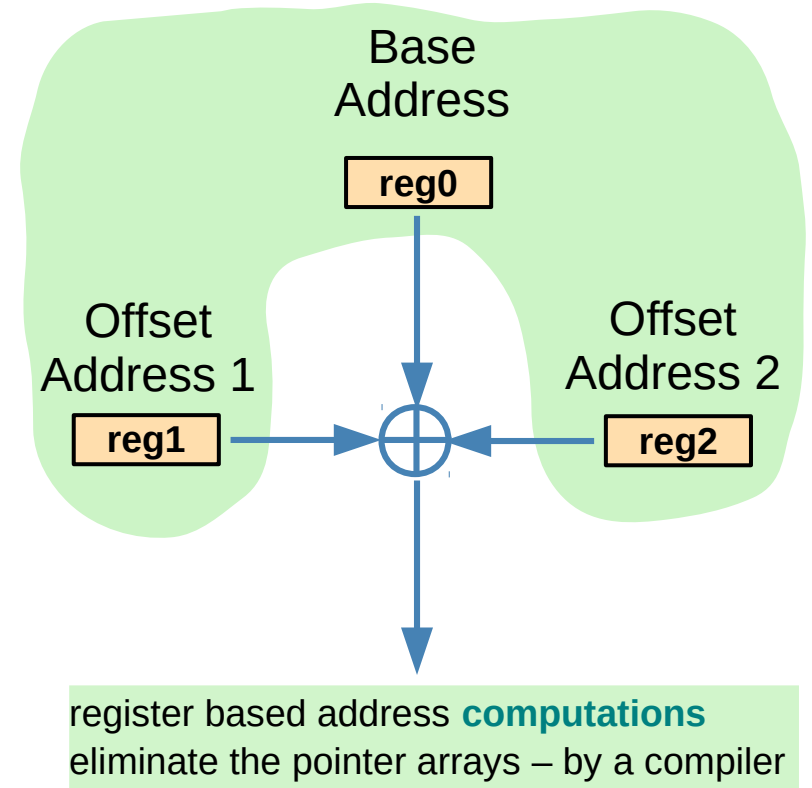
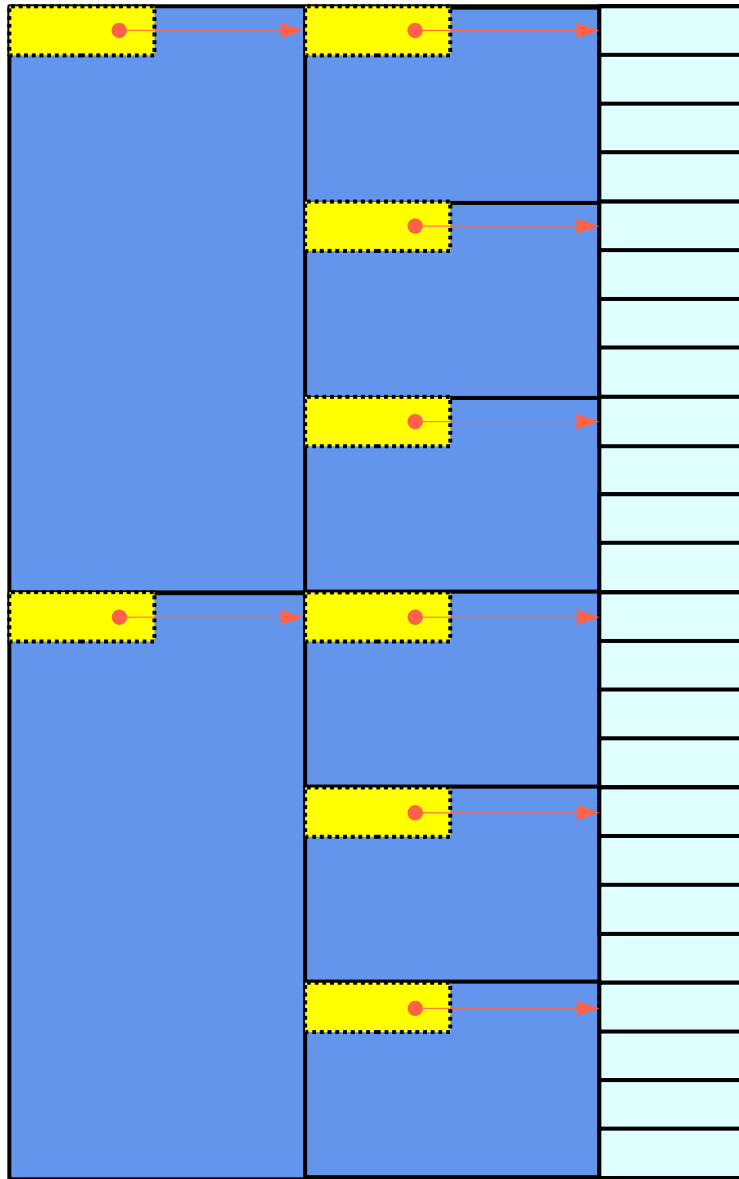

Array Pointer Approach
(pointer to arrays)

References

- [1] Essential C, Nick Parlante
- [2] Efficient C Programming, Mark A. Weiss
- [3] C A Reference Manual, Samuel P. Harbison & Guy L. Steele Jr.
- [4] C Language Express, I. K. Chun