

Capacitor in an AC circuit

Copyright (c) 2011 - 2017 Young W. Lim.

Permission is granted to copy, distribute and/or modify this document under the terms of the GNU Free Documentation License, Version 1.2 or any later version published by the Free Software Foundation; with no Invariant Sections, no Front-Cover Texts, and no Back-Cover Texts. A copy of the license is included in the section entitled "GNU Free Documentation License".

Please send corrections (or suggestions) to youngwlim@hotmail.com.

This document was produced by using OpenOffice and Octave.

Everchanging signal pairs

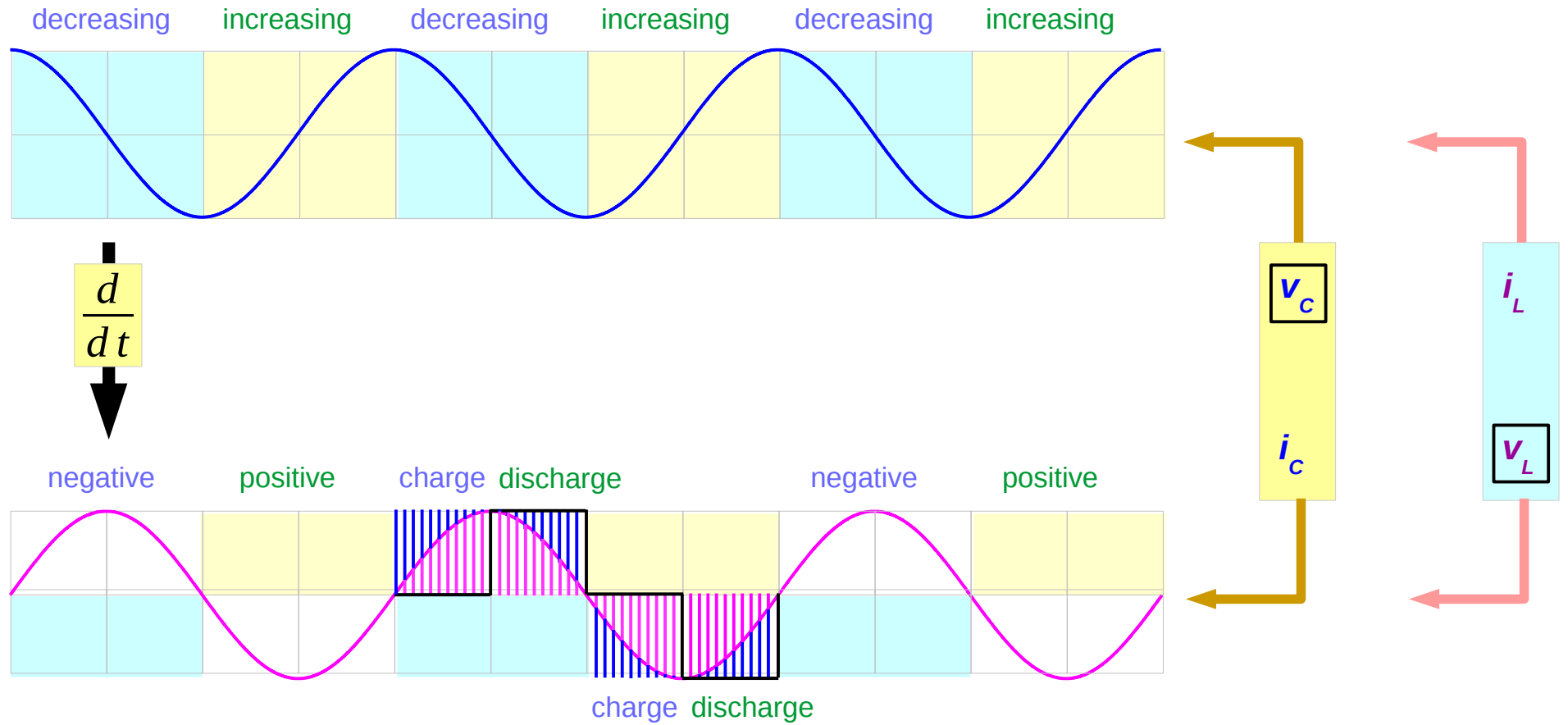

Capacitor Current

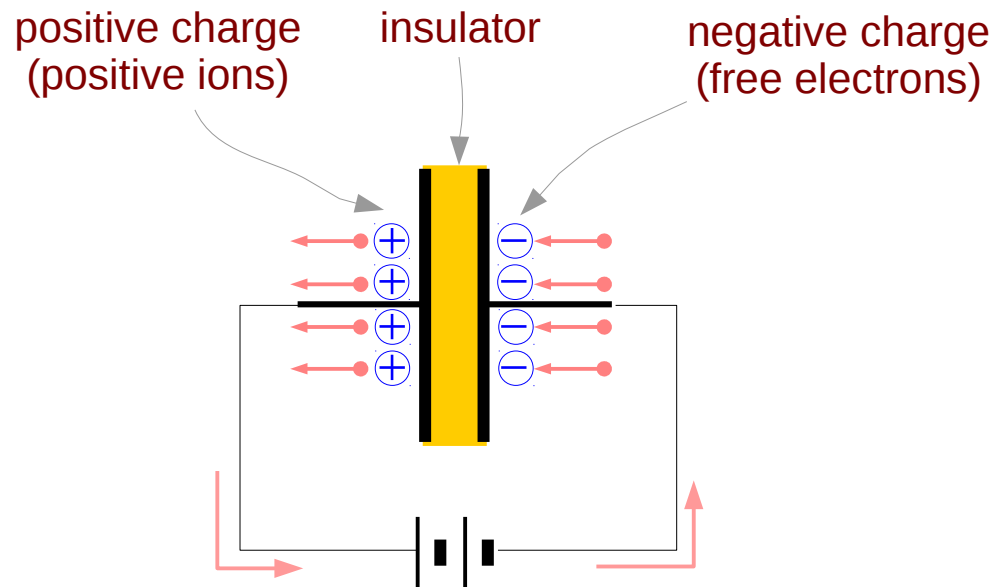

No actual electrons movement across insulator materials



But, think as

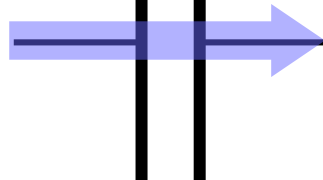

Displacement Current

flows through the capacitor

Positive ions and free electrons

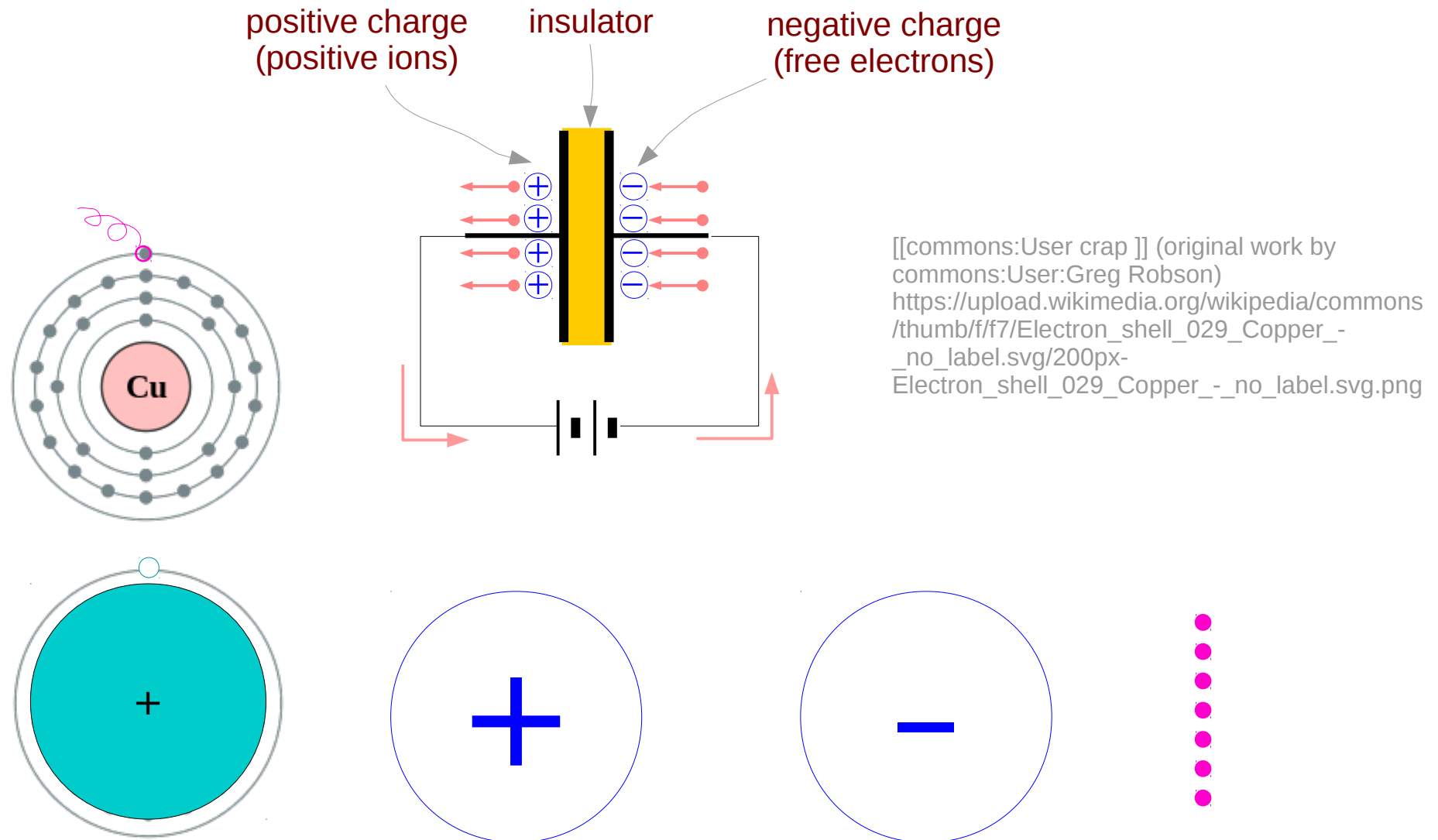

Three States

positive charge
(positive ions)

Positively Charged State

fully charged → no current

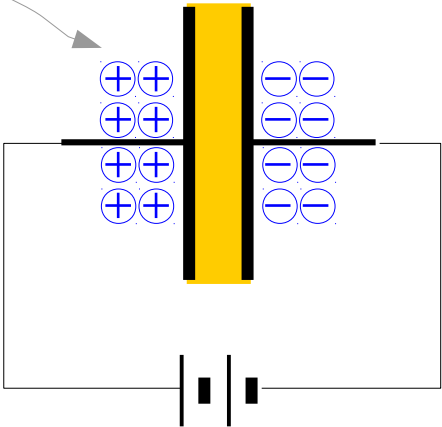

negative charge
(free electrons)

Negatively Charged State

fully charged → no current

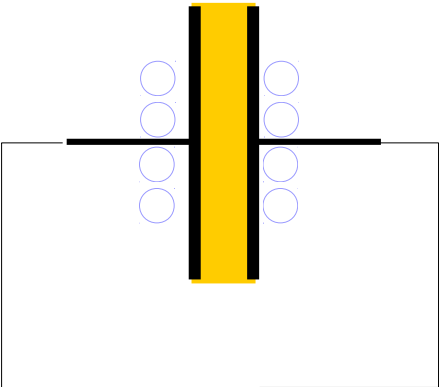
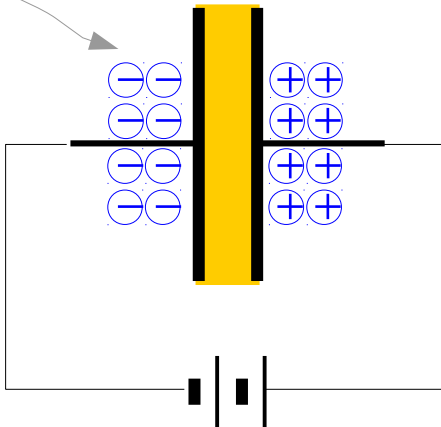

Fully Discharged State

possible large current

Currents in the Fully Discharged State

Initially no current

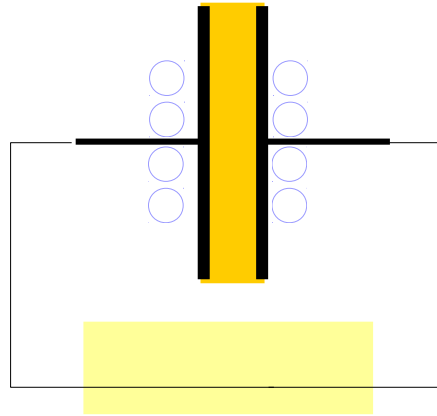

Fully Discharged State

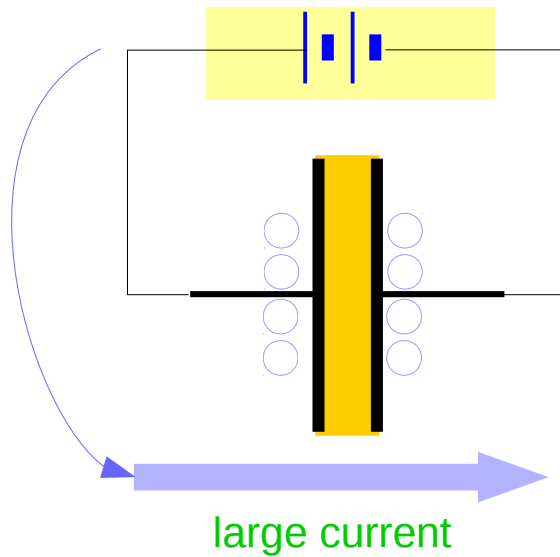

Fully Discharged State

This state can flow large current in either direction

Fully Discharged State

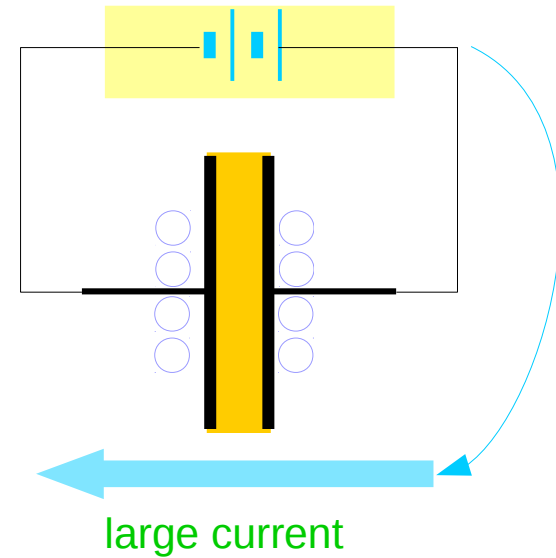

Inter-State Current Flowing

Under Positively Charging

(+) current flow direction

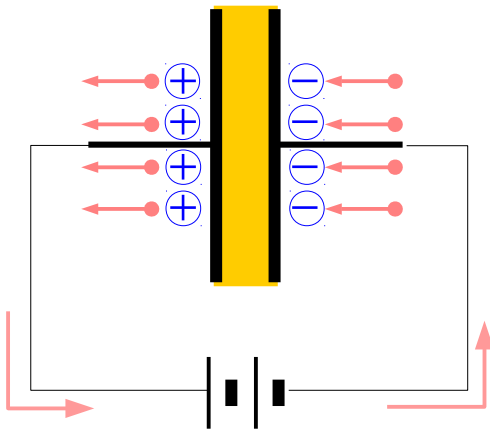

electron flow direction

Under Negatively Charging

(-) current flow direction

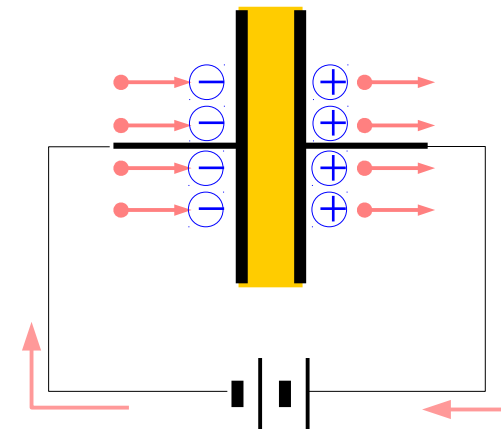
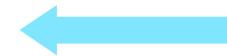

electron flow direction

Inter-State Current Flowing

Fully Discharged State

(+) current flow direction

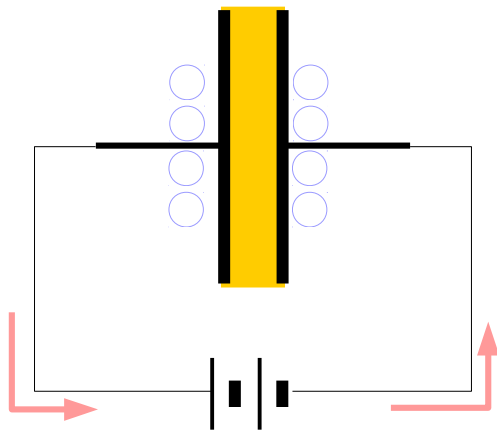

electron flow direction

Initial large current

Under Positively Charging

(+) current flow direction

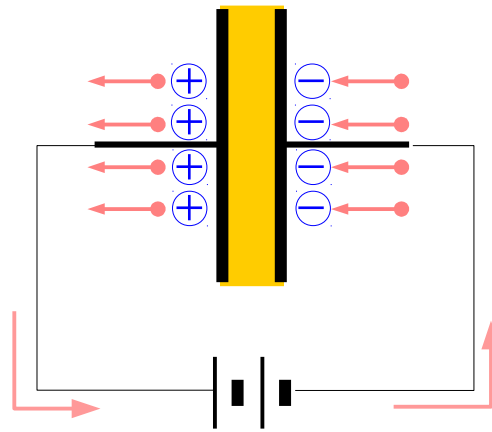

electron flow direction

Positively Charged State

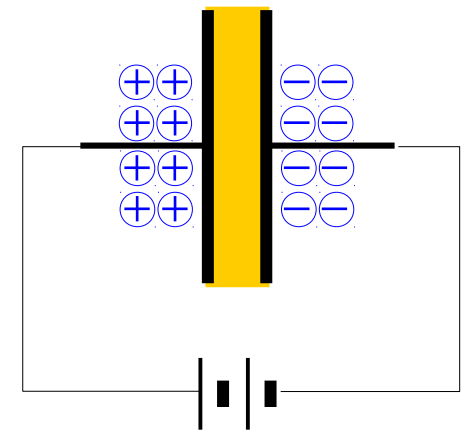

Crowded →
No more space

no current

Inter-State Current Flowing

Fully Discharged State

(-) current flow direction

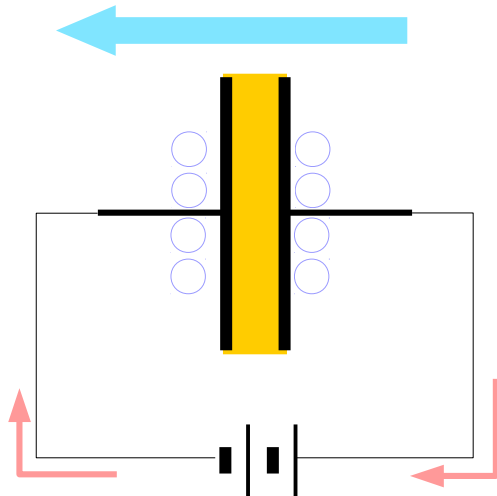

electron flow direction

Initial large current

Under Negatively Charging

(-) current flow direction

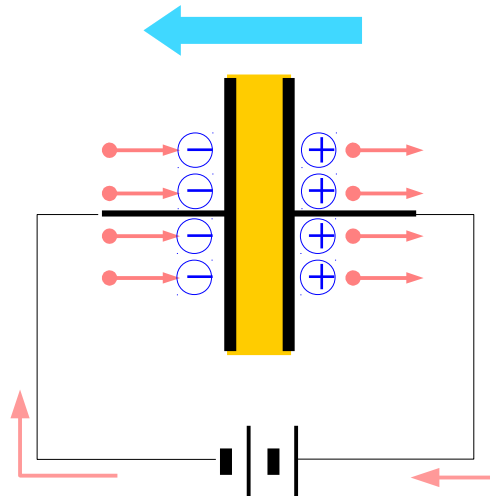

electron flow direction

Crowded →
No more space

no current

An AC Voltage Source

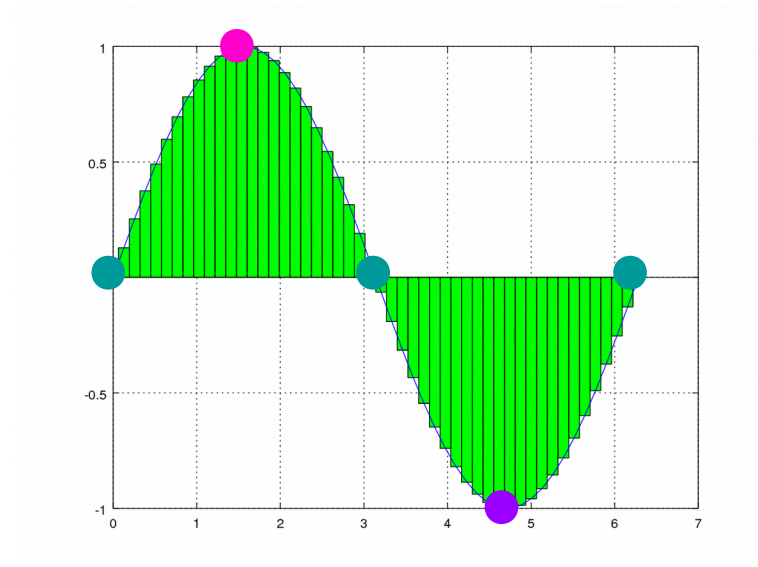
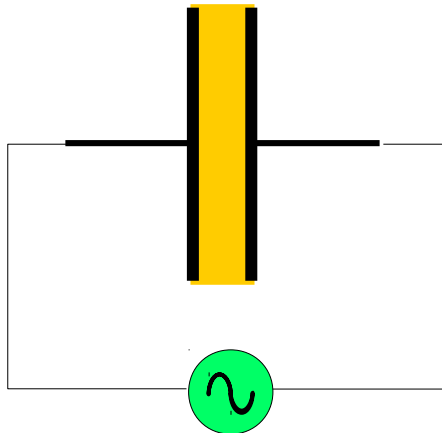

An AC Voltage Source

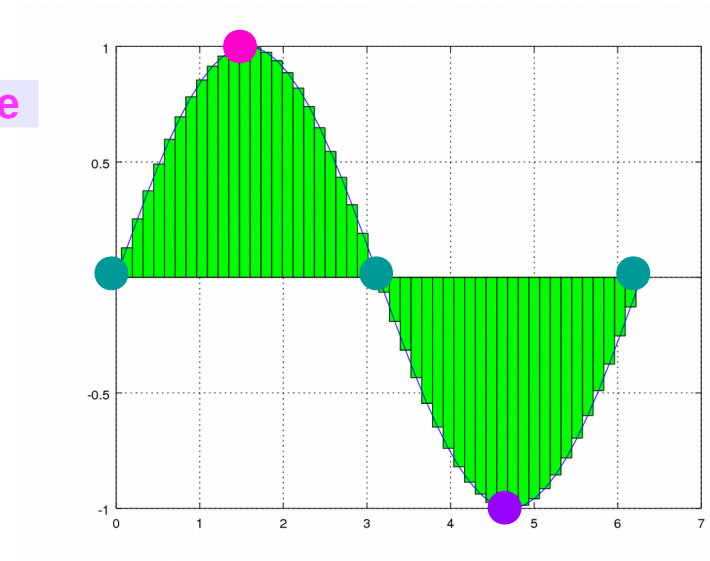
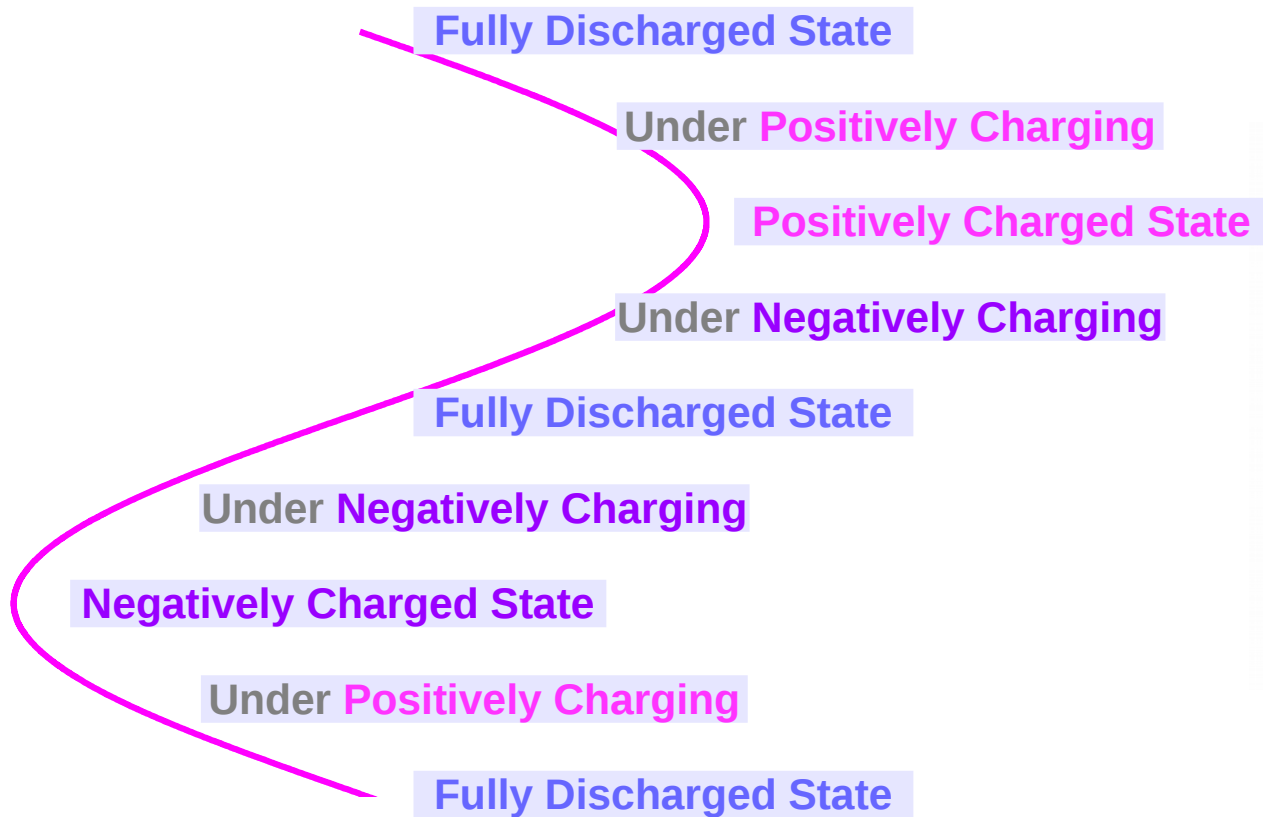

Fully Charged and Fully Discharged

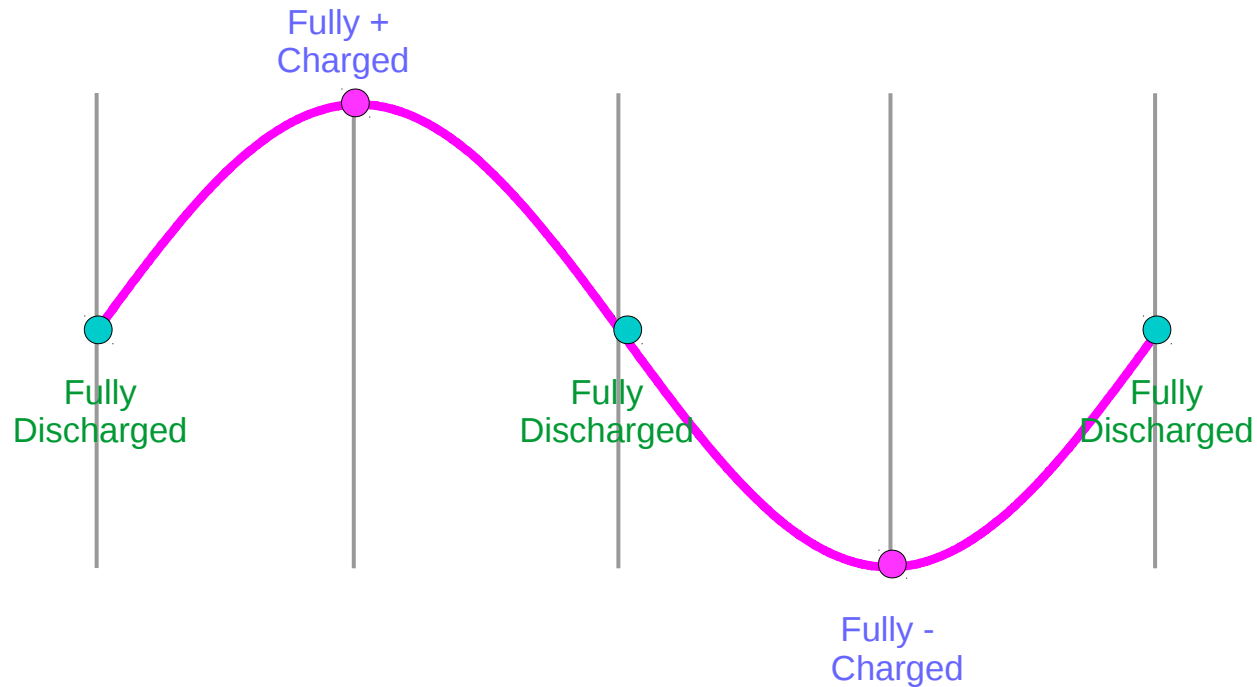

(+) Charging	(-) Charging	(-) Charging	(+) Charging
(+) current	(-) current	(-) current	(+) current
(+) Charging	(+) Discharging	(-) Charging	(-) Discharging

A Cycle

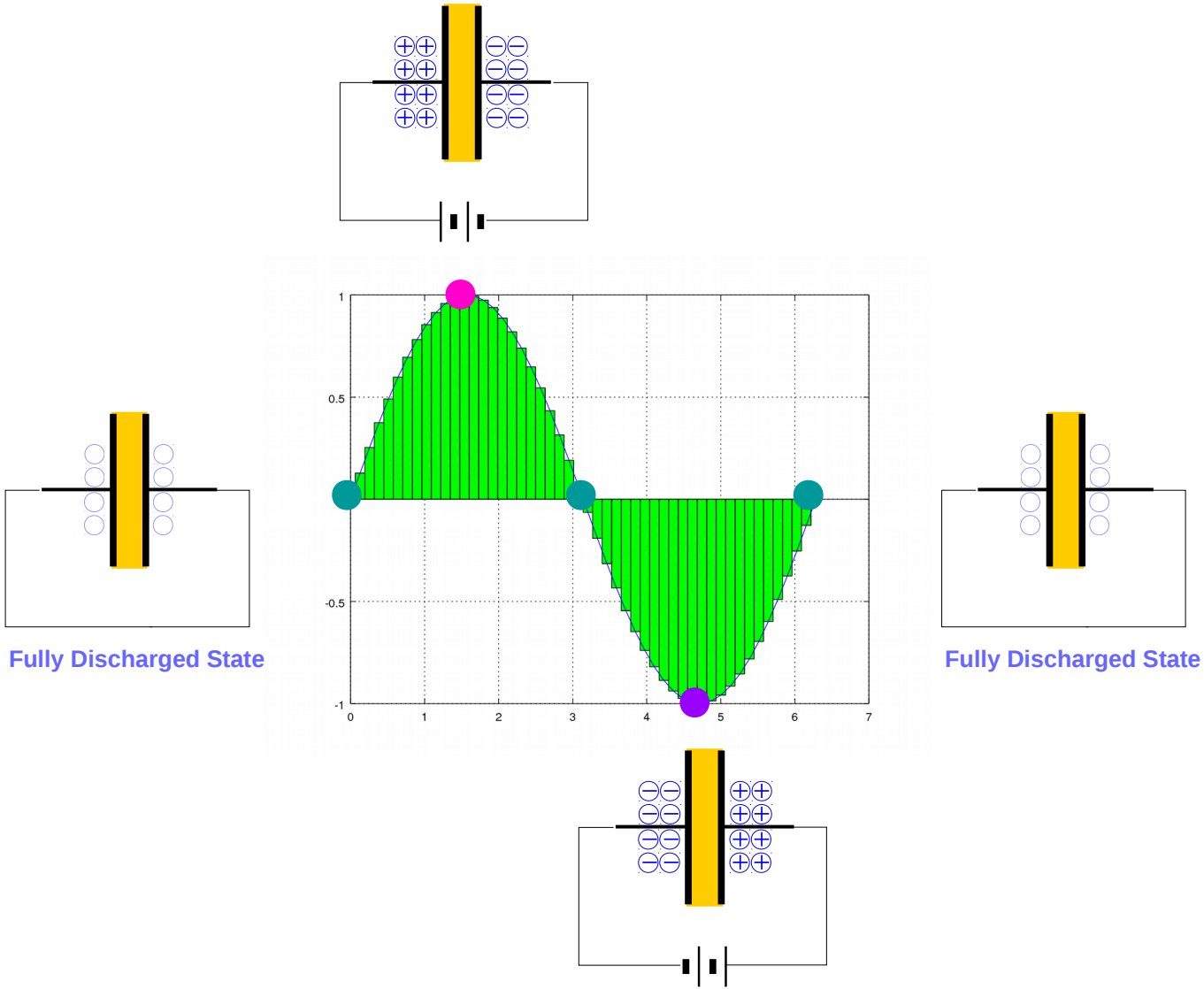

State Transition Diagram

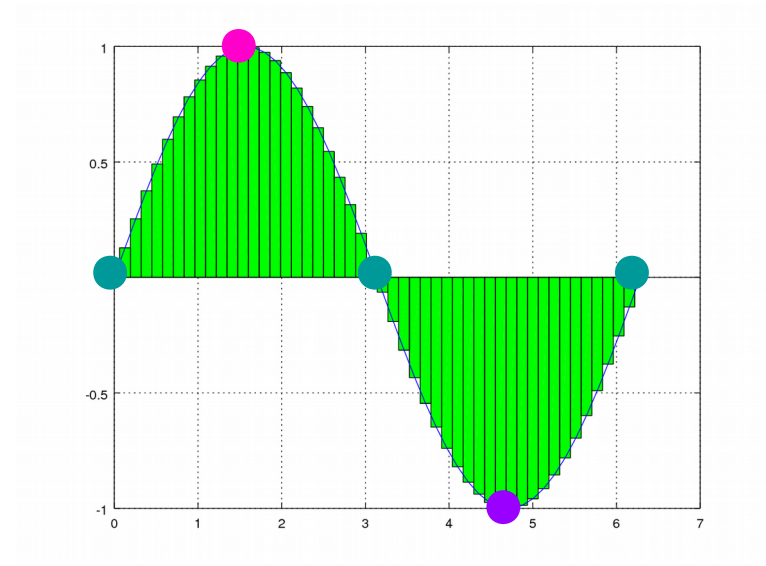
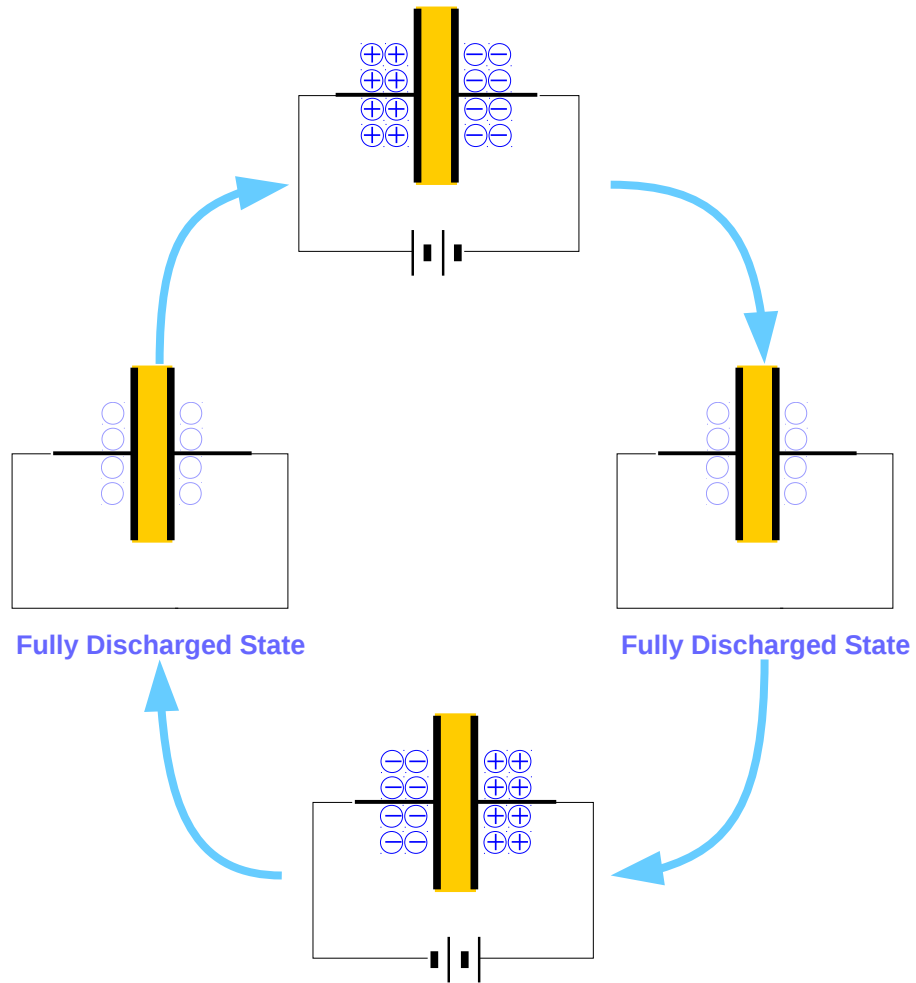

Current Flow

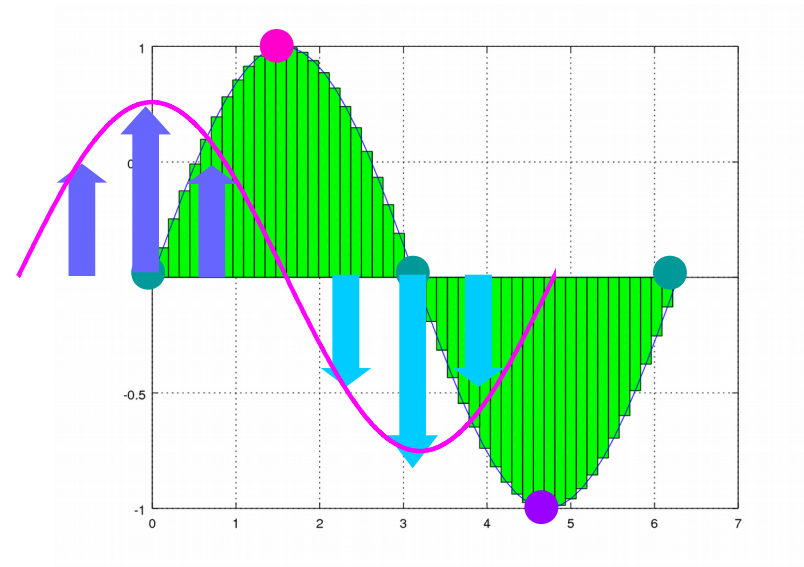
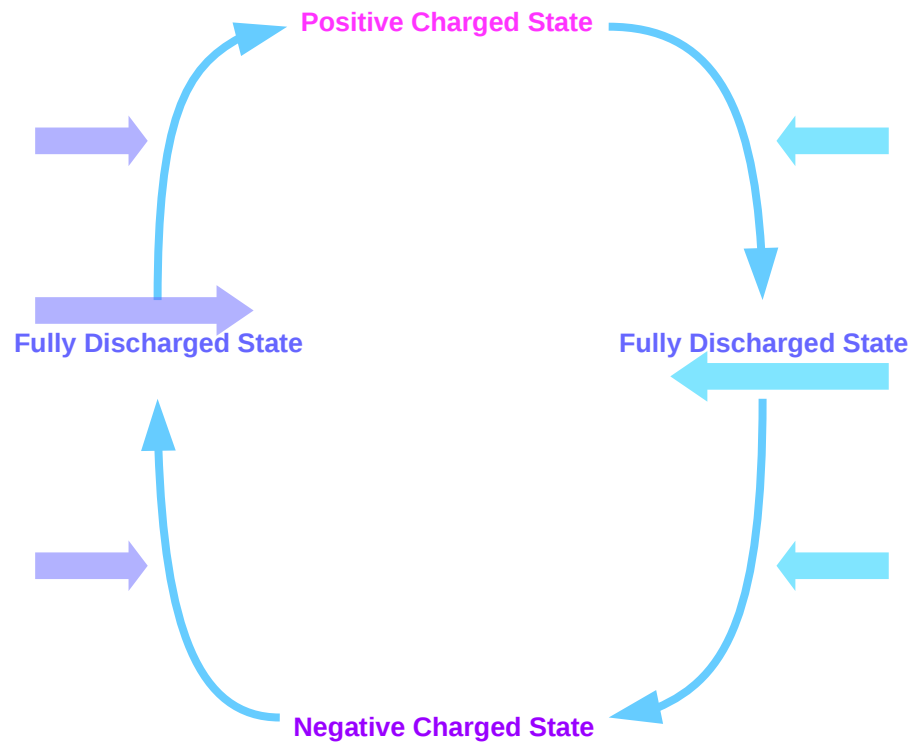

Continuous Charging and Discharging Operations

Incremental Voltage Increment \rightarrow + Charging incrementally

Incremental Voltage Decrement \rightarrow - Charging incrementally

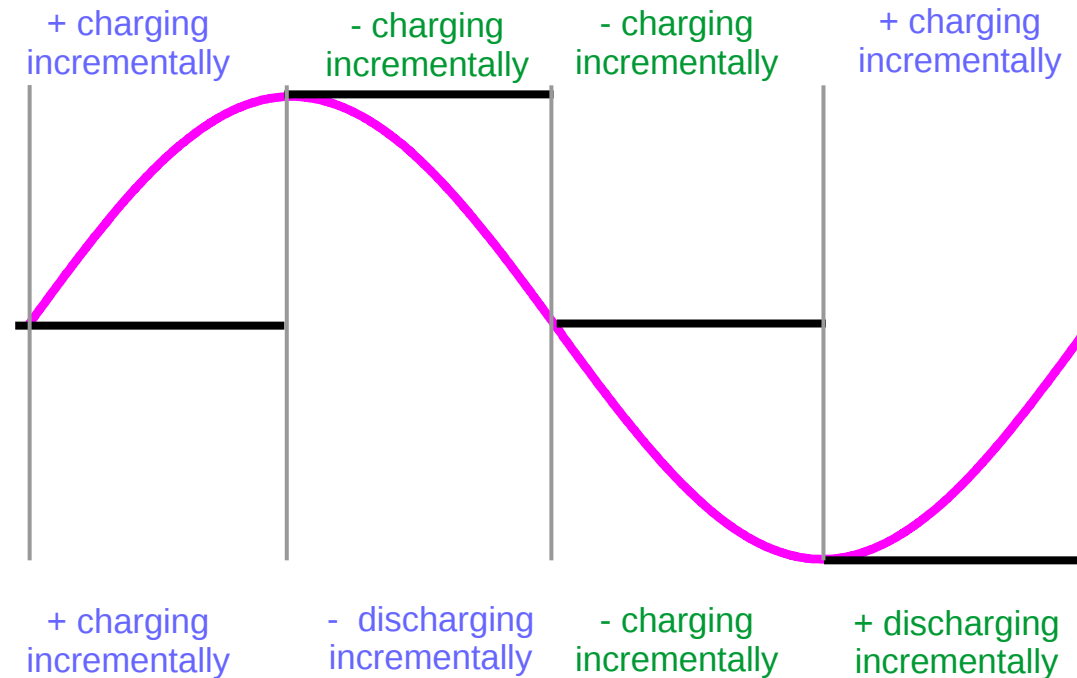

Fully Discharged : Large Current

Incremental Voltage Increment → Continuous Charging
Incremental Voltage Decrement → Continuous Discharging

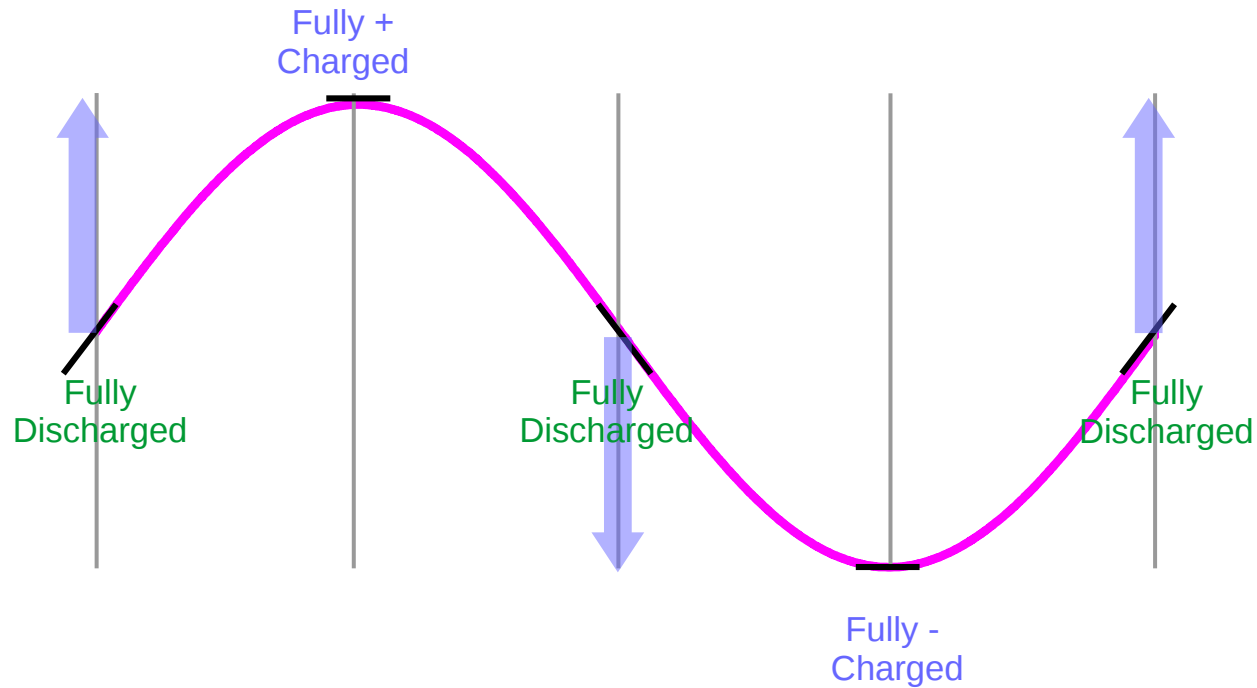

$y[n+1] - y[n]$

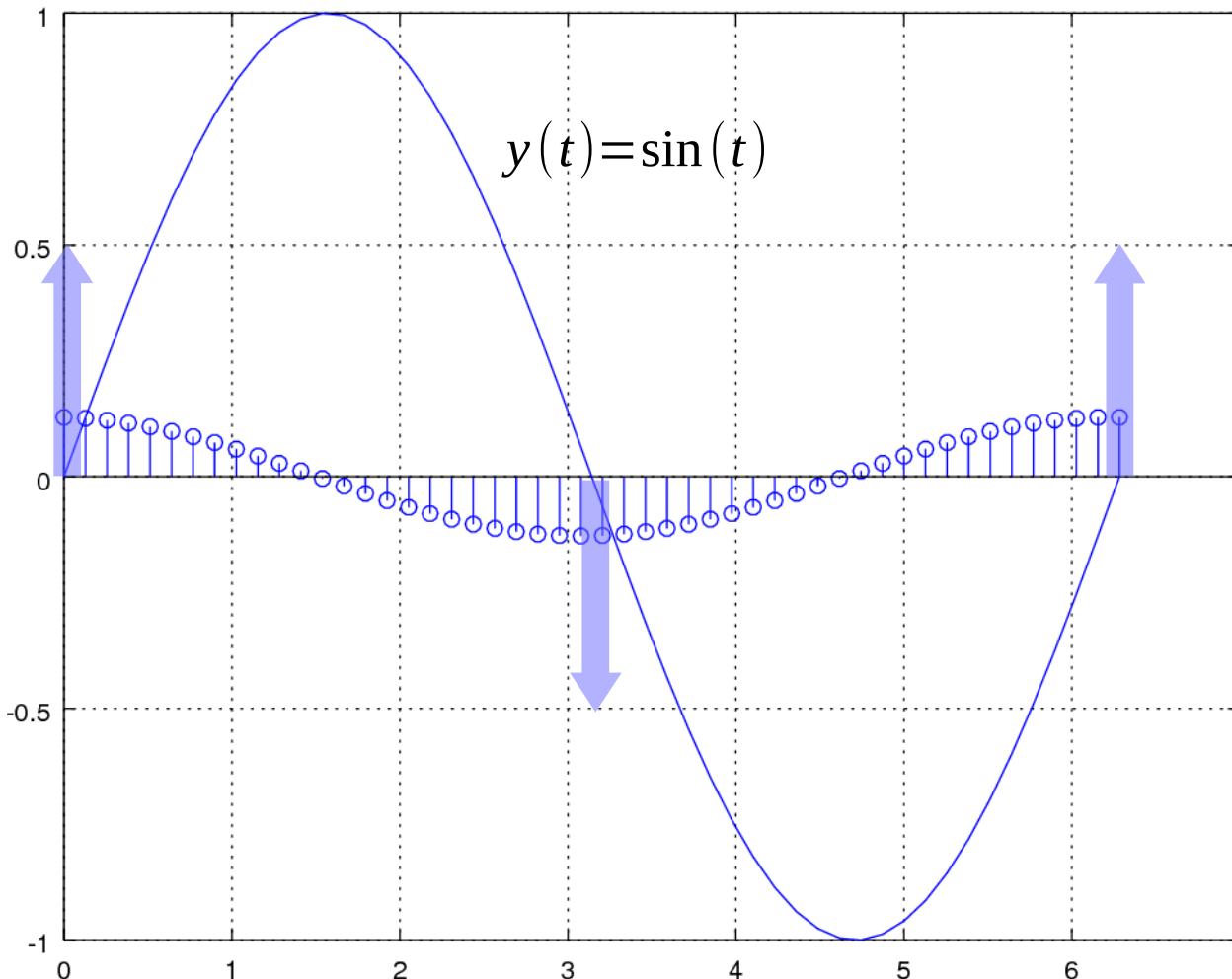

```
t = linspace(0, pi*2, 50);  
t1 = t;  
t2 = t + t(2);  
y1 = sin(t1);  
y2 = sin(t2) - sin(t1);  
stem(t1, y2)  
hold on  
plot(t1, y1)
```

$$y[n] - y[n+1] = y(nT) - y((n+1)T) = \sin(nT) - \sin((n+1)T)$$

Fully Charged and Fully Discharged

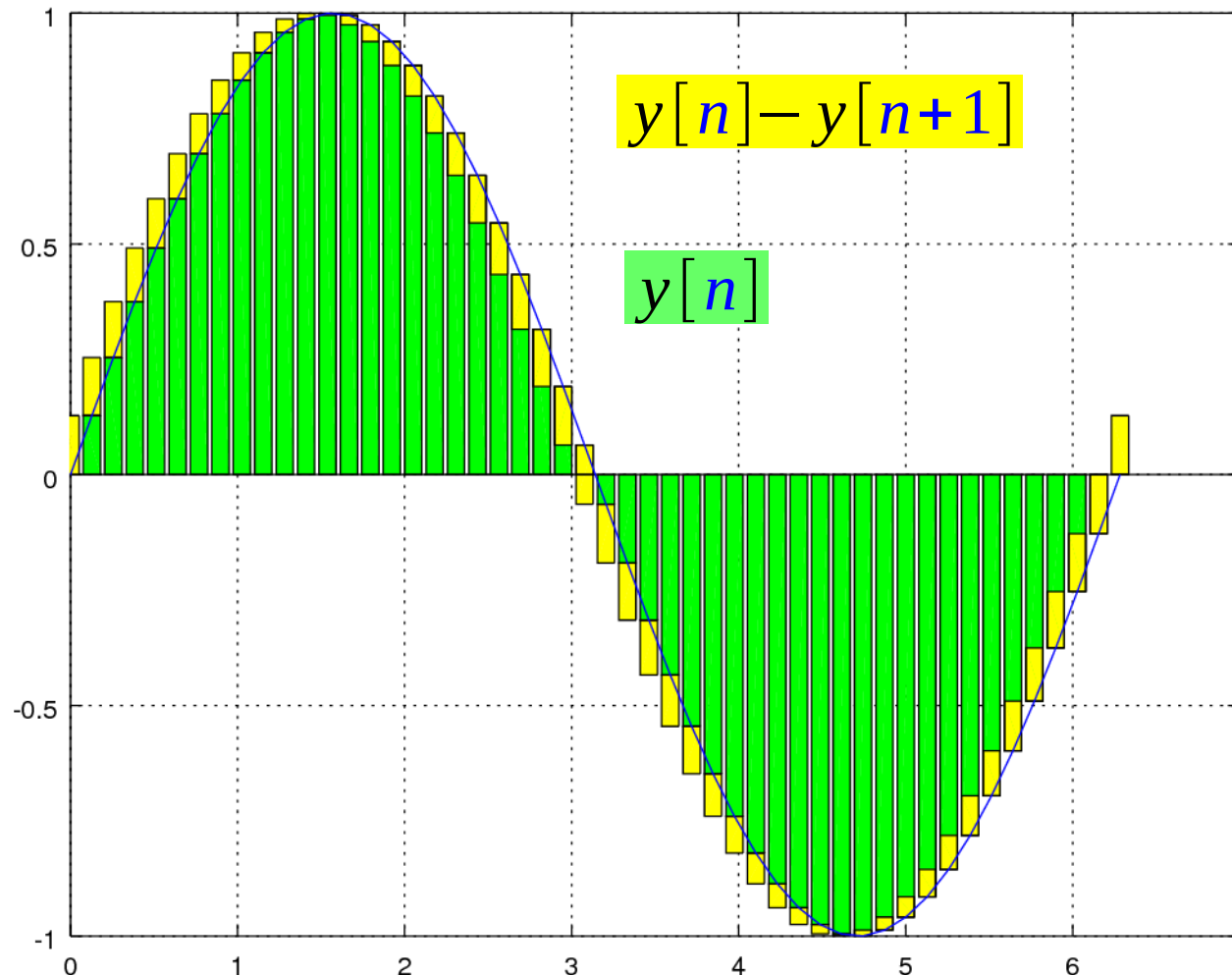

```
h = bar(t1, [y1' y2'],  
"stacked")  
set(h(1), "facecolor", "g");  
set(h(2), "facecolor", "y");  
hold on  
plot(t1, y1)  
axis([0 7 -1 1]);
```

$$y[n] - y[n+1] = y(nT) - y((n+1)T) = \sin(nT) - \sin((n+1)T)$$

Fully Charged and Fully Discharged

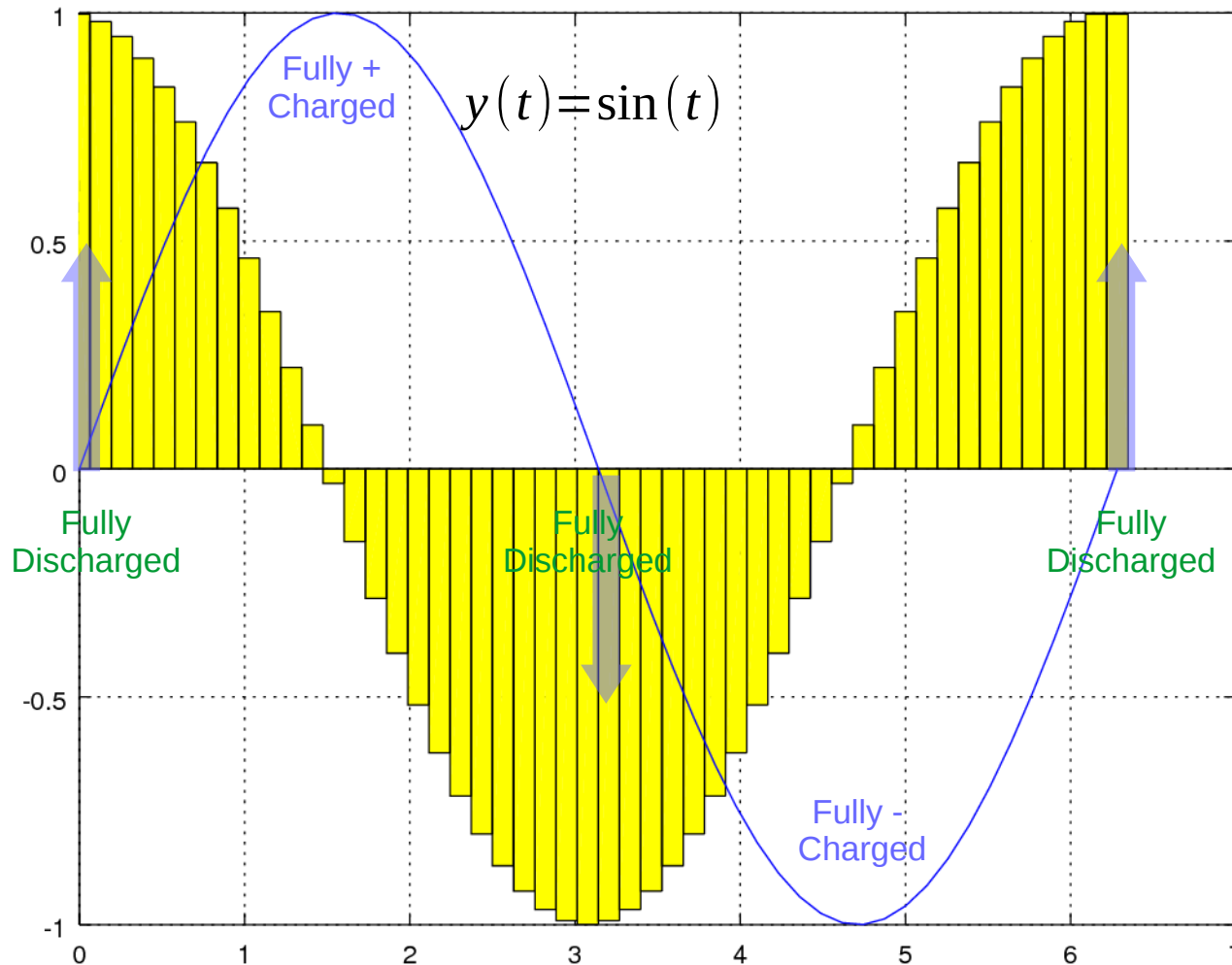

```
h = bar(t1, y2/t(2), "hist")
set(h(1), "facecolor", "y");
hold on
plot(t1, y1)
axis([0 7 -1 1]);
```

$$\frac{y[n] - y[n+1]}{T}$$

$$\propto \frac{dy}{dt}$$

Fully Charged and Fully Discharged

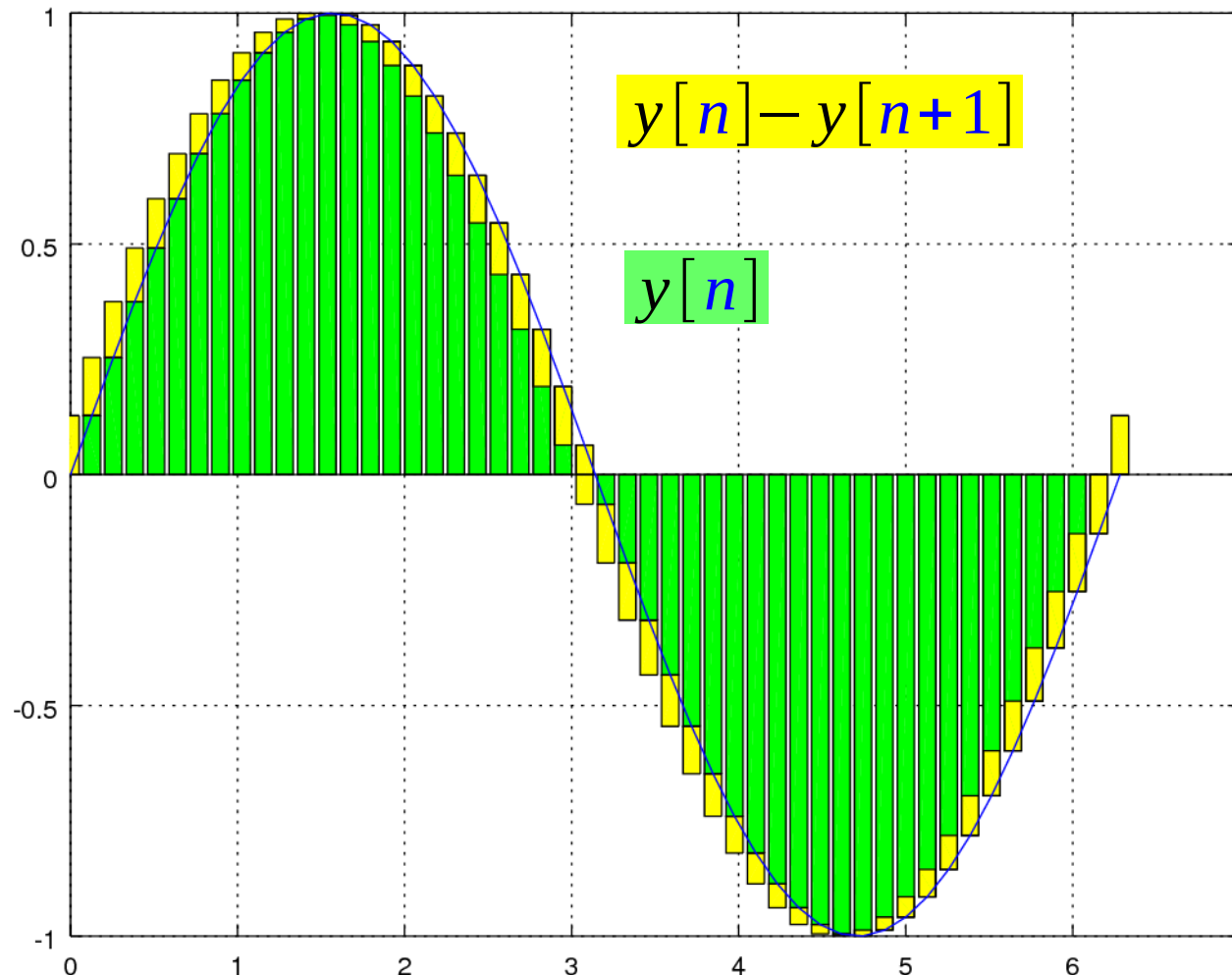

```
h = bar(t1, [y1' y2'],  
"stacked")  
set(h(1), "facecolor", "g");  
set(h(2), "facecolor", "y");  
hold on  
plot(t1, y1)  
axis([0 pi]);
```

$$y[n] - y[n+1] = y(nT) - y((n+1)T) = \sin(nT) - \sin((n+1)T)$$

Fully Charged and Fully Discharged

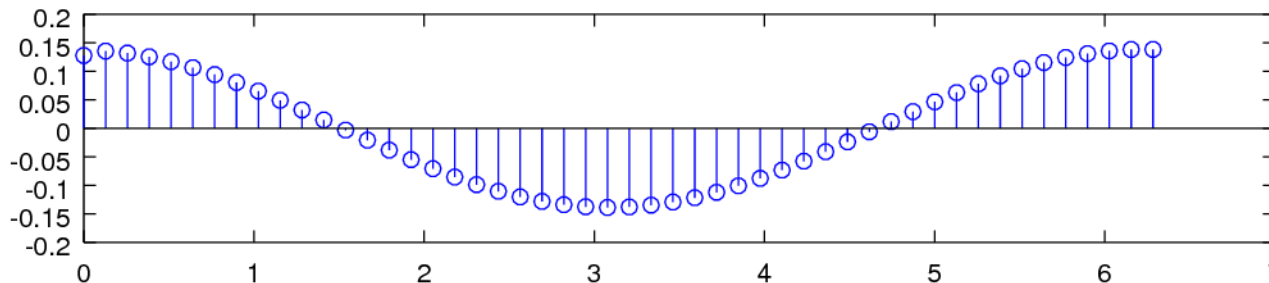
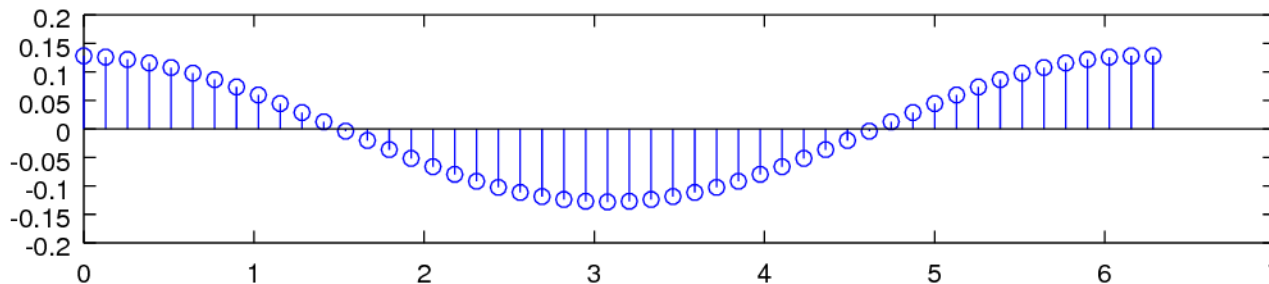
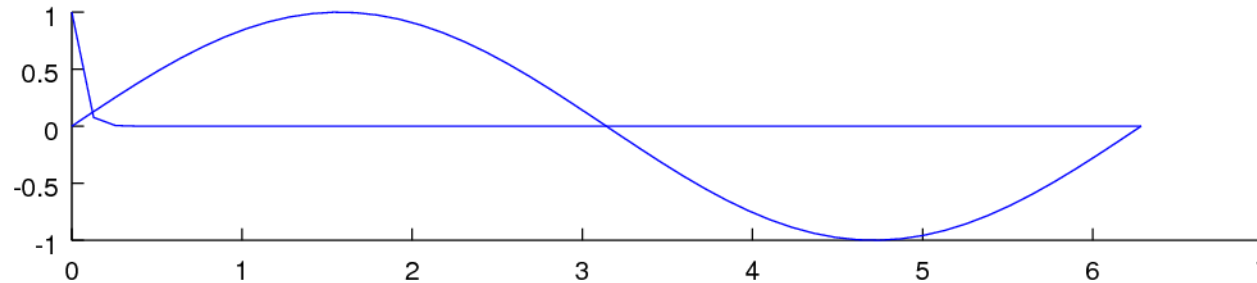

```
clf
t = linspace(0, pi*2, 50);
t1 = t;
t2 = t + t(2);
y1 = sin(t1);
y2 = sin(t2) - sin(t1);
y3 = e.^(-20*t);
y4 = conv(y2, y3);
y5 = y4([1:length(t1)]);
```

```
subplot(3, 1, 2);
stem(t1, y2)
subplot(3, 1, 1);
hold on
plot(t1, y1);
plot(t1, y3);
subplot(3, 1, 3);
stem(t1, y5);
```

Pulse

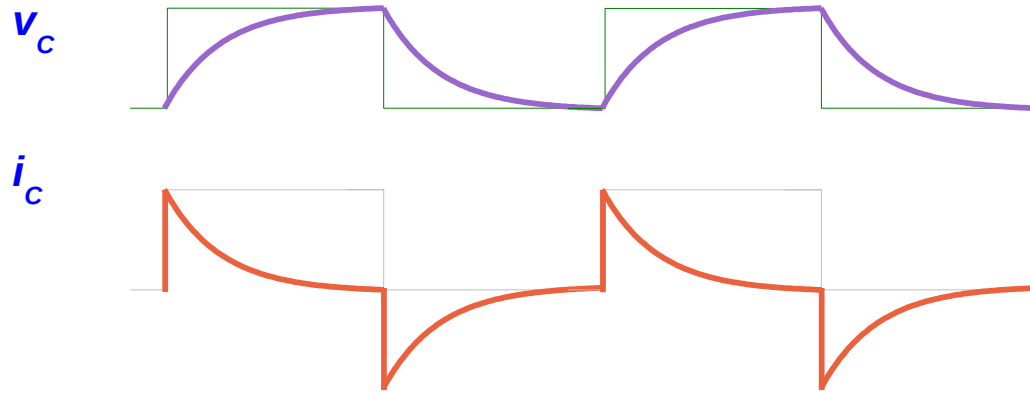

$$i_c = C \frac{dv_c}{dt}$$

ω ↑ i_c ↑ X_c ↓

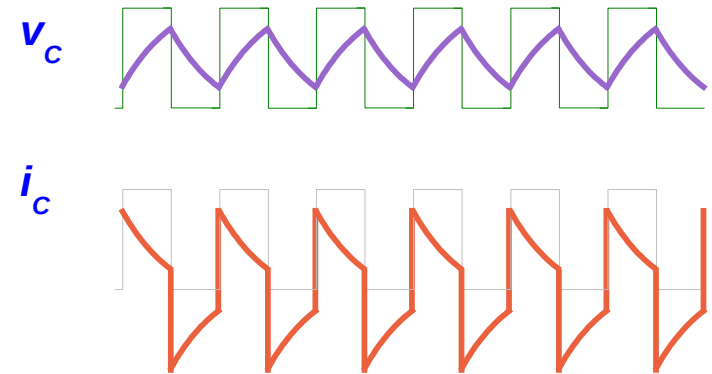
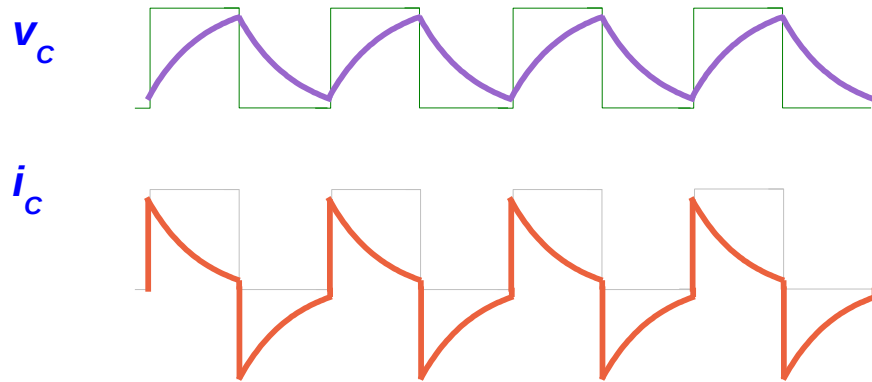

Time Constants

i_c

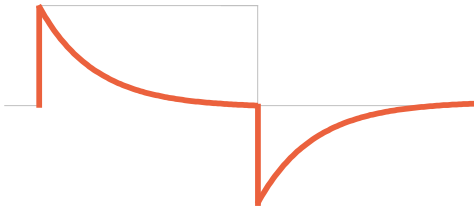

$\tau = RC$ *small time constant*

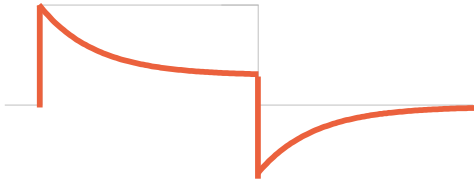

$\tau = RC$ *medium time constant*

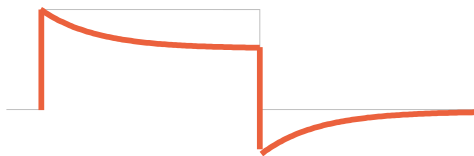

$\tau = RC$ *large time constant*

Time Constants

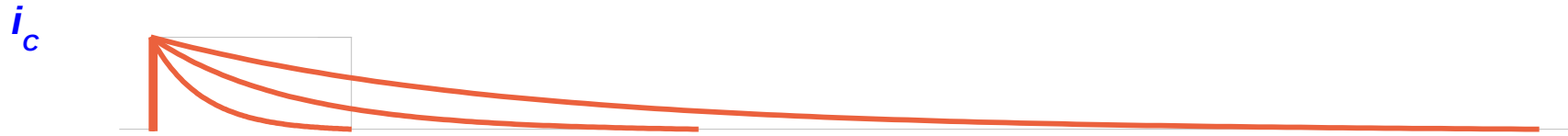

$$\tau_1 < \tau_2 < \tau_3$$

$$a_1 > a_2 > a_3$$

$$e^{-\frac{t}{\tau}} = e^{-\frac{t}{RC}} = e^{-at}$$

$$\tau = RC = \frac{1}{a}$$

Time Constants

i_c

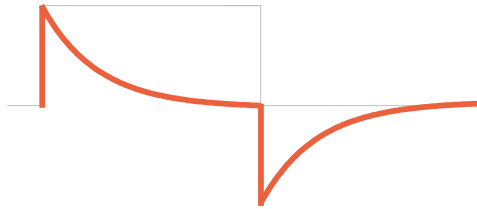

$$\tau = RC$$

$$e^{-\frac{t}{\tau}} = e^{-\frac{t}{RC}}$$

small τ
small C

$$\text{large } \frac{1}{\omega C} \gg R$$

Fully Capacitive



$$\tau = RC$$

$$e^{-\frac{t}{\tau}} = e^{-\frac{t}{RC}}$$

large τ
large C

$$\text{small } \frac{1}{\omega C} \ll R$$

Fully Resistive

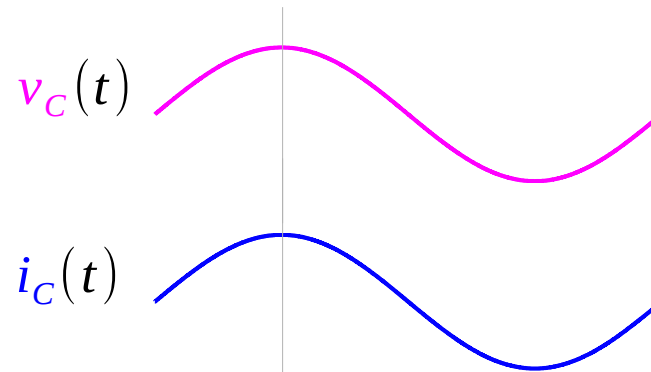
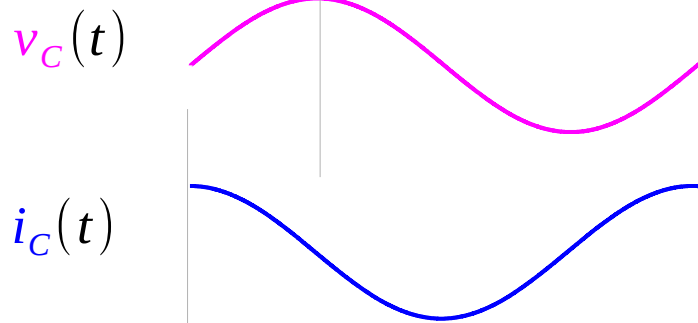

Time Constants

i_c

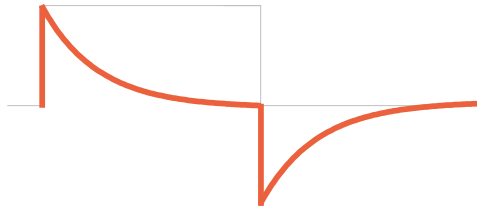

$$\tau = RC$$
$$e^{-\frac{t}{\tau}} = e^{-\frac{t}{RC}}$$

small τ
small C

$$\text{large } \frac{1}{\omega C} \gg R$$

Fully Capacitive

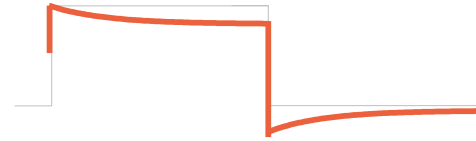

$$\tau = RC$$
$$e^{-\frac{t}{\tau}} = e^{-\frac{t}{RC}}$$

large τ
large C

$$\text{small } \frac{1}{\omega C} \ll R$$

Fully Resistive

Superposition - Small Time Constant

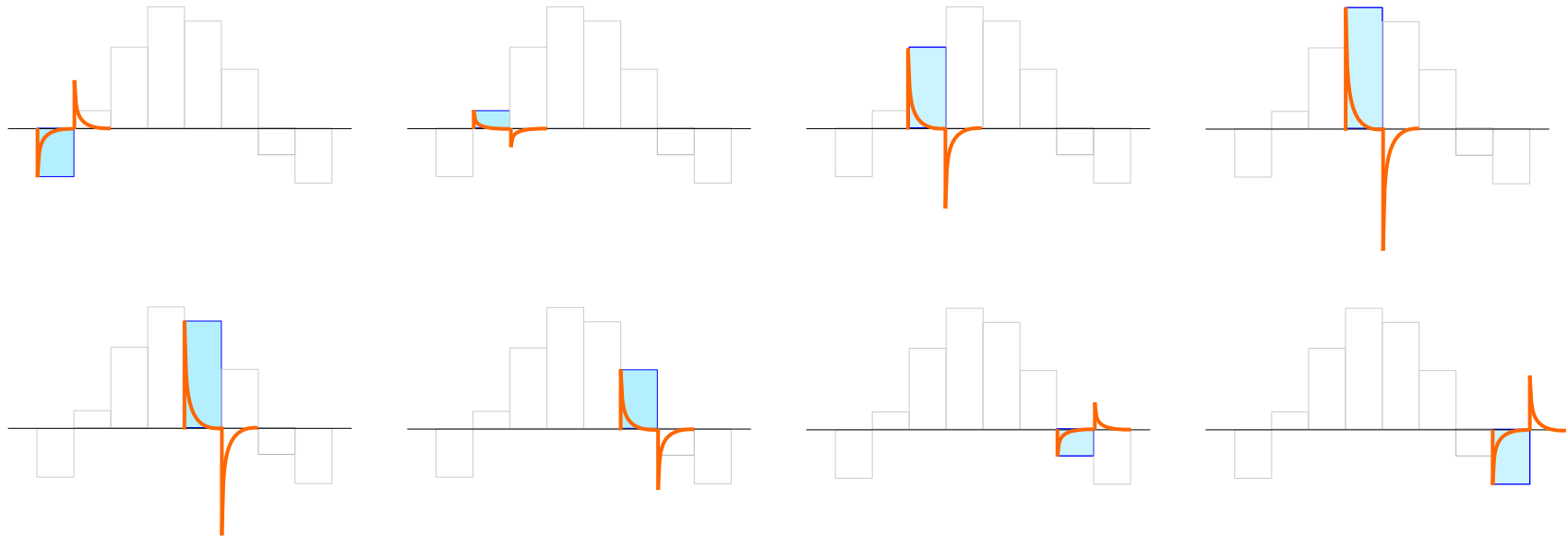

Small Time Constants

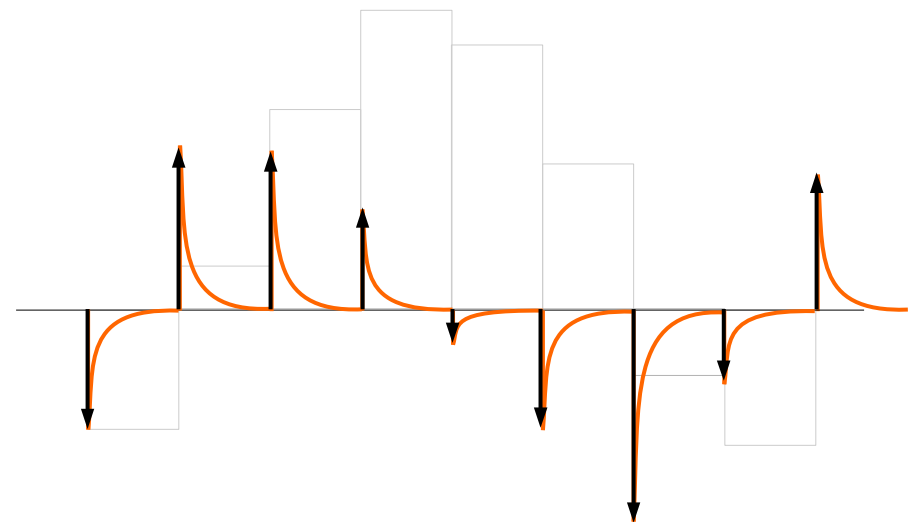
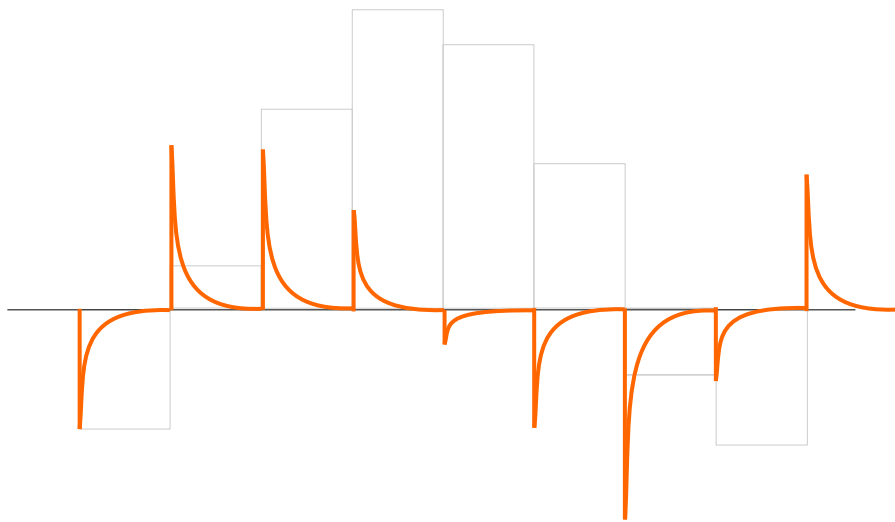
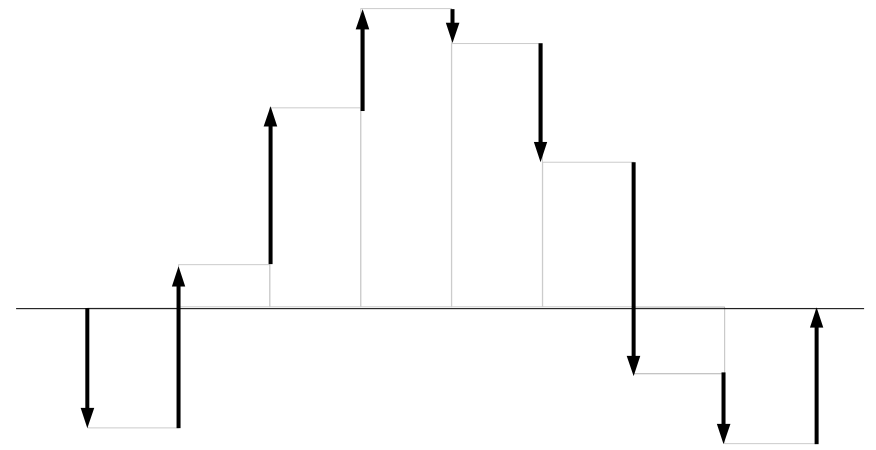
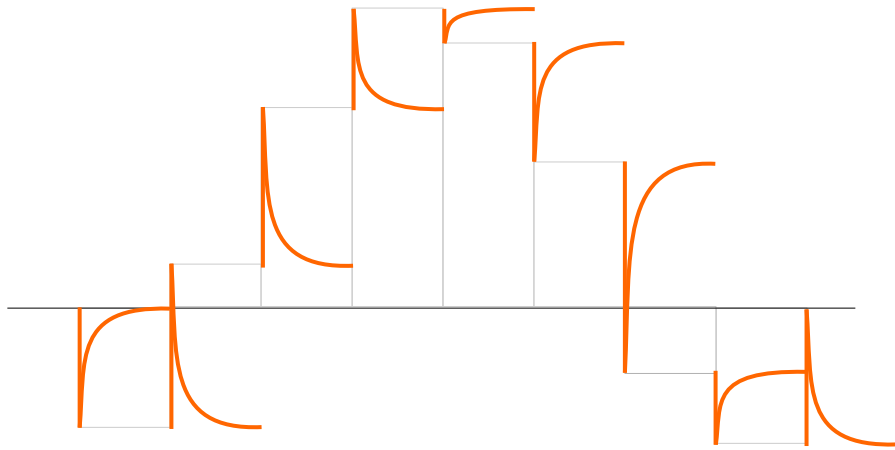

Superposition - Large Time Constant

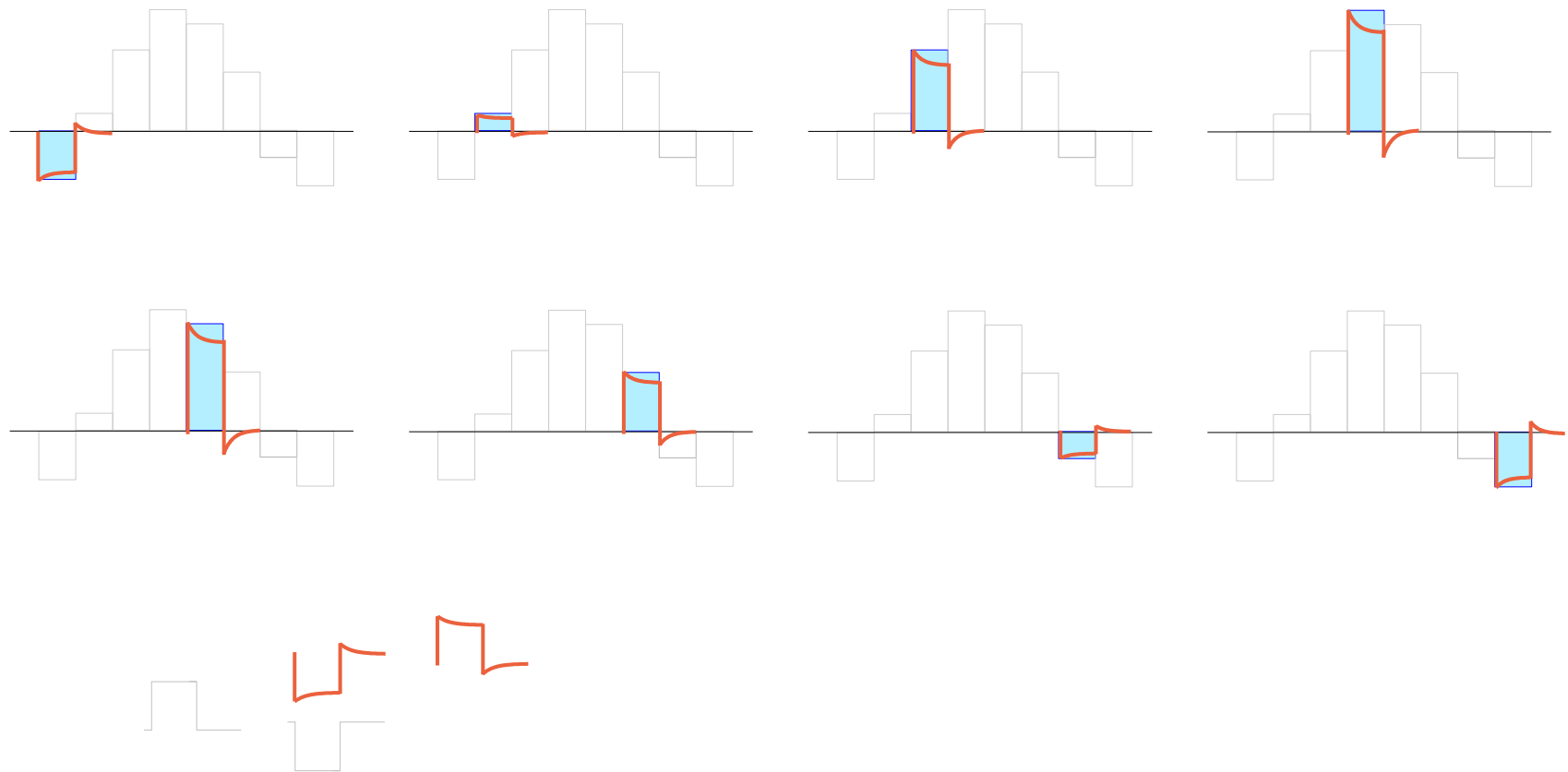

Large Time Constants

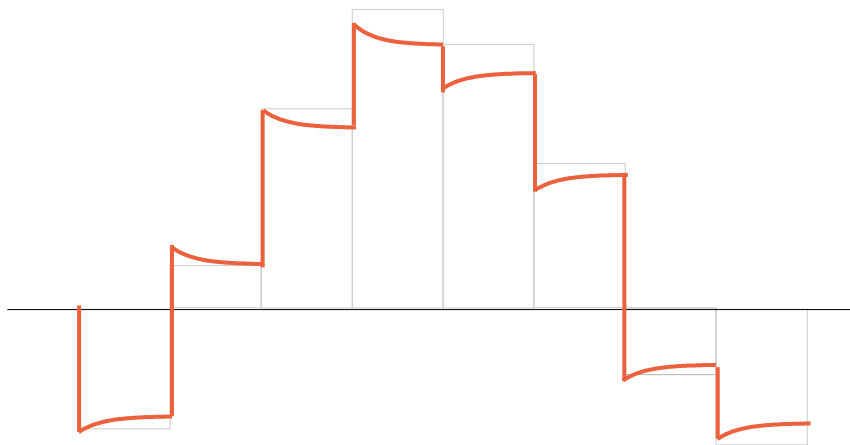
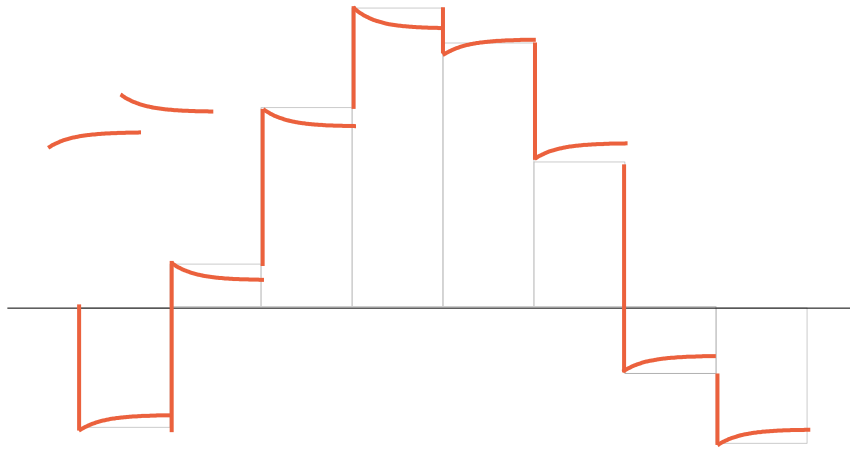

Time Constants

i_c

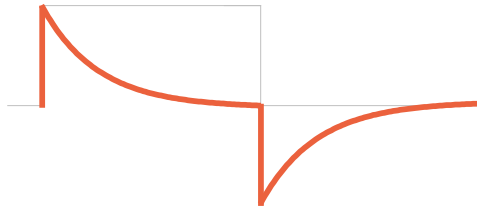

$$\tau = RC$$

$$e^{-\frac{t}{\tau}} = e^{-\frac{t}{RC}}$$

small τ
small C

$$\text{large } \frac{1}{\omega C} \gg R$$



$$\tau = RC$$

$$e^{-\frac{t}{\tau}} = e^{-\frac{t}{RC}}$$

large τ
large C

$$\text{small } \frac{1}{\omega C} \ll R$$

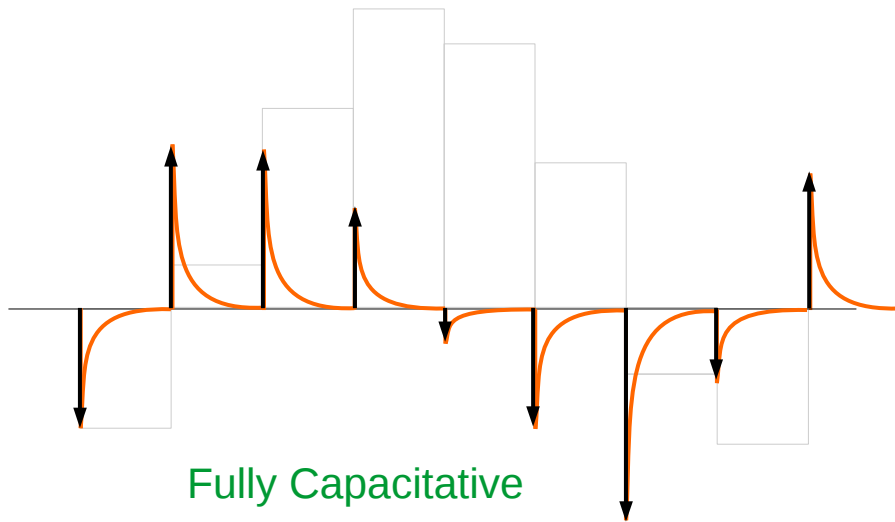

Fully Capacitive

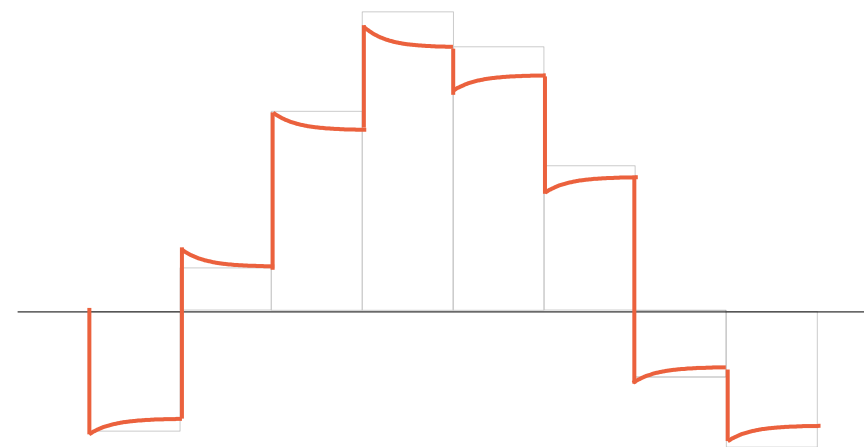

Fully Resistive

Plotting superposition results

```
clf
t = linspace(0, pi*2, 50);
tt= linspace(0, pi*2, 500);
N = length(t);
NN= length(tt);

t1 = t;
t2 = [t(2:N), t(N)];
y1 = sin(t1);
y2 = sin(t2) - sin(t1);

yy = [y1; zeros(NN/N-1, N)];
yy2= yy(:)';
a = 1/300;
yy3= e.^(-a*tt);
yy3 =yy3 - [zeros(1, NN/N),
e.^(-a*tt)](1:NN);

svec = zeros(1, NN);
for i = 1:NN;
    tvec = zeros(1, NN);
    tvec = [zeros(1, i-1), yy3];
    tvec = yy2(i) * tvec(1:NN);
    svec = svec + tvec;
endfor
yy4 = svec;
% yy4= conv(yy2, yy3);
y5 = yy4([1:NN/N:NN]);
yy5= yy4([1:NN]);

subplot(4, 1, 2);
stem(t1, y2)
subplot(4, 1, 1);
hold on
plot(t1, y1);
plot(tt, yy3);
subplot(4, 1, 3);
stem(t1, y5); hold on
plot(tt, yy5)
subplot(4, 1, 4);
plot(yy4);
```

Small Time Constant

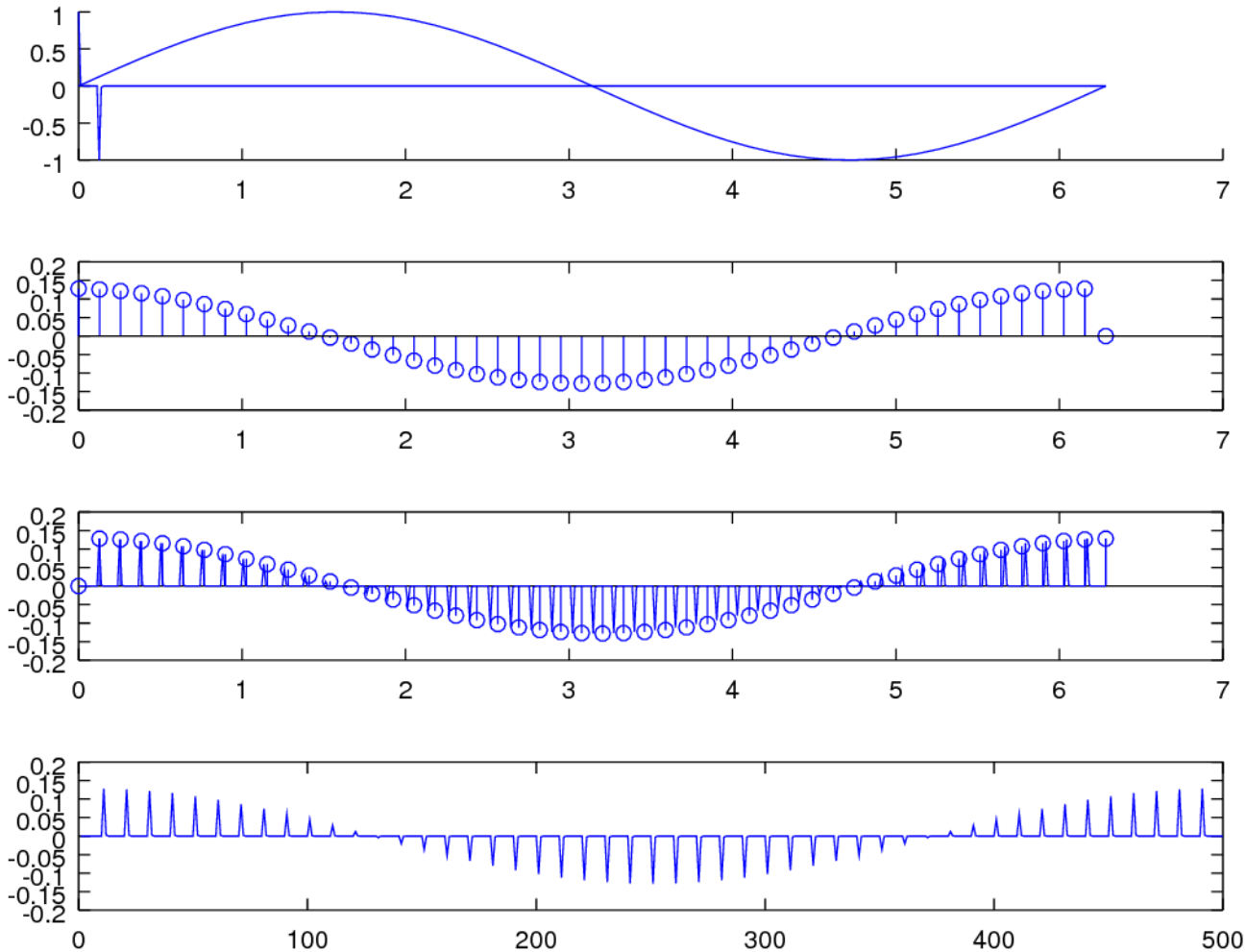

```
yy = [y1;  
zeros(NN/N-1, N)];  
yy2= yy(:)';  
a = 300;  
yy3= e.^(-a*tt);  
yy3 =yy3 -  
[zeros(1, NN/N),  
e.^(-a*tt)](1:NN);
```

$$\tau = RC$$

$$e^{-\frac{t}{\tau}} = e^{-\frac{t}{RC}}$$

small τ

small C

large $\frac{1}{\omega C}$

Large Time Constant

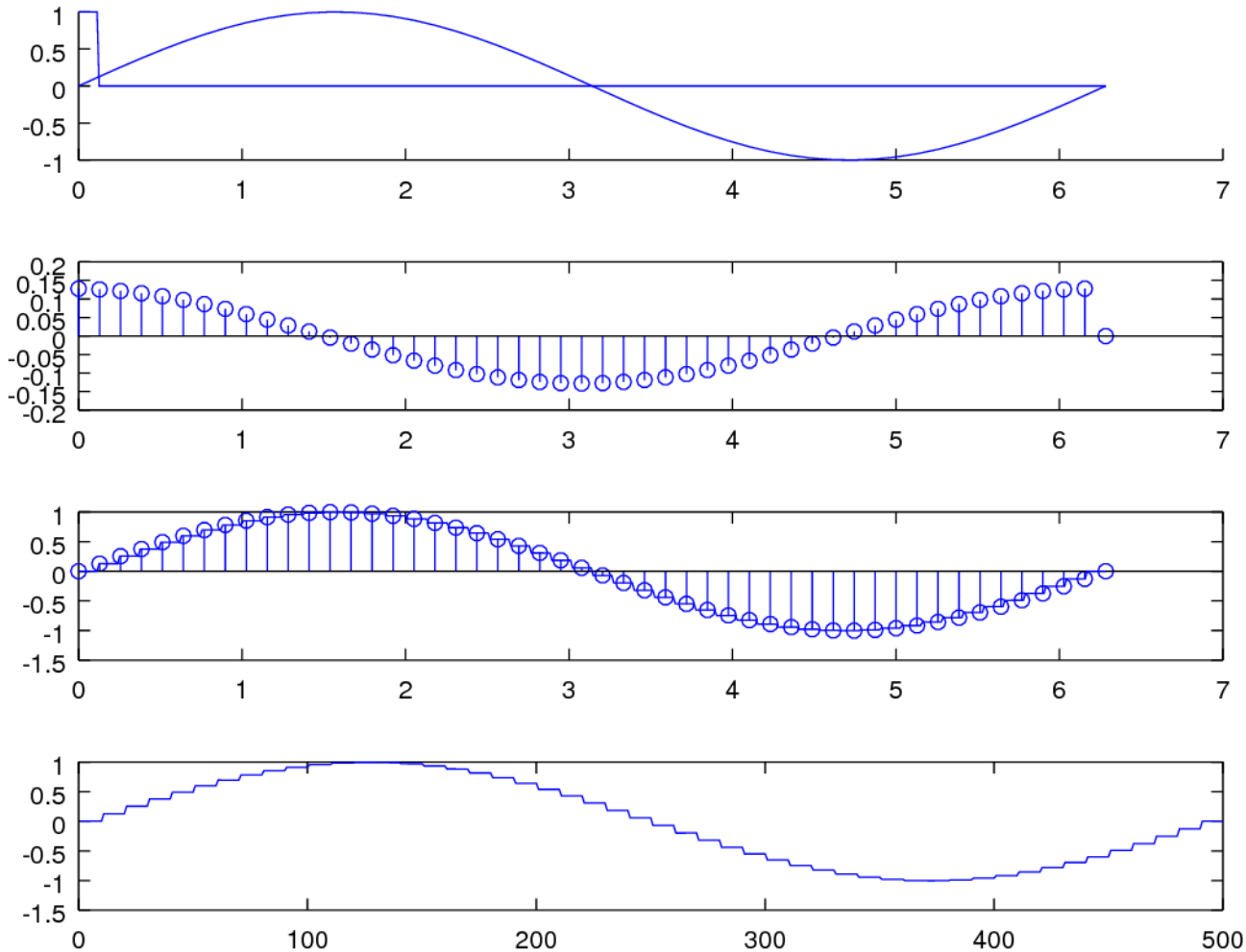

```
yy = [y1;
zeros(NN/N-1, N)];
yy2= yy(:)';
a = 1/300;
yy3= e.^(-a*tt);
yy3 =yy3 -
[zeros(1, NN/N),
e.^(-a*tt)](1:NN);
```

$$\tau = RC$$

$$e^{-\frac{t}{\tau}} = e^{-\frac{t}{RC}}$$

large τ

large C

small $\frac{1}{\omega C}$

Time Constants

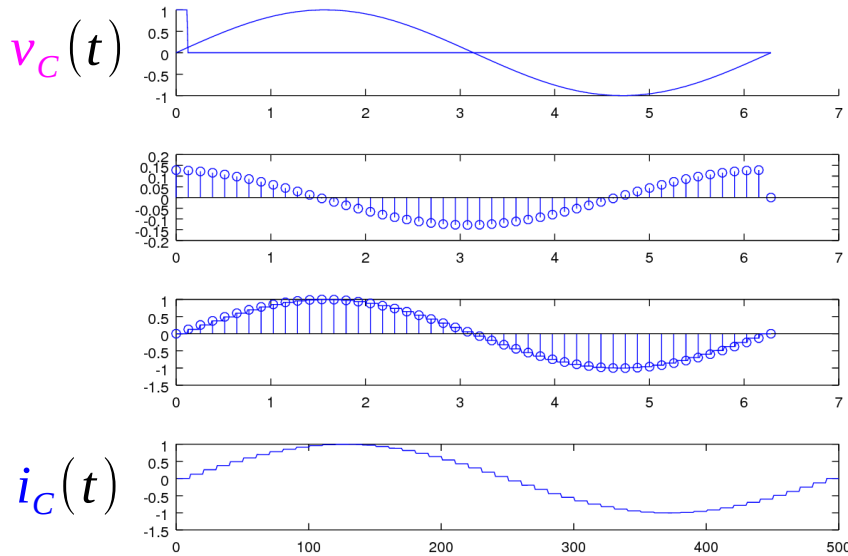
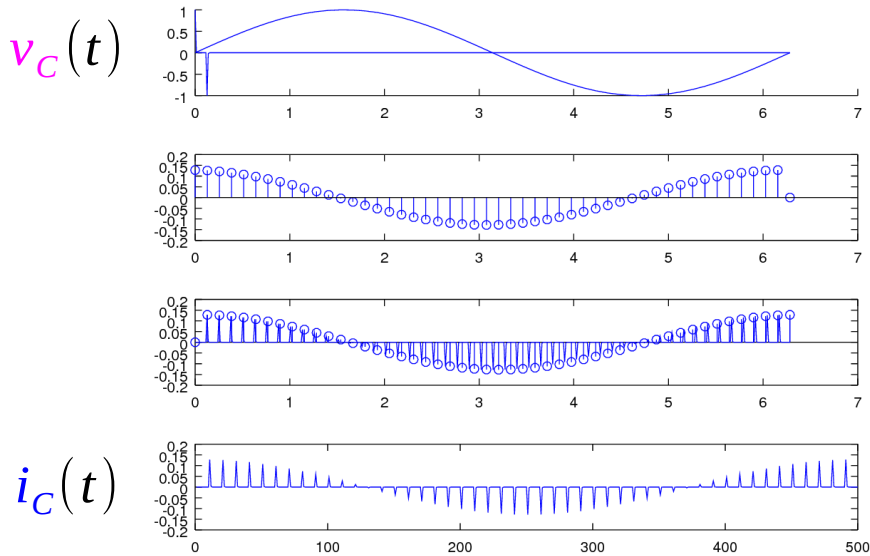
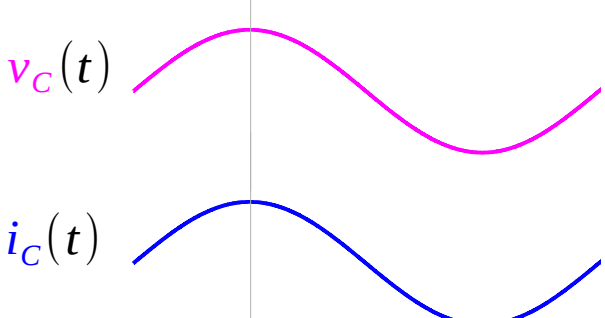
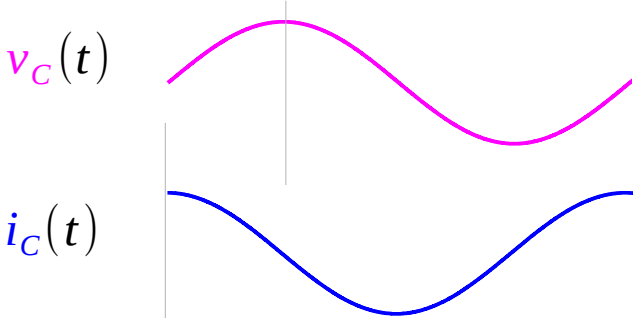

Evercharging signal pairs

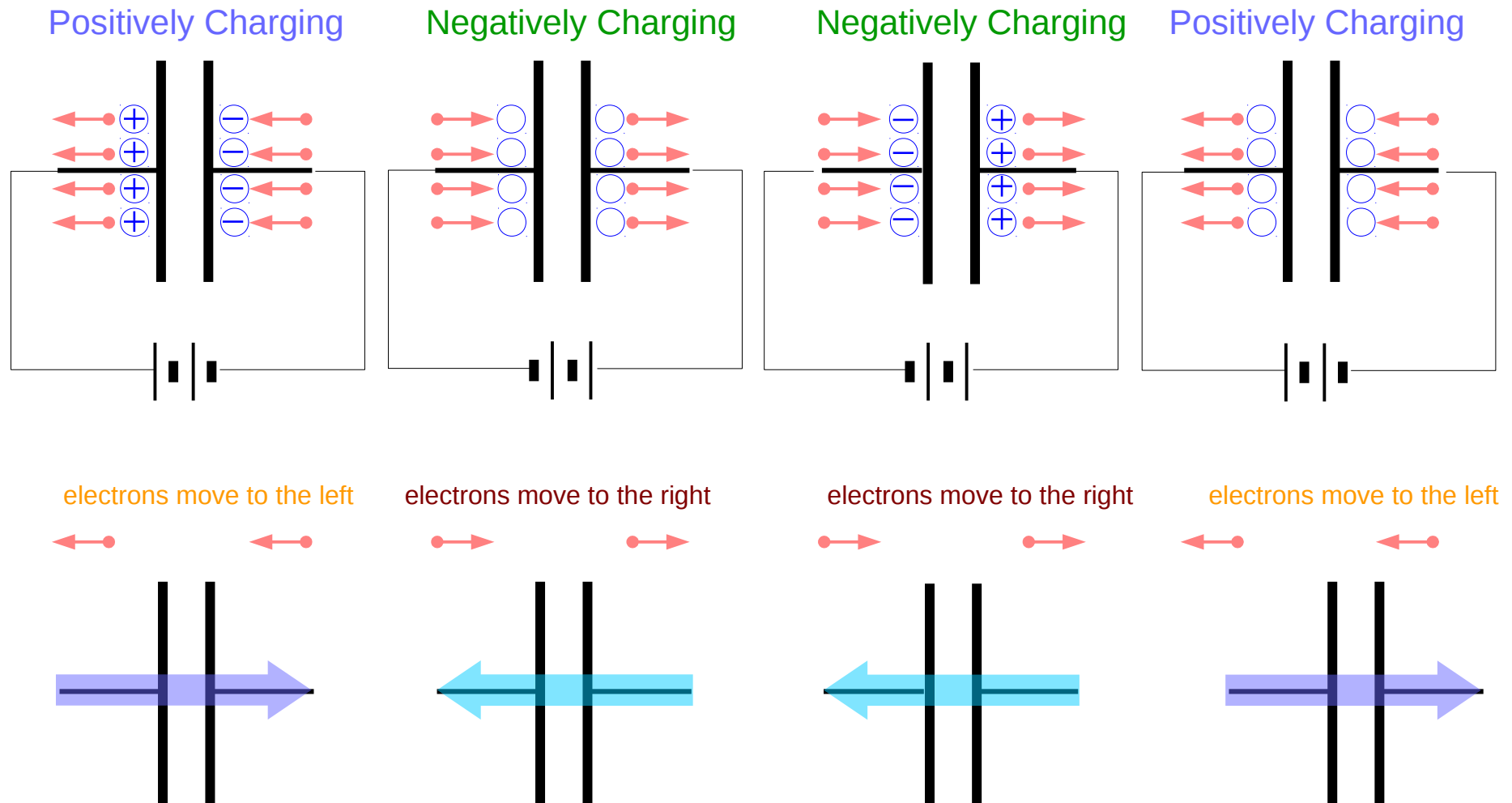

Continuous Charging and Discharging Operations

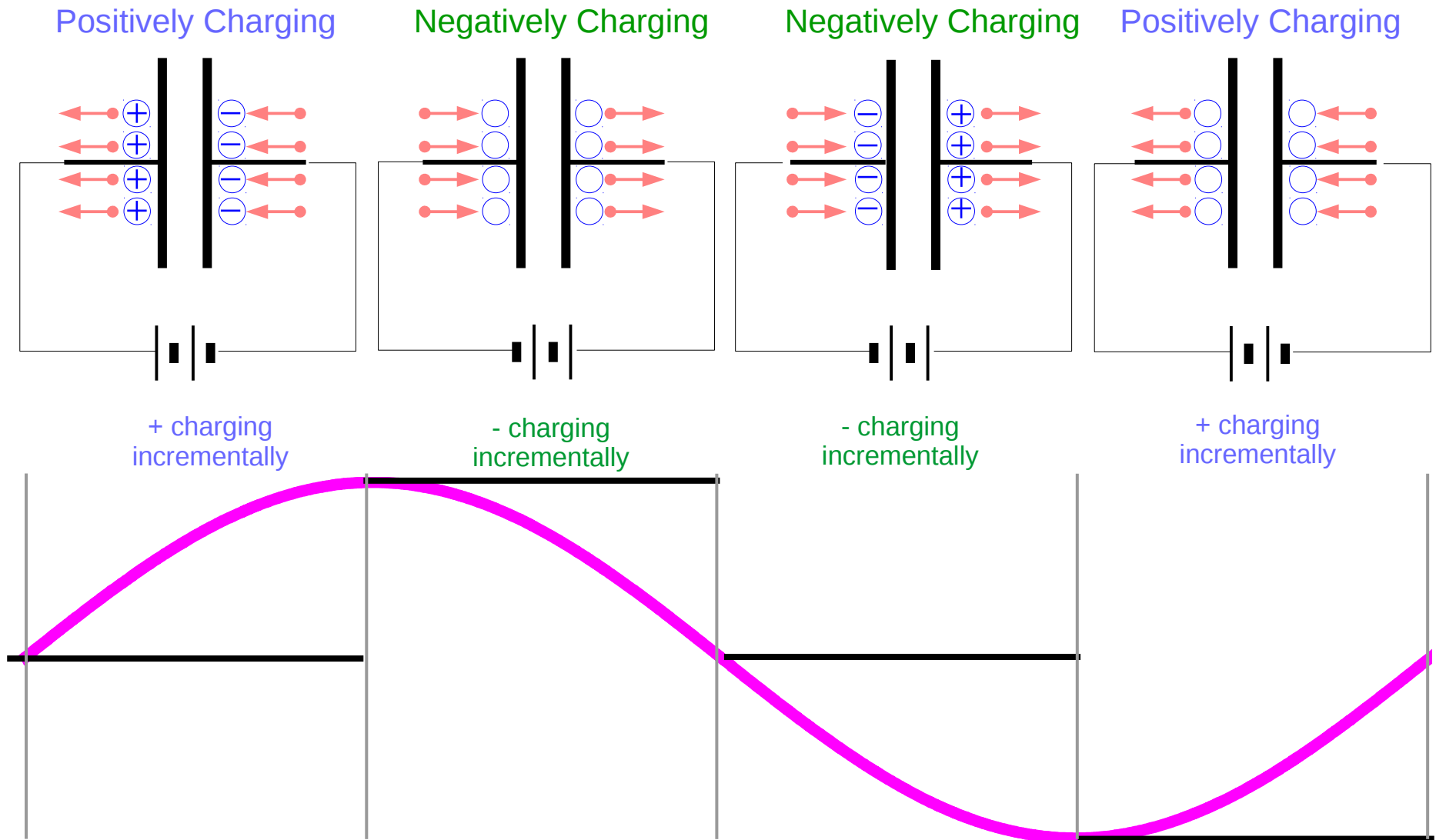

Everchanging signal pairs

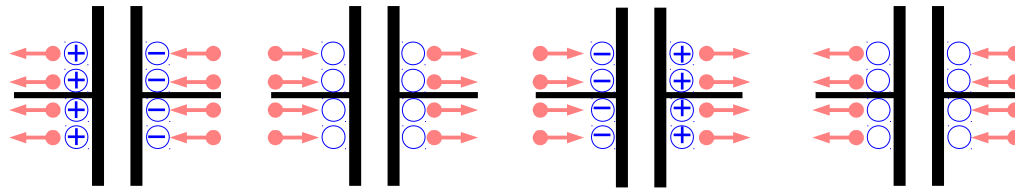

charge

discharge

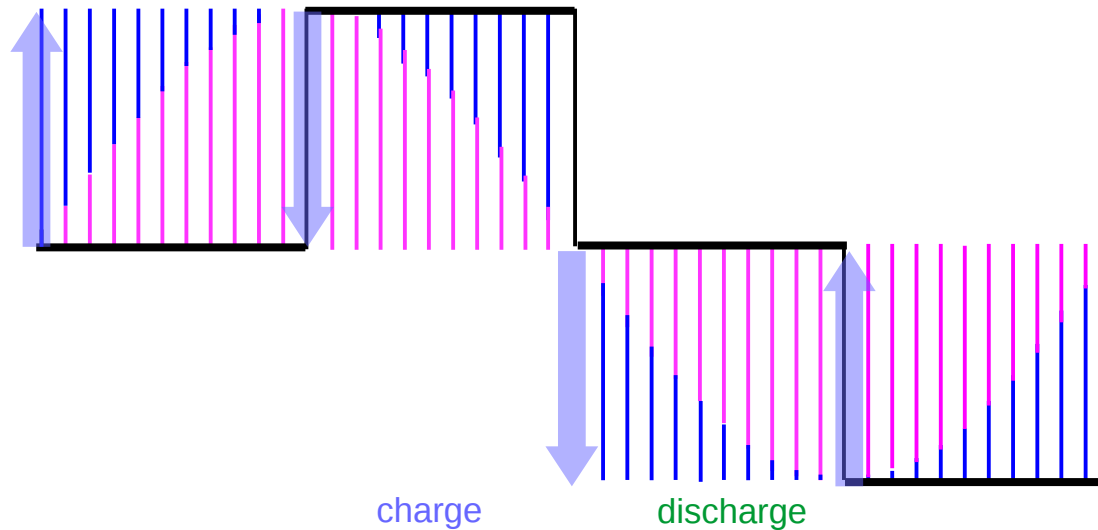

charge

discharge

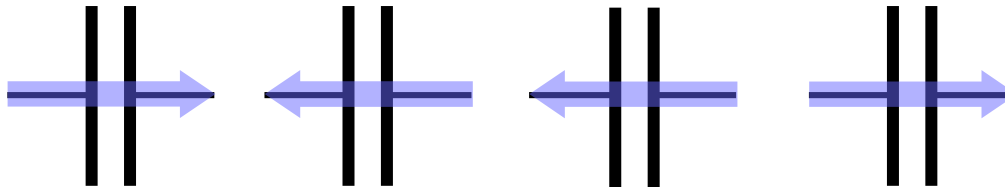

Everchanging signal pairs

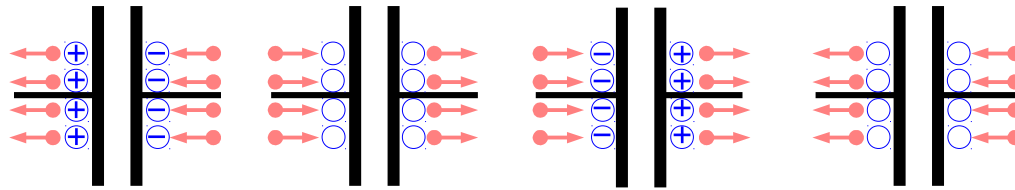

charge

discharge

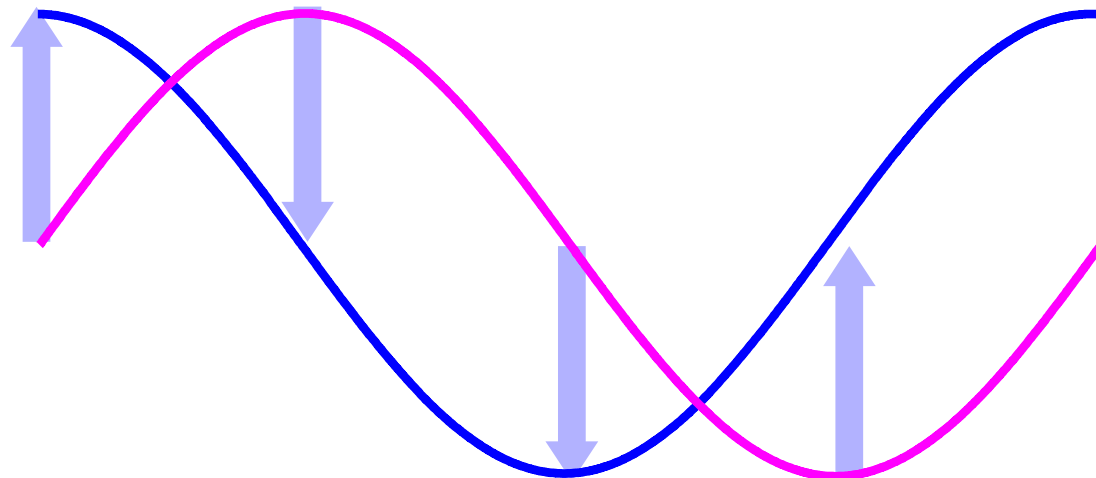

charge

discharge

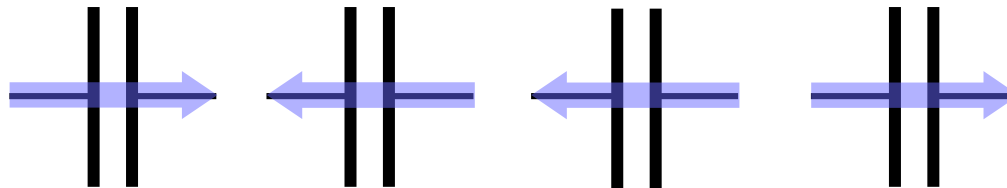

Everchanging signal pairs

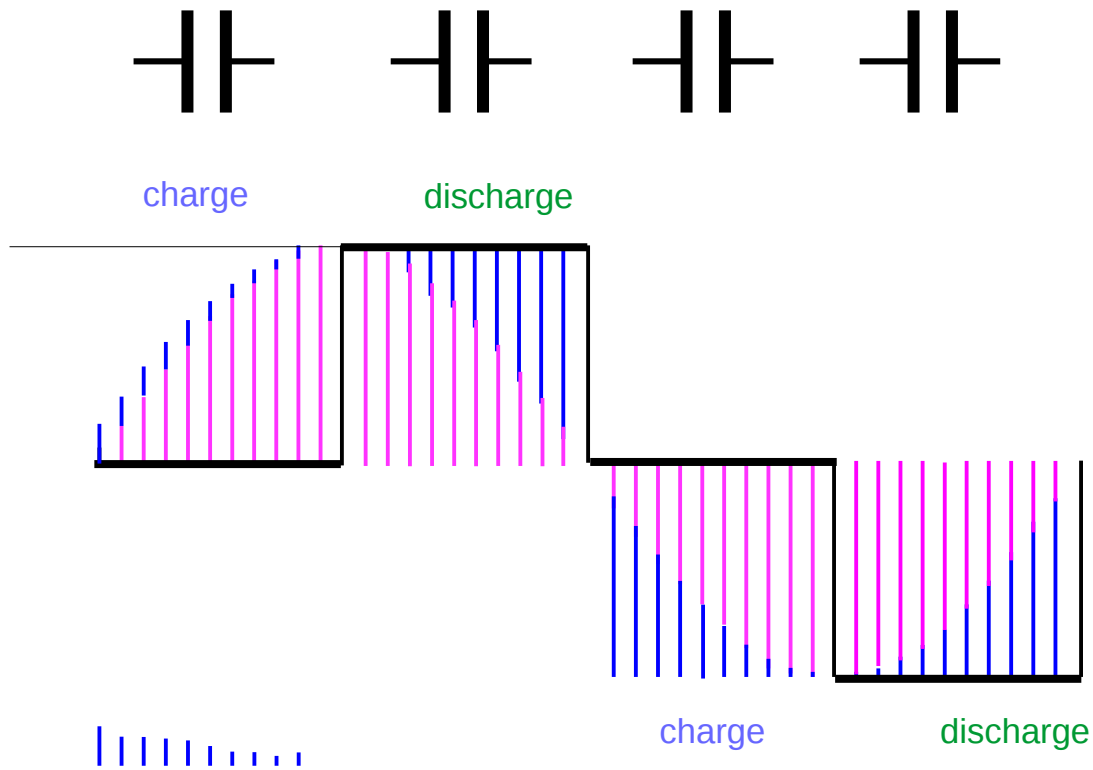

Everchanging signal pairs

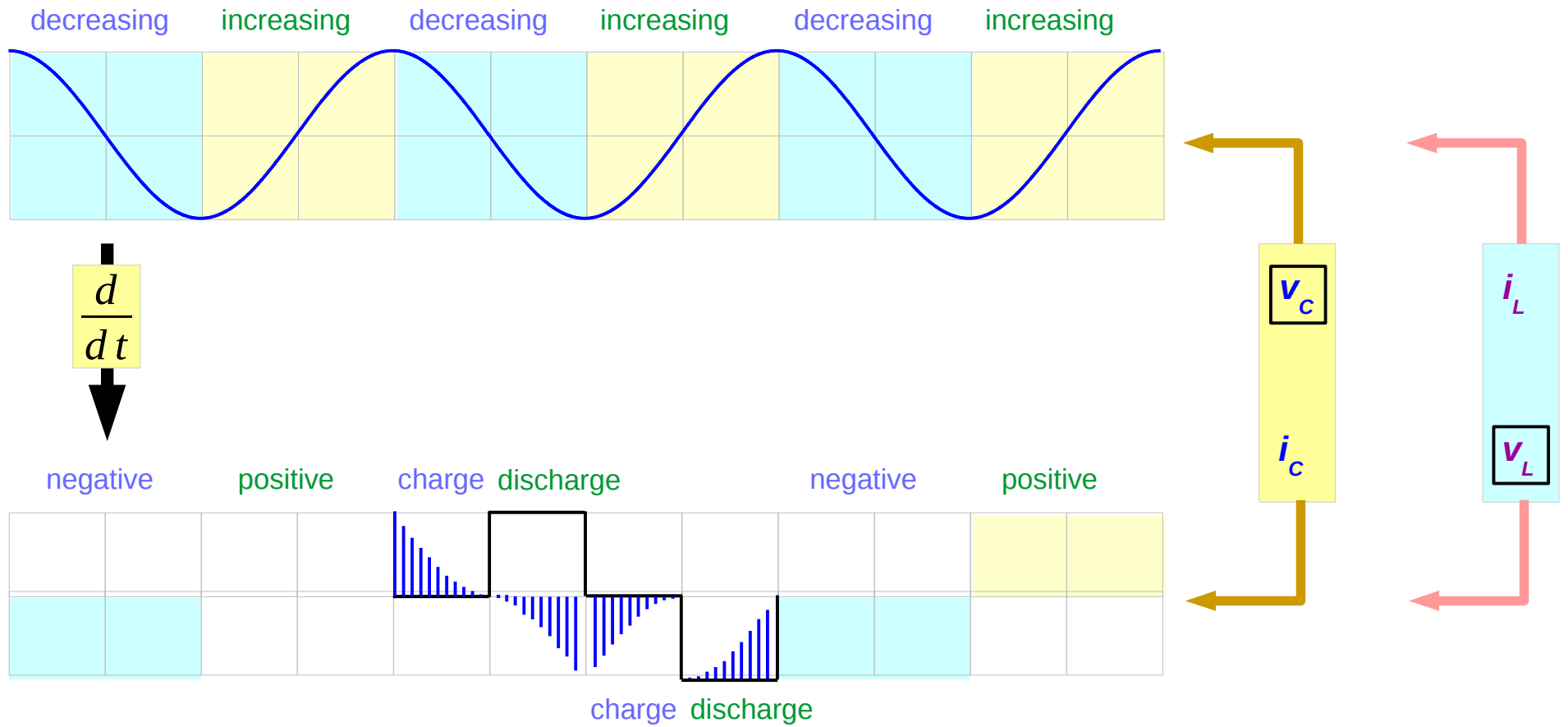

I leads V by 90°

Initial charge

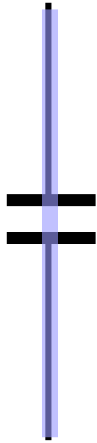

SHORT

V = 0

I : peak

Full charge

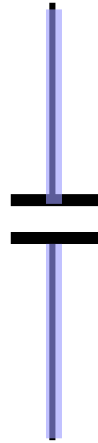

OPEN

I = 0

V : peak

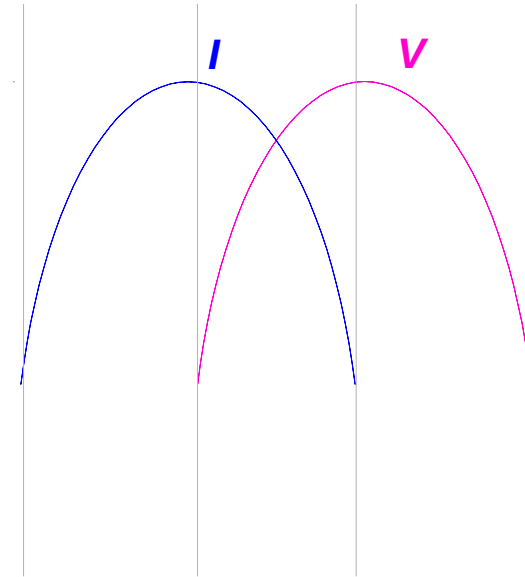

References

[1] <http://en.wikipedia.org/>

[2] J.H. McClellan, et al., Signal Processing First, Pearson Prentice Hall, 2003