

FPGA Carry Chain Adder (1A)

-
-

Copyright (c) 2010 -- 2021 Young W. Lim.

Permission is granted to copy, distribute and/or modify this document under the terms of the GNU Free Documentation License, Version 1.2 or any later version published by the Free Software Foundation; with no Invariant Sections, no Front-Cover Texts, and no Back-Cover Texts. A copy of the license is included in the section entitled "GNU Free Documentation License".

Please send corrections (or suggestions) to youngwlim@hotmail.com.

This document was produced by using OpenOffice and Octave.

FPGA Carry Chain Cell



$$s_i = (a_i \oplus b_i) \oplus c_i = p_i \oplus c_i$$

$$c_{i+1} = (a_i \cdot b_i) + (a_i \oplus b_i) c_i = \bar{p}_i \cdot g_i + p_i \cdot c_i = \bar{p}_i \cdot a_i + p_i \cdot c_i = \bar{p}_i \cdot b_i + p_i \cdot c_i$$

when $\bar{p}_i = 1$, then $a_i = b_i$

when $g_i = 1$, then $a_i = b_i = 1$

$p(i)$	0	1
0	0	1
1	1	0

$g(i)$	0	1
0	0	0
1	0	1

FPGA Carry Chain Cell



Synthesis of Arithmetic Circuits: FPGA, ASIC and Ebedded Systems, J-P Deschamps et al

FPGA Carry Chain

FPGAs generally contain dedicated computation resources for generating fast adders

The Virtex family programmable arrays include logic gates (**XOR**) and **multiplexers** that along with the general purpose **lookup tables** allow one to build effective carry-chain adders

The carry chain is made up of multiplexers belonging to adjacent configurable blocks

the lookup table is used for implementing the exclusive or function

$$p(i) = x(i) \text{ xor } y(i)$$

https://en.wikipedia.org/wiki/Carry-lookahead_adder

FPGA Carry Chain Cell

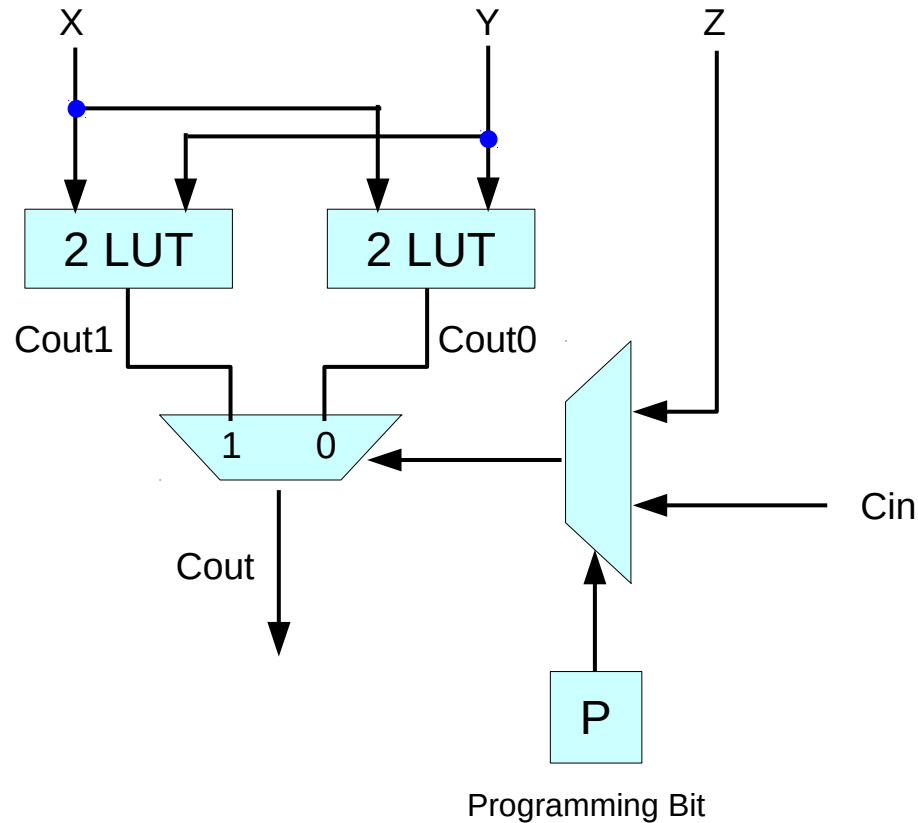

Cout1, Cout2 : functions of X, Y, Cin

Cout1 = X+Y when Cin=1

Cout0 = X Y when Cin=0

Cout = (X + Y) Cin + X Y $\overline{\text{Cin}}$

Cout = P' Cin + G $\overline{\text{Cin}}$... P' = relaxed P

Cout1	Cout0	Cout	Name
0	0	0	Kill
0	1	$\overline{\text{Cin}}$	Inverse Propagate
1	0	Cin	Propagate
1	1	1	Generate

High Performance Carry Chains for FPGAs, S. Hauck, M. M. Hosler, T. W. Fry

FPGA Carry Chain Cell

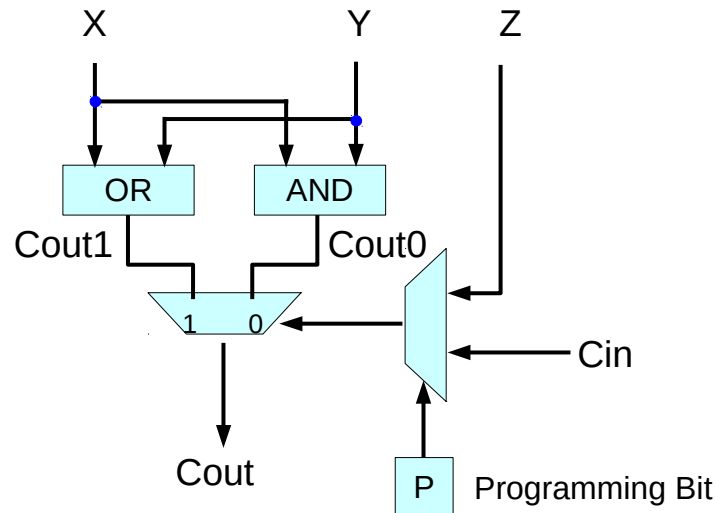

X	Y	Cin	$\overline{\text{Cin}}$	$\overline{X} \overline{Y}$
		Cout1	Cout0	
0	0	0	0	$\overline{X} \overline{Y}$
0	1	1	0	$\overline{X} Y$
1	0	1	0	$X \overline{Y}$
1	1	1	1	$X Y$

Cout : functions of X, Y, Cin

$$\text{Cout}(X, Y, 1) = \text{Cout1} = X + Y$$

$$\text{Cout}(X, Y, 0) = \text{Cout0} = X Y$$

$$\text{Cout1} = X + Y \text{ when Cin}=1$$

$$\text{Cout0} = X Y \text{ when Cin}=0$$

$$\text{Cout1} = P' \text{Cin} \dots P' = \text{relaxed } P$$

$$\text{Cout0} = G \overline{\text{Cin}}$$

If $\overline{\text{Cin}}$, then $\text{Cout} = (\overline{X} Y + X \overline{Y} + X Y)$
 If Cin , then $\text{Cout} = X Y$

$$\text{Cin} (X + Y) + \overline{\text{Cin}} X Y$$

$$\text{Cin} (\overline{X} Y + X \overline{Y} + X Y) + \overline{\text{Cin}} X Y$$

$$\text{Cin} (\overline{X} Y + X \overline{Y}) + (\text{Cin} + \overline{\text{Cin}}) X Y$$

$$P \text{Cin} + G$$

$$\text{Cin} (X + Y) + \overline{\text{Cin}} X Y$$

$$\text{Cin } P' + \overline{\text{Cin}} G$$

... P' : relaxed P

High Performance Carry Chains for FPGAs, S. Hauck, M. M. Hosler, T. W. Fry

FPGA Carry Chain Cell

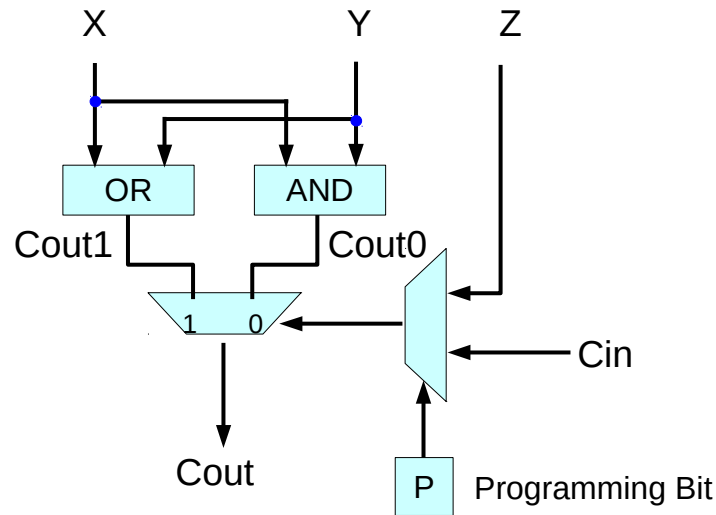

X	Y	Cin	$\overline{\text{Cin}}$	$\overline{X} \overline{Y}$
		Cout1	Cout0	
0	0	0	0	$\overline{X} \overline{Y}$
0	1	1	0	$\overline{X} Y$
1	0	1	0	$X \overline{Y}$
1	1	1	1	$X Y$

X	Y	Cin	Cout
0	0	0	Cout0
0	1	0	Cout0
1	0	0	Cout0
1	1	0	Cout0
0	0	1	Cout1
0	1	1	Cout1
1	0	1	Cout1
1	1	1	Cout1

High Performance Carry Chains for FPGAs, S. Hauck, M. M. Hosler, T. W. Fry

FPGA Carry Chain Cell

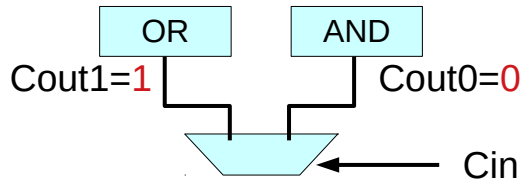

Cout1=1 when Cin=1
 Cout0=0 when Cin=0
 Cout = Cin

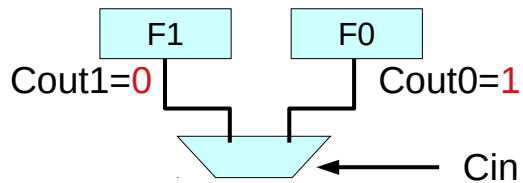

Cout1=0 when Cin=1
 Cout0=1 when Cin=0
 Cout = $\overline{\text{Cin}}$

Cout0	Cout1	Cout	Name
0	0	0	Kill
0	1	$\overline{\text{Cin}}$	Inverse Propagate
1	0	Cin	Propagate
1	1	1	Generate

Cout1	Cout0	Cout	Name
0	0	0	Kill
0	1	$\overline{\text{Cin}}$	Inverse Propagate
1	0	Cin	Propagate
1	1	1	Generate

High Performance Carry Chains for FPGAs, S. Hauck, M. M. Hosler, T. W. Fry

FPGA Carry Chain Cell

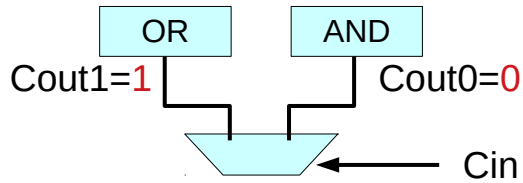

Cout1=1 when Cin=1
 Cout0=0 when Cin=0
 Cout = Cin

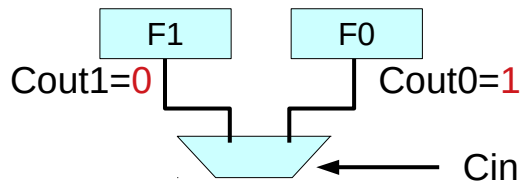

Cout1=0 when Cin=1
 Cout0=1 when Cin=0
 Cout = $\overline{\text{Cin}}$

Cout0	Cout1	Cout	Name
0	0	0	Kill
0	1	$\overline{\text{Cin}}$	Propagate
1	0	$\overline{\text{Cin}}$	Inverse Propagate
1	1	1	Generate

X	Y	Cin	Cout		Cout1	Cout0
0	0	0	0	Cout0	0	0
0	1	0	0	Cout0	1	0
1	0	0	0	Cout0	1	0
1	1	0	1	Cout0	1	1
0	0	1	0	Cout1	0	0
0	1	1	1	Cout1	1	0
1	0	1	1	Cout1	1	0
1	1	1	1	Cout1	1	1

High Performance Carry Chains for FPGAs, S. Hauck, M. M. Hosler, T. W. Fry

Carry Chain

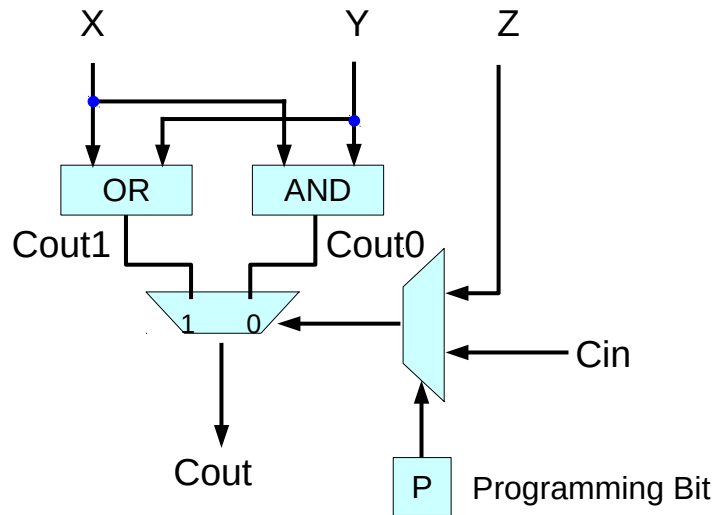

Carry Out

X	Y	Cin	Cout
0	0	Cin	$\overline{\text{Cin}}$
0	1	Cin	$\overline{\text{Cin}}$
1	0	Cin	$\overline{\text{Cin}}$
1	1	Cin	Cin

X	Y	Cin	$\overline{\text{Cin}}$	$\overline{X} \overline{Y}$
		Cout1	Cout0	
0	0	0	0	$\overline{X} \overline{Y}$
0	1	1	0	$\overline{X} Y$
1	0	1	0	$X \overline{Y}$
1	1	1	1	$X Y$

Cout1	Cout0	Cout	Name
0	0	0	Kill
0	1	$\overline{\text{Cin}}$	Inverse Propagate
1	0	Cin	Propagate
1	1	1	Generate

Cout1=1 when Cin=1

Cout0=0 when Cin=0

Cout = Cin propagate

Cout1=0 when Cin=1

Cout0=1 when Cin=0

Cout = $\overline{\text{Cin}}$ inverse propagate

Parity Checker

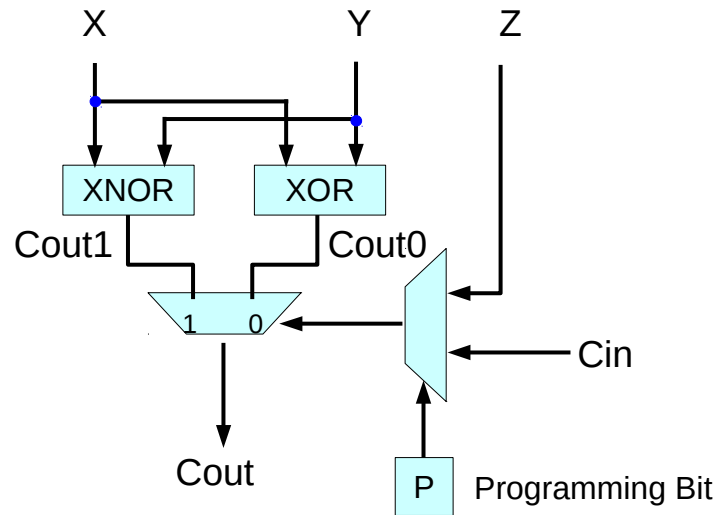

Computing Parity

$X \oplus Y \oplus C_{in}$	
$0 \oplus 0 \oplus C_{in}$	$\overline{C_{in}}$
$0 \oplus 1 \oplus C_{in}$	$\overline{C_{in}}$
$1 \oplus 0 \oplus C_{in}$	$\overline{C_{in}}$
$1 \oplus 1 \oplus C_{in}$	C_{in}

X	Y	Cin	$\overline{C_{in}}$	
		Cout1	Cout0	
0	0	1	0	$\overline{X} \overline{Y}$
0	1	0	1	$\overline{X} Y$
1	0	0	1	$X \overline{Y}$
1	1	1	0	$X Y$

Cout1	Cout0	Cout	Name
0	0	0	Kill
0	1	$\overline{C_{in}}$	Inverse Propagate
1	0	C_{in}	Propagate
1	1	1	Generate

Cout1=1 when Cin=1

Cout0=0 when Cin=0

Cout = Cin propagate

Cout1=0 when Cin=1

Cout0=1 when Cin=0

Cout = $\overline{C_{in}}$ inverse propagate

Ripple Carry Chain



the **first** cell in the chain

High Performance Carry Chains for FPGAs, S. Hauck, M. M. Hosler, T. W. Fry

FPGA Carry Chain Cell

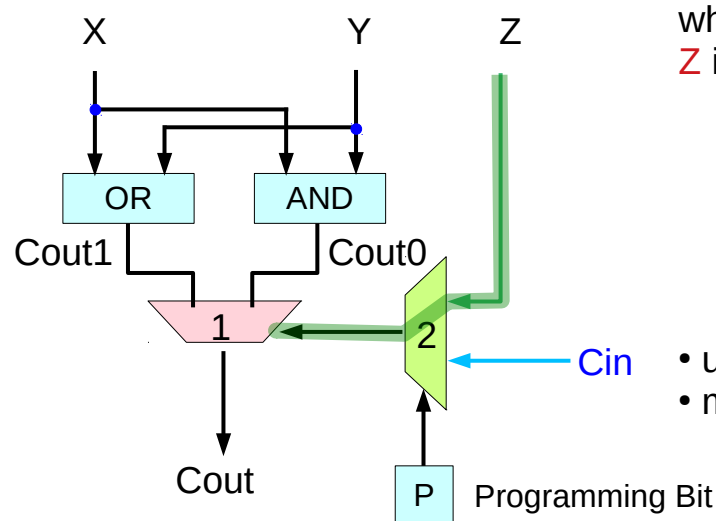

when **Cin** is ignored,
Z is routed to **mux1**

- used in **combined adder/subtractors**
- must be ignored, otherwise

the logic cells - resources to compute a function
the exact location of logic cells depends on the user.
a user can start or end a carry computation
at any place in an fpga.

But in many carry computations,
the first cell has only 2 inputs,
and forcing the carry chain
to wait for the arrival of an additional,
unnecessary input **Z** will only needlessly
slow down the circuit's computation.

High Performance Carry Chains for FPGAs, S. Hauck, M. M. Hosler, T. W. Fry

FPGA Carry Chain Cell

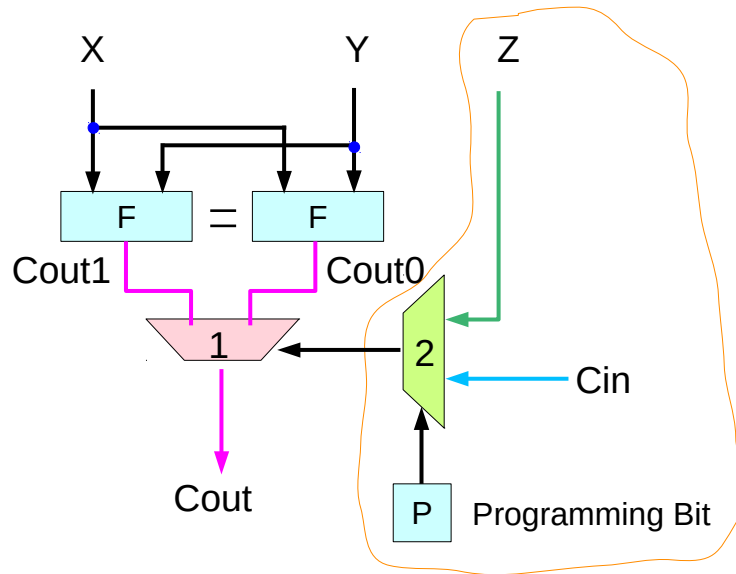

when **Cin** is ignored,
Z can also be ignored
by having the same LUTs

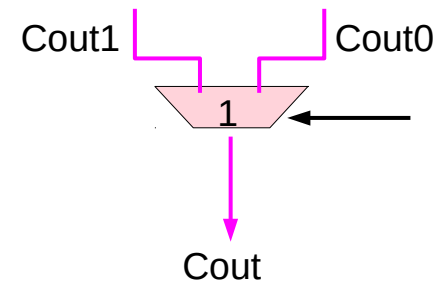

the **first cell** in the chain

the same LUTs

the same output
regardless of **Z** and **Cin**

$Cout1 = Cout0 = Cout$
regardless of the select

Ripple Carry Chain

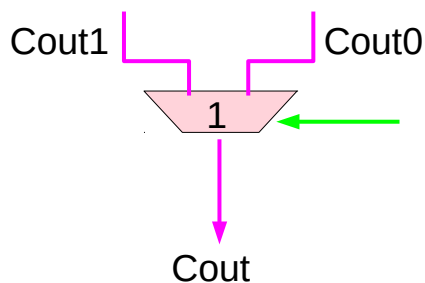
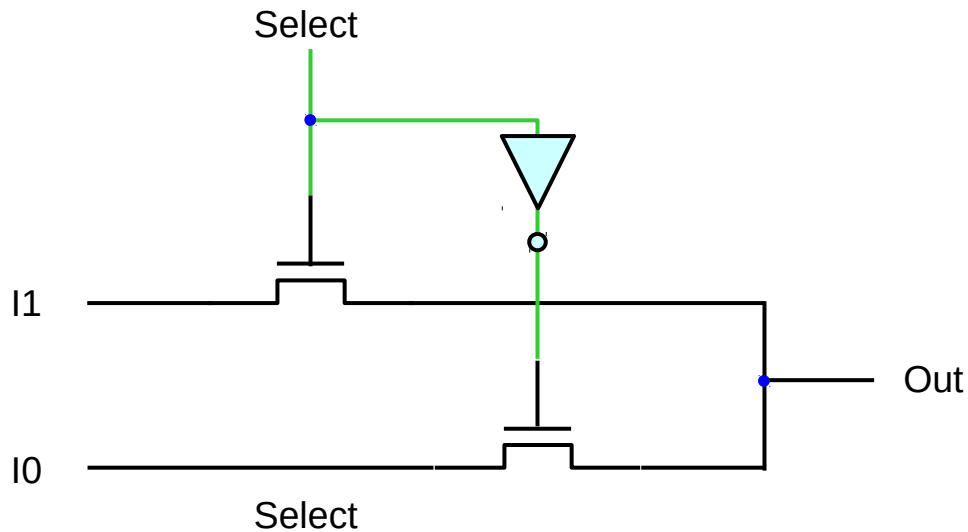

fig1b shows an implementation of a mux that does not obey this requirement

since the carry chain is part of an fpga, the input to this mux could be connected to some **unused logic** in another row which is generating **unknown values**.

if that unused logic had **multiple transitions** which caused the signal to change **quicker** than the gate could react, then it is possible that **the select signal** to this mux could be stuck midway between true and false (2.5V for 5V CMOS)

in this case, it will not be able to pass a true value from the input to the output and thus will not function properly for this application.

Ripple Carry Chain

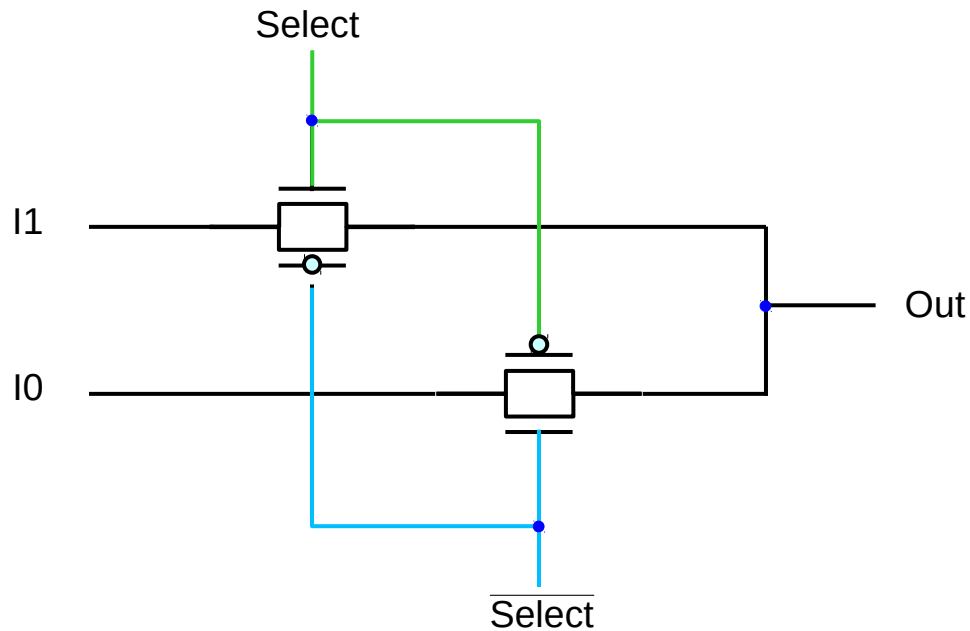

however a mux built with both n-transistor and p-transistor pass gates will operate properly for this case

assume this mux implementation will be used

tristate driver based muxes could be used, which restore signal drive and cut series RC chains

Unit Gate Delay Model

All simple gate of two or three inputs that are directly implementable in **one logic level** in CMOS are considered to have a **delay of one**.

All other gate must be implemented by such gates, and have the delay of the underlying circuit.

Delay of one

- inverters and
- 2 to 3 input NAND
- 2 to 3 input NOR gates

A **2:1 mux** has a **delay of one** from the I0 or I1 inputs to the output, But has a **delay of two** from the select input to the output due to the Inverter delay

Delay of zero (constant delay)

- the delay of the 2-LUTs,
- any routing leading to them,

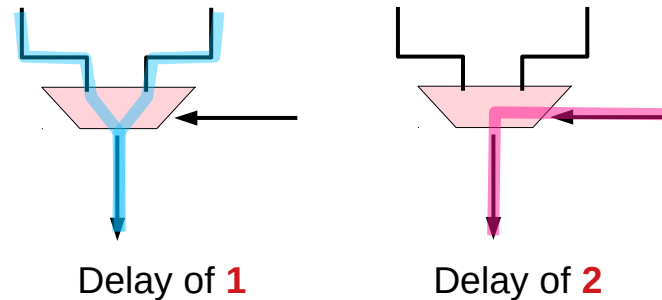
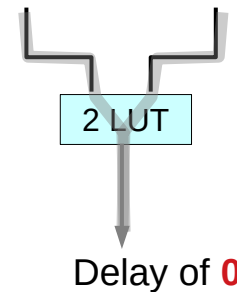

FPGA Carry Chain Cell

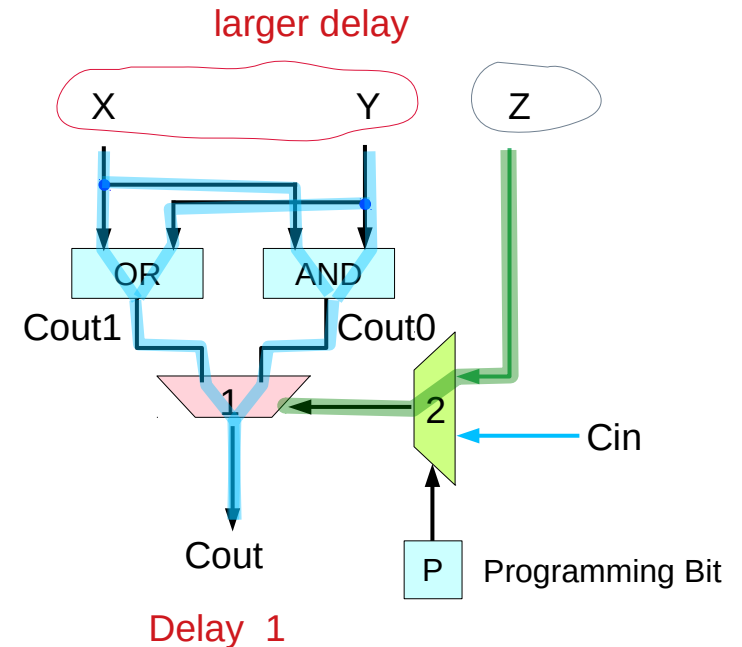
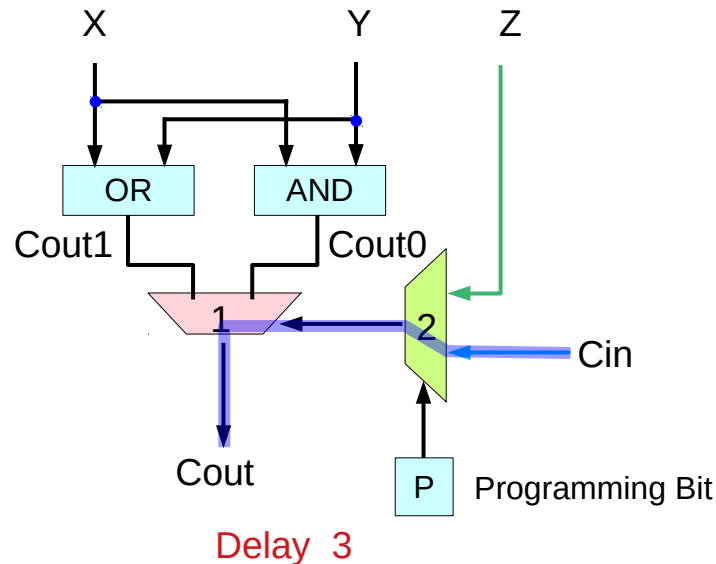

Significantly slower
 two muxes on the carry chain in each cell

Delay 1 for first cell
 Delay 3 for each additional cell in the carry chain
 delay 1 for mux2
 delays 2 for mux1

Overall $3n-2$ for an n-cell carry chain

The critical path comes from the 2-LUTs
 and not from the input Z
 since the delay through the 2-LUTs
 will be larger than through mux 2 in the first cell

FPGA Carry Chain Cell

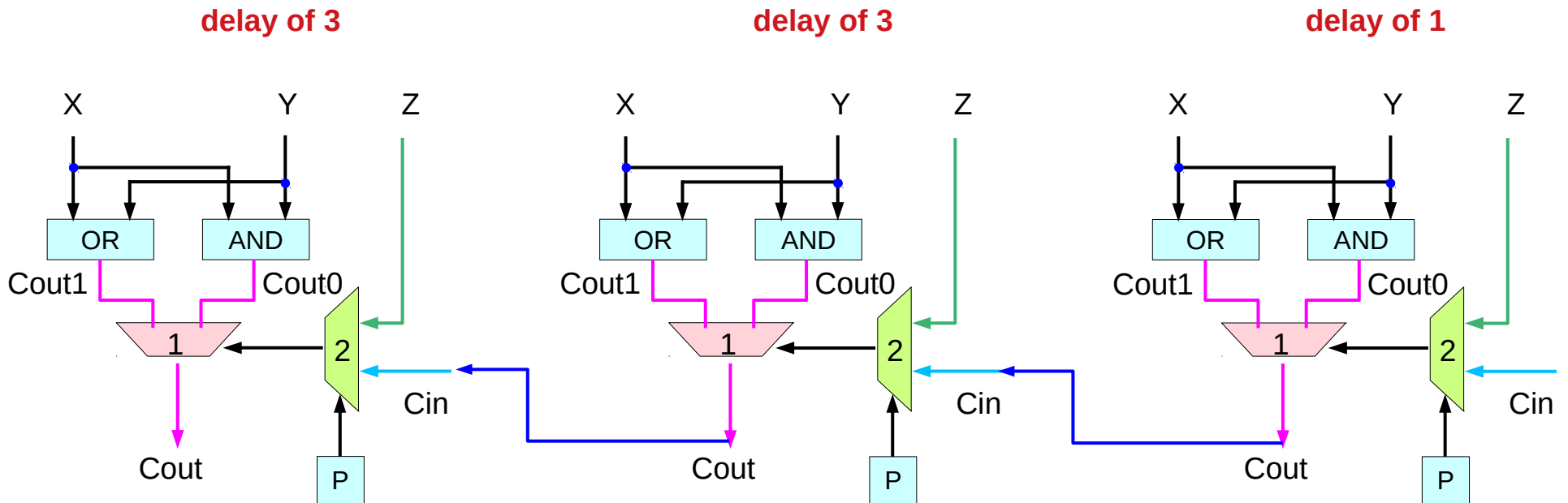

delay of $3n-2$ for an n -bit ripple carry chain

High Performance Carry Chains for FPGAs, S. Hauck, M. M. Hosler, T. W. Fry

FPGA Carry Chain Cell

the linear delay growth of ripple carry adders

optimize a ripple carry chain structure for use in FPGAs

while this provides some performance gain
over the basic ripple carry scheme
found in many current FPGAs,

still much slower than what is done in custom logic

advanced adder techniques in custom logic
can be integrated into reconfigurable logic

High Performance Carry Chains for FPGAs, S. Hauck, M. M. Hosler, T. W. Fry

FPGA Carry Chain Cell

Design A

$2n / 2n+2$

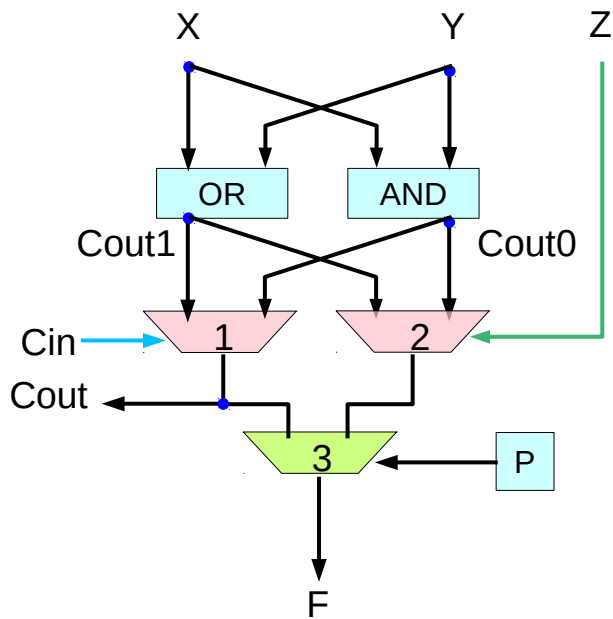

Design B

$2n / 2n+1$

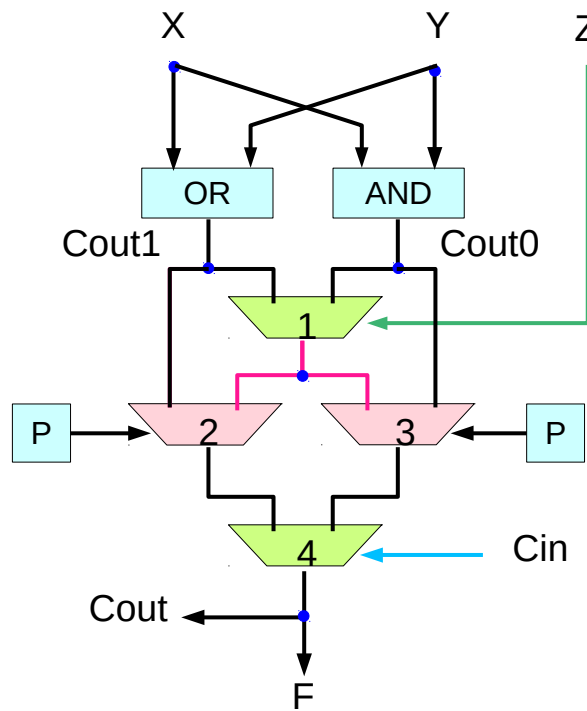

Design C

$2n+2$

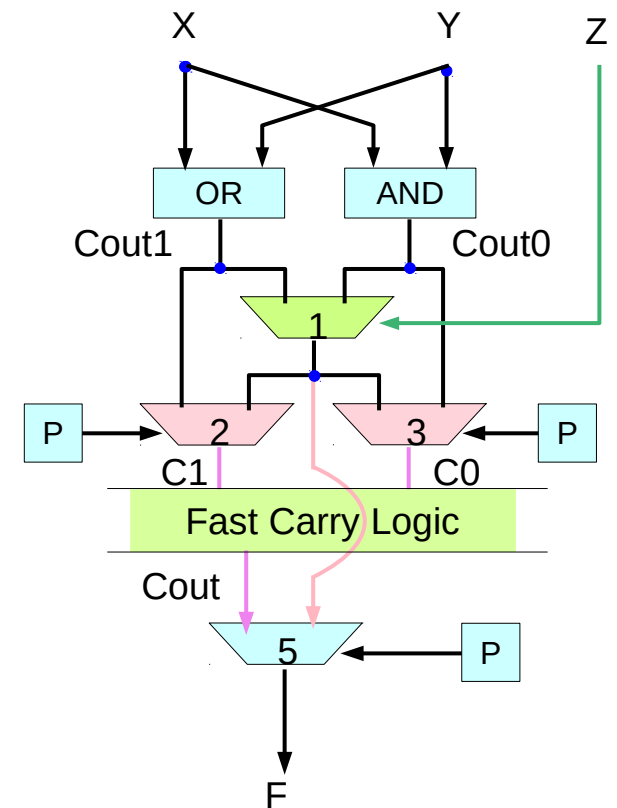

High Performance Carry Chains for FPGAs, S. Hauck, M. M. Hosler, T. W. Fry

Design A (1)

to reduce the delay of the ripple carry chain

- remove **mux2** from the carry path.
- no need to choose between **Cin** and **Z** for the select line to the output **mux1**

- two separate muxes, **mux1** and **mux2**, controlled by **Cin** and **Z**, respectively.
- the circuit chooses between these outputs with **mux3**.

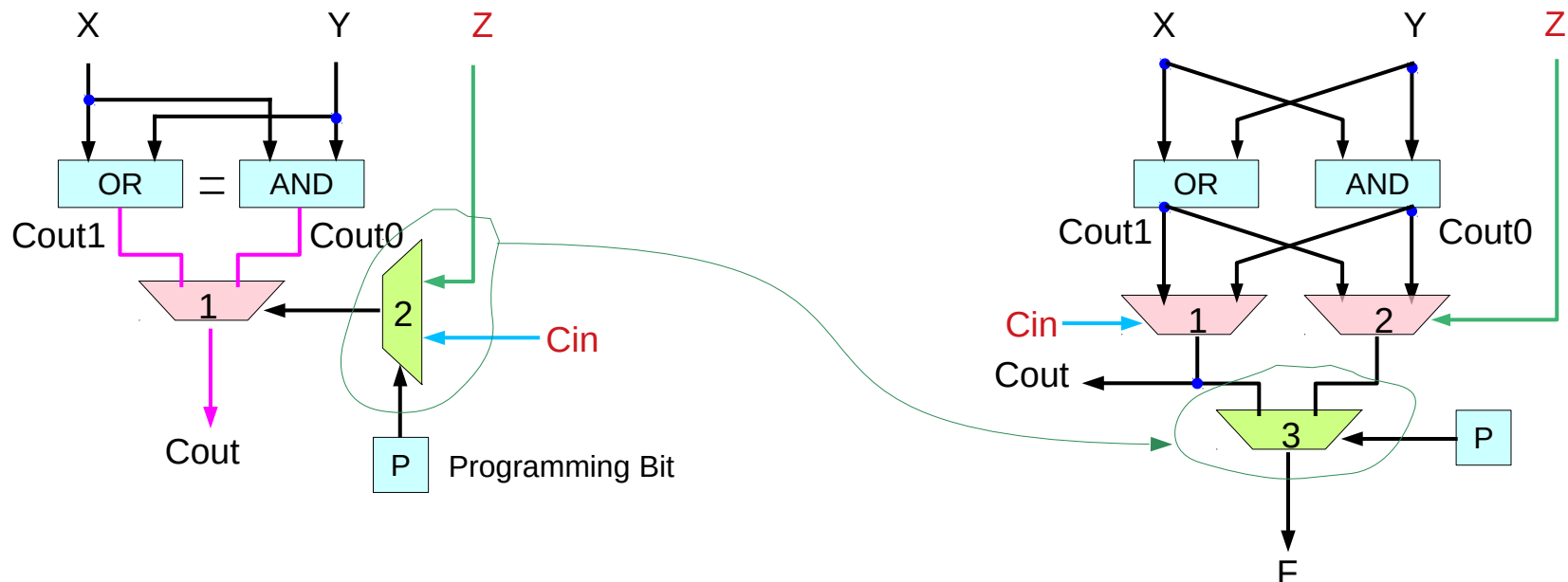

High Performance Carry Chains for FPGAs, S. Hauck, M. M. Hosler, T. W. Fry

Design A (2)

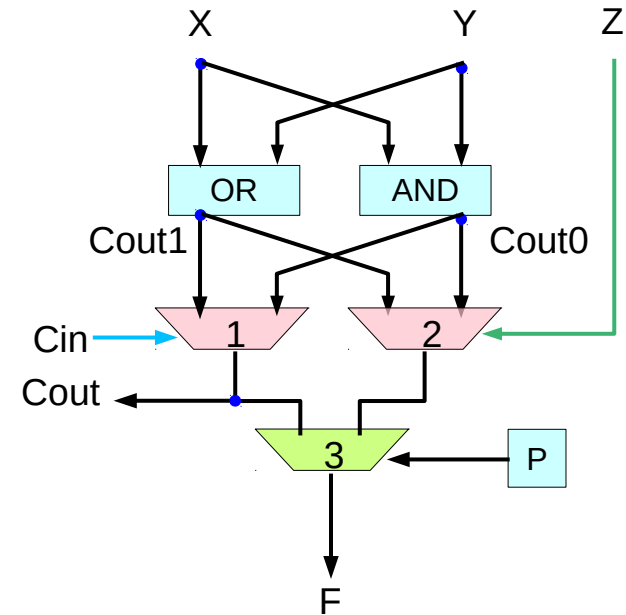
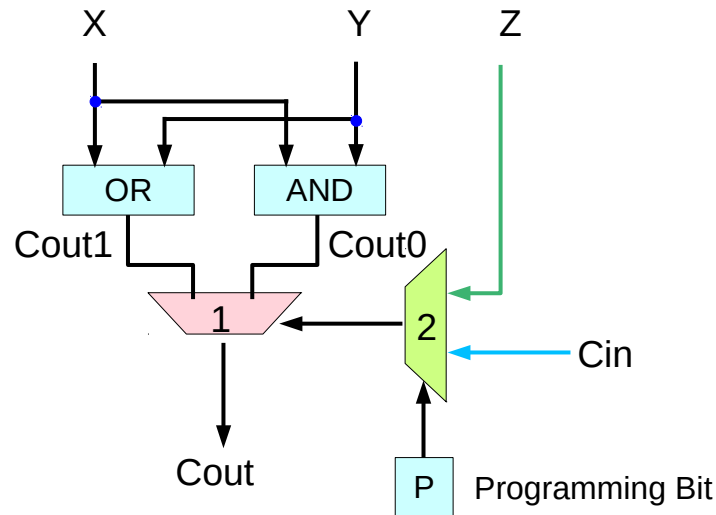

- not logically equivalent
- the **Z** input in the first cell cannot be used
 - **Z** is only attached to **mux2**
 - **mux2** does not lead to the carry cells
 - not connected to **Cout**

High Performance Carry Chains for FPGAs, S. Hauck, M. M. Hosler, T. W. Fry

Design A (3)

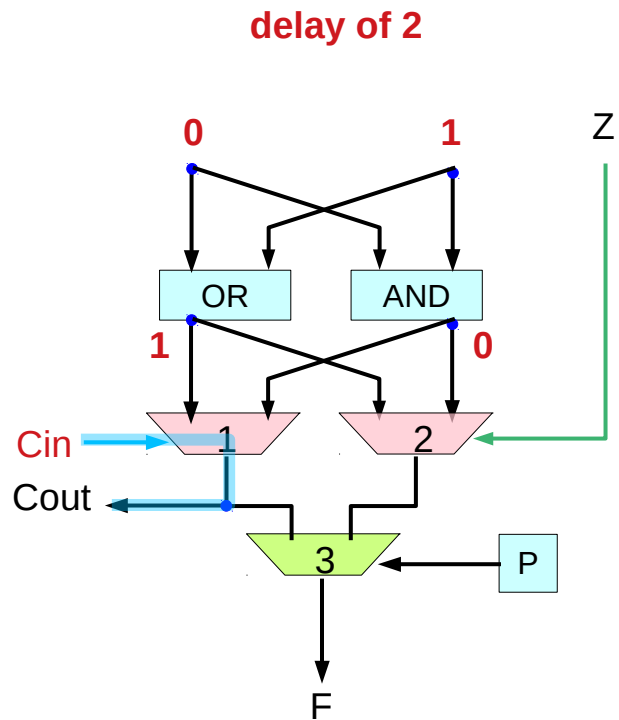

an additional cell
for generating Cin

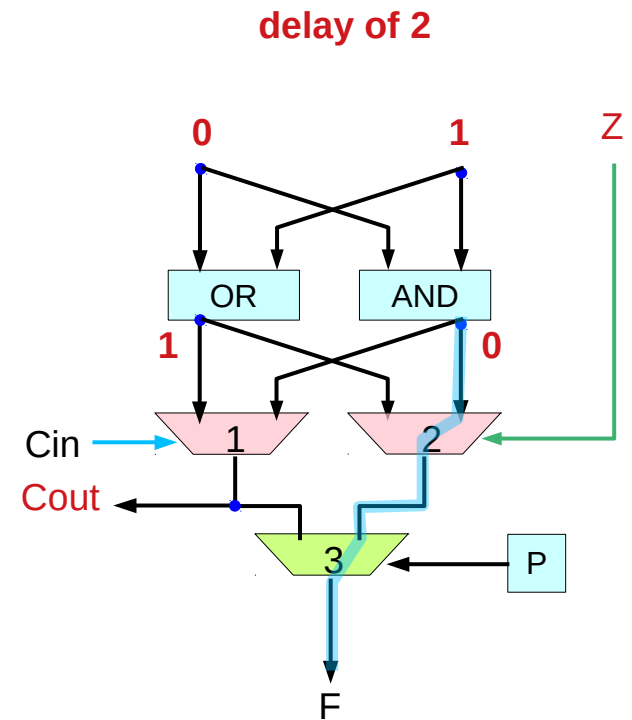

- need an additional cell to use Z as a carry input

Design A (4)

delay of 3

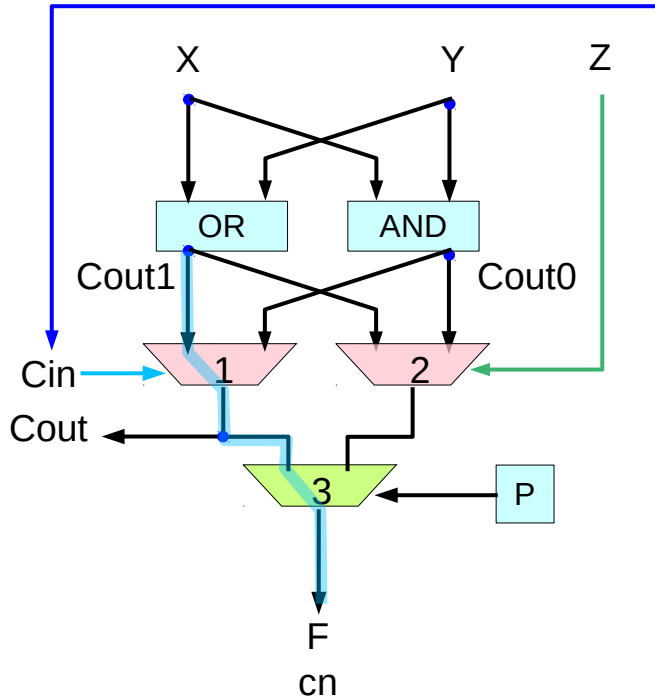

(2 for mux1, 1 for mux3)

delay of 2

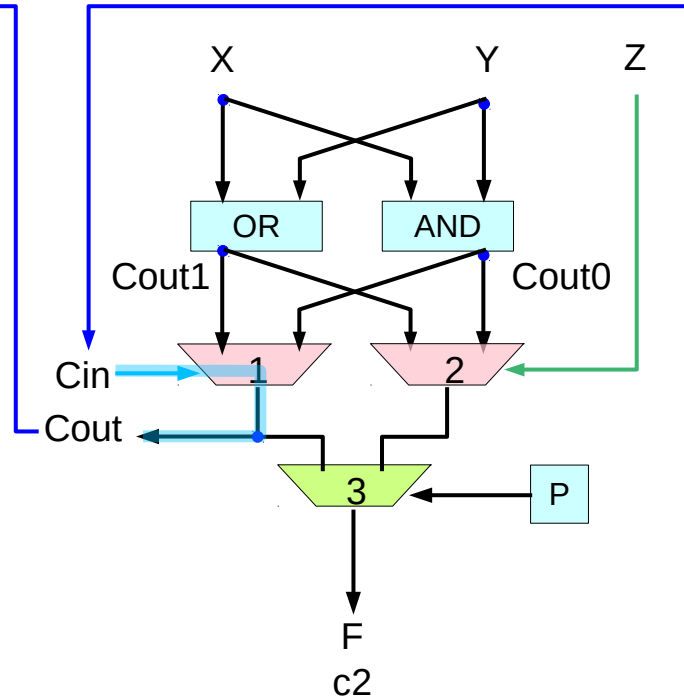

50% faster circuit than the original design

delay of $2n$ for an n -bit ripple carry chain

delay of $2(n+1)$

the first cell

delay of 1

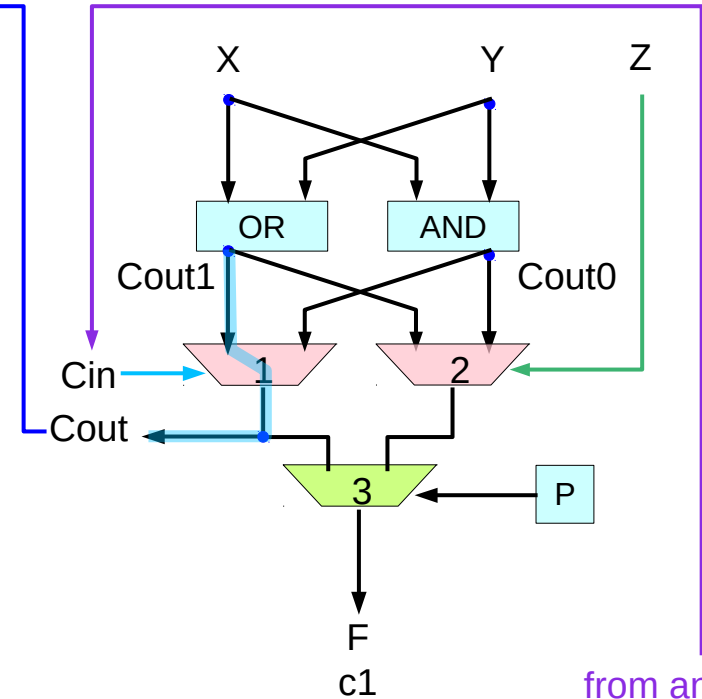

from an additional cell

without a carry input Z

with a carry input Z

Design A (5)

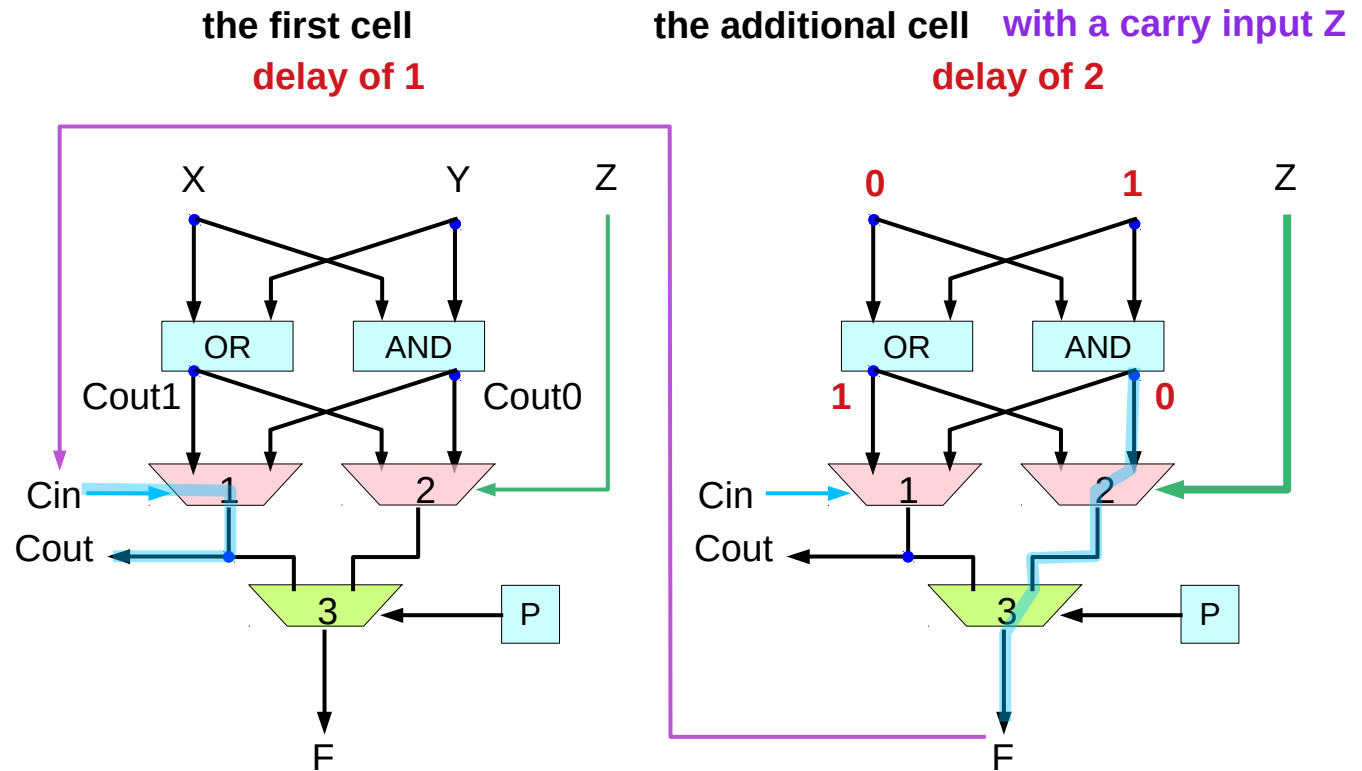

delay of $2(n+1)$ for an n -bit ripple carry chain with a carry input

Design B (1)

although this design is 1 gate delay slower than that of fig 2a, it provides the ability to have a **carry input** to the **first cell** in a **carry chain**, something that is important in many computations.

Also, for carry computations that do not need this feature, without a **carry input** the first cell in a **carry chain** built from fig 2b can be configured to bypass **mux1**, reducing the overall delay to $2n$, which is identical to that of fig2a.

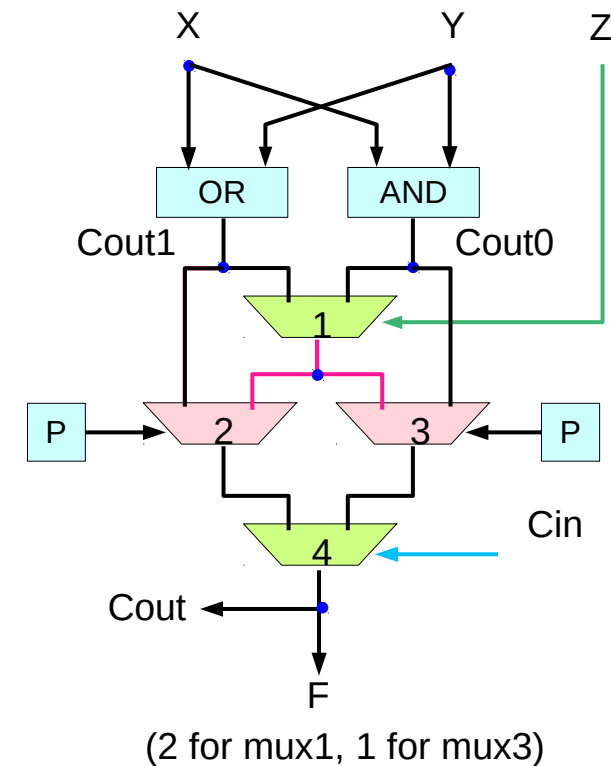

Design B (2)

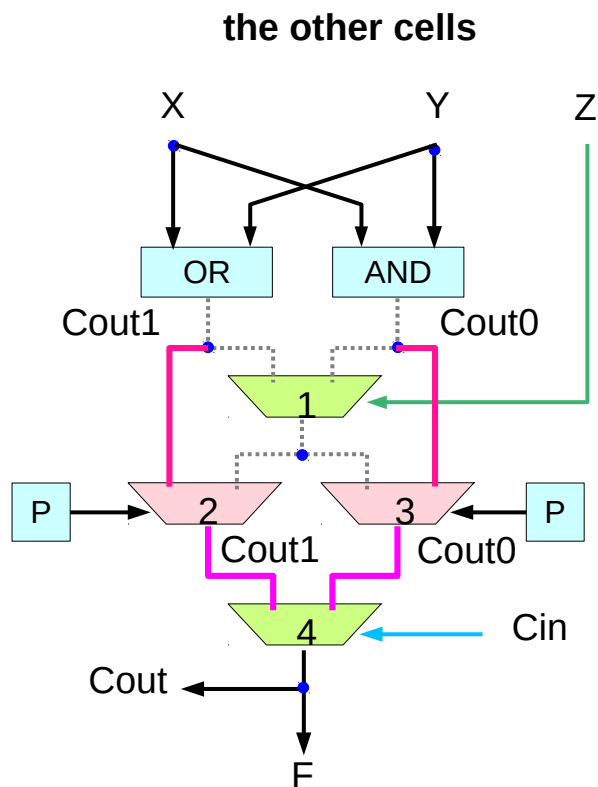

for cells in the middle of a carry chain
 mux2 passes Cout1
 mux3 passes Cout0
 mux4 receives Cout1 and Cout0
 provides a standard ripple carry path.

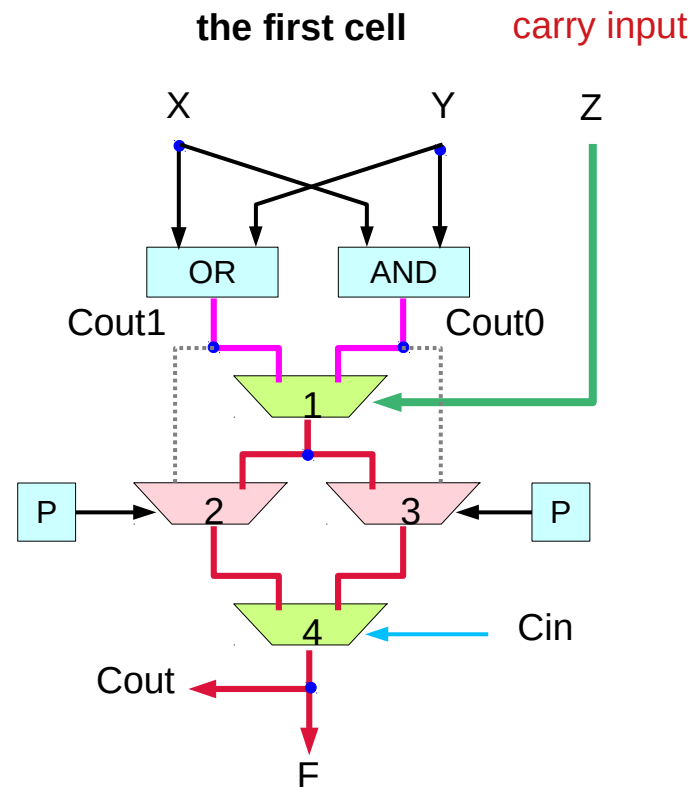

For the first cell in a carry chain
 with a carry input (provided by input Z),
 mux2 and mux3 both pass the value from mux1

the two main inputs to mux4 are identical
 the output of mux4 (Cout) will be the same
 as the output of mux1 (ignoring Cin)

High Performance Carry Chains for FPGAs, S. Hauck, M. M. Hosler, T. W. Fry

Design B (3)

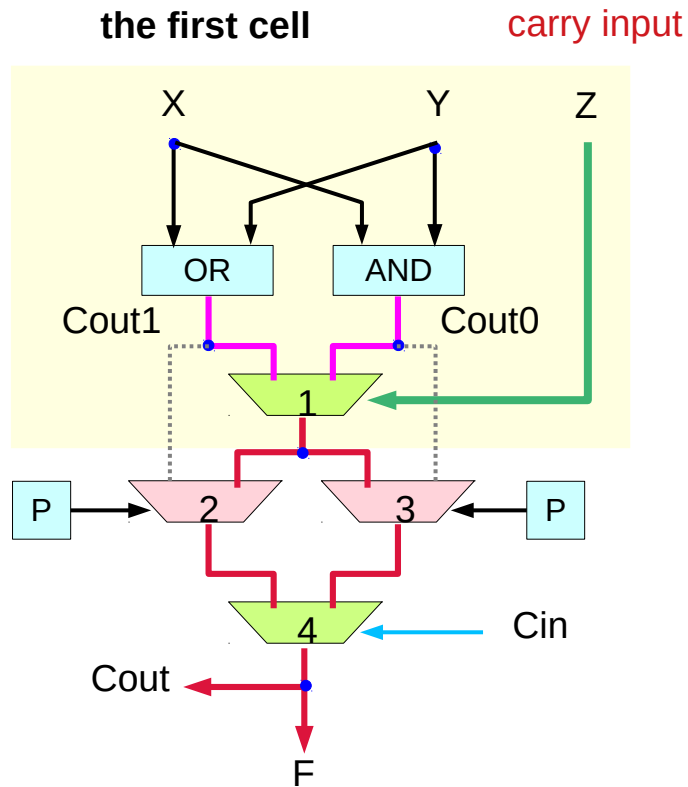

mux1's main inputs are driven by two 2-LUTs (OR, AND) controlled by **X** and **Y**
mux1 forms a **3-LUT** with the other 2-LUTs

When **mux2** and **mux3** pass the value from **mux1** (**Cout1** and **Cout2** respectively)
the circuit is configured to continue the carry chain

Functionally equivalent

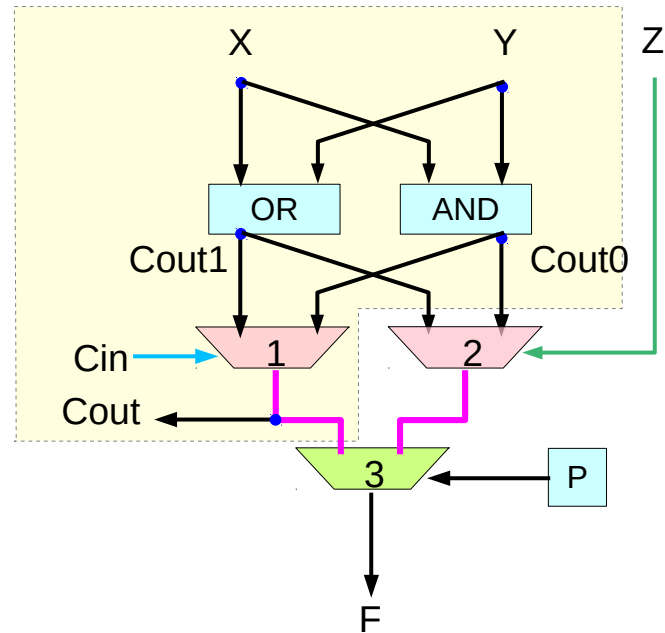

High Performance Carry Chains for FPGAs, S. Hauck, M. M. Hosler, T. W. Fry

Design B (4)

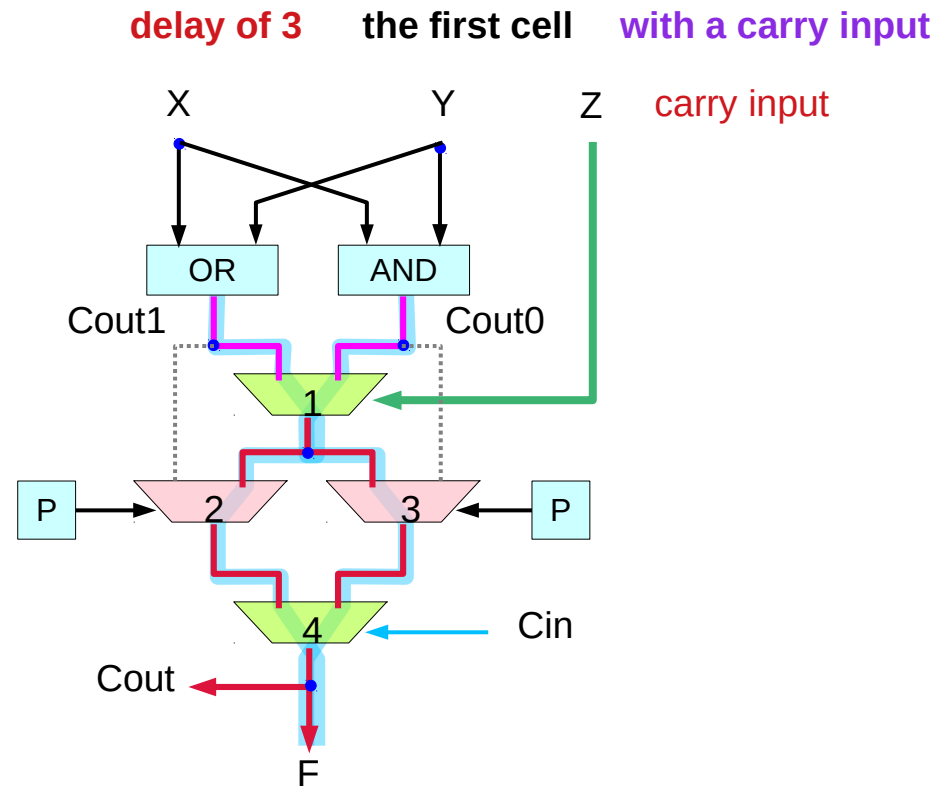
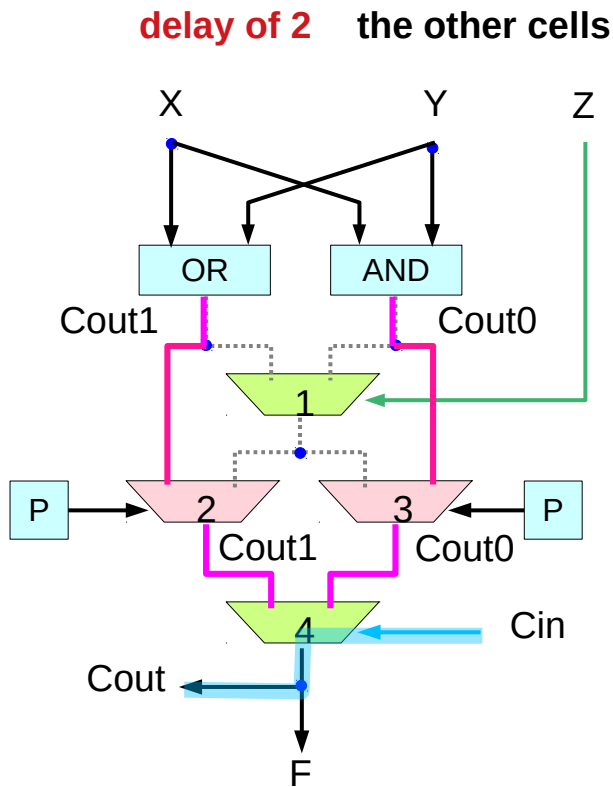

A delay of 2 in all other cells
except the first cell in the carry chain

a delay of 3 in the first cell
 1 in mux1, 1 in mux2, 1 in mux4

an total delay of $2n+1$ for an n-bit carry chain
 when a carry input to the first cell is enabled

1 gate delay slower than that of fig 2a,

High Performance Carry Chains for FPGAs, S. Hauck, M. M. Hosler, T. W. Fry

Design B (5)

delay of 2 the other cells

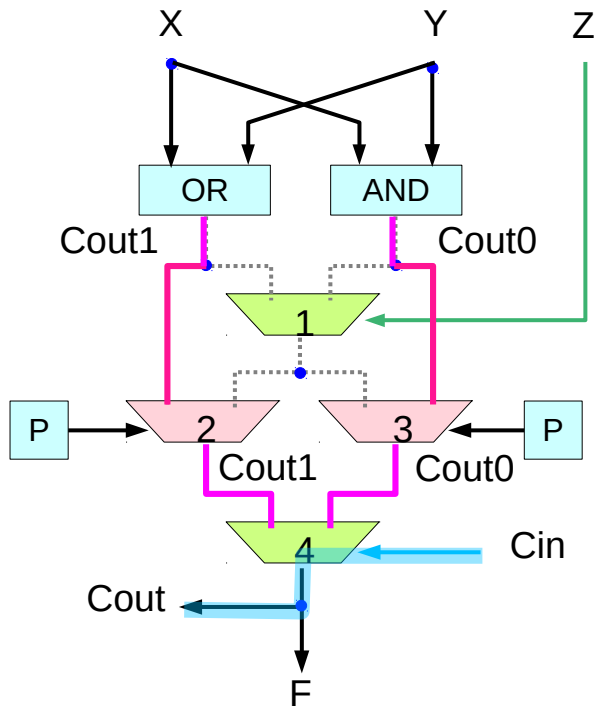

A delay of 2 in all other cells
except the first cell in the carry chain

an total delay of **2n** for an n-bit carry chain
when a carry input to the first cell is **disabled**

delay of 2 the first cell without a carry input

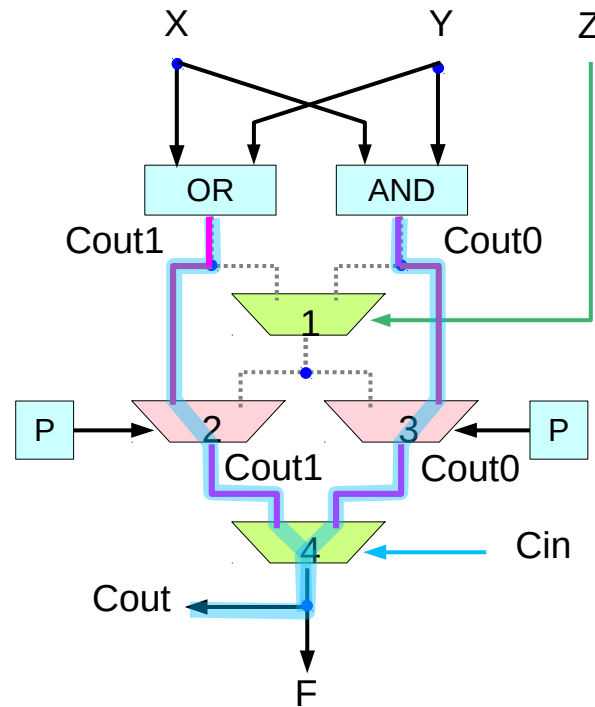

a delay of 2 in the first cell
when a carry input is not used

High Performance Carry Chains for FPGAs, S. Hauck, M. M. Hosler, T. W. Fry

Design B (6)

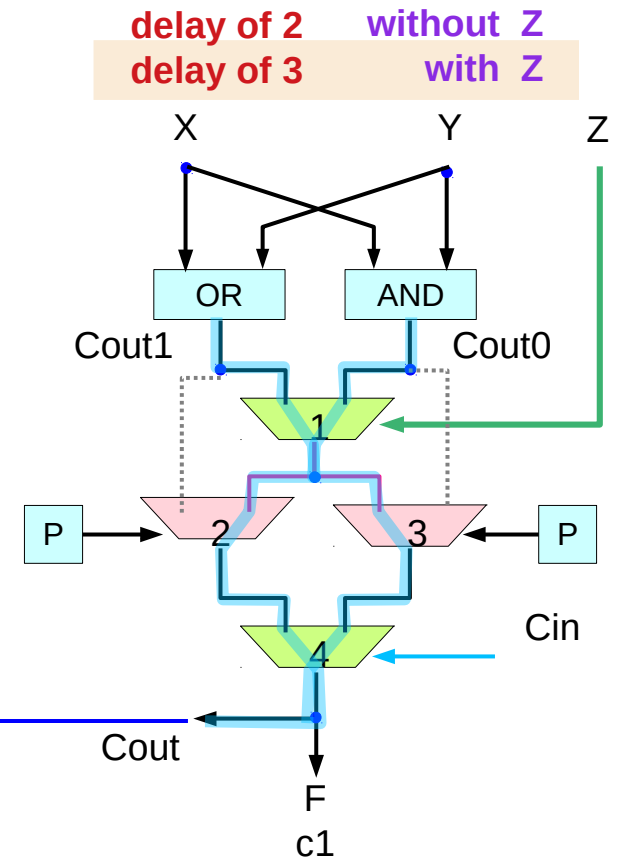
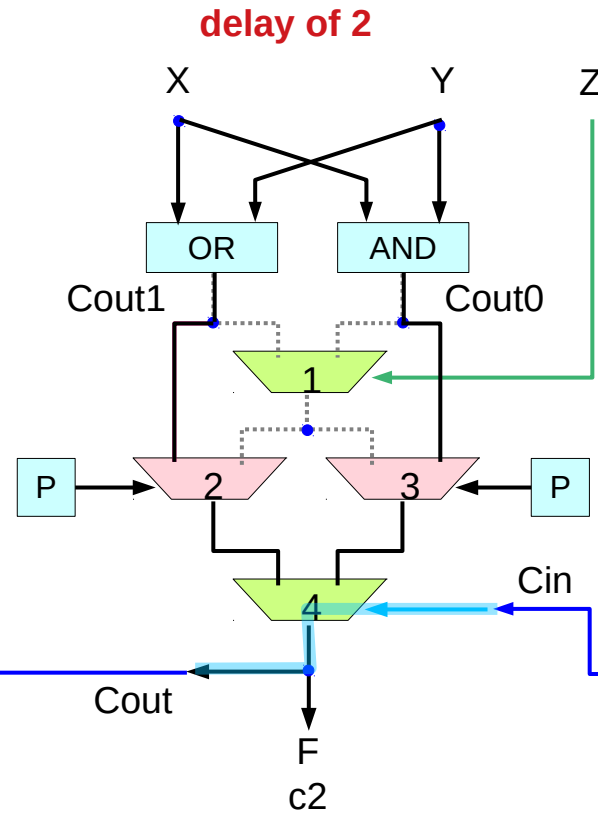
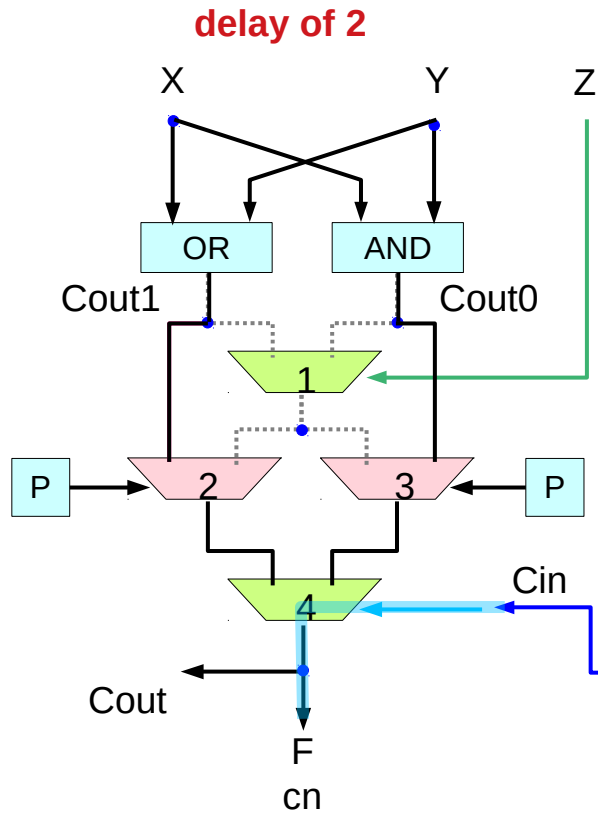

delay of $2n$ for an n -bit ripple carry chain

without a carry input Z

delay of $2n+1$

with a carry input Z

High Performance Carry Chains for FPGAs, S. Hauck, M. M. Hosler, T. W. Fry

Design B (7)

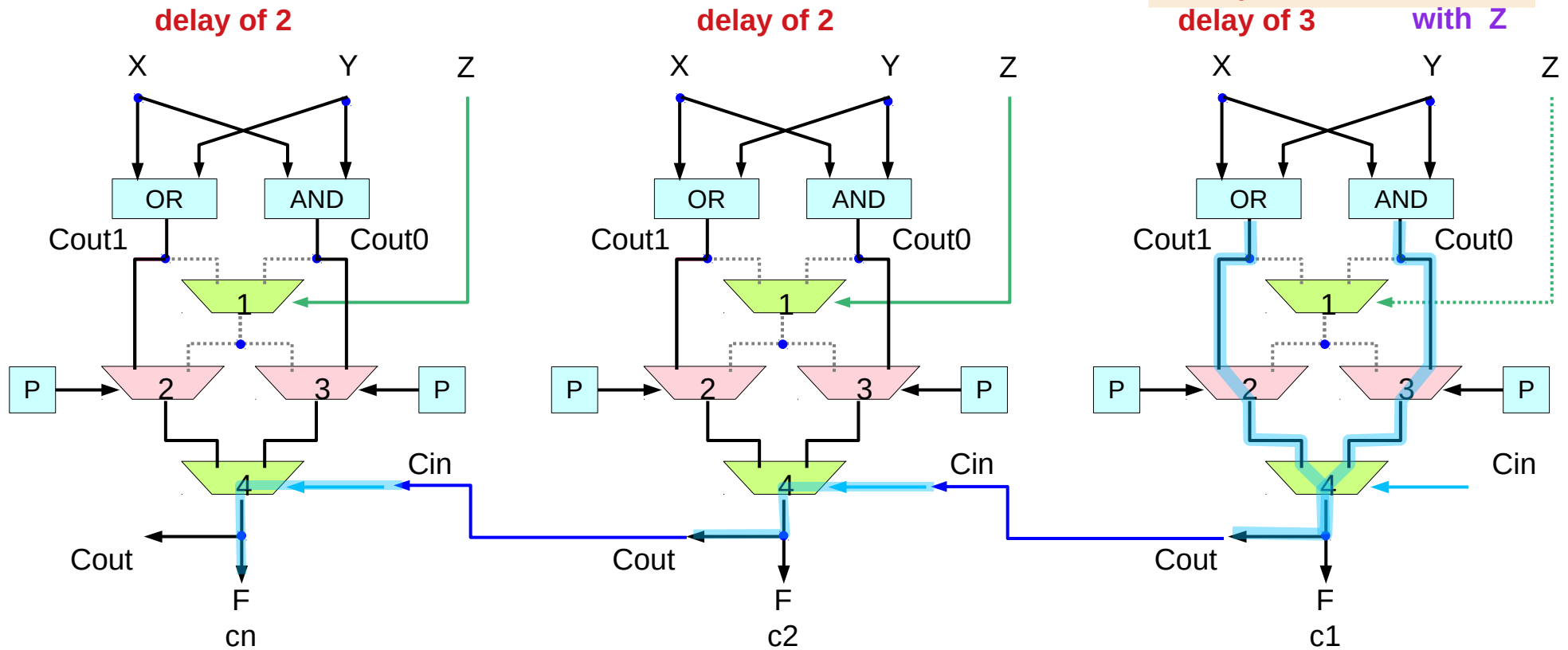

delay of $2n$ for an n -bit ripple carry chain

without a carry input Z

delay of $2n+1$

with a carry input Z

High Performance Carry Chains for FPGAs, S. Hauck, M. M. Hosler, T. W. Fry

Design C (1)

the actual carry chain (mux4) in Design B has been replaced by

- an **abstract fast carry logic unit**
- **mux5** has been added

to the **abstract fast carry logic units**, various high performance carry chains can be applied

mux5 is present because

- significant delay for **non-carry computations**
- much faster **carry propagation** for long carry chains

when used as a simple normal **3 LUT**, using inputs X, Y, and Z
mux5 allows us to bypass the carry chain by selecting the output of **mux1**

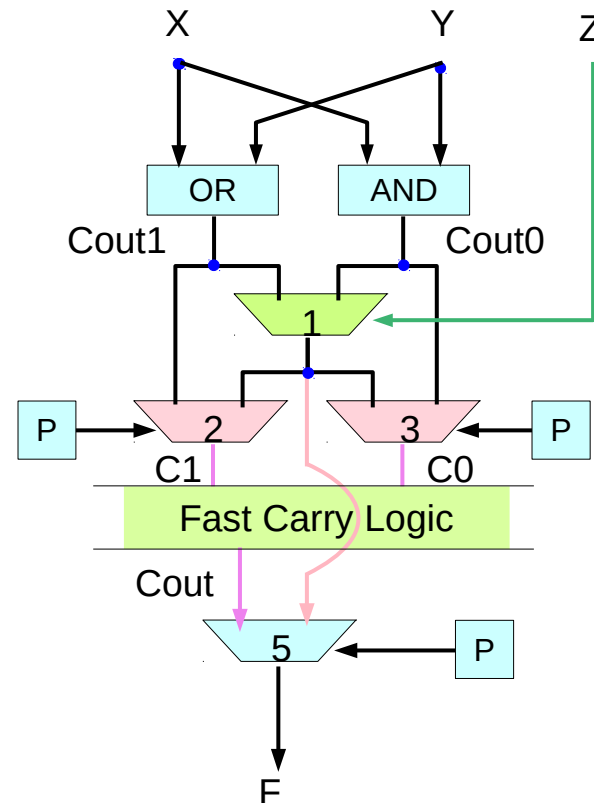

Design C (2)

All the developed fast carry logic units in Design C that can compute the following value, can provide the functionality necessary to support the needs of FPGA carry chain computations

$$Cout_i = (Cout_{i-1} \cdot C1_i) + (\overline{Cout_{i-1}} \cdot C0_i)$$

where i is the position of the cell within the carry chain,

thus, the **fast carry logic unit** can contain any logic structure implementing this equation (including Brent-Kung, Variable Bit, and Ripple Carry).

Note that because of the needs and requirements of carry chains for FPGAs, new circuits are developed, by utilizing the standard adder structures, but which are more appropriate for FPGAs

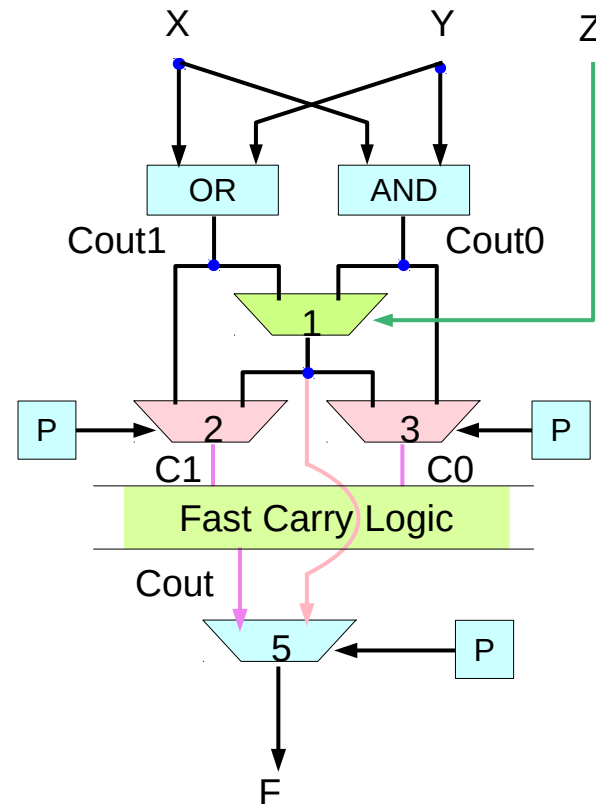

Design C (3)

the main difference is to support all states

- Generate
- Propagate
- Kill
- Inverse Propagate

These 4 states are encoded on signals **C1** and **C0**

Also, while standard adders are concerned only with the maximum delay through an entire **n-bit adder** structure, the delay concerns for FPGAs are more complicated

Specifically, when an **n-bit carry chain** is built into the architecture of an FPGA it does not represent an actual computation, but only the potential for a computation.

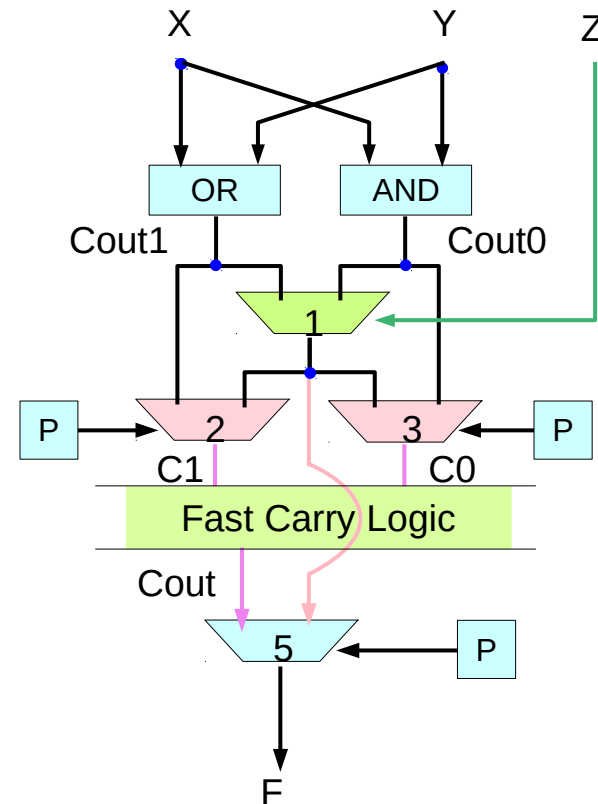

Design C (4)

X	Y	Cin	Cout0	Cin
0	0	0	0	$\overline{X} \overline{Y}$
0	1	1	0	$\overline{X} Y$
1	0	1	0	$X \overline{Y}$
1	1	1	1	$X Y$

Cout1	Cout0	Cout	Name
0	0	0	Kill
0	1	\overline{Cin}	Inverse Propagate
1	0	Cin	Propagate
1	1	1	Generate

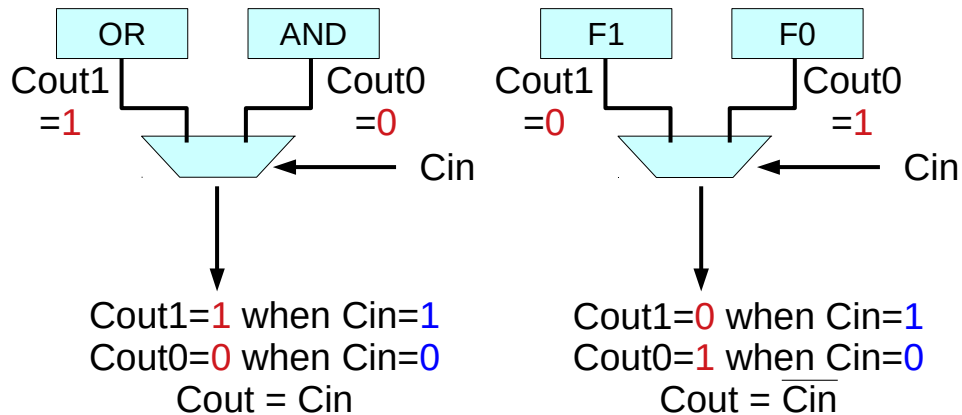

C1	C0	Name
0	0	0 Kill
0	1	\overline{Cin} Inverse Propagate
1	0	Cin Propagate
1	1	1 Generate

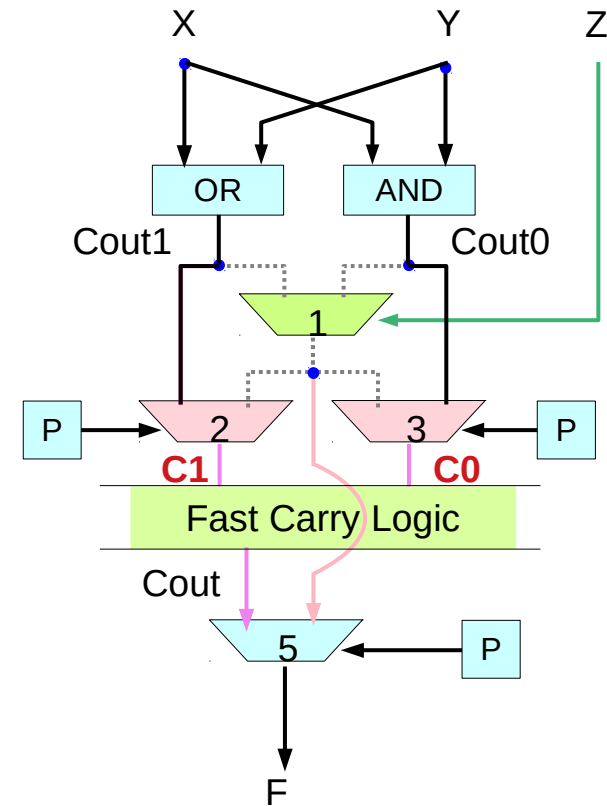

High Performance Carry Chains for FPGAs, S. Hauck, M. M. Hosler, T. W. Fry

Design C (5)

X	Y	C1	C0	
0	0	0	0	$\bar{X}\bar{Y}$
0	1	1	0	$\bar{X}Y$
1	0	1	0	$X\bar{Y}$
1	1	1	1	XY

$$C1_i = X_i + Y_i$$

$$C0_i = X_i \cdot Y_i$$

C1	C0		Name
0	0	0	Kill
0	1	\bar{Cin}	Inverse Propagate
1	0	Cin	Propagate
1	1	1	Generate

$$Cout_i = (Cout_{i-1} \cdot C1_i) + (\overline{Cout_{i-1}} \cdot C0_i)$$

$$(Cout_{i-1} \cdot C1_i) = Cout_{i-1} \cdot (\bar{X}Y + X\bar{Y} + XY)$$

$$(\overline{Cout_{i-1}} \cdot C0_i) = \overline{Cout_{i-1}} \cdot XY$$

X	Y	Cout _i	Cout _{i+1}
0	0	0	0
0	1	0	0
1	0	0	0
1	1	0	1
0	0	1	0
0	1	1	1
1	0	1	1
1	1	1	1

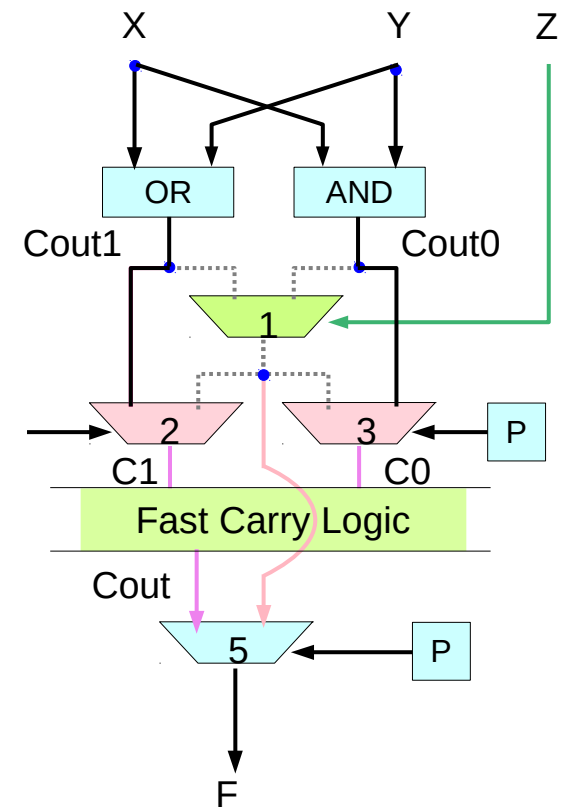

High Performance Carry Chains for FPGAs, S. Hauck, M. M. Hosler, T. W. Fry

Design C (6) - Complements of C0 and C1

$$C1 = \bar{X}Y + X\bar{Y} + XY$$

X	Y	C1
0	0	0
0	1	1
1	0	1
1	1	1

$$C0 = XY$$

X	Y	C0
0	0	0
0	1	0
1	0	0
1	1	1

$$C1 = \bar{X}Y + X\bar{Y} + XY$$

$$C0 = XY$$

$$\bar{C1} = \overline{(\bar{X}Y) + (X\bar{Y}) + (XY)} = \bar{X}\bar{Y}$$

$$\bar{C0} = \bar{X} + \bar{Y} = \bar{X}Y + X\bar{Y} + \bar{X}\bar{Y}$$

$$\bar{C1} = \bar{X}\bar{Y}$$

X	Y	$\bar{C1}$
0	0	0
0	1	1
1	0	1
1	1	1

$$\bar{C0} = \bar{X}Y + X\bar{Y} + \bar{X}\bar{Y}$$

X	Y	$\bar{C0}$
0	0	0
0	1	1
1	0	1
1	1	1

$$Cout_3 = (Cout_1 \cdot (C1_3 \cdot C1_2 + C0_3 \cdot \bar{C1}_2)) + (\bar{Cout}_1 \cdot (C1_3 \cdot C0_2 + C0_3 \cdot \bar{C0}_2))$$

$$= (Cout_1 \cdot (C1_3 \cdot (\bar{X}_2Y_2 + X_2\bar{Y}_2 + X_2Y_2) + C0_3 \cdot \bar{X}_2\bar{Y}_2)) + (\bar{Cout}_1 \cdot (C1_3 \cdot X_2Y_2 + C0_3 \cdot (\bar{X}_2Y_2 + X_2\bar{Y}_2 + \bar{X}_2\bar{Y}_2)))$$

Design C (7) - Cout₃ in terms of Cout₁

X ₃ Y ₃	X ₂ Y ₂	Cout ₂	Cout ₃	Cout ₃
0 0	0 0	0	0	0
0 0	0 1	Cout ₁	0	0
0 0	1 0	Cout ₁	0	0
0 0	1 1	1	0	0
0 1	0 0	0	Cout ₃	0
0 1	0 1	Cout ₁	Cout ₃	Cout ₁
0 1	1 0	Cout ₁	Cout ₃	Cout ₁
0 1	1 1	1	Cout ₃	1
1 0	0 0	0	Cout ₃	0
1 0	0 1	Cout ₁	Cout ₃	Cout ₁
1 0	1 0	Cout ₁	Cout ₃	Cout ₁
1 0	1 1	1	Cout ₃	1
1 1	0 0	0	1	1
1 1	0 1	Cout ₁	1	1
1 1	1 0	Cout ₁	1	1
1 1	1 1	1	1	1

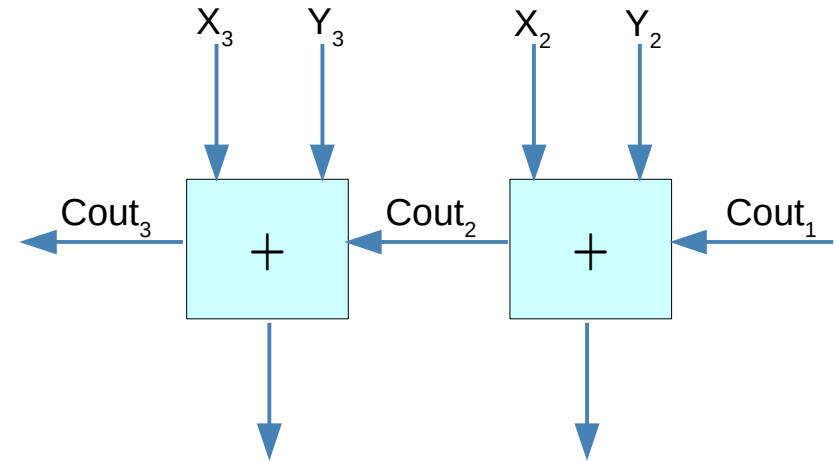

$$Cout_3 = (Cout_1 \cdot (C1_3 \cdot C1_2 + C0_3 \cdot \overline{C1_2})) + (\overline{Cout_1} \cdot (C1_3 \cdot C0_2 + C0_3 \cdot \overline{C0_2}))$$

High Performance Carry Chains for FPGAs, S. Hauck, M. M. Hosler, T. W. Fry

Design C (8) - Cout₃ in terms of Cout₁

X ₃ Y ₃	X ₂ Y ₂	C ₁₃	C ₀₃	C ₁₂	C ₀₂	Cout ₁		$\overline{\text{Cout}}_1$		Cout ³
						C ₁₃ C ₁₂	C ₀₃ $\overline{\text{C}}_1$	C ₁₃ C ₀₂	C ₀₃ $\overline{\text{C}}_0$	
0 0	0 0	0	0	0	0	0	0	0	0	0
0 0	0 1	0	0	1	0	0	0	0	0	0
0 0	1 0	0	0	1	0	0	0	0	0	0
0 0	1 1	0	0	1	1	0	0	0	0	0
0 1	0 0	1	0	0	0	0	0	0	0	0
0 1	0 1	1	0	1	0	1	0	0	0	Cout ₁
0 1	1 0	1	0	1	0	1	0	0	0	Cout ₁
0 1	1 1	1	0	1	1	1	0	1	0	1
1 0	0 0	1	0	0	0	0	0	0	0	0
1 0	0 1	1	0	1	0	1	0	0	0	Cout ₁
1 0	1 0	1	0	1	0	1	0	0	0	Cout ₁
1 0	1 1	1	0	1	1	1	0	1	0	1
1 1	0 0	1	1	0	0	0	1	0	1	1
1 1	0 1	1	1	1	0	1	0	0	1	1
1 1	1 0	1	1	1	0	1	0	0	1	1
1 1	1 1	1	1	1	1	1	0	1	0	1

$$\text{Cout}_3 = (\text{Cout}_1 \cdot (C_{13} \cdot C_{12} + C_{03} \cdot \overline{C_{12}})) + (\overline{\text{Cout}}_1 \cdot (C_{13} \cdot C_{02} + C_{03} \cdot \overline{C_{02}}))$$

High Performance Carry Chains for FPGAs, S. Hauck, M. M. Hosler, T. W. Fry

Design C (9) - When Cout1 = 1

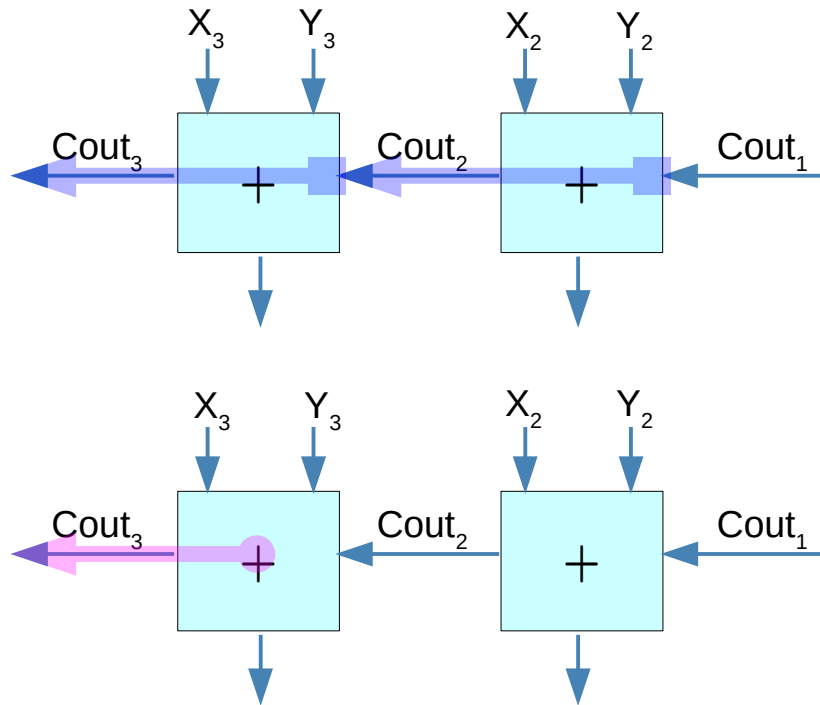

$$C1_3 \cdot C1_2 \cdot Cout_1$$

prop

prop

$$\overline{X_3}Y_3$$

$$\overline{X_2}Y_2$$

$$X_3\overline{Y_3}$$

$$X_2\overline{Y_2}$$

$$X_3Y_3$$

$$X_2Y_2$$

$$C0_3 \cdot \overline{C1_2} \cdot Cout_1$$

gen

$\overline{\text{prop}}$

$$X_3Y_3$$

$$\overline{X_2}Y_2$$

$$Cout_3 = (Cout_1 \cdot (C1_3 \cdot C1_2 + C0_3 \cdot \overline{C1_2})) + (\overline{Cout_1} \cdot (C1_3 \cdot C0_2 + C0_3 \cdot \overline{C0_2}))$$

Design C (10) - When Cout1 = 0

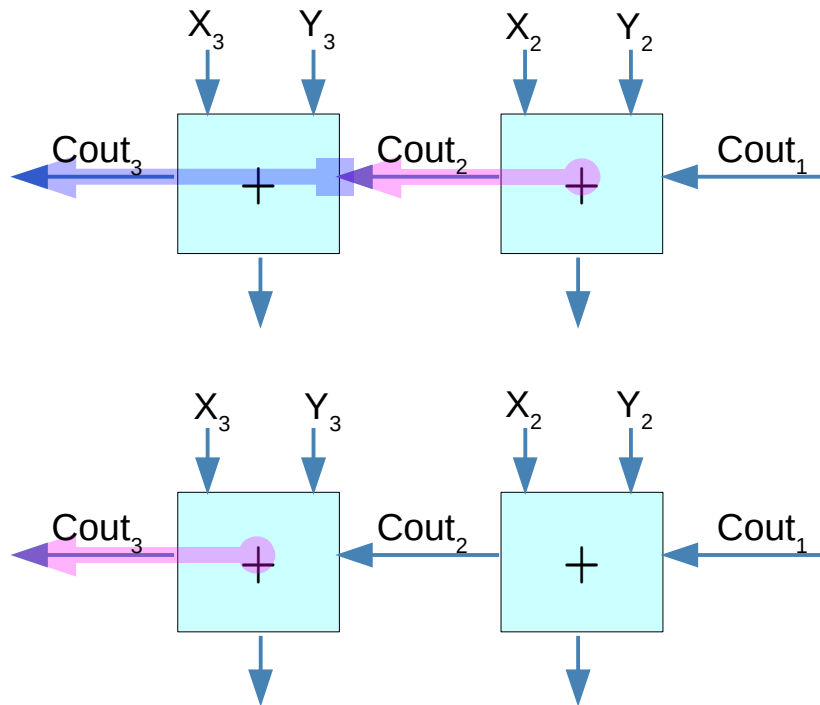

$$C1_3 \cdot C0_2 \cdot \overline{Cout_1}$$

prop

gen

$$\overline{X_3}Y_3$$

$$X_2Y_2$$

$$X_3\overline{Y_3}$$

$$X_3Y_3$$

$$C0_3 \cdot \overline{C0_2} \cdot \overline{Cout_1}$$

gen

gen

$$X_3Y_3$$

$$\overline{X_2}Y_2$$

$$X_2\overline{Y_2}$$

$$X_2Y_2$$

$$Cout_3 = (Cout_1 \cdot (C1_3 \cdot C1_2 + C0_3 \cdot \overline{C1_2})) + (\overline{Cout_1} \cdot (C1_3 \cdot C0_2 + C0_3 \cdot \overline{C0_2}))$$

$$(C1_3 C1_2 + C0_3 \overline{C1_2})Cout_1 + (C1_3 C0_2 + C0_3 \overline{C0_2})\overline{Cout_1}$$

High Performance Carry Chains for FPGAs, S. Hauck, M. M. Hosler, T. W. Fry

Design C (11) - When Cout1 = 1

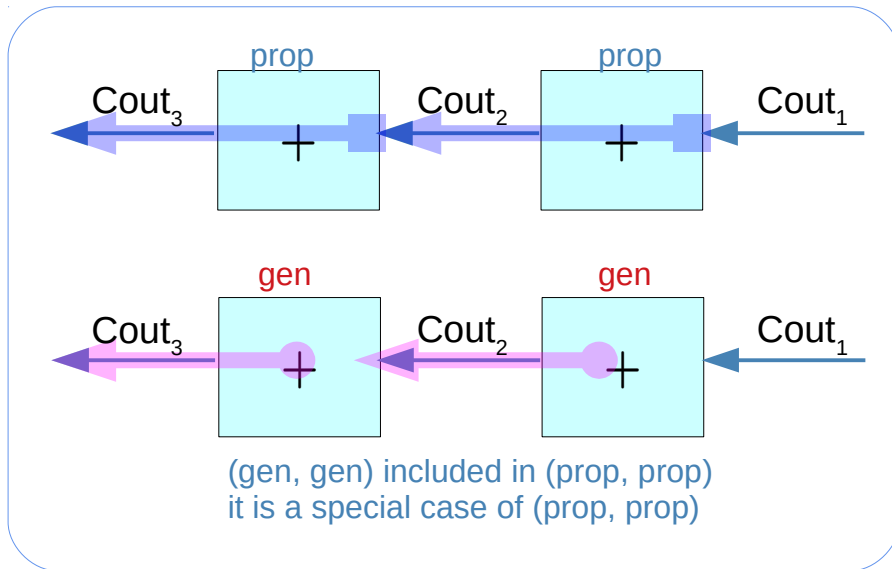

$$C 1_3 \cdot C 1_2 \cdot Cout_1$$

prop	prop
$\bar{X}_3 Y_3$	$\bar{X}_2 Y_2$
$X_3 \bar{Y}_3$	$X_2 \bar{Y}_2$
$X_3 Y_3$	$X_2 Y_2$

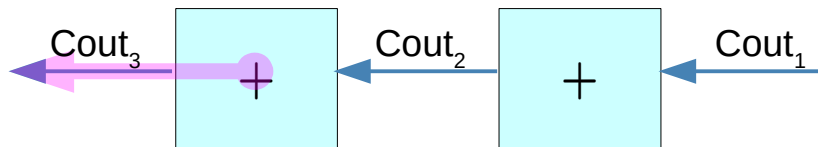

$$C 0_3 \cdot \overline{C 1_2} \cdot Cout_1$$

gen	$\overline{\text{prop}}$
$X_3 Y_3$	$\overline{X_2 Y_2}$

$$Cout_3 = (Cout_1 \cdot (C 1_3 \cdot C 1_2 + C 0_3 \cdot \overline{C 1_2})) + (\overline{Cout_1} \cdot (C 1_3 \cdot C 0_2 + C 0_3 \cdot \overline{C 0_2}))$$

High Performance Carry Chains for FPGAs, S. Hauck, M. M. Hosler, T. W. Fry

Design C (12) - When Cout1 = 0

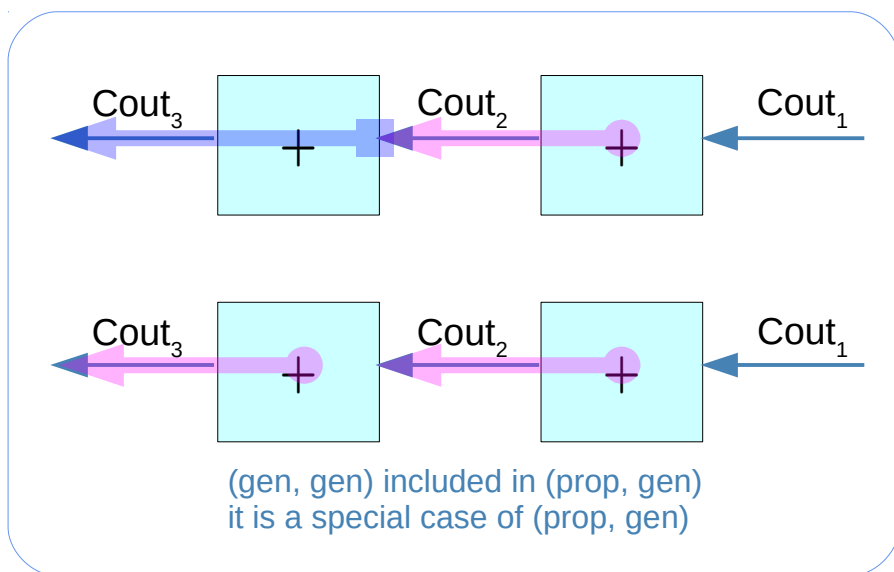

$$C1_3 \cdot C0_2 \cdot \overline{Cout_1}$$

prop

gen

$$\overline{X_3 Y_3}$$

$$X_2 Y_2$$

$$X_3 \overline{Y_3}$$

$$X_3 Y_3$$

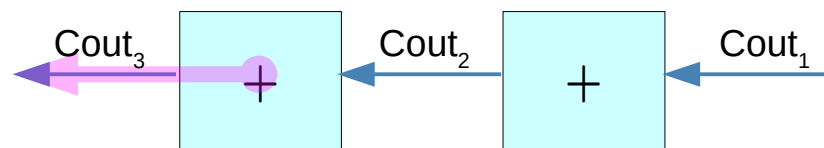

$$C0_3 \cdot \overline{C0_2} \cdot \overline{Cout_1}$$

gen

gen

$$X_3 Y_3$$

$$\overline{X_2 Y_2}$$

$$X_2 \overline{Y_2}$$

$$X_2 Y_2$$

$$Cout_3 = (Cout_1 \cdot (C1_3 \cdot C1_2 + C0_3 \cdot \overline{C1_2})) + (\overline{Cout_1} \cdot (C1_3 \cdot C0_2 + C0_3 \cdot \overline{C0_2}))$$

$$(C1_3 C1_2 + C0_3 \overline{C1_2}) Cout_1 + (C1_3 C0_2 + C0_3 \overline{C0_2}) \overline{Cout_1}$$

High Performance Carry Chains for FPGAs, S. Hauck, M. M. Hosler, T. W. Fry

FPGA Carry Chain Cell

$$C1 = \bar{X}Y + X\bar{Y} + XY \quad C0 = XY$$

$$\bar{C1} = \bar{X}\bar{Y}$$

$$\bar{C0} = \bar{X}Y + X\bar{Y} + \bar{X}\bar{Y}$$

C1 and C0 are not mutually exclusive

C1 includes C0

$$C1 \cdot C0 = C0$$

$$C1 + C0 = C1$$

$$\bar{C1} \cdot \bar{C0} = \bar{C1}$$

$$\bar{C1} + \bar{C0} = \bar{C0}$$

High Performance Carry Chains for FPGAs, S. Hauck, M. M. Hosler, T. W. Fry

Design C - Carry Select (1)

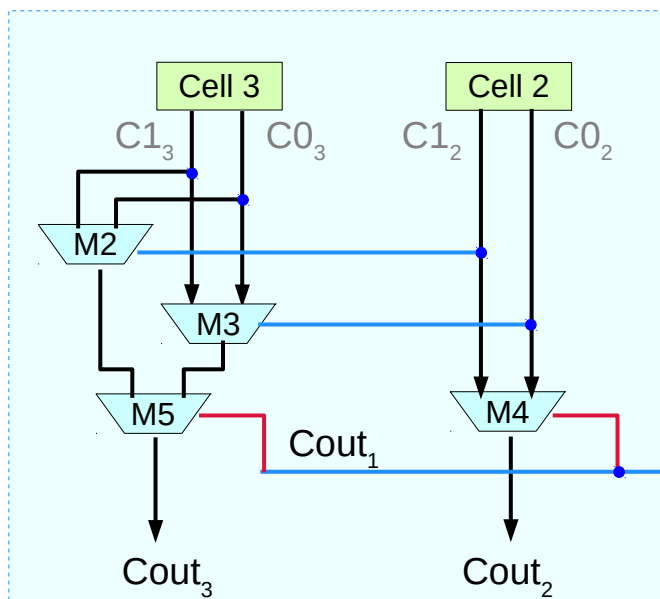

$$C1 = \bar{X}Y + X\bar{Y} + XY \quad C0 = XY$$

$$\bar{C1} = \bar{X}\bar{Y} \quad \bar{C0} = \bar{X}Y + X\bar{Y} + \bar{X}\bar{Y}$$

$$Cout_3 = (Cout_2 \cdot C1_3) + (\bar{Cout}_2 \cdot C0_3)$$

$$Cout_2 = (Cout_1 \cdot C1_2) + (\bar{Cout}_1 \cdot C0_2)$$

$$Cout_1 = (Cout_0 \cdot C1_1) + (\bar{Cout}_0 \cdot C0_1)$$

$$Cout_3 = (Cout_1 \cdot (C1_3 \cdot C1_2 + C0_3 \cdot \bar{C1}_2)) + (\bar{Cout}_1 \cdot (C1_3 \cdot C0_2 + C0_3 \cdot \bar{C0}_2))$$

$$= (Cout_1 \cdot (C1_3 \cdot (\bar{X}_2 Y_2 + X_2 \bar{Y}_2 + X_2 Y_2) + C0_3 \cdot \bar{X}_2 \bar{Y}_2)) + (\bar{Cout}_1 \cdot (C1_3 \cdot X_2 Y_2 + C0_3 \cdot (\bar{X}_2 Y_2 + X_2 \bar{Y}_2 + \bar{X}_2 \bar{Y}_2)))$$

High Performance Carry Chains for FPGAs, S. Hauck, M. M. Hosler, T. W. Fry

FPGA Carry Chain Cell

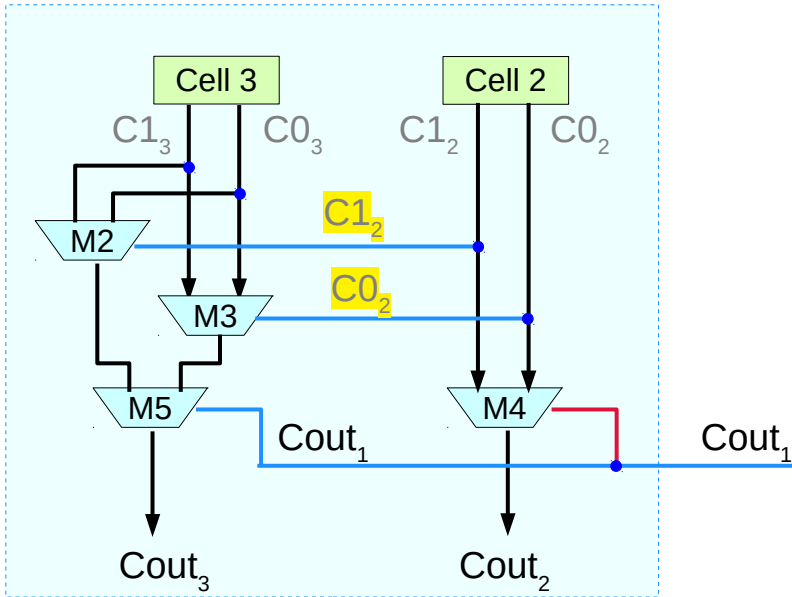

$$Cout_2 = (Cout_1 \cdot C1_2) + (\overline{Cout_1} \cdot C0_2)$$

$$Cout_3 = (Cout_2 \cdot C1_3) + (\overline{Cout_2} \cdot C0_3)$$

$$= (((Cout_1 \cdot C1_2) + (\overline{Cout_1} \cdot C0_2)) \cdot C1_3)$$

$$+ (((Cout_1 \cdot C1_2) + (\overline{Cout_1} \cdot C0_2)) \cdot C0_3)$$

$$(((Cout_1 \cdot C1_2) + (\overline{Cout_1} \cdot C0_2)) \cdot C1_3)$$

$$= (C1_3 C1_2 Cout_1 + C1_3 C0_2 \overline{Cout_1})$$

$$(((\overline{Cout_1} \cdot C1_2) \cdot (\overline{Cout_1} \cdot C0_2)) \cdot C0_3)$$

$$= (((\overline{Cout_1} + \overline{C1_2}) \cdot (\overline{Cout_1} + \overline{C0_2})) \cdot C0_3)$$

$$= (\overline{Cout_1} \overline{Cout_1} + \overline{C1_2} \overline{Cout_1} + \overline{Cout_1} \overline{C0_2} + \overline{C1_2} \overline{C0_2}) \cdot C0_3$$

$$= (\overline{C1_2} \overline{Cout_1} + \overline{C0_2} \overline{Cout_1}) \cdot C0_3$$

$$= (C0_3 \overline{C1_2} \overline{Cout_1} + C0_3 \overline{C0_2} \overline{Cout_1})$$

$$\overline{C1_2} \overline{C0_2} = (\overline{X_2} \overline{Y_2}) \cdot (\overline{X_2} Y_2 + X_2 \overline{Y_2} + \overline{X_2} \overline{Y_2}) = \overline{C1_2}$$

$$\overline{C1_2} \overline{Cout_1} + \overline{C1_2} = \overline{C1_2} (\overline{Cout_1} + 1)$$

$$(C1_3 C1_2 + C0_3 \overline{C1_2}) Cout_1 + (C1_3 C0_2 + C0_3 \overline{C0_2}) \overline{Cout_1}$$

$$C1 = \overline{X} Y + X \overline{Y} + X Y \quad C0 = X Y$$

$$\overline{C1} = \overline{X} \overline{Y} \quad \overline{C0} = \overline{X} Y + X \overline{Y} + \overline{X} \overline{Y}$$

High Performance Carry Chains for FPGAs, S. Hauck, M. M. Hosler, T. W. Fry

FPGA Carry Chain Cell

$$\begin{aligned}
 &= (\overline{Cout_1}Cout_1 + \overline{C1_2}Cout_1 + \overline{Cout_1}\overline{C0_2} + \overline{C1_2}\overline{C0_2}) \cdot C0_3 \\
 &= (\overline{C1_2}Cout_1 + \overline{Cout_1}\overline{C0_2} + \overline{C1_2}\overline{C0_2}) \cdot C0_3 \\
 &= (\overline{C1_2}\overline{C0_2}Cout_1 + \overline{Cout_1}\overline{C0_2} + \overline{C1_2}\overline{C0_2}) \cdot C0_3
 \end{aligned}$$

$$C1 \cdot C0 = C0$$

$$C1 + C0 = C1$$

$$\overline{C1} \cdot \overline{C0} = \overline{C1}$$

$$\overline{C1} + \overline{C0} = \overline{C0}$$

$$Cout_2 = (Cout_1 \cdot C1_2) + (\overline{Cout_1} \cdot C0_2)$$

$$Cout_3 = (Cout_2 \cdot C1_3) + (\overline{Cout_2} \cdot C0_3)$$

$$= (((Cout_1 \cdot C1_2) + (\overline{Cout_1} \cdot C0_2)) \cdot C1_3)$$

$$+ (((\overline{Cout_1} \cdot C1_2) + (\overline{Cout_1} \cdot C0_2)) \cdot C0_3)$$

$$(((Cout_1 \cdot C1_2) + (\overline{Cout_1} \cdot C0_2)) \cdot C1_3)$$

$$= (C1_3 C1_2 Cout_1 + C1_3 C0_2 \overline{Cout_1})$$

$$(((\overline{Cout_1} \cdot C1_2) \cdot (\overline{Cout_1} \cdot C0_2)) \cdot C0_3)$$

$$= (((\overline{Cout_1} + \overline{C1_2}) \cdot (\overline{Cout_1} + \overline{C0_2})) \cdot C0_3)$$

$$= (\overline{Cout_1}Cout_1 + \overline{C1_2}Cout_1 + \overline{Cout_1}\overline{C0_2} + \overline{C1_2}\overline{C0_2}) \cdot C0_3$$

$$= (\overline{C1_2}Cout_1 + \overline{C0_2}\overline{Cout_1}) \cdot C0_3$$

$$= (C0_3 \overline{C1_2}Cout_1 + C0_3 \overline{C0_2}\overline{Cout_1})$$

$$\overline{C1_2}\overline{C0_2} = (\overline{X_2}\overline{Y_2}) \cdot (\overline{X_2}Y_2 + X_2\overline{Y_2} + \overline{X_2}\overline{Y_2}) = \overline{C1_2}$$

$$\overline{C1_2}Cout_1 + \overline{C1_2} = \overline{C1_2}(Cout_1 + 1)$$

High Performance Carry Chains for FPGAs, S. Hauck, M. M. Hosler, T. W. Fry

FPGA Carry Chain Cell

$$C1 = \bar{X}Y + X\bar{Y} + XY \quad C0 = XY$$

$$\bar{C1} = \bar{X}\bar{Y} \quad \bar{C0} = \bar{X}Y + X\bar{Y} + \bar{X}\bar{Y}$$

C1 and C0 are not mutually exclusive

C1 includes C0

$$Cout_2 = (Cout_1 \cdot C1_2) + (\bar{Cout}_1 \cdot C0_2)$$

$$Cout_3 = (Cout_2 \cdot C1_3) + (\bar{Cout}_2 \cdot C0_3)$$

$$= (((Cout_1 \cdot C1_2) + (\bar{Cout}_1 \cdot C0_2)) \cdot C1_3)$$

$$+ (((Cout_1 \cdot C1_2) + (\bar{Cout}_1 \cdot C0_2)) \cdot C0_3)$$

$$\overline{((Cout_1 \cdot C1_2) + (\bar{Cout}_1 \cdot C0_2))}$$

$$\overline{((Cout_1 \cdot (C1_2 + C0_2)) + (\bar{Cout}_1 \cdot C0_2))}$$

$$\overline{(Cout_1 \cdot C1_2 + (Cout_1 + \bar{Cout}_1) \cdot C0_2)}$$

$$\overline{(Cout_1 \cdot C1_2 + C0_2)}$$

$$((\bar{Cout}_1 + \bar{C1}_2) \cdot \bar{C0}_2)$$

$$((\bar{Cout}_1 \cdot \bar{C0}_2 + \bar{C1}_2))$$

$$= (\bar{Cout}_1 \bar{Cout}_1 + \bar{C1}_2 \bar{Cout}_1 + \bar{Cout}_1 \bar{C0}_2 + \bar{C1}_2 \bar{C0}_2)$$

$$= (\bar{C1}_2 \bar{Cout}_1 + \bar{Cout}_1 \bar{C0}_2 + \bar{C1}_2)$$

$$= (\bar{C1}_2 + \bar{Cout}_1 \bar{C0}_2)$$

High Performance Carry Chains for FPGAs, S. Hauck, M. M. Hosler, T. W. Fry

Design C - Carry Select (1)

$$C1 = \bar{X}Y + X\bar{Y} + XY$$

$$C0 = XY$$

$$\bar{C1} = \bar{X}\bar{Y}$$

$$\bar{C0} = \bar{X}Y + X\bar{Y} + \bar{X}\bar{Y}$$

C1	C0	Name
0	0	0 Kill
0	1	\bar{Cin} Inverse Propagate
1	0	Cin Propagate
1	1	1 Generate

$$Cout_1 = (Cout_0 \cdot C1_1) + (\bar{Cout}_0 \cdot C0_1)$$

$$Cout_2 = (Cout_1 \cdot C1_2) + (\bar{Cout}_1 \cdot C0_2)$$

$$Cout_3 = (Cout_2 \cdot C1_3) + (\bar{Cout}_2 \cdot C0_3)$$

$$Cout_3 = (Cout_1 \cdot (C1_3 \cdot C1_2 + C0_3 \cdot \bar{C1}_2)) + (\bar{Cout}_1 \cdot (C1_3 \cdot C0_2 + C0_3 \cdot \bar{C0}_2))$$

$$= Cout_1 \cdot [(\bar{X}Y + X\bar{Y} + XY)_3 \cdot (\bar{X}Y + X\bar{Y} + XY)_2 + (XY)_3 \cdot (XY)_2] + \bar{Cout}_1 \cdot [(\bar{X}Y + X\bar{Y} + XY)_3 \cdot (XY)_2 + (XY)_3 \cdot (\bar{X}Y + X\bar{Y} + \bar{X}\bar{Y})_2]$$

$$= (Cout_1 \cdot (C1_3 \cdot (\bar{X}_2Y_2 + X_2\bar{Y}_2 + X_2Y_2) + C0_3 \cdot \bar{X}_2\bar{Y}_2)) + (\bar{Cout}_1 \cdot (C1_3 \cdot X_2Y_2 + C0_3 \cdot (\bar{X}_2Y_2 + X_2\bar{Y}_2 + \bar{X}_2\bar{Y}_2)))$$

High Performance Carry Chains for FPGAs, S. Hauck, M. M. Hosler, T. W. Fry

Design C (3)

A **carry chain resource** may span the entire height of a **column** in the FPGA, but a **mapping** to the logic may use only a small portion of this chain, with the **carry logic** in the mapping starting and ending at arbitrary points in the **column**

Must consider

- the **carry delay** from the first to the last position in a **carry chain**,
- the delay for a **carry computation** beginning at any point within this **column**.

For example, even though the FPGA architecture may provide support for **carry chains** of up to **32 bits**, it must also efficiently support **8 bit carry computations** placed at any point within this **carry chain** resource

Design C (4)

Carry Select

the problem with a **ripple carry** structure is that the **computation** of the **Cout** for bit position **i** cannot begin until after the **computation** has been completed in bit positions **0 .. i-1**

A **carry select** structure overcomes this limitation

the main observation is that for any bit position, the only information it received from the previous bit positions is its **Cin** signal, which can be either **true** or **false**.

Design C (5)

In a **carry select adder** the **carry chain** is broken at a specific **column**, and two separate additions occur

one for the **true Cin** signal
the other for the **false Cin** signal

These computations can take place before the completion of the **previous columns**, since they do not depend on the actual value of the **Cin** signal

This **Cin** signal is instead used to determine which adder's outputs should be used

if the **Cin** signal is **true**, the output of the following stages comes from the adder that assumed that the **Cin** would be **true**

likewise, a **false Cin** chooses the other adder's output

Design C (6)

This splitting of the **carry chain** can be done multiple times, breaking the computation into several pairs of **short adders** with **output muxes** choosing which adder's output to **select**

the length of the adders and the breakpoint are carefully chosen such that the **small adders** finish computation just as their **Cin** signals become available

Short adders handle the low-order bits, and the adder length is increased further along the carry chain, since later computations have more time until their **Cin** signal is available

High Performance Carry Chains for FPGAs, S. Hauck, M. M. Hosler, T. W. Fry

FPGA Carry Chain Cell

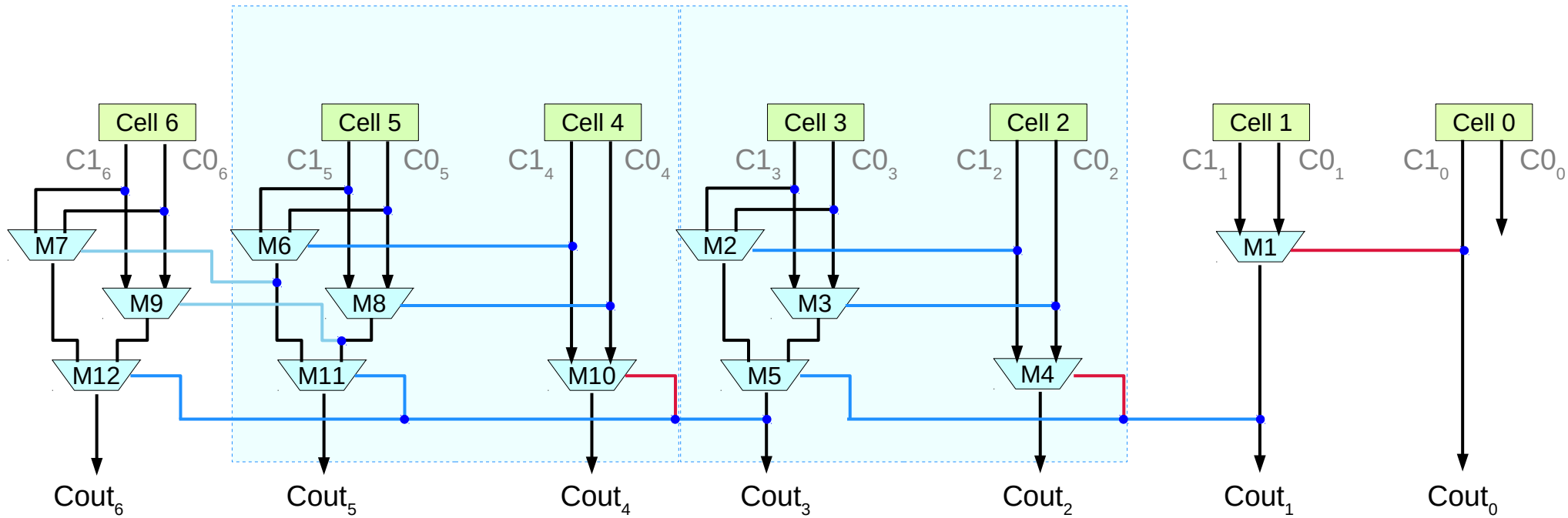

$$Cout_i = (Cout_{i-1} \cdot C1_i) + (\overline{Cout_{i-1}} \cdot C0_i)$$

$$Cout_1 = (Cout_0 \cdot C1_1) + (\overline{Cout_0} \cdot C0_1)$$

$$Cout_{i+1} = (Cout_i \cdot C1_{i+1}) + (\overline{Cout_i} \cdot C0_{i+1})$$

$$Cout_1 = (C1_0 \cdot C1_1) + (\overline{C1_0} \cdot C0_1)$$

$$Cout_{i+1} = (((Cout_{i-1} \cdot C1_i) + (\overline{Cout_{i-1}} \cdot C0_i)) \cdot C1_{i+1}) + (\overline{((Cout_{i-1} \cdot C1_i) + (\overline{Cout_{i-1}} \cdot C0_i))} \cdot C0_{i+1})$$

High Performance Carry Chains for FPGAs, S. Hauck, M. M. Hosler, T. W. Fry

Design C - Carry Select (1)

A **Carry Select** carry chain structure for use in FPGAs

the carry computation for the first two cells is performed with the simple **ripple-carry** structure implemented by **mux1**

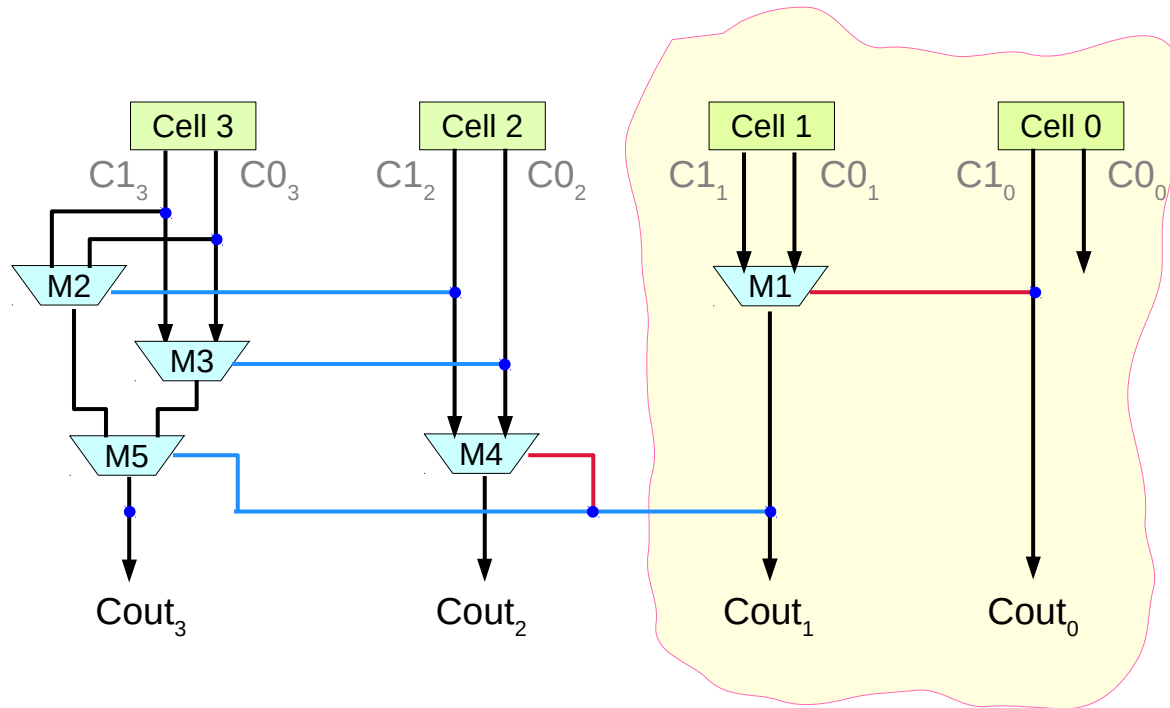

High Performance Carry Chains for FPGAs, S. Hauck, M. M. Hosler, T. W. Fry

Design C - Carry Select (2)

A **Carry Select** carry chain structure for use in FPGAs

For **cell2** and **cell3** we use two ripple carry adders,

with one adder (**mux2**) assuming the **Cin** is **true**,

and the other (**mux3**) assuming the **Cin** is **false**

Then **mux4** and **mux5** pick between these two adders' outputs based on the actual **Cin** coming from **mux1**.

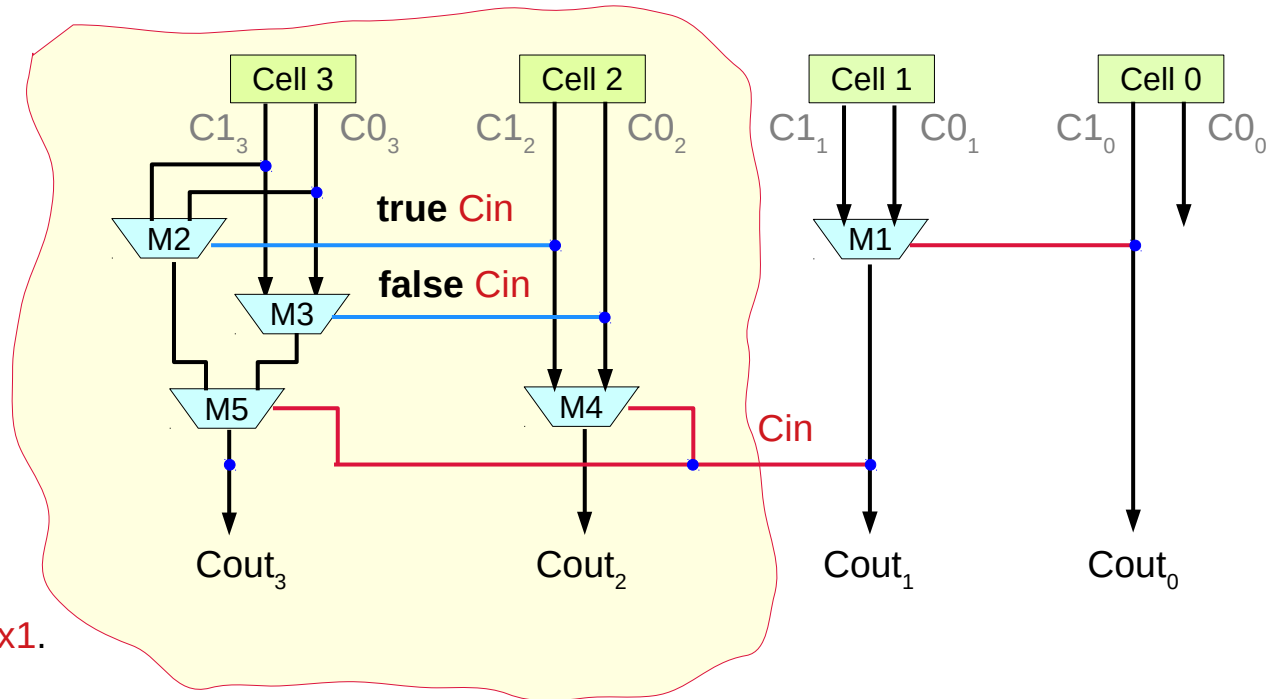

Design C - Carry Select (3)

Similarly, **cell4**, **cell5**, **cell6** have

two ripple carry adders

mux6 & **mux7** for a **Cin** of 1

mux8 & **mux9** for a **Cin** of 0

with output muxes (**mux10**, **mux11**, **mux12**)
deciding between the two
based upon the actual **Cin** (from **mux5**).

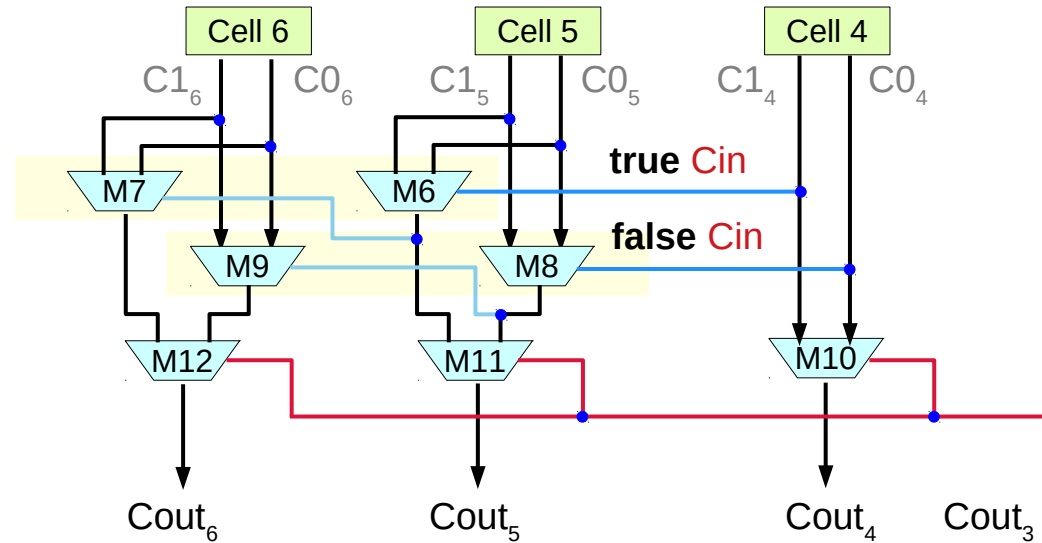

High Performance Carry Chains for FPGAs, S. Hauck, M. M. Hosler, T. W. Fry

Design C - Carry Select (3)

Subsequent stages will continue to grow in length by one,

with **cells7**, **cell8**, **cell9**, **cell10** in one block,

cell11, **cell12**, **cell13**, **cell14**, **cell15** in another,

and so on.

timing values showing the delay of the Carry Select carry chain relative to other carry chain will be presented later

Design C

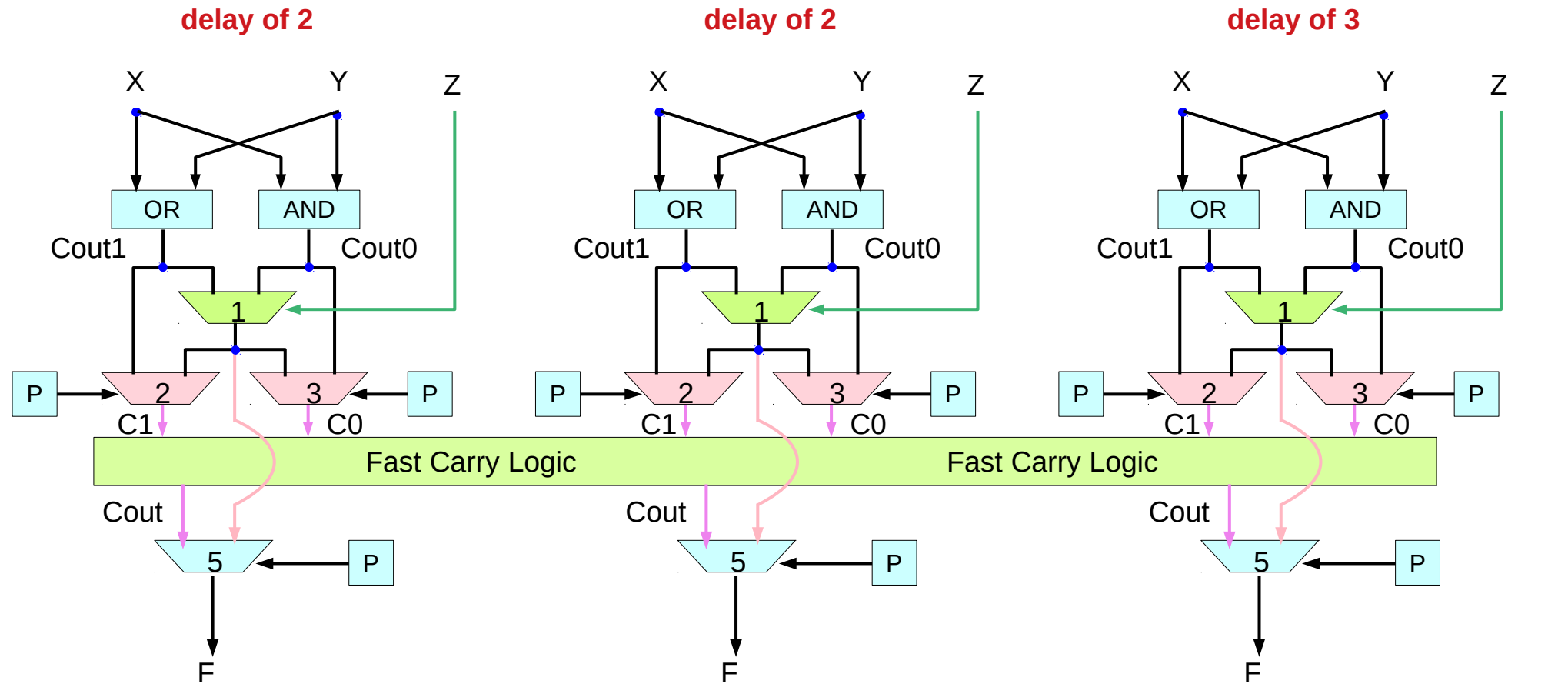

(1 for mux1, 1 for mux2, 1 in mux4)

delay of $2n+2$ for an **n-bit** ripple carry chain

High Performance Carry Chains for FPGAs, S. Hauck, M. M. Hosler, T. W. Fry

FPGA Carry Chain Cell

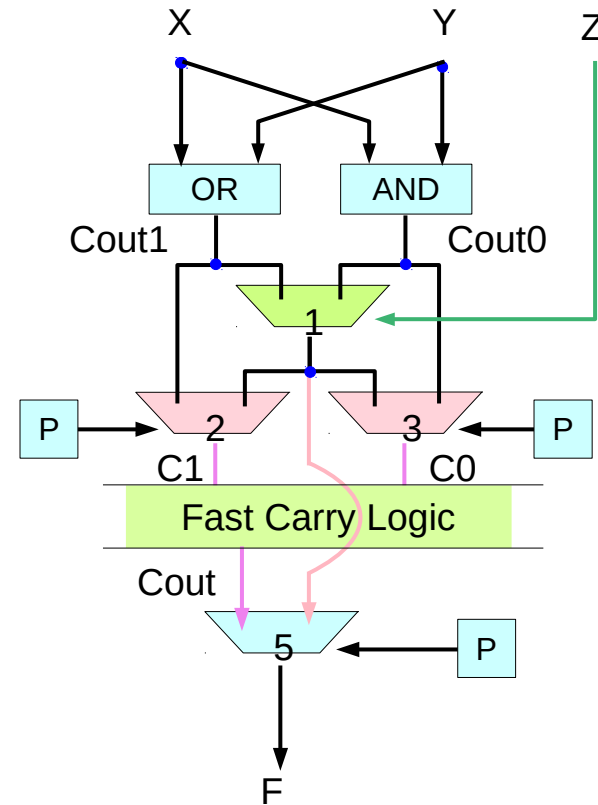
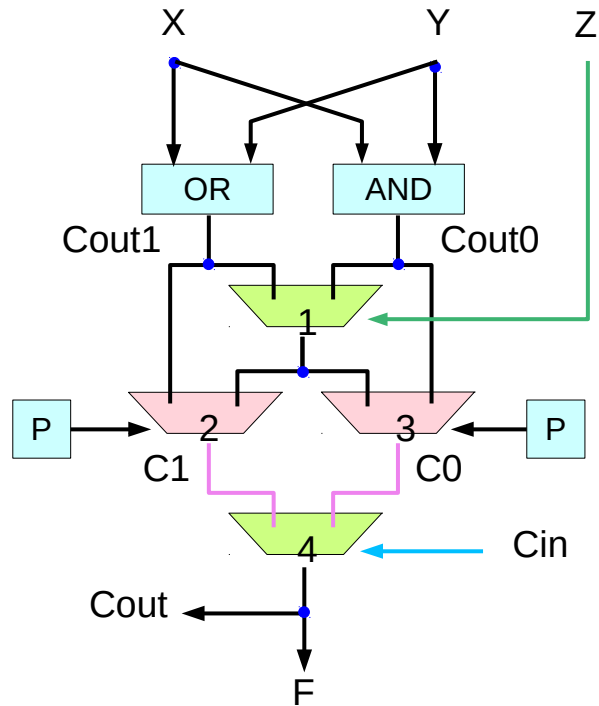

$$Cout_i = (Cout_{i-1} \cdot C1_i) + (\overline{Cout_{i-1}} \cdot C0_i)$$

High Performance Carry Chains for FPGAs, S. Hauck, M. M. Hosler, T. W. Fry

FPGA Carry Chain Cell

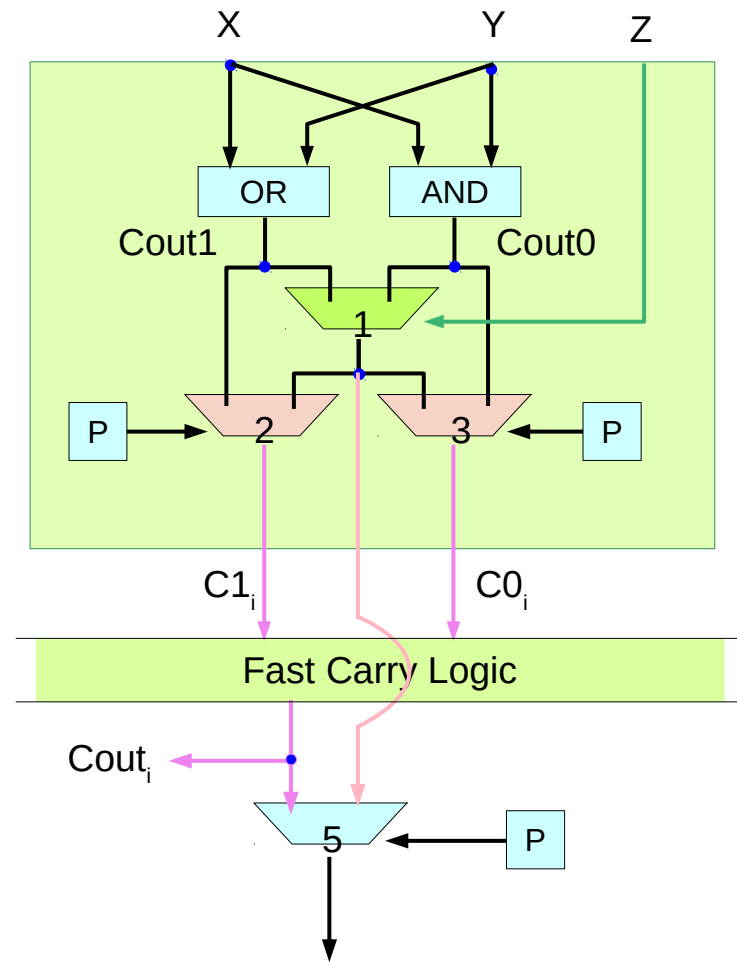

$$Cout_i = (Cout_{i-1} \cdot C1_i) + (\overline{Cout_{i-1}} \cdot C0_i)$$

High Performance Carry Chains for FPGAs, S. Hauck, M. M. Hosler, T. W. Fry

Fast Carry Logc

Carry Select Adder
Carry Lookahead Adder
 Brent-Kung
Variable Block
Ripple Carry Adder

https://en.wikipedia.org/wiki/Carry-lookahead_adder

Variable Block

like the carry select chain, a variable block structure consists of blocks of ripple carry element however, instead of precomputing the Cout value for each possible Cin value, it instead provides a way for the carry signal to skip over intermediate cells where appropriate.

Contiguous blocks of the computation are grouped together to form a unit with a standard ripple carry chain As part of this block, logic is to the value of the block's Cin, allowing the carry chain to bypass this block's normal carry chain on its way to later blocks.

https://en.wikipedia.org/wiki/Carry-lookahead_adder

Variable Block

The Cin still ripples through the block itself, since the intermediate carry values must also be computed. If any of the cells in the carry chain are not in propagate mode, the Cout output is generated normally by the ripple carry chain. While this carry chain does start at the block's Cin signal, and leads to the block's Cout, this long path is a false path. That is since there is some cell in the block that is not in propagate mode, it must be in generate or kill mode, and thus the block's Cout output does not depend on the block's Cin input.

https://en.wikipedia.org/wiki/Carry-lookahead_adder

Variable Block

the variable block carry structure

mux1 performs an initial two stage ripple carry

mux2 ~ mux5 form a 2-bit variable block

mux5 decides whether the Cin signal should be sent directly to Cout, while mux4 decides whether to invert the Cin signal or not

https://en.wikipedia.org/wiki/Carry-lookahead_adder

Variable Block

a major difficulty in developing a version of the Variable Block carry chain for inclusion in an FPGA's architecture is the need to support both the propagate and inverse propagate state the cells.

To do this, we compute two values.

First, we check to see if all the cells are in some form of propagate mode (either normal propagate or inverse propagate) by ANDing together the XOR of each stage's C1 and C0 signal

If so, we know that the Cout function will be equal to either Cin or Cin bar.

https://en.wikipedia.org/wiki/Carry-lookahead_adder

Variable Block

to decide whether to invert the signal or not,
we must determine how many cells are in inverse propagate mode.
if the number is even (including zero), the output is not inverted,
while if the number is odd, the output is inverted.

the inversion check can be done by looking for inverse
signal from each cell.

if this signal is true, the cell is in either generate or
inverse propagate mode, and if it is in generate mode inversion signal
will be ignored anyway (we only consider inverting the Cin signal
if all cells are in some form of propagate mode).

https://en.wikipedia.org/wiki/Carry-lookahead_adder

Variable Block

note that for both of these tests we can use a tree of gates to compute the result.

Also, since we ignore the inversion signal when we are not bypassing the carry chain we can use C_1 as the inverse of C_0 for the inversion signal's computation, which avoids the added inverter in the XOR gate

the organization of the blocks in the variable block carry structure bears some similarity to the carry select structure
the early stages of the structure grow in length, with short blocks for the low order bits, building in length further in the chain in order to equalize the arrival time of the carry from the block with that of the previous block

https://en.wikipedia.org/wiki/Carry-lookahead_adder

Variable Block

however, unlike the carry select structure, the variable block adder must also worry about the delay from the Cin input through the block's ripple chain

Thus, after the carry chain passes the midpoint of the logic, the blocks begin decreasing in length.

This balances the path delays in the system and improves performance

The division of the overall structure into blocks depends on the details of the logic structure and the length fo the entire computation

https://en.wikipedia.org/wiki/Carry-lookahead_adder

Variable Block

We use a block length from low order to high order cells of 2, 2, 4, 5, 7, 5, 4, 2, 1 for a normal 32 bit structure
The first and last block in each adder is a simple ripple carry chain, while all other blocks use the variable block structure.

Delay values of the variable block carry chain relative to other carry chains

https://en.wikipedia.org/wiki/Carry-lookahead_adder

Carry Lookahead and Brent-Kung

there are two inputs to the fast carry logic $C1$, $C0$
the value of $C1$, is programmed by the LUT's so that
it contains the value that $Cout$ should have if Cin is false.

We can combine the information from two stages together
to determine what the $Cout$ of one stage will be given
the Cin of the previous stage.

https://en.wikipedia.org/wiki/Carry-lookahead_adder