

Latch Time Borrow (4C)

-
-

Copyright (c) 2010-2013 Young W. Lim.

Permission is granted to copy, distribute and/or modify this document under the terms of the GNU Free Documentation License, Version 1.2 or any later version published by the Free Software Foundation; with no Invariant Sections, no Front-Cover Texts, and no Back-Cover Texts. A copy of the license is included in the section entitled "GNU Free Documentation License".

Please send corrections (or suggestions) to youngwlim@hotmail.com.

This document was produced by using OpenOffice and Octave.

The Combinational Circuits

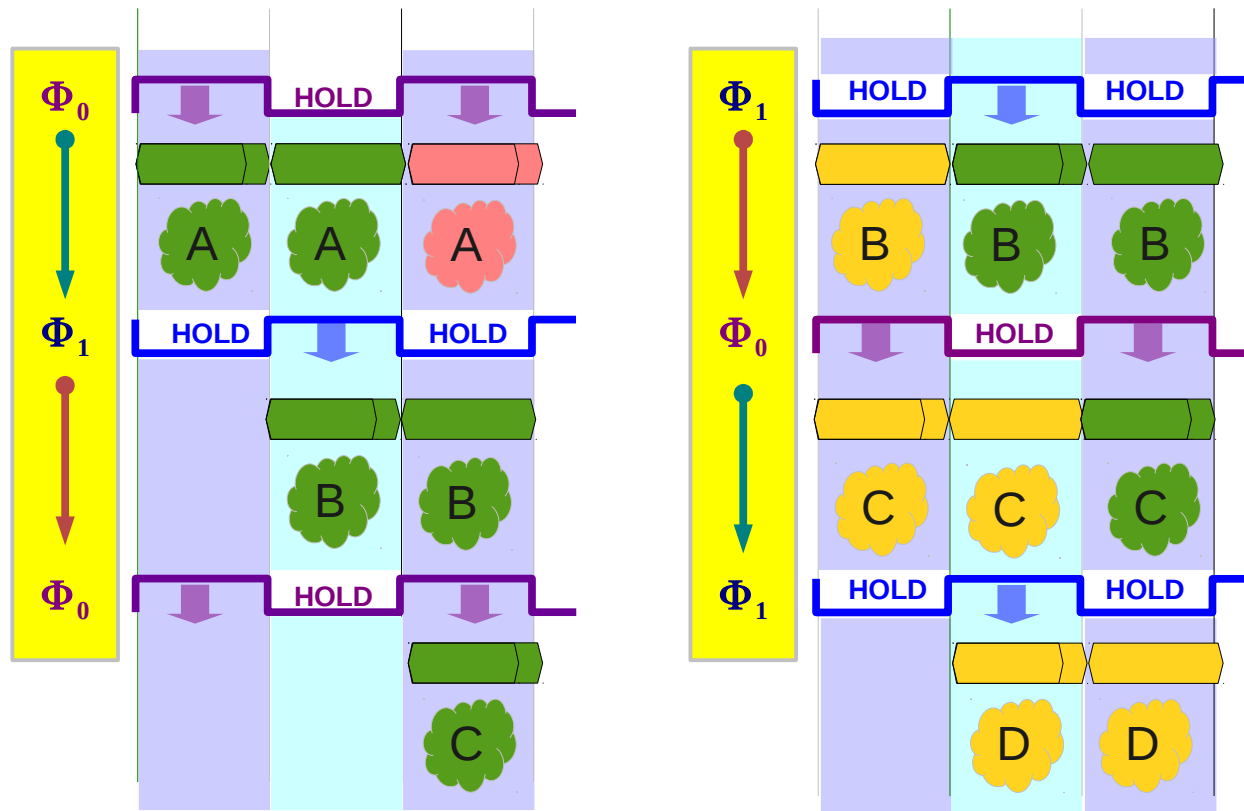

Three Adjacent Latch Timing (A)

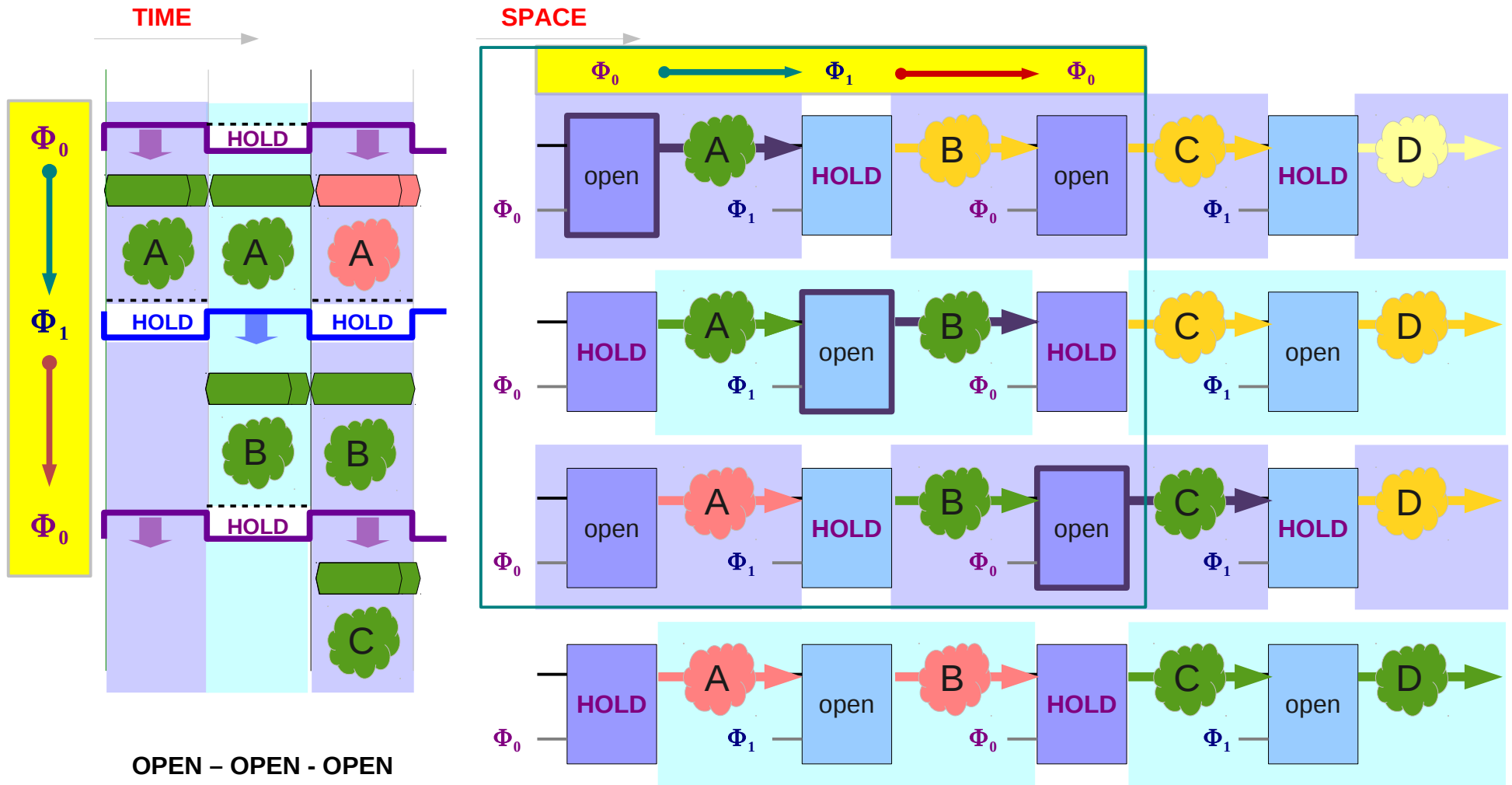

Space-Time Patterns (A1)

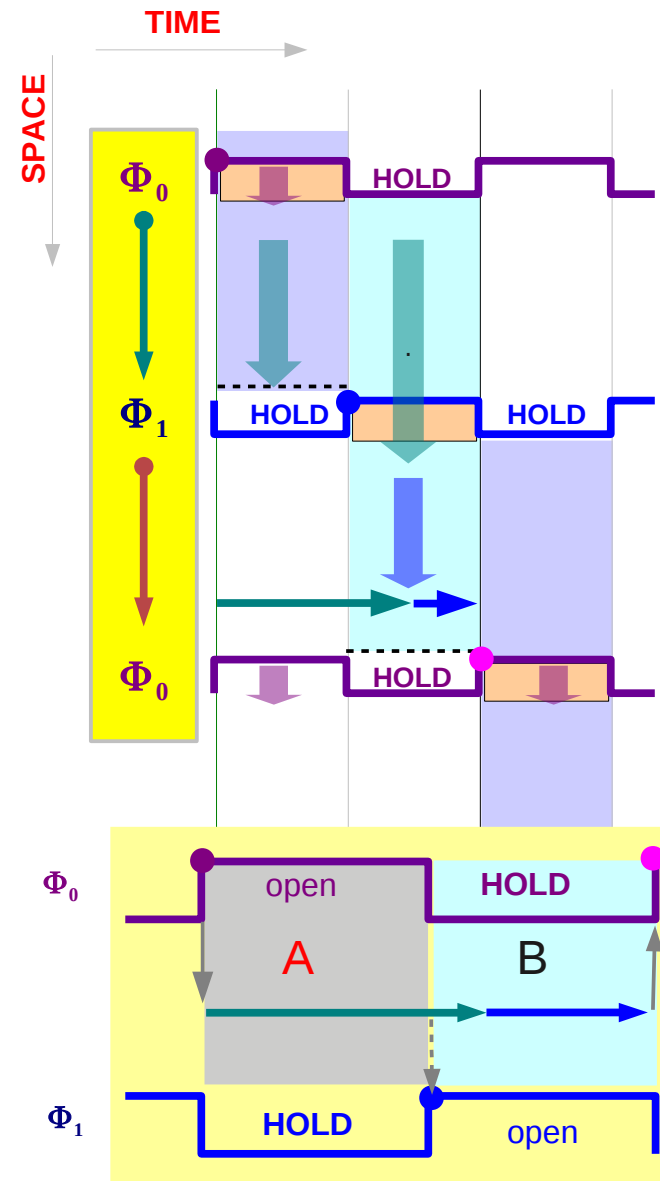
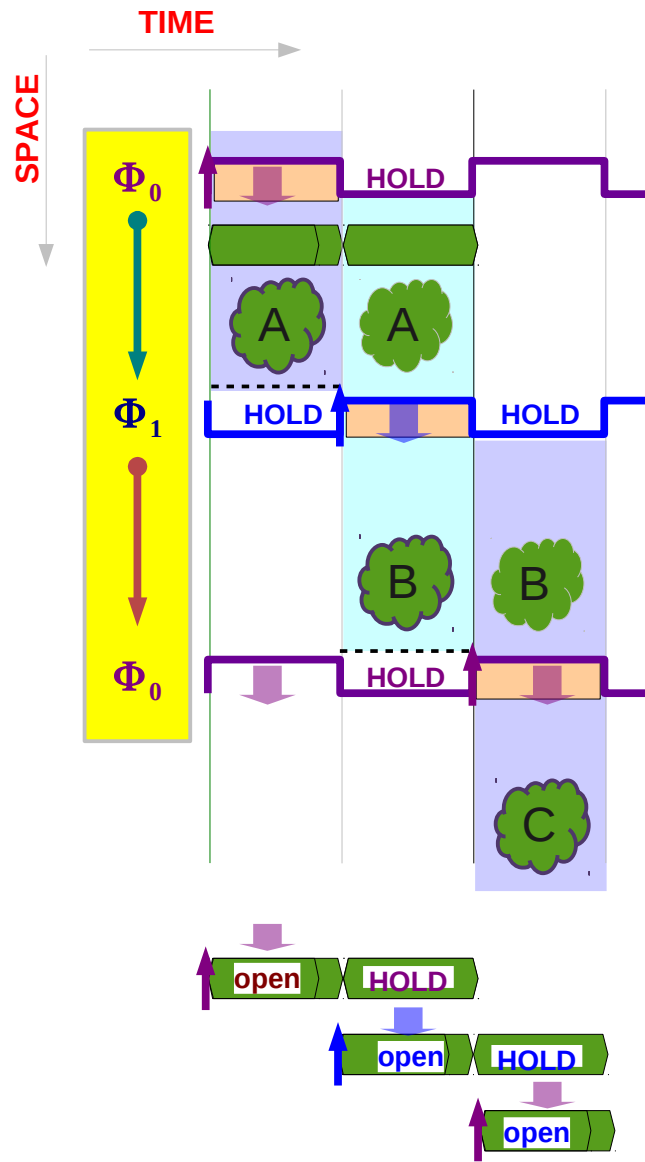

Space-Time Patterns (B1)

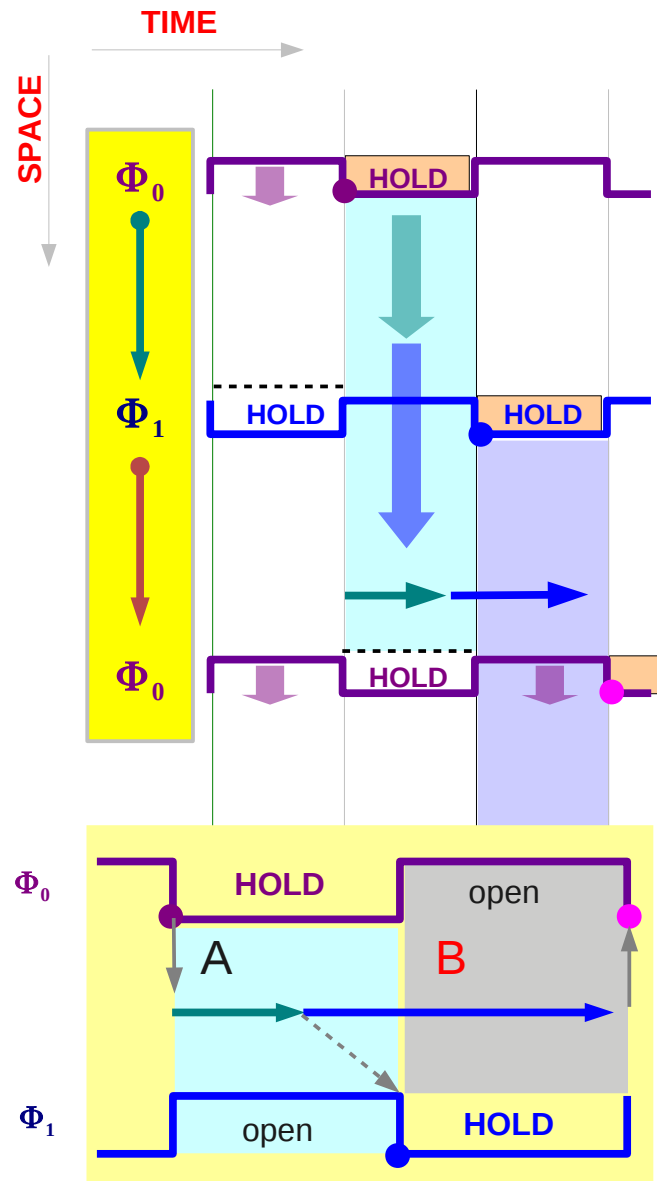
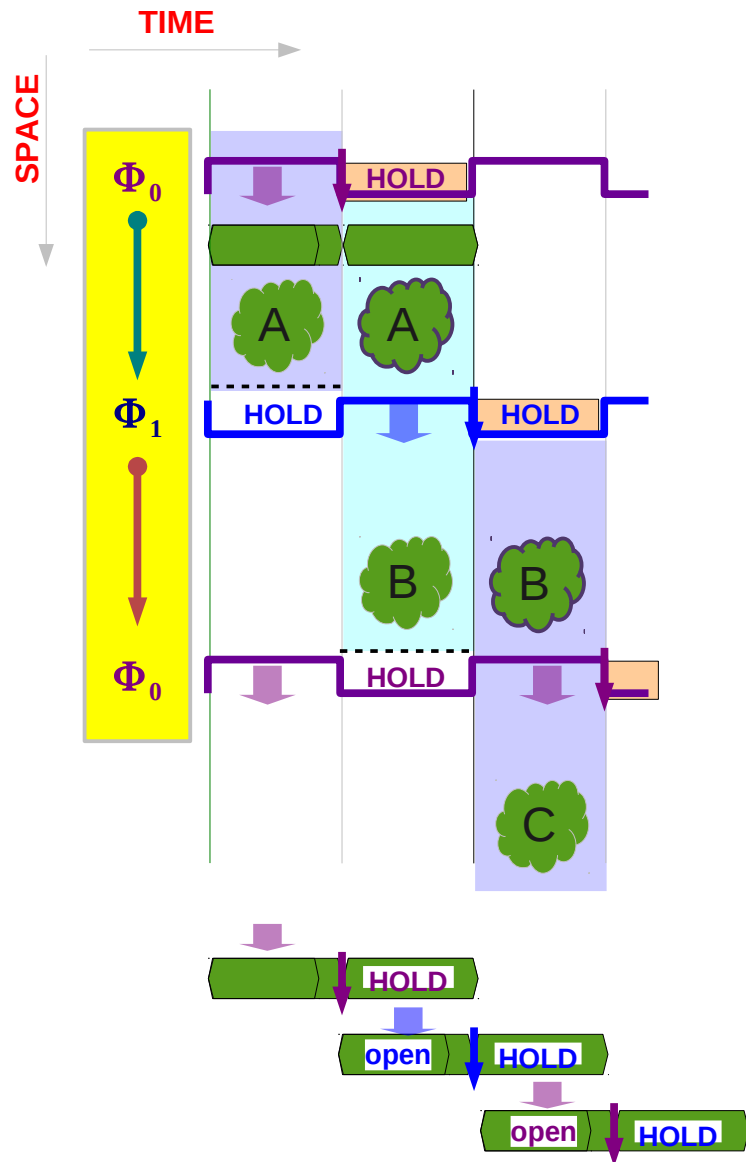

Space-Time Patterns (B2)

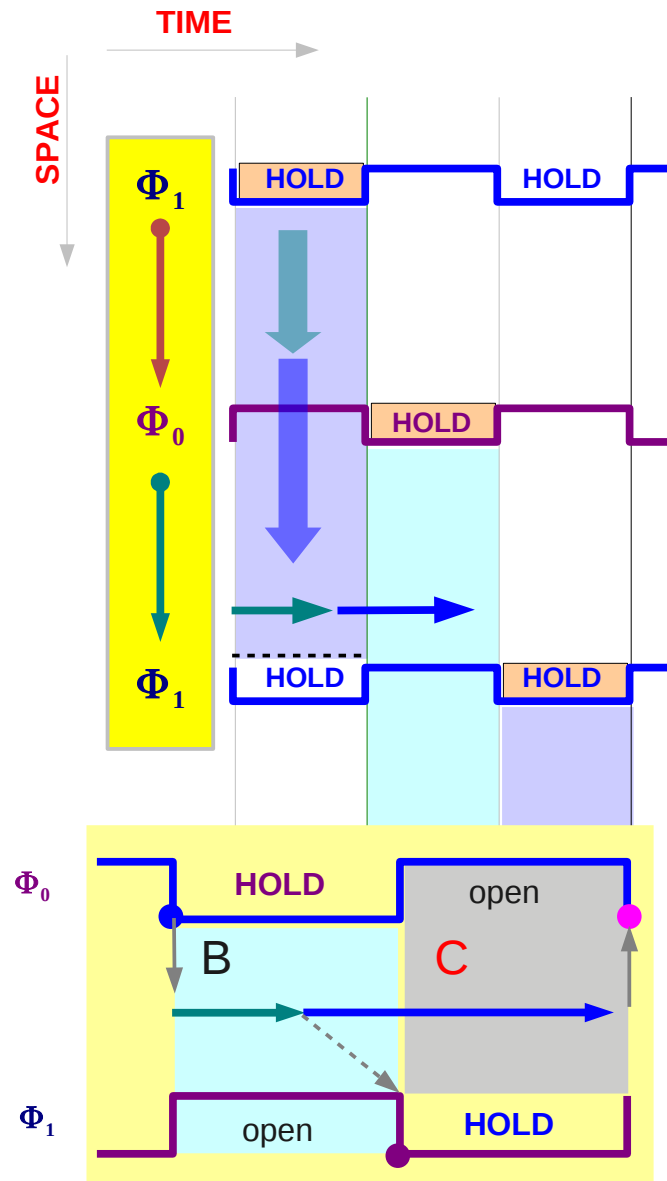
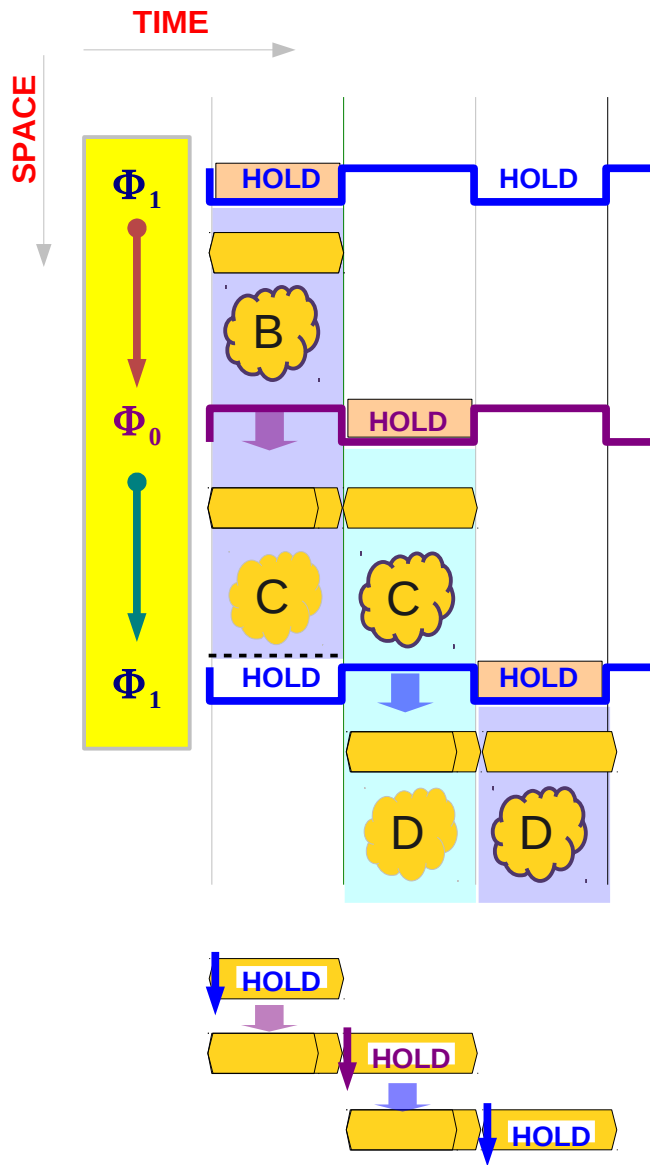

Three Adjacent Latch Timing Patterns

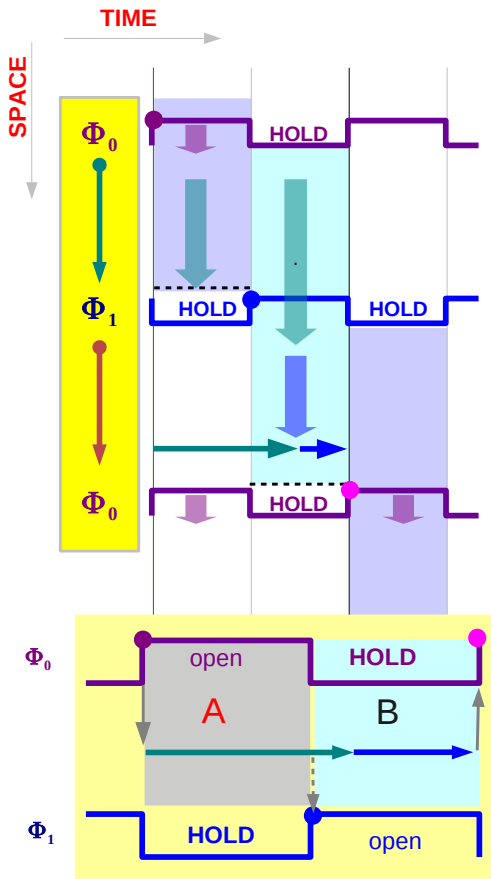
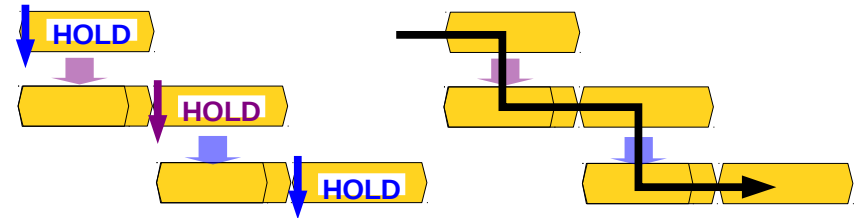
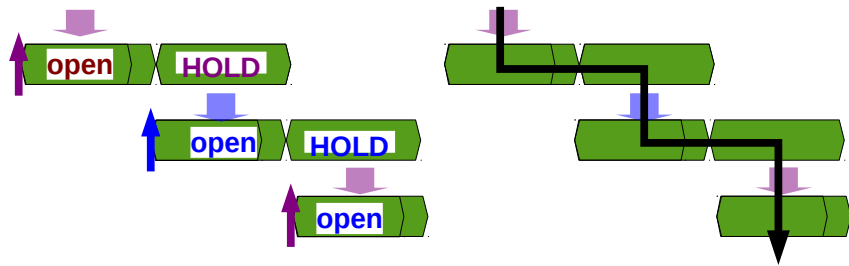

Changing Input to A begins

Computation A can spread into the next open state.

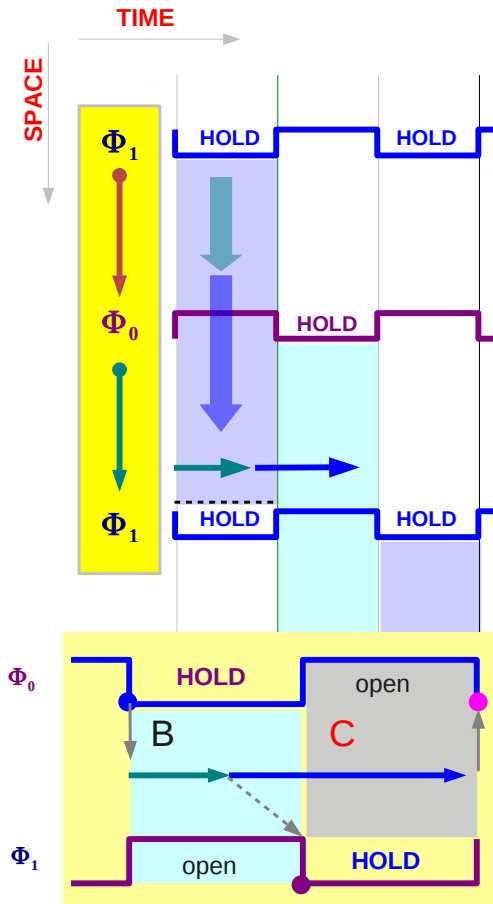

Stable Input to B begins

As soon as Comp B is ended comp C can start. This precomputation remains valid in the next hold state.

Open to Hold Transition (1)

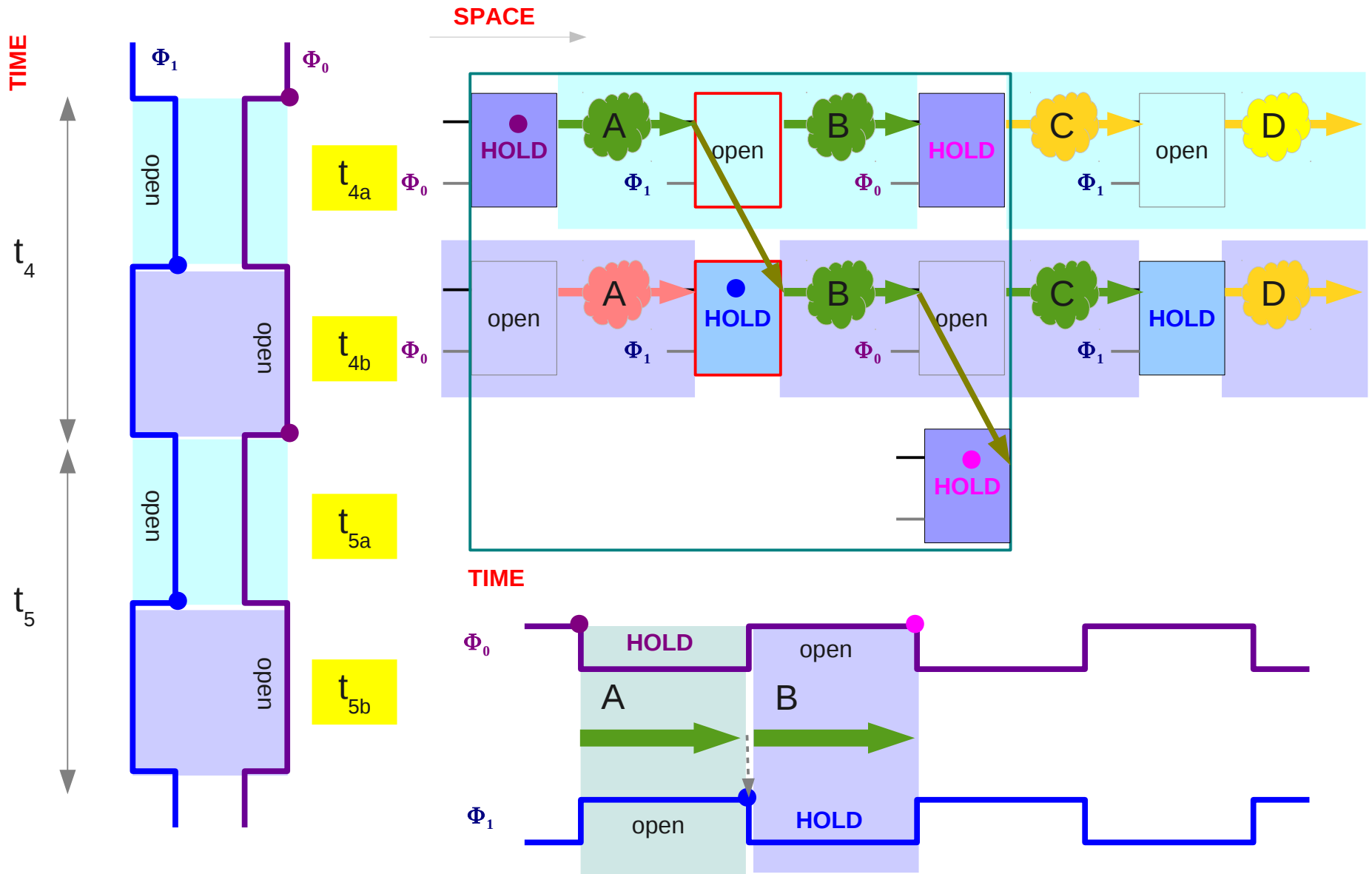

Open to Hold Transition (1)

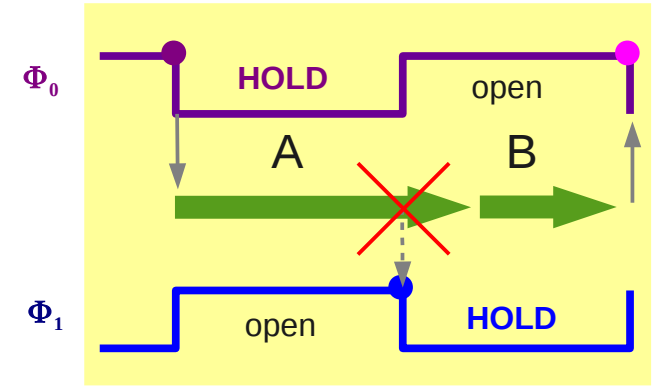
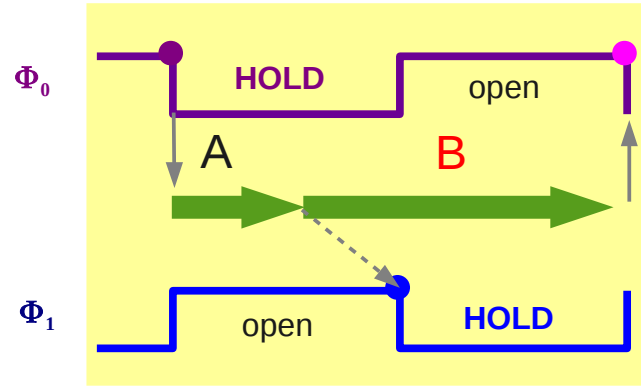
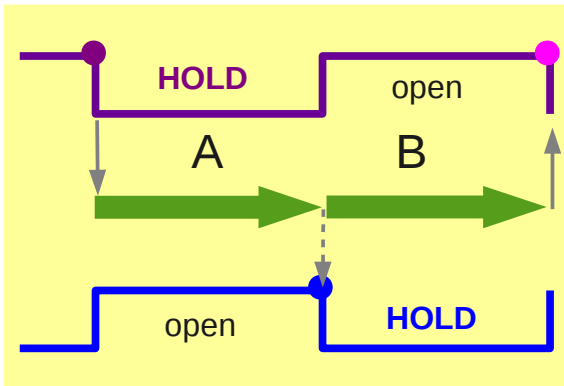
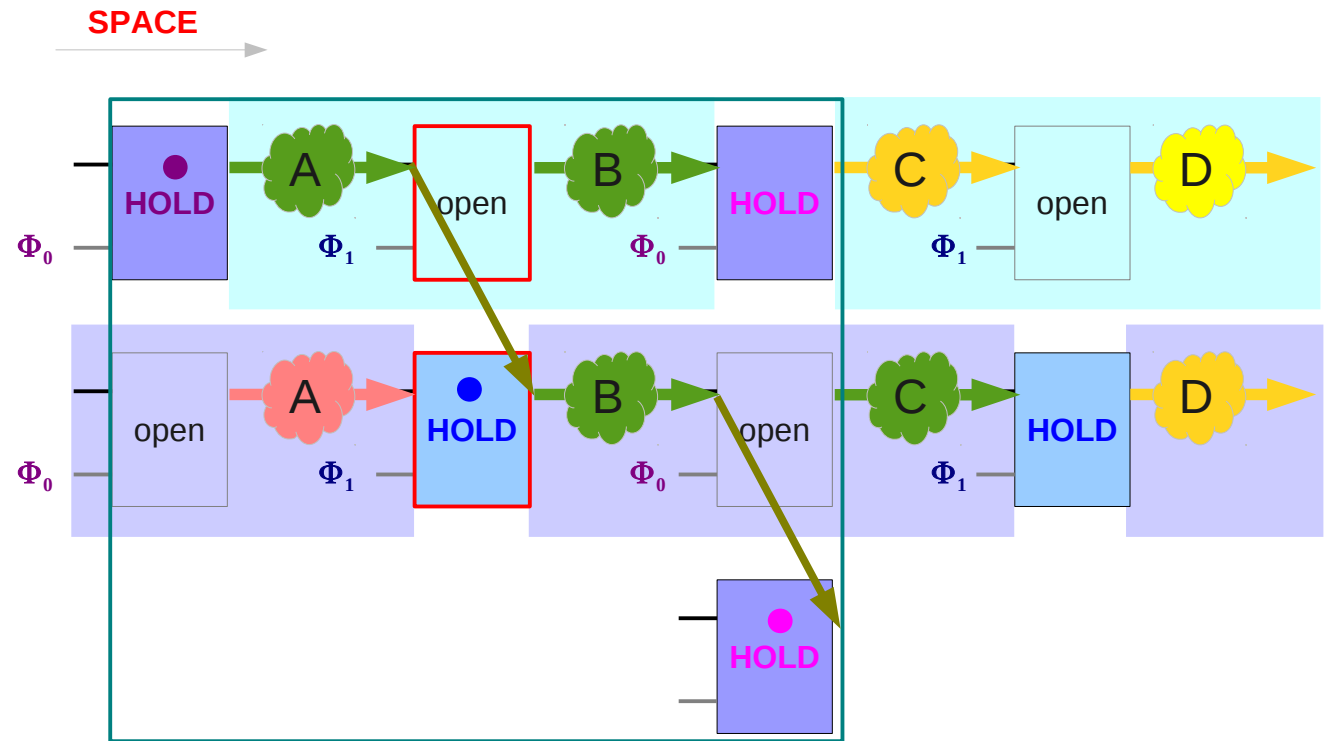

Hold to Open Transition (1)

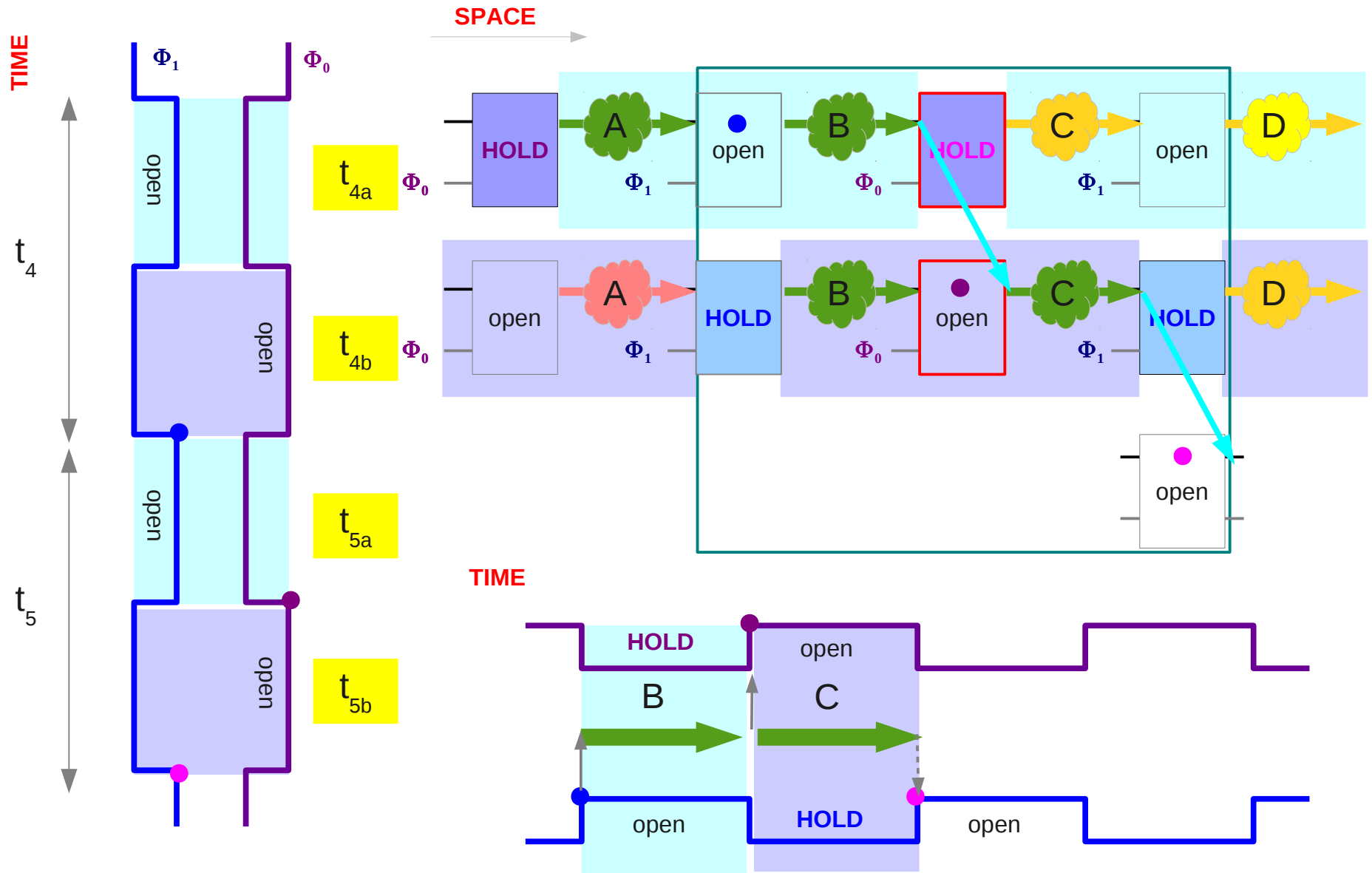

Hold to Open Transition (1)

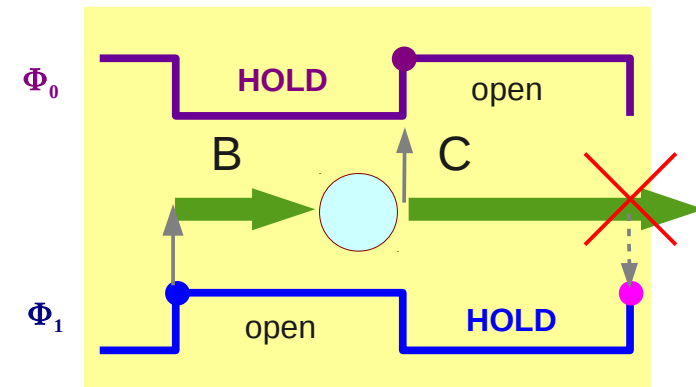
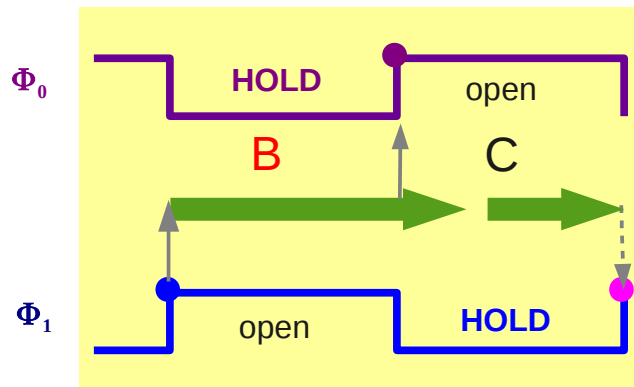
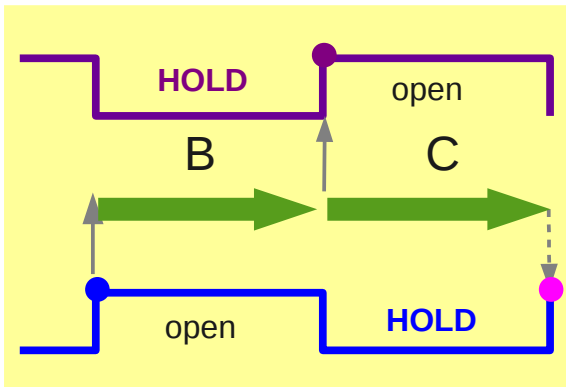
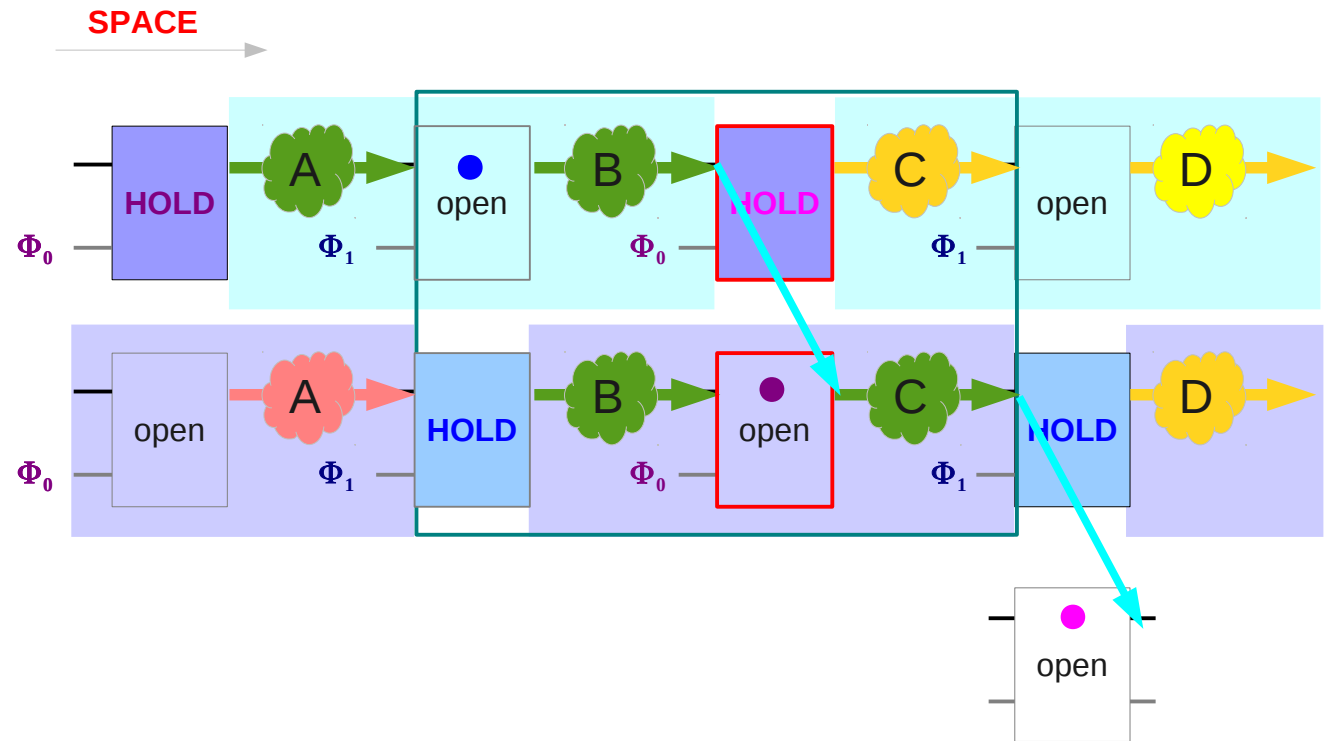

Time Borrow

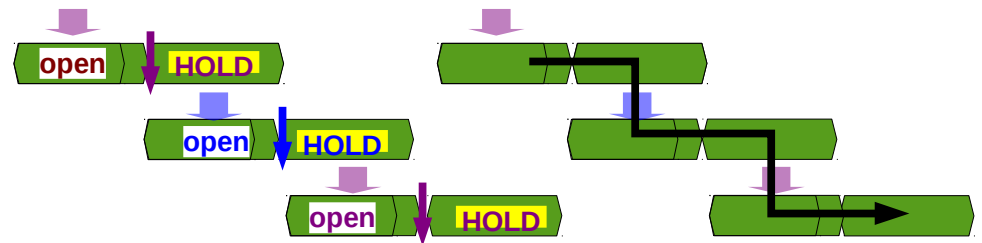
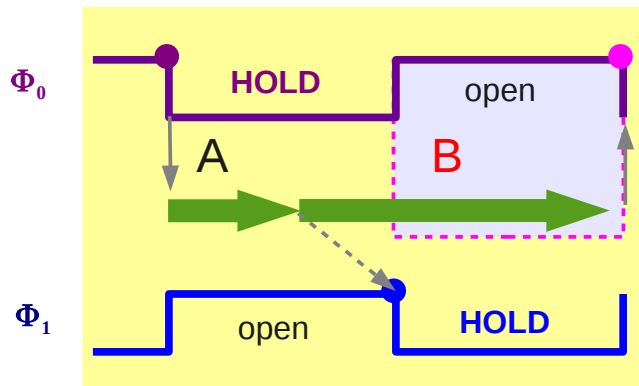
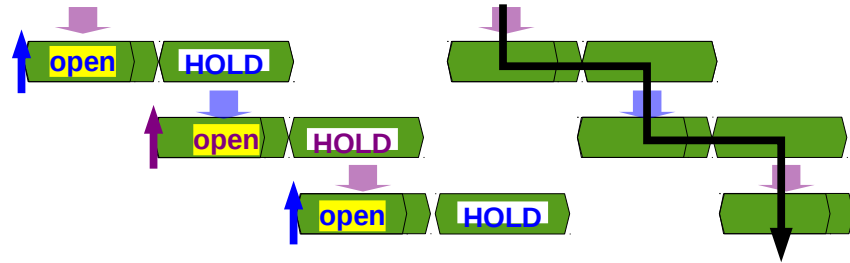
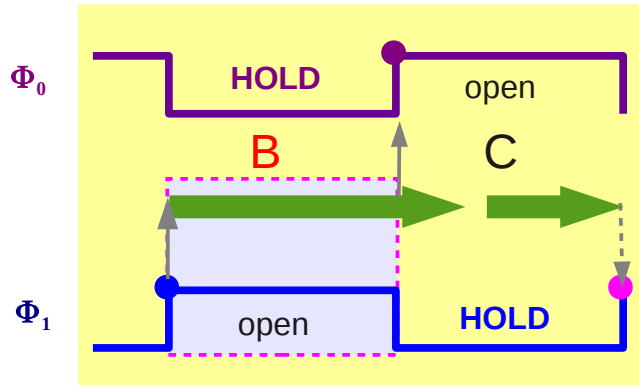

Hold to Open Transition (1)

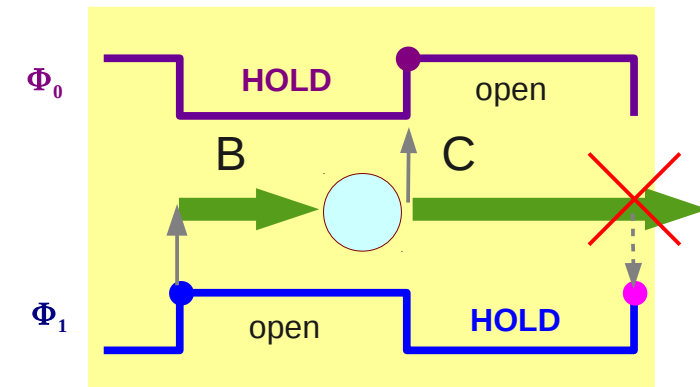
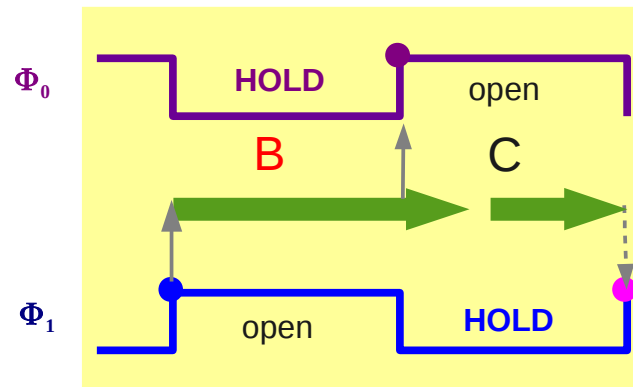
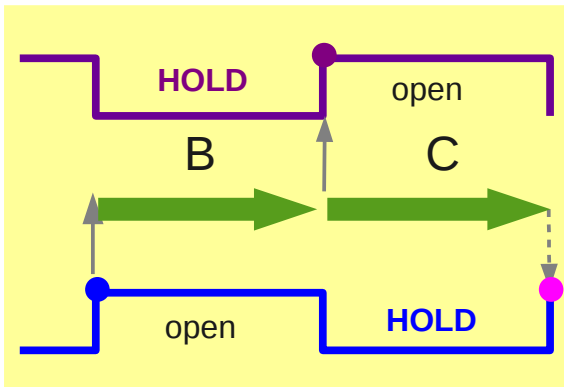
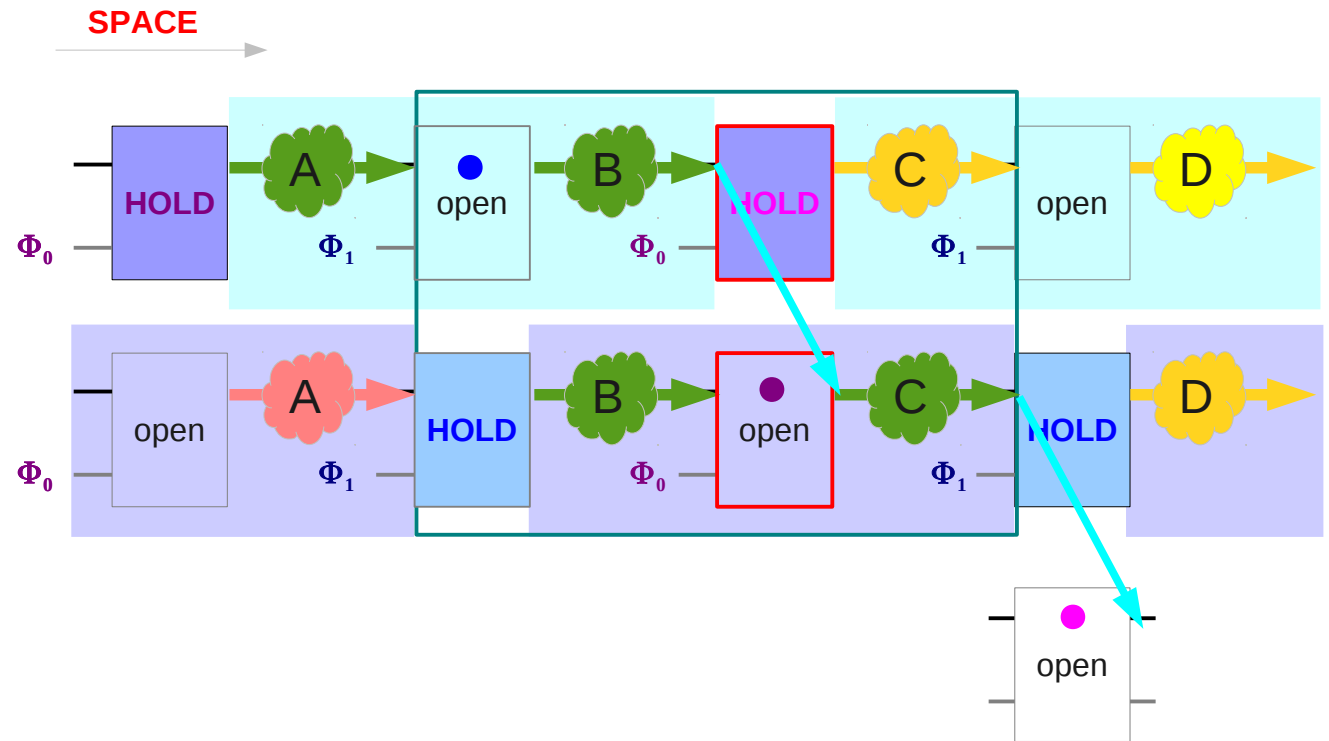

The Latch Based Pipeline Timing

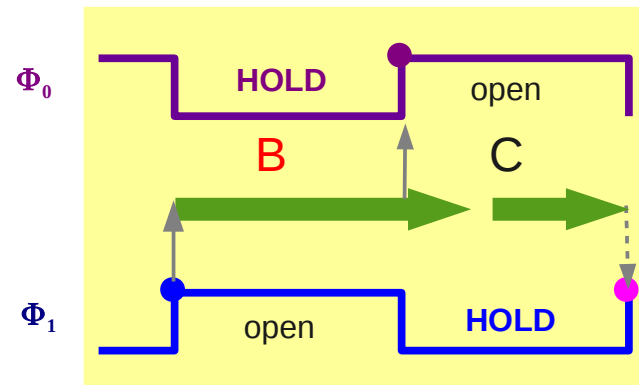
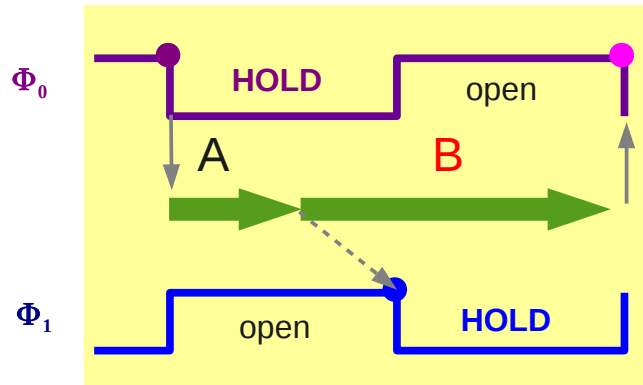
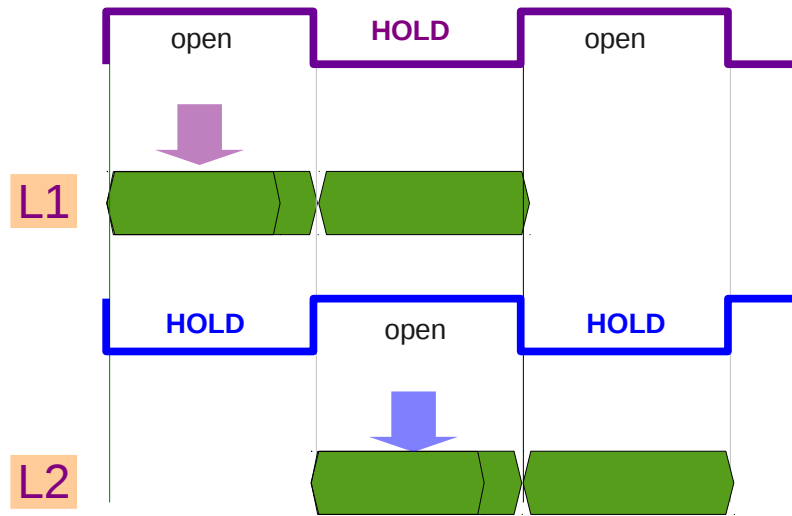

The Latch Based Pipeline Timing

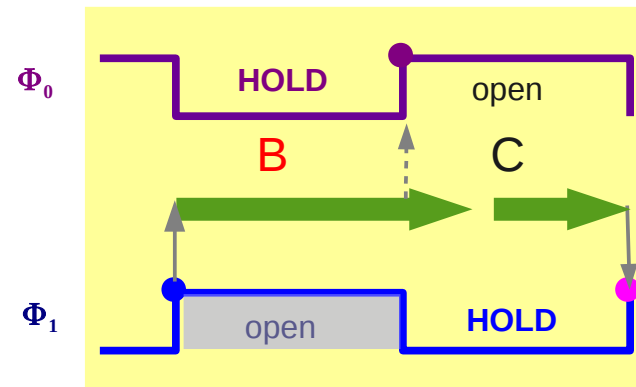
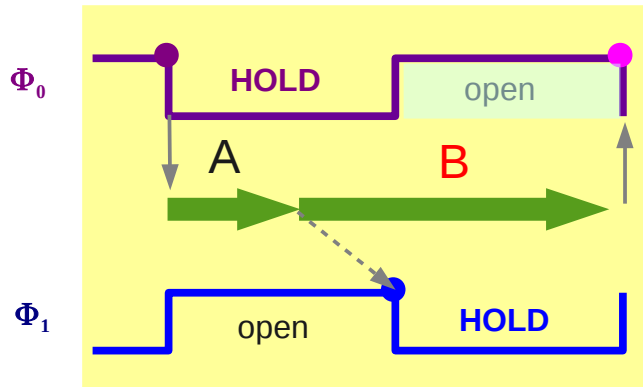
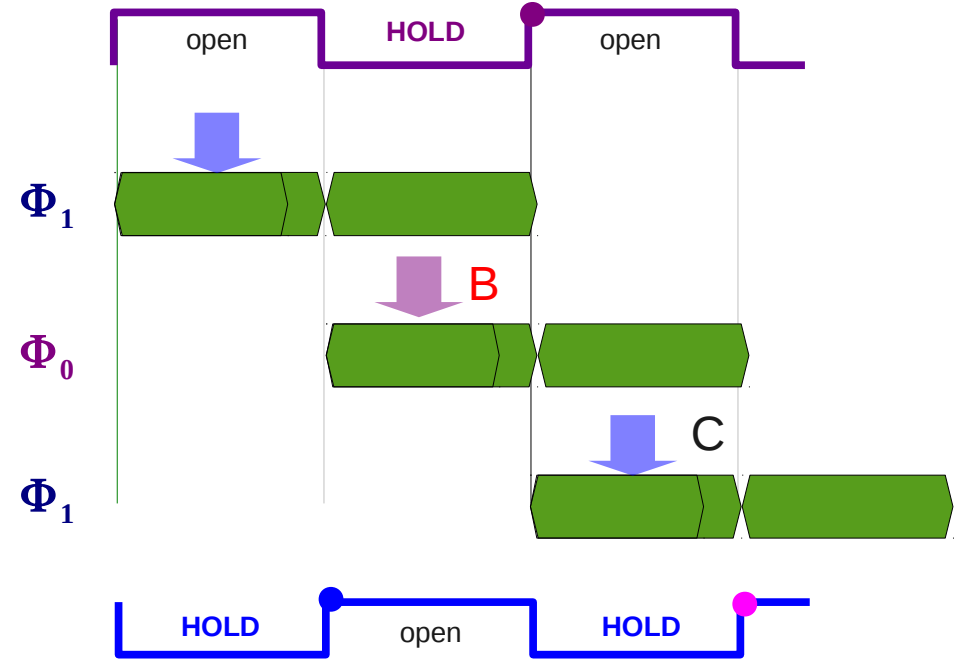
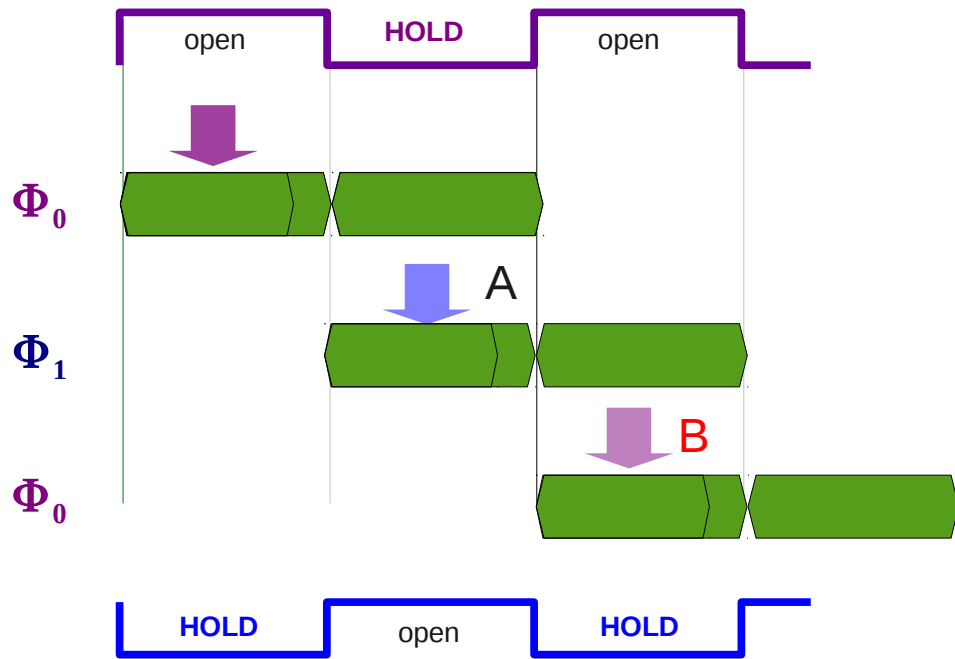

The Combinational Circuits

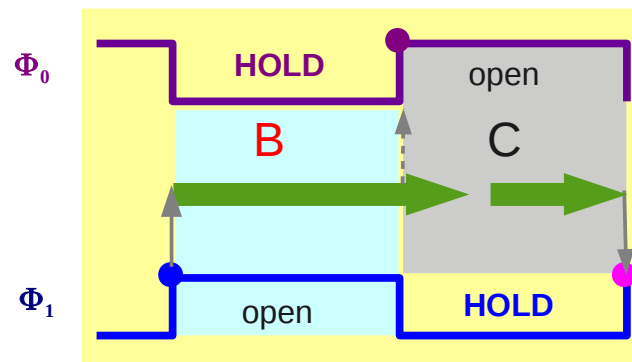
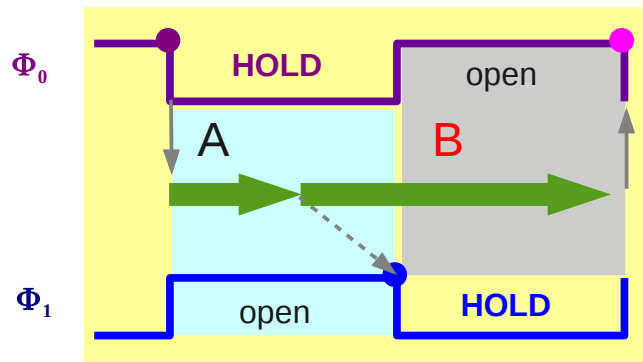
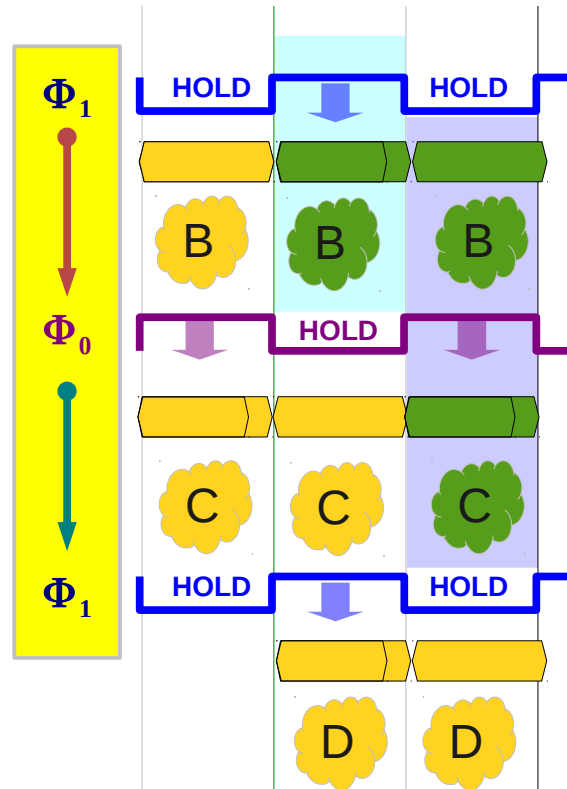
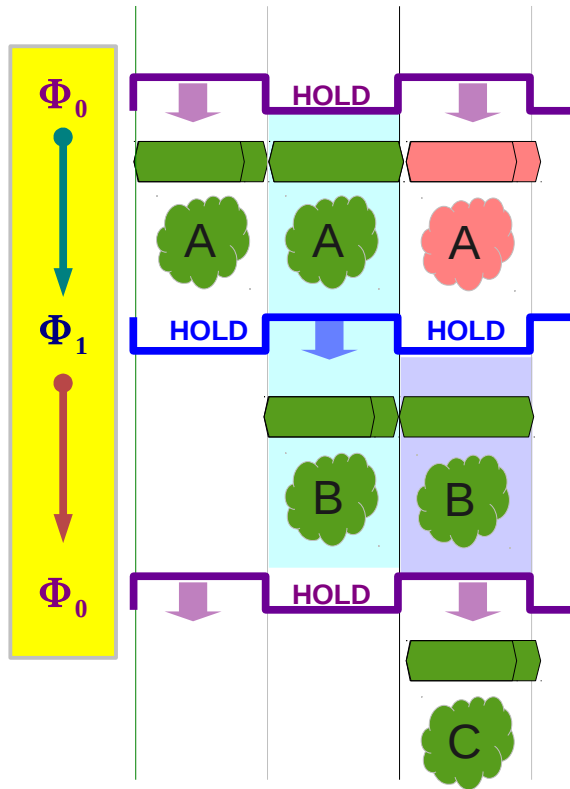

References

[1] <http://en.wikipedia.org/>