

# BJT Topologies - AC Characteristics

---

Copyright (c) 2012 - 2017 Young W. Lim.

Permission is granted to copy, distribute and/or modify this document under the terms of the GNU Free Documentation License, Version 1.2 or any later version published by the Free Software Foundation; with no Invariant Sections, no Front-Cover Texts, and no Back-Cover Texts. A copy of the license is included in the section entitled "GNU Free Documentation License".

Please send corrections (or suggestions) to [youngwlim@hotmail.com](mailto:youngwlim@hotmail.com).

This document was produced by using OpenOffice and Octave.

# CE Amplifier : Load lines

## Common Emitter

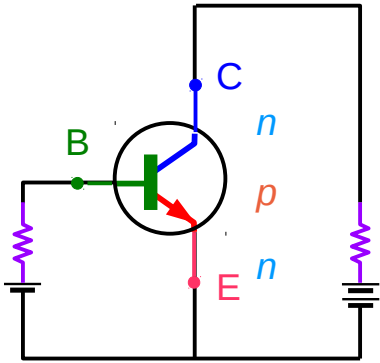

## Input Characteristics

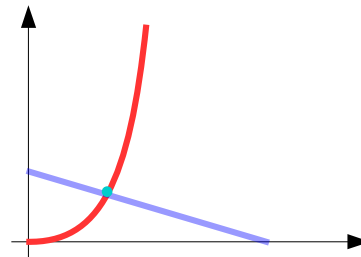

## Output Characteristics

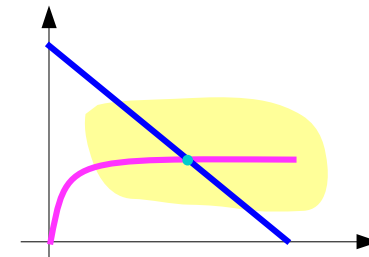

## Active region

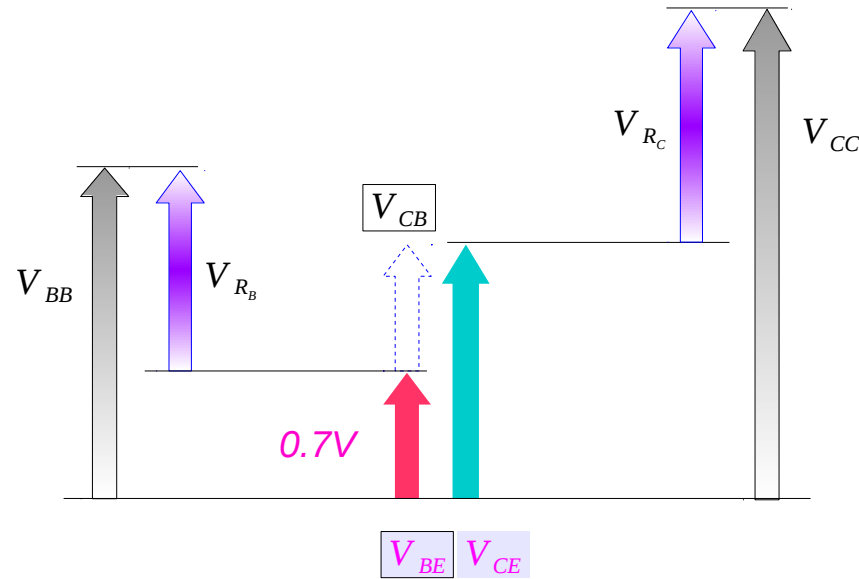
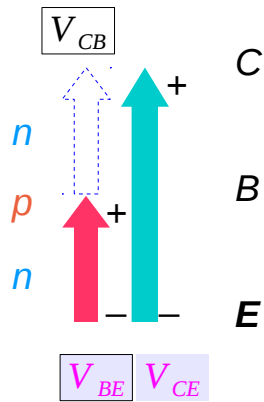

# CE Amplifier : increasing $I_B \nrightarrow$ decreasing $V_{CE}$ : Saturation

## Common Emitter

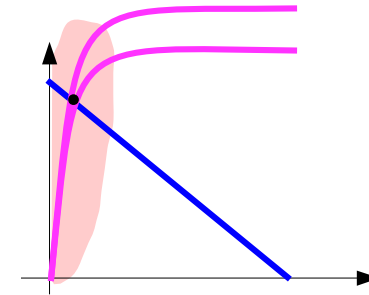
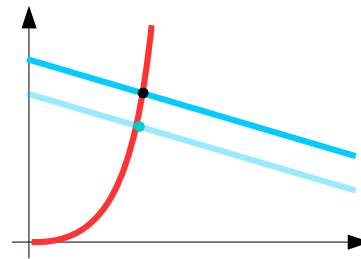
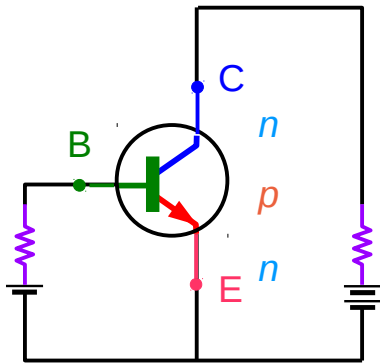

**saturation**

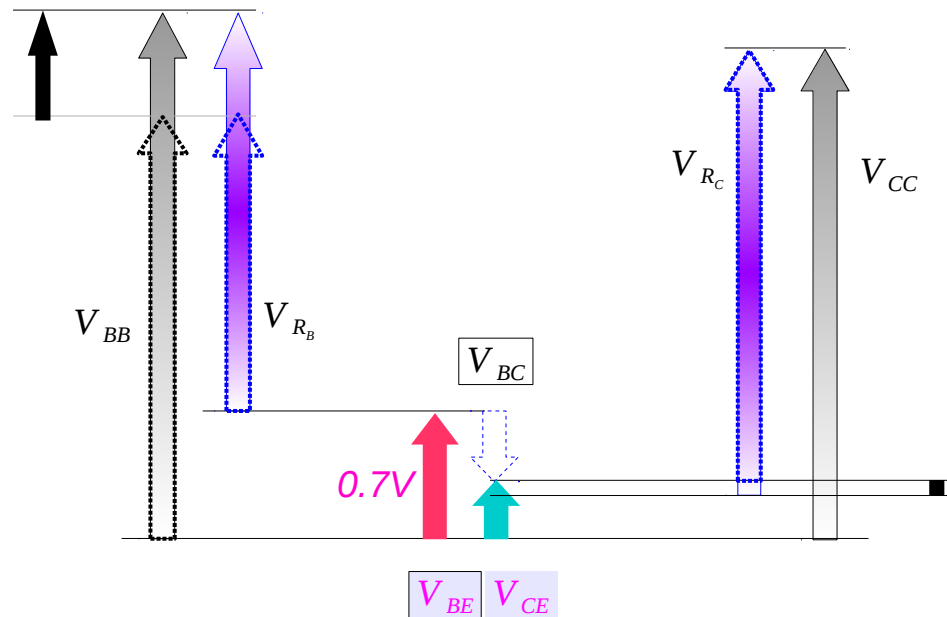
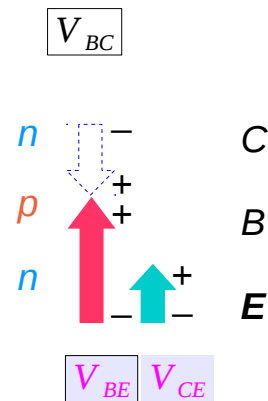

# CC Amplifier : Load lines

## Common Collector 3

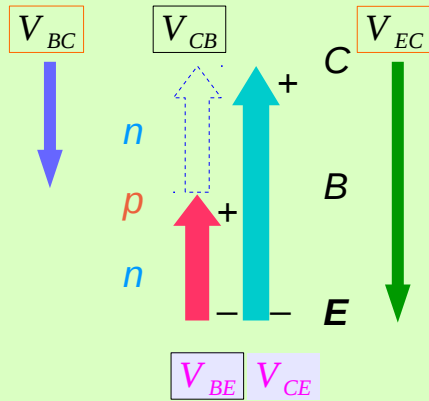
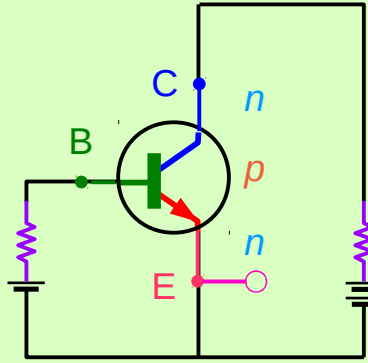

Active region

## Input Characteristics

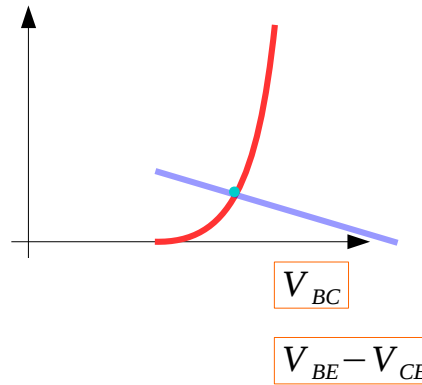
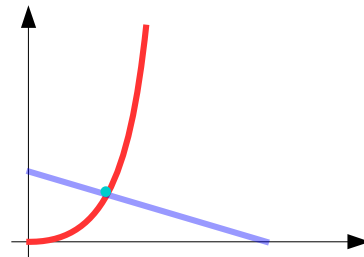

## Output Characteristics

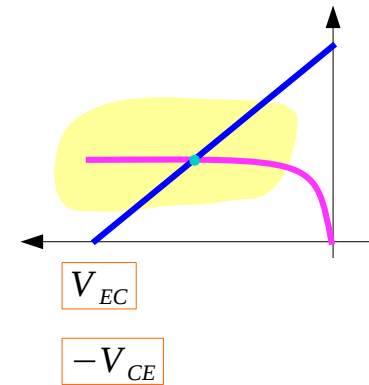
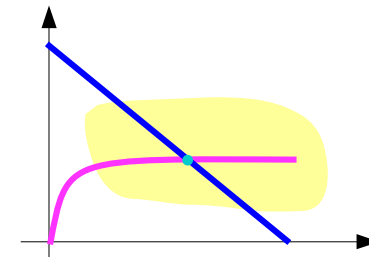

# CB Amplifier : Load lines

## Common Base

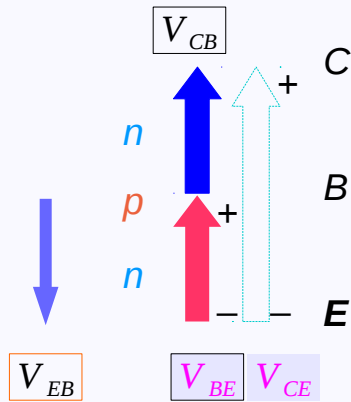
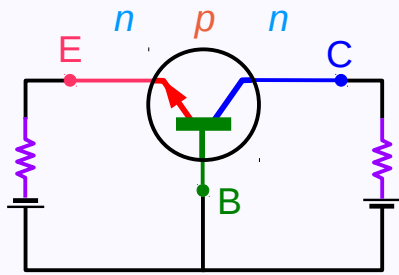

Active region

## Input Characteristics

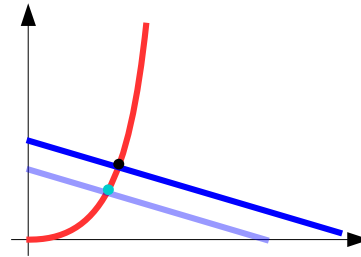

## Output Characteristics

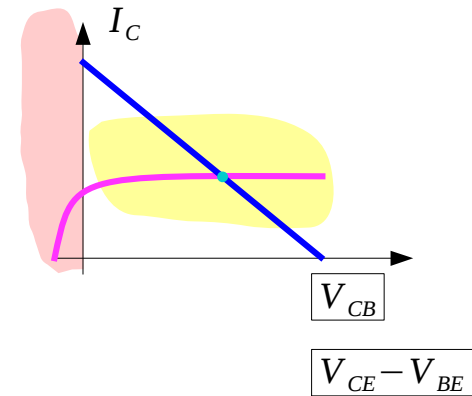
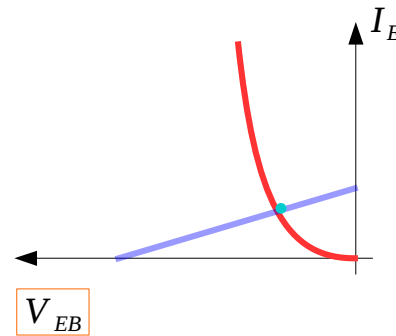
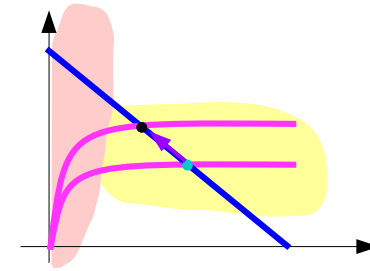

# BJT Amplifier Configurations

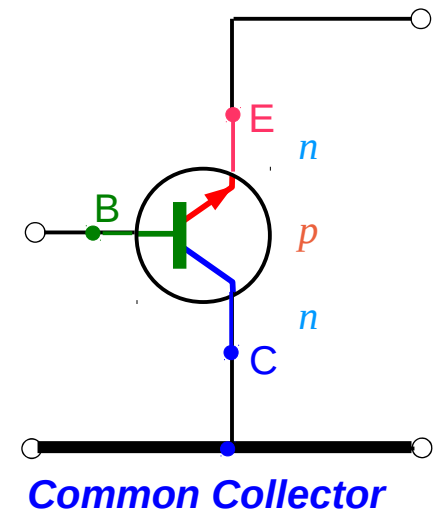
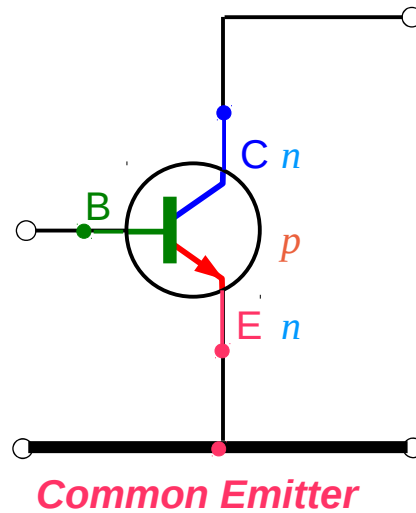
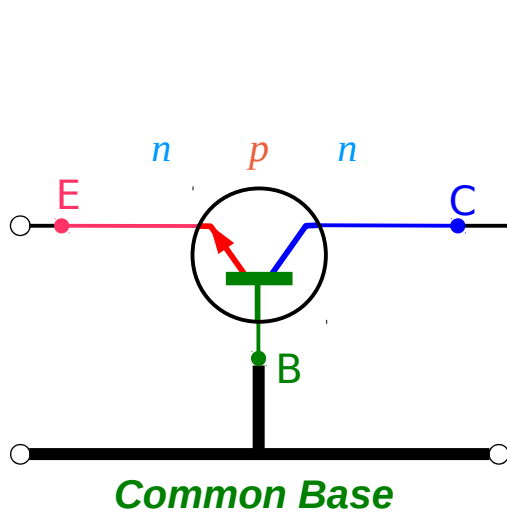
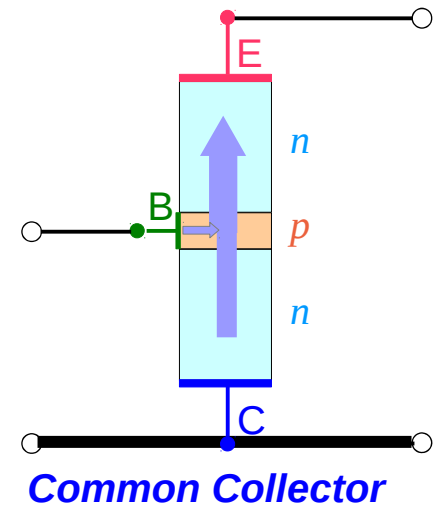
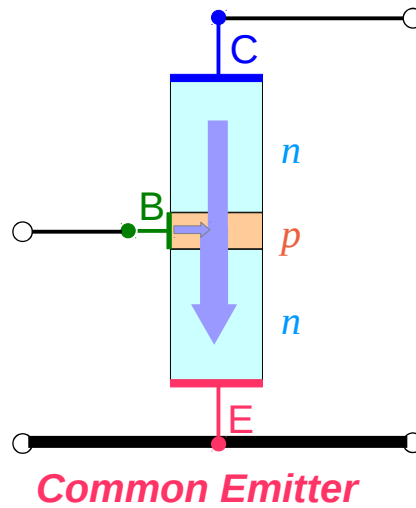
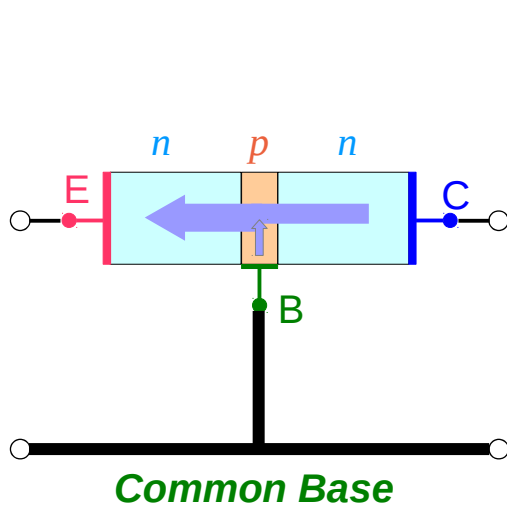

# BJT Configuration Properties

Low  $Z_{in}$   $\Rightarrow$

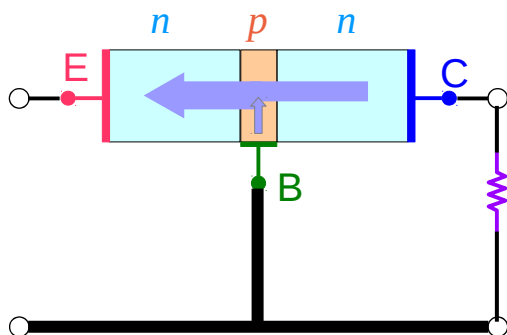

**Common Base**

input  $Z$  : low  
 output  $Z$  : high  
 voltage gain : high  
 current gain : unity

EB  
 CB

RF Applications

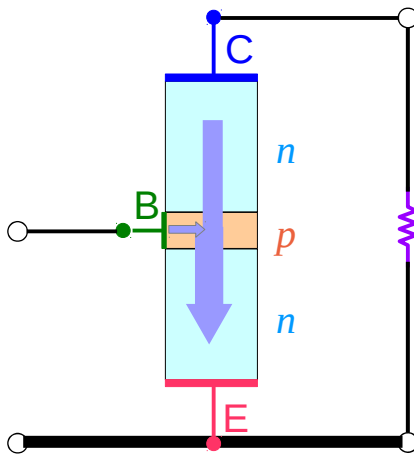

**Common Emitter**

input  $Z$  : high  
 output  $Z$  : high  
 voltage gain : high  
 current gain : high

BE  
 CE

Widely used

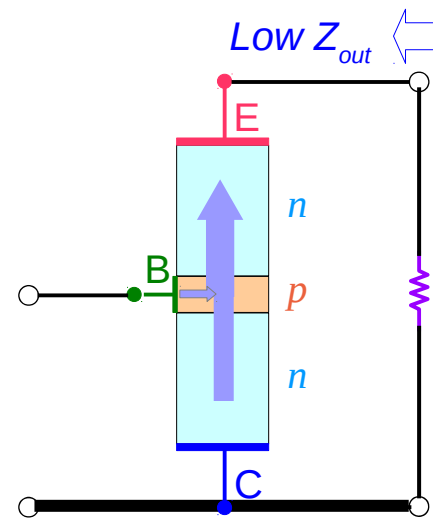

**Common Collector**

input  $Z$  : high  
 output  $Z$  : low  
 voltage gain : unity  
 current gain : high

BC  
EC

Emitter Follower  
 Buffer to  
 Low Impedance Load



# BJT Configuration Properties

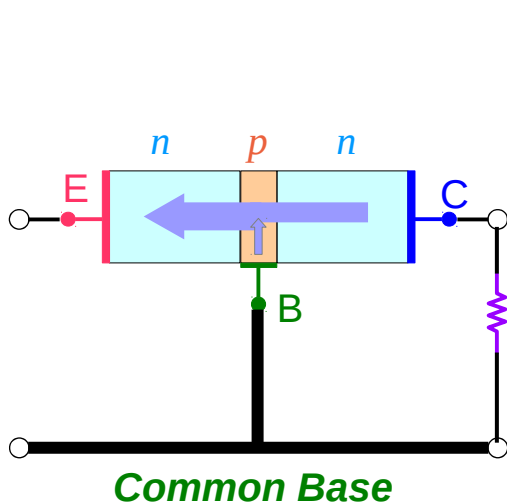

$Z_{in} : \text{low}$        $r_e'$   
 $Z_{out} : \text{high}$        $R_C$   
 $A_v : \text{high}$        $R_C/r_e'$   
 $A_i : \text{unity}$       1

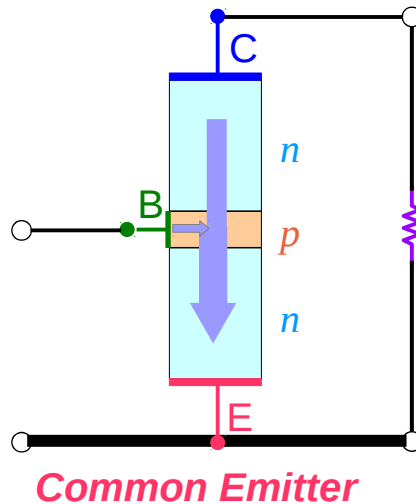

$Z_{in} : \text{high}$        $\beta r_e'$   
 $Z_{out} : \text{high}$        $R_C$   
 $A_v : \text{high}$        $R_C/r_e'$   
 $A_i : \text{high}$        $\beta$

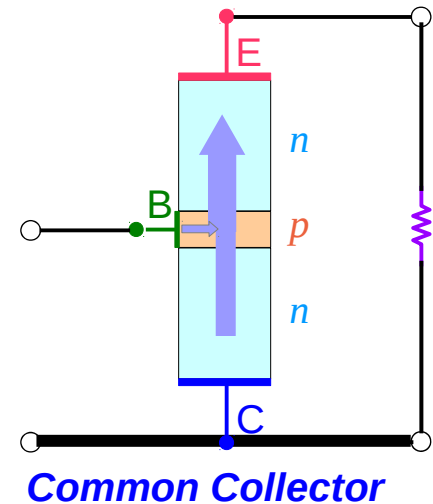

$Z_{in} : \text{high}$        $\beta(r_e' + R_E)$   
 $Z_{out} : \text{low}$        $r_e'$   
 $A_v : \text{unity}$       1  
 $A_i : \text{high}$        $\beta$

# Input Impedance $Z_{in}$

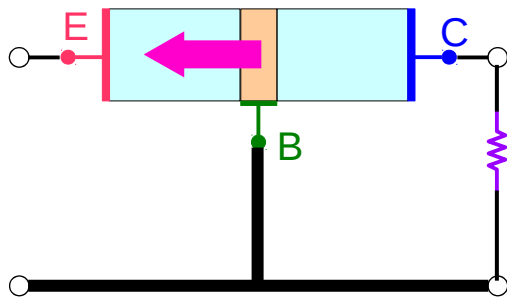

Common Base

$Z_{in}$  : low  $r_e'$

$I_e$  : Large

$I_e$

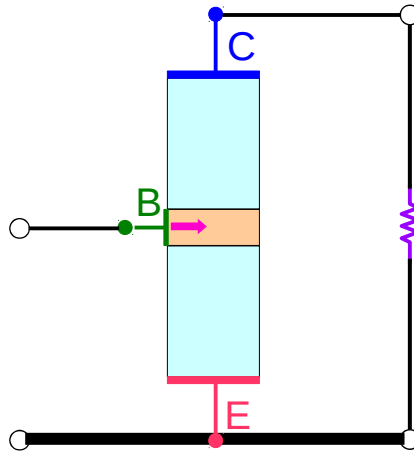

Common Emitter

$Z_{in}$  : high  $\beta r_e'$

$I_b$  : Small

$I_b$

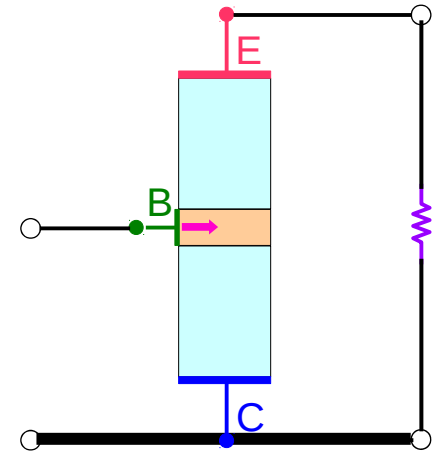

Common Collector

$Z_{in}$  : high  $\beta(r_e' + R_E)$

$I_b$  : Small

$I_b$

# Output Impedance $Z_{in}$

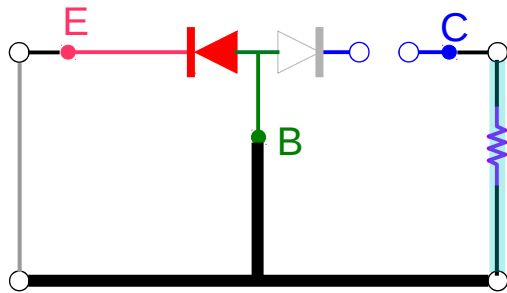

Common Base

$Z_{out} : \text{high } R_C$

Thevenin  $R$

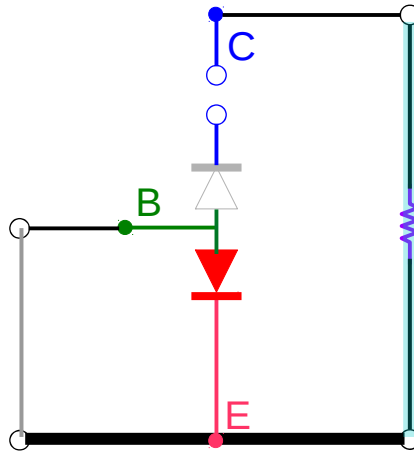

Common Emitter

$Z_{out} : \text{high } R_C$

Thevenin  $R$

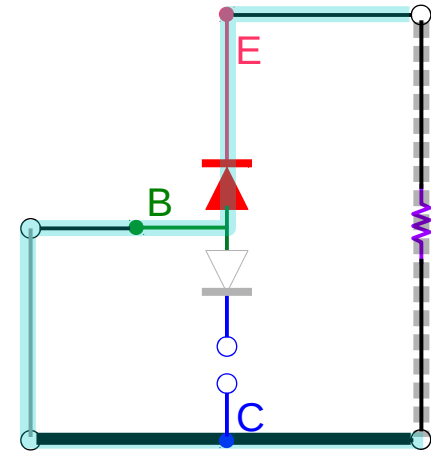

Common Collector

$Z_{out} : \text{low } r_e'$

Thevenin  $R$

# Voltage Gain $A_v$

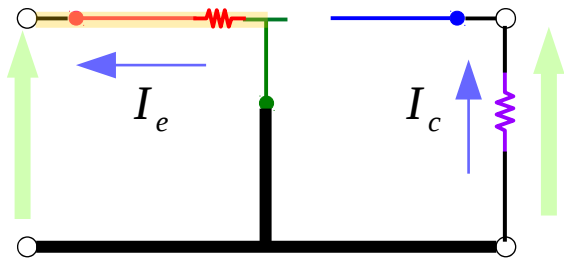

Common Base

$A_v : \text{high } R_C/r_e'$

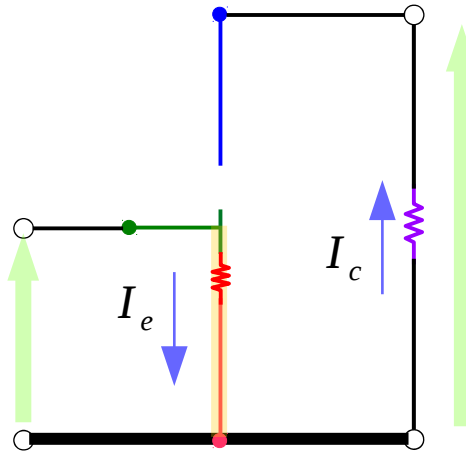
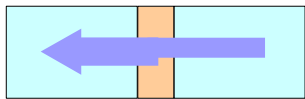

Common Emitter

$A_v : \text{high } R_C/r_e'$

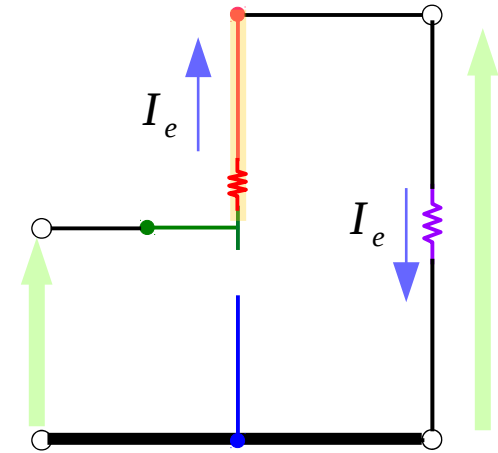
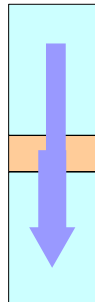

Common Collector

$A_v : \text{unity } 1$

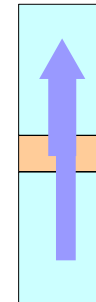

# Current Gain $A_i$

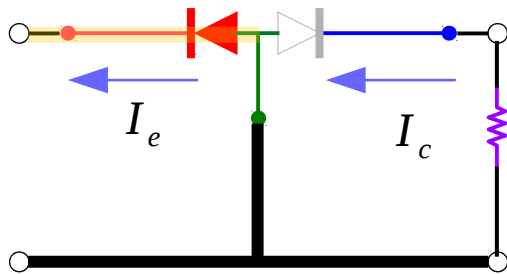

Common Base

$A_i$  : unity    1

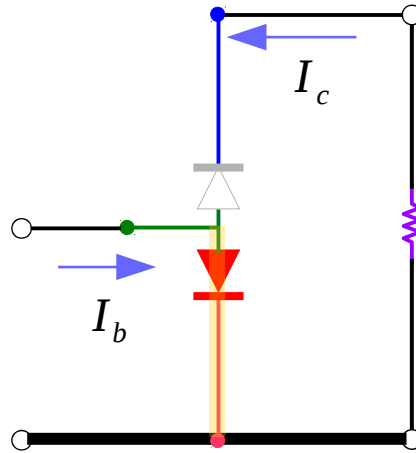

Common Emitter

$A_i$  : high     $\beta$

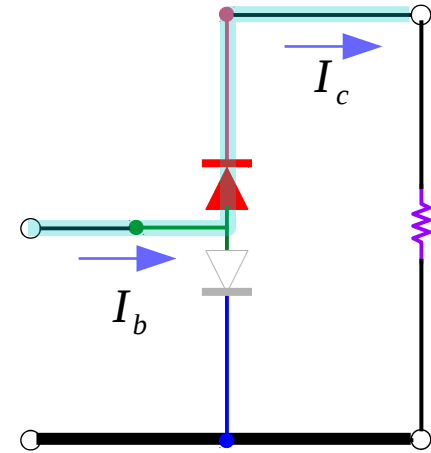

Common Collector

$A_i$  : high     $\beta$

# BJT Configuration Properties

## Common Base

## Common Emitter

## Common Collector

$Z_{in}$	CB : low	$r_e'$	CE : high	$\beta r_e'$	CC : high	$\beta(r_e' + r_E)$
$Z_{out}$	CB : high	$R_C$	CE : high	$R_C$	CC : low	$r_e'$
$A_v$	CB : high	$R_C/r_e'$	CE : high	$R_C/r_e'$	CC : unity	1
$A_i$	CB : unity	1	CE : high	$\beta$	CC : high	$\beta$



$Z_{in}$	CB : low	$r_e'$	CE : high	$\beta r_e'$	CC : high	$\beta(r_e' + R_E)$
$Z_{out}$	CC : low	$r_e'$	CE : high	$R_C$	CB : high	$R_C$
$A_v$	CC : unity	1	CE : high	$R_C/r_e'$	CB : high	$R_C/r_e'$
$A_i$	CB : unity	1	CE : high	$\beta$	CC : high	$\beta$

# BJT Configuration Properties

	<b>Common Base</b>	<b>Common Emitter</b>	<b>Common Collector</b>
$Z_{in}$	CB : low $r_e'$	CE : high $\beta r_e'$	CC : high $\beta(r_e' + r_E)$
$Z_{out}$	CB : high $R_C$	CE : high $R_C$	CC : low $r_e'$
$A_v$	CB : high $R_C/r_e'$	CE : high $R_C/r_e'$	CC : unity 1
$A_i$	CB : unity 1	CE : high $\beta$	CC : high $\beta$

	<b>Common Base</b>	<b>Common Emitter</b>	<b>Common Collector</b>
$Z_{in}$	CB : low $r_e$	CE : med $r_{\pi} = (\beta + 1)r_e$	CC : high $(\beta + 1)[r_e + (r_o    R_L)]$
$Z_{out}$	CB : high $R_C$	CE : med $R_C    r_o$	CC : low $r_o    [r_e + \frac{R_s}{\beta + 1}]$
$A_v$	CB : high $\frac{\alpha R_C}{(R_s + r_e)}$	CE : med $\frac{\beta(R_C    r_o)}{(R_s + r_{\pi})}$	CC : unity $\frac{(\beta + 1)(R_L    r_o)}{R_s + (\beta + 1)[r_e + (R_L    r_o)]}$
$A_i$	CB : unity $\alpha$	CE : med $\frac{\beta r_o}{(R_c + r_o)}$	CC : high $\frac{(\beta + 1)r_o}{r_o + R_L}$

$r_o, R_s, R_E$  are used

# BJT Configuration Properties

## Common Base

## Common Emitter

## Common Collector

$Z_{in}$	CB : low	$r_e'$	CE : high	$\beta r_e'$	CC : high	$\beta(r_e' + r_E)$
$Z_{out}$	CB : high	$R_C$	CE : high	$R_C$	CC : low	$r_e'$
$A_v$	CB : high	$R_C/r_e'$	CE : high	$R_C/r_e'$	CC : unity	1
$A_i$	CB : unity	1	CE : high	$\beta$	CC : high	$\beta$

## Common Base

## Common Emitter

## Common Collector

$Z_{in}$	CB : low	$r_e \parallel R_E \approx r_e$	CE : med	$R_1 \parallel R_2 \parallel \beta r_e$	CC : high	$R_1 \parallel R_2 \parallel \beta(r_e + R_E)$
$Z_{out}$	CB : high	$R_C$	CE : med	$R_C$	CC : low	$(r_e + \frac{R_s}{\beta}) \parallel R_E = \frac{R_s}{\beta} \parallel R_E$
$A_v$	CB : high	$\frac{R_C}{r_e}, \frac{R_C \parallel R_L}{r_e}$	CE : med	$\frac{R_C}{r_e}, \frac{R_C \parallel R_L}{r_e}$	CC : unity	$\frac{R_E}{(r_e + R_E)} \approx 1$
$A_i$	CB : unity		CE : med		CC : high	

VDB



# BJT Configuration Properties

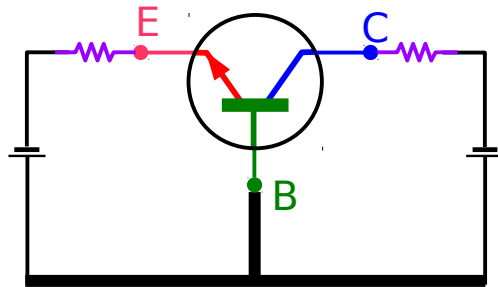

*Common Base*

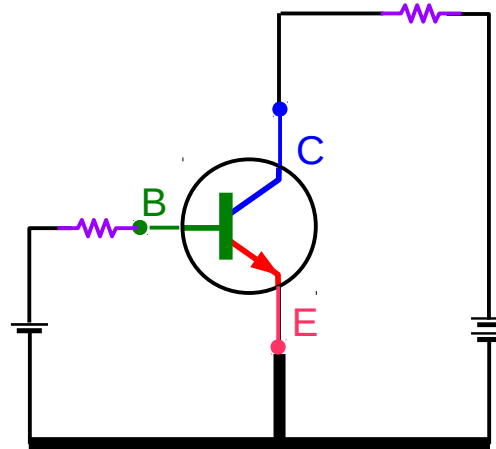

*Common Emitter*

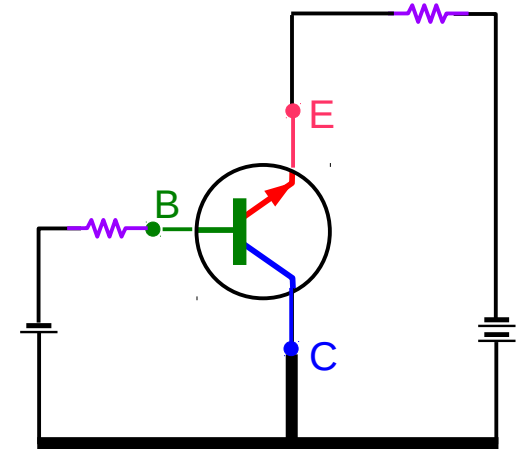

*Common Collector*

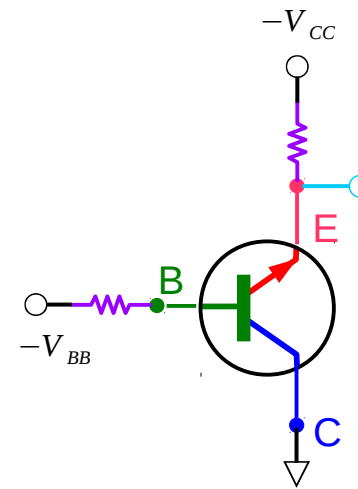
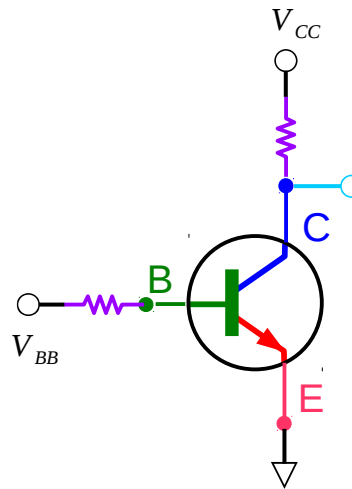
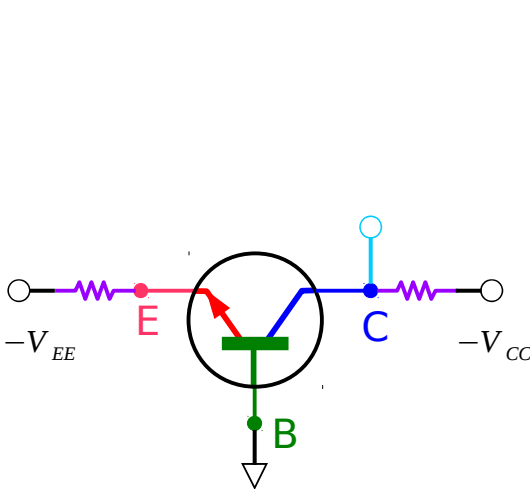



# DC Bias

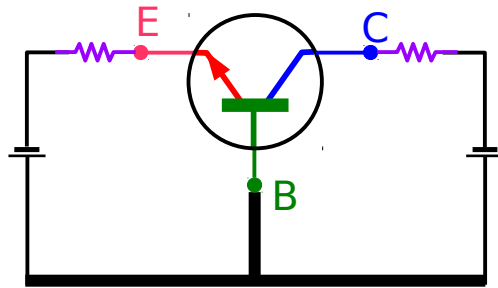

*Common Base*

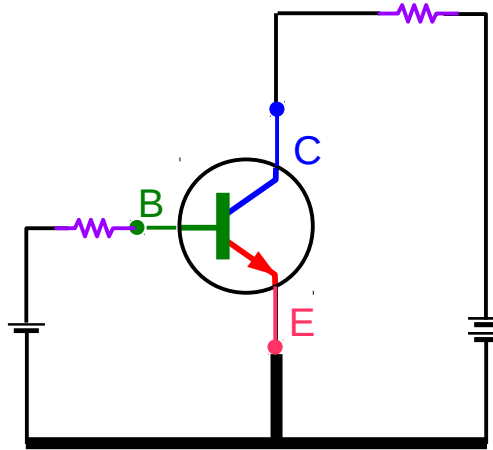

*Common Emitter*

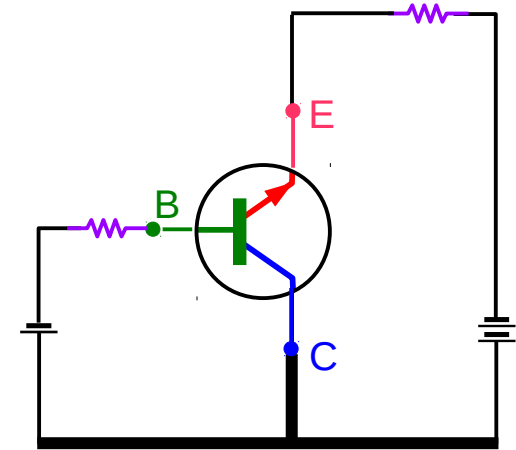

*Common Collector*

# DC Bias + AC Small Signal

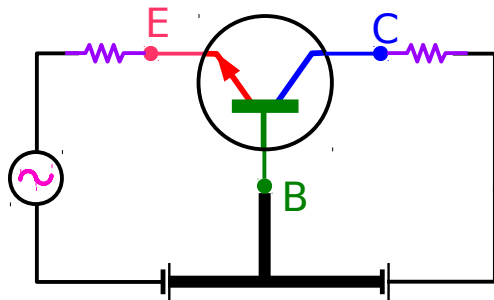

*Common Base*

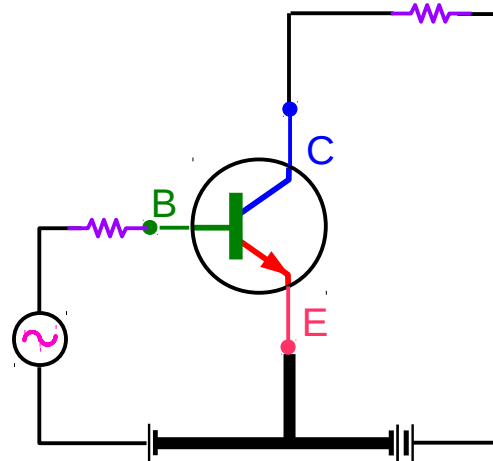

*Common Emitter*

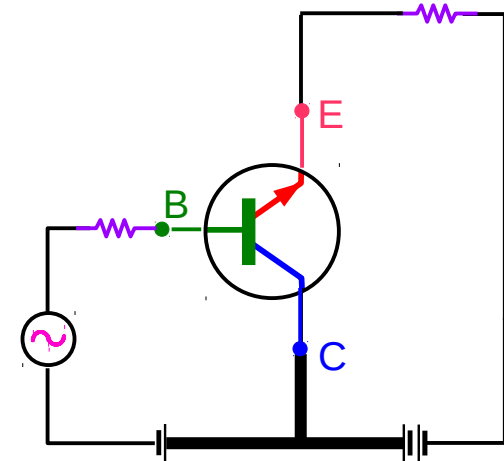

*Common Collector*

# AC Equivalent Circuits

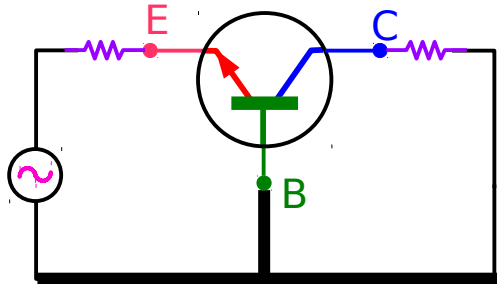

Common Base

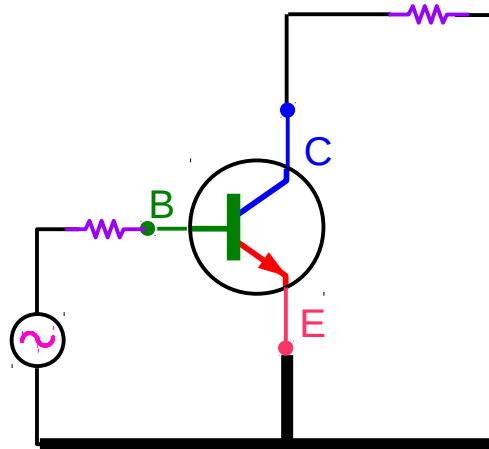

Common Emitter

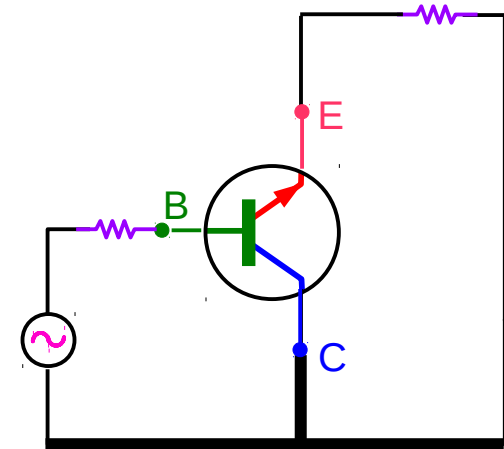

Common Collector

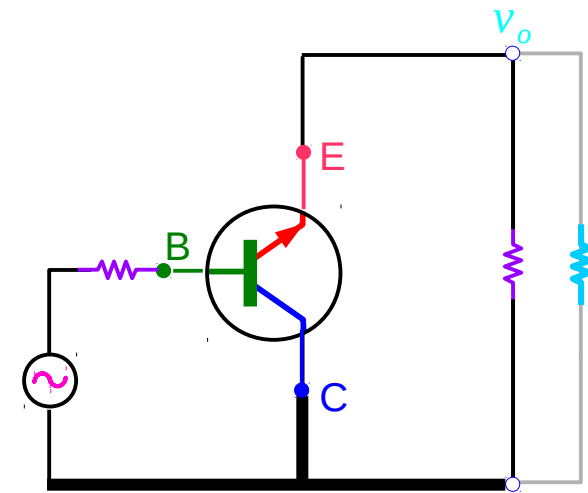
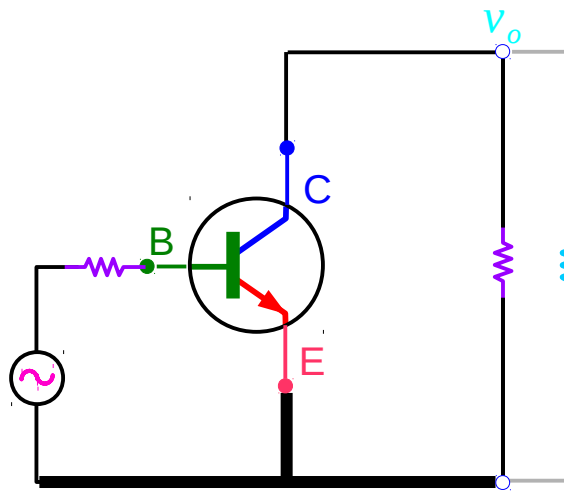
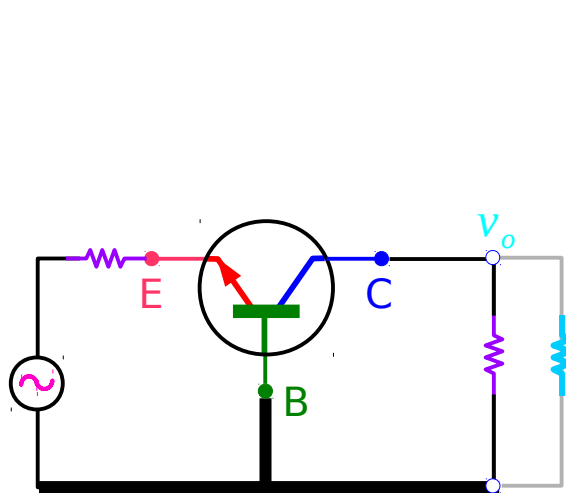

# AC Equivalent Circuits

---

# Common Base

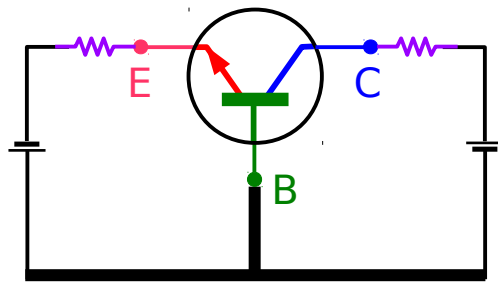

*DC Bias*

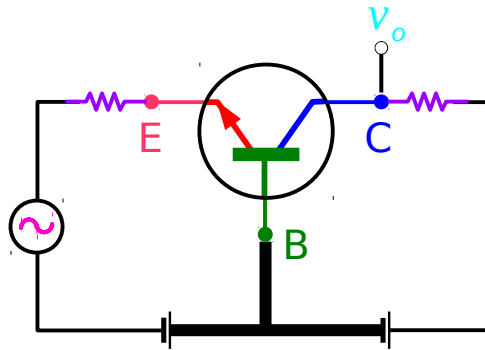

*DC Bias + AC Signal*

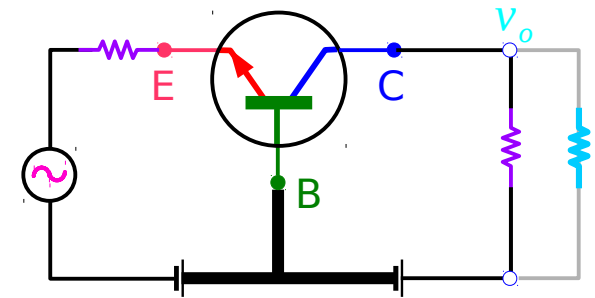

*DC Bias + AC Signal + Load*

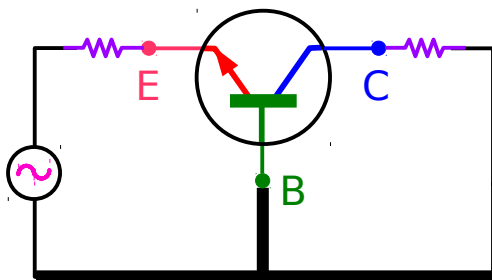

*AC Signal*

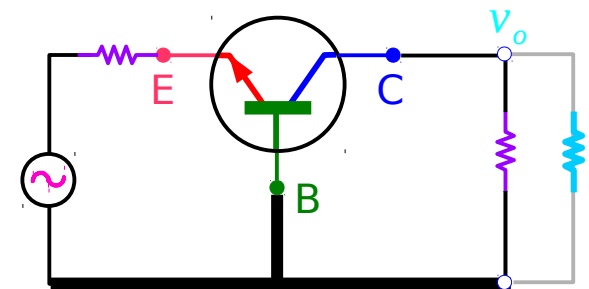

*AC Signal + Load*

# Common Emitter

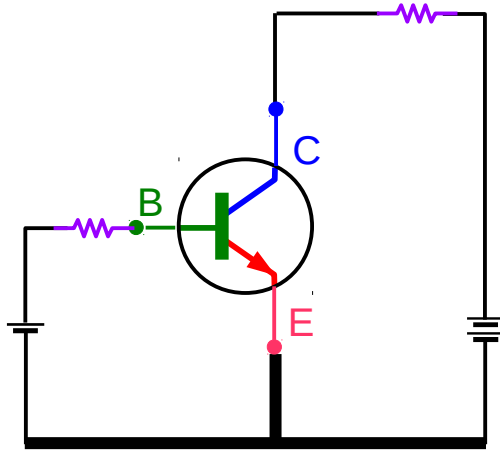

*DC Bias*

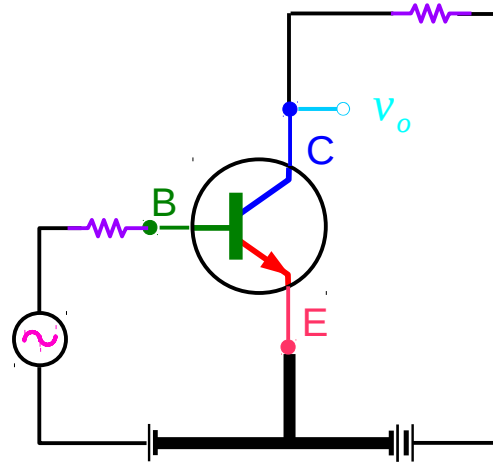

*DC Bias + AC Signal*

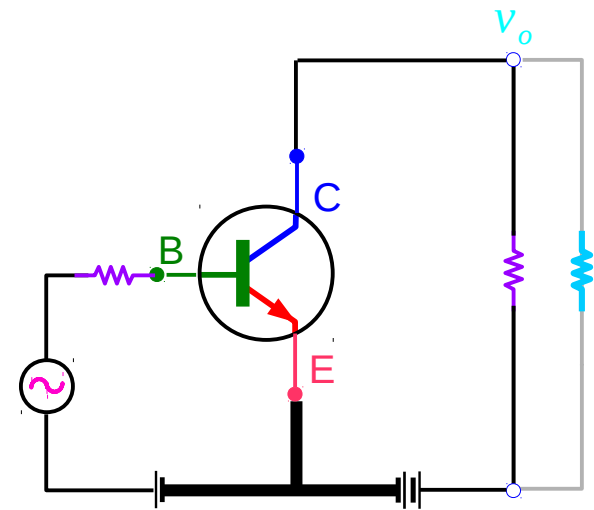

*DC Bias + AC Signal + Load*

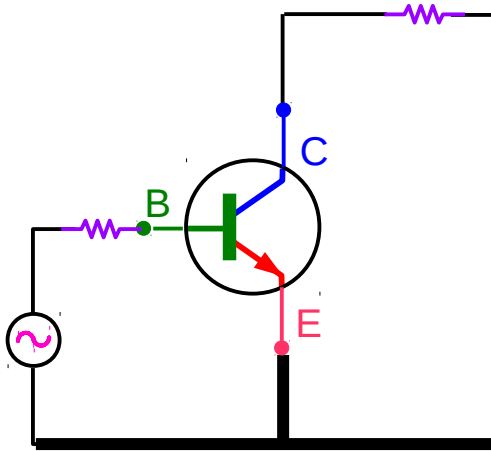

*AC Signal*

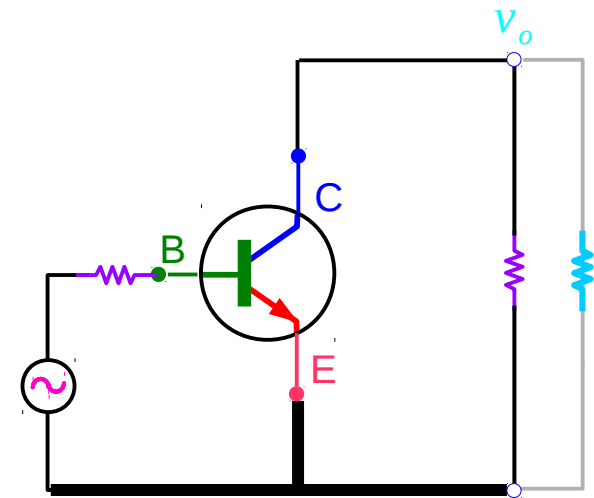

*AC Signal + Load*



# Common Collector

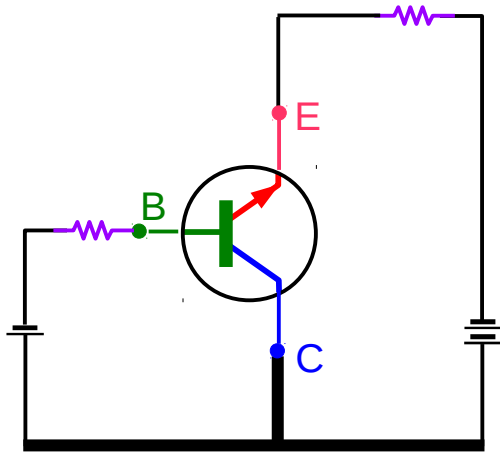

*DC Bias*

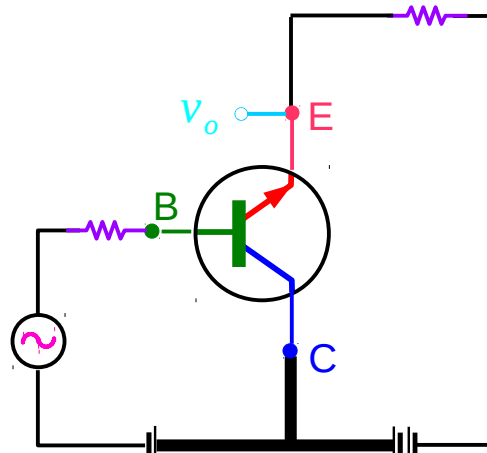

*DC Bias + AC Signal*

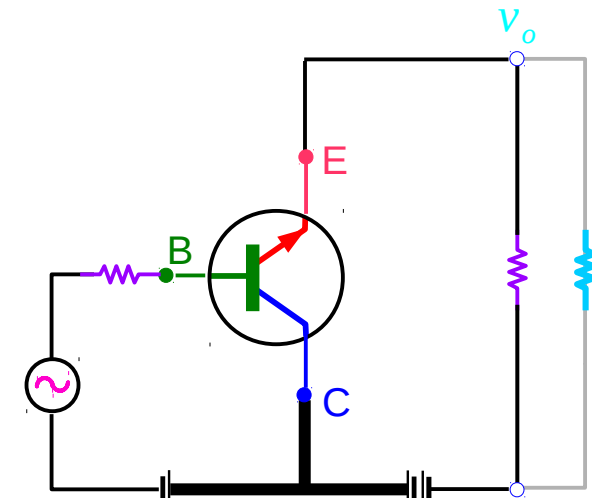

*DC Bias + AC Signal + Load*

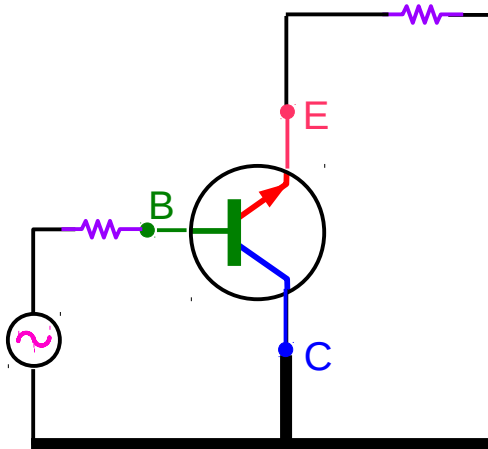

*AC Signal*

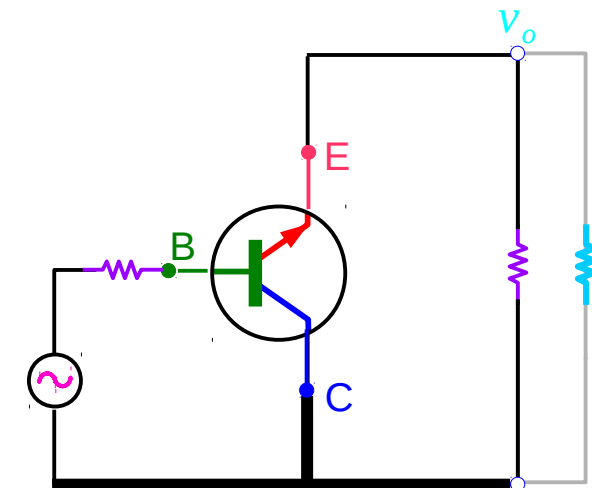

*AC Signal + Load*

# AC Equivalent Circuits

---

# AC t & pi models

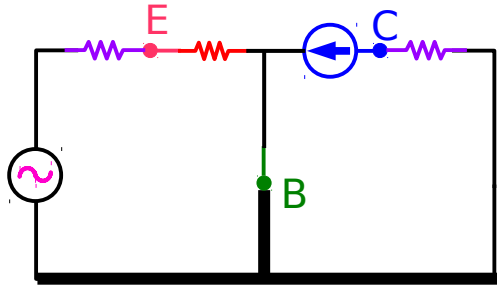

Common Base

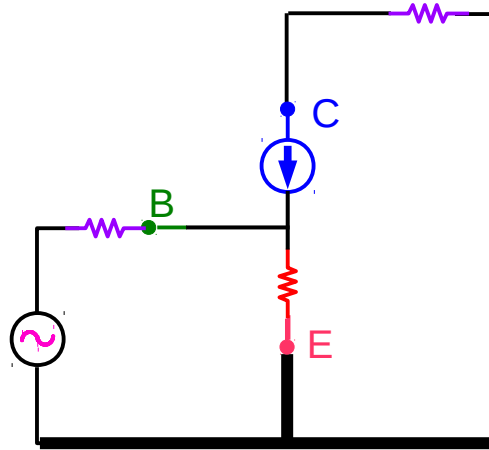

Common Emitter

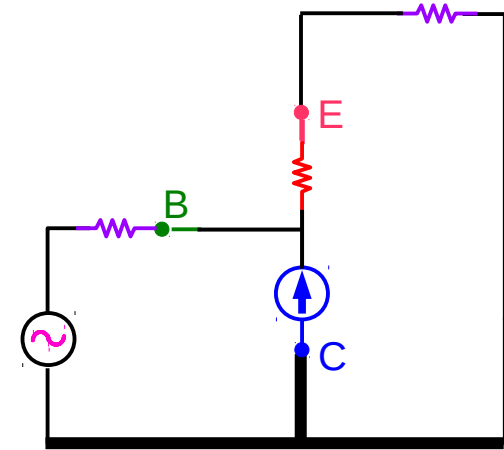

Common Collector

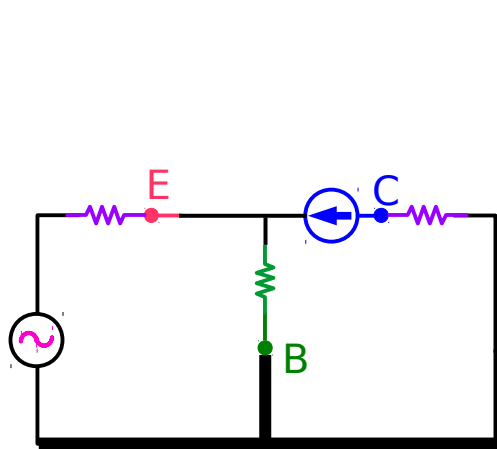

Common Base

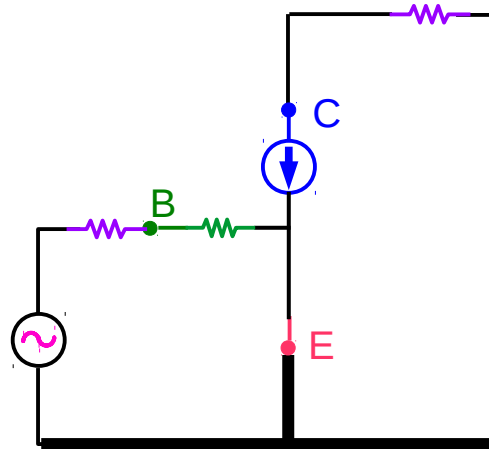

Common Emitter

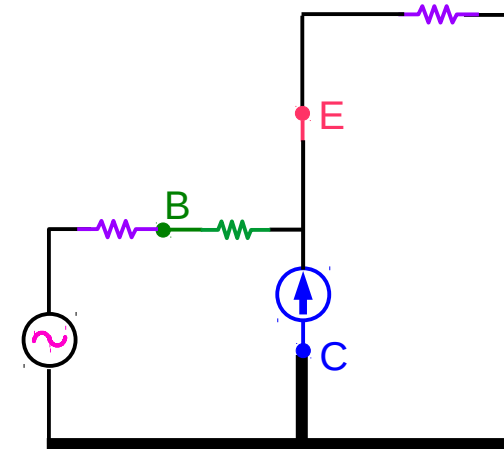

Common Collector

# AC Equivalent Circuits

---

# Storing Magnetic Energy

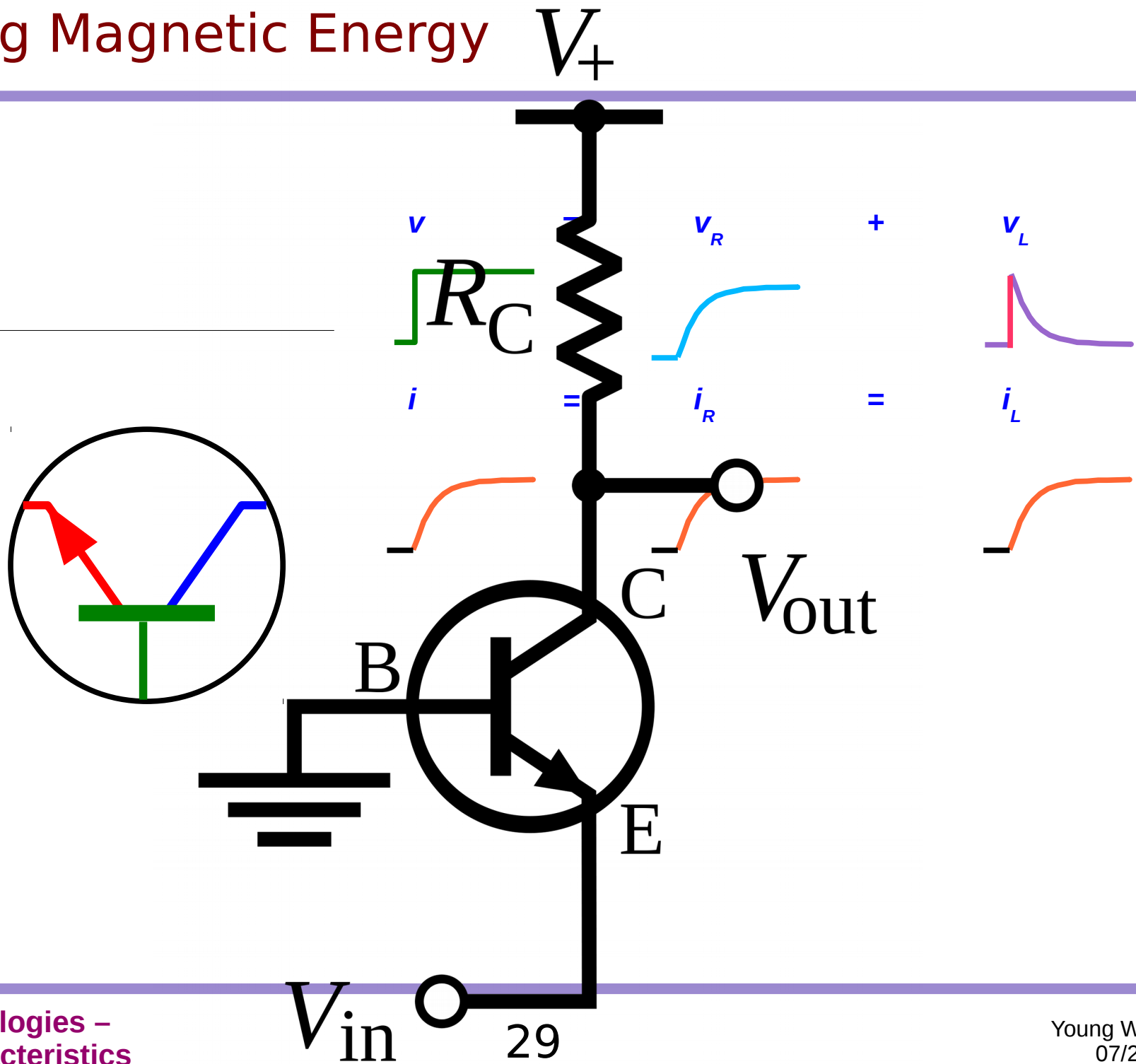

## References

[1] <http://en.wikipedia.org/>

[2] J.H. McClellan, et al., Signal Processing First, Pearson Prentice Hall, 2003